



American Bonanza Society Air Safety Foundation Landing Gear Inspection Checklist

For Beechcraft Bonanza, Debonair, Baron and Travel Air

For use in conjunction with manufacturer's guidance. See Amplification section for details on performing each inspection step.

1. Observe after flight that the inner main gear doors are fully closed with a little tension.
2. Check condition and inflation of tires.
3. Check main and nose gear struts for proper inflation and any signs of leaks.
4. Jack the aircraft
5. Check down tension on lift legs against shop manual figures for that model. Record the values.
6. Disconnect the main gear outboard doors.
7. Pull the LANDING GEAR MOTOR circuit breaker and turn the manual handcrank in the down direction (counterclockwise) to check the sector gear is not bottomed out.
8. Check squat switch(es) to insure they prevent retraction. Reconnect when done.
9. Crank the gear up part way, not over 20 turns of the handcrank.
10. Check for lift leg joint play.
11. Check the retract rod slip joints.
12. Check the inner gear door bushings.
13. Inspect the uplocks.
14. Check retract rods and rod ends.
15. Check the pivot bolts that attach the main landing gear struts to the spars.
16. Check for nose gear play.
17. Check the nose steering linkage.
18. Check the gearbox.
19. Lubricate the landing gear system.
20. Stow the manual handcrank, reset the gear motor circuit breaker and retract the landing gear the rest of the way electrically. **Let the gear motor cool several minutes.**
21. Extend the landing gear and time the gear extension.

American Bonanza Society Air Safety Foundation Landing Gear Inspection Checklist

22. Check uplock cable tension.
23. Retract the landing gear electrically. Check the uplock clearance and that the roller bearing is free to rotate.
24. Check that the main gear up stop bolt lightly contacts the main gear housing when the gear is up.
25. Check the up tension on the nose gear. Record the value.
26. Check the free play in the up side of the gear box.
27. Check the gear warning horn for function.
28. Fully extend the gear manually and listen for any unusual noises during the cycle.
29. Reconnect the outboard main gear doors.
30. Check the retractable cabin step and shear link (1947 Model 35—M35 only).
31. Lower the airplane from the jacks.
32. Check the brakes and brake lines.
33. Check the brake fluid reservoir for correct fluid level and leaks in the can.
34. Check the shimmy damper.
35. Check all three landing gear struts for proper extension length and strut leaks. Address any history of struts needing to be repeatedly serviced.
36. Check that the landing gear position switch is not loose.
37. Check the emergency hand crank placard between the front seats and all landing gear circuit breaker placards for legibility.
38. After the cabin inspection is complete, ensure the manual extension handle is stowed and it is not blocked by the spar cover. Install the protective boot or cover.

O'Halloran Aviation (beechparts@sbcglobal.net) has generously sponsored development of this ABS Air Safety Foundation mechanic training program.

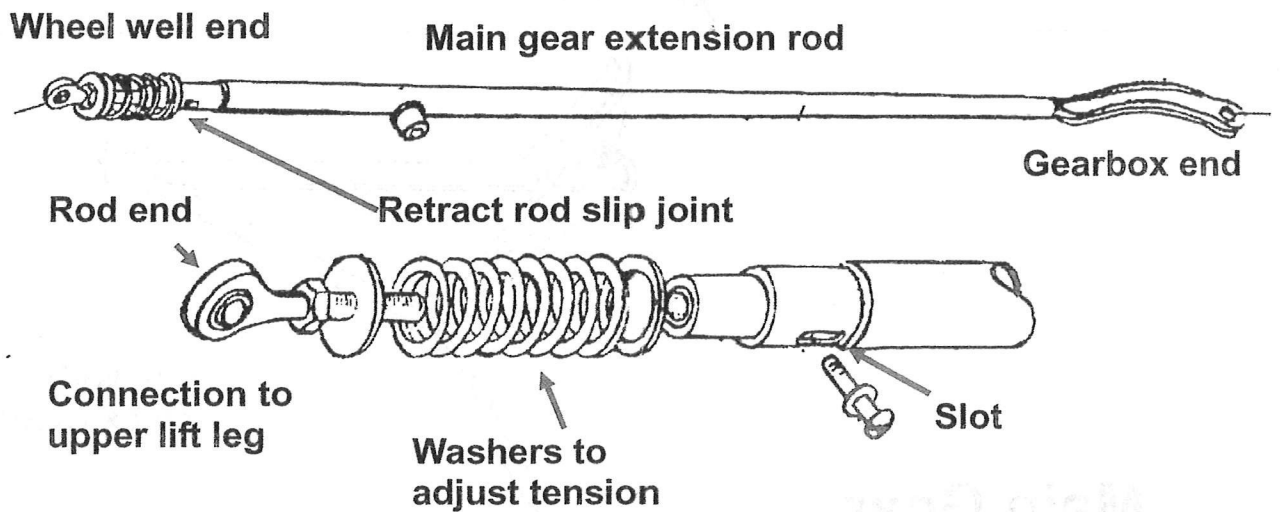
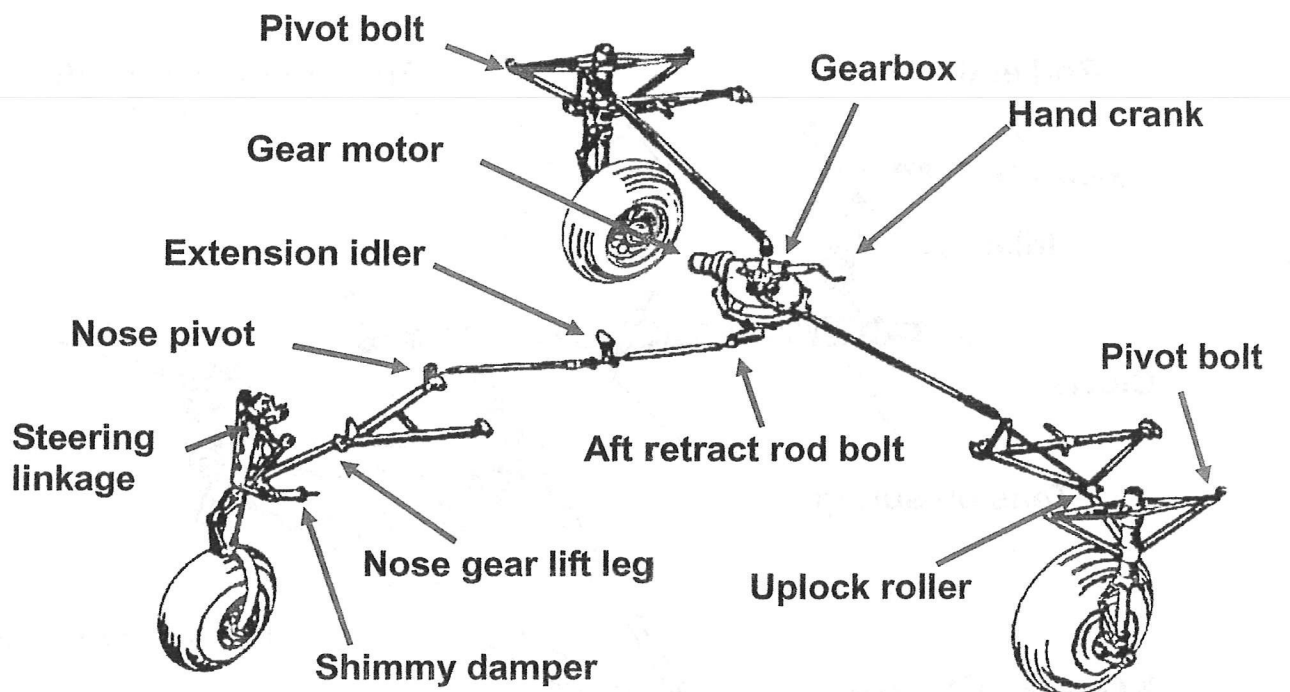

Parts of the Beech landing gear system

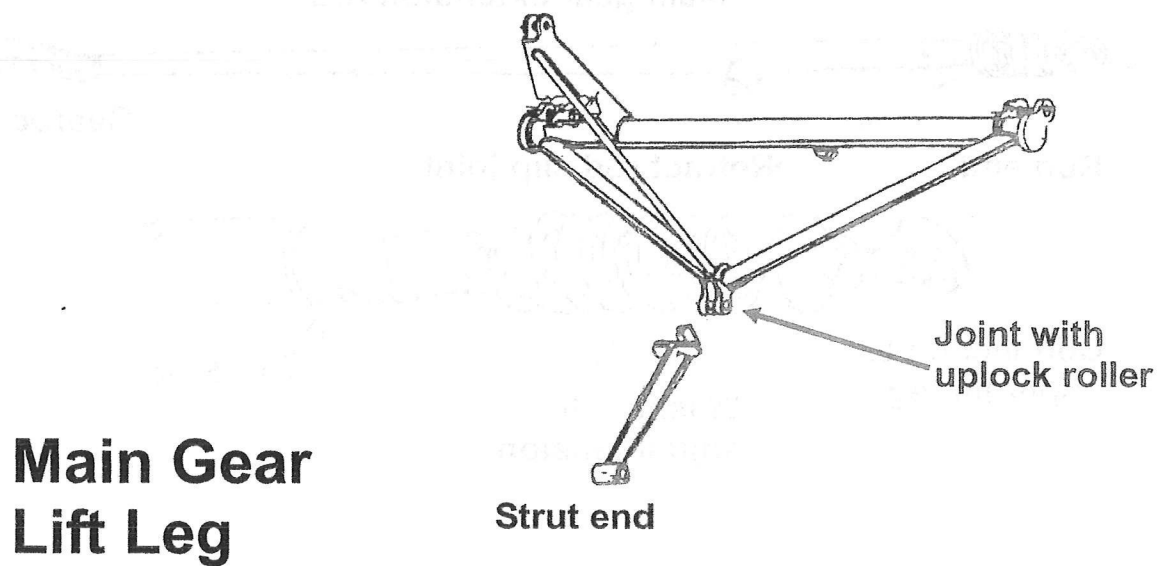
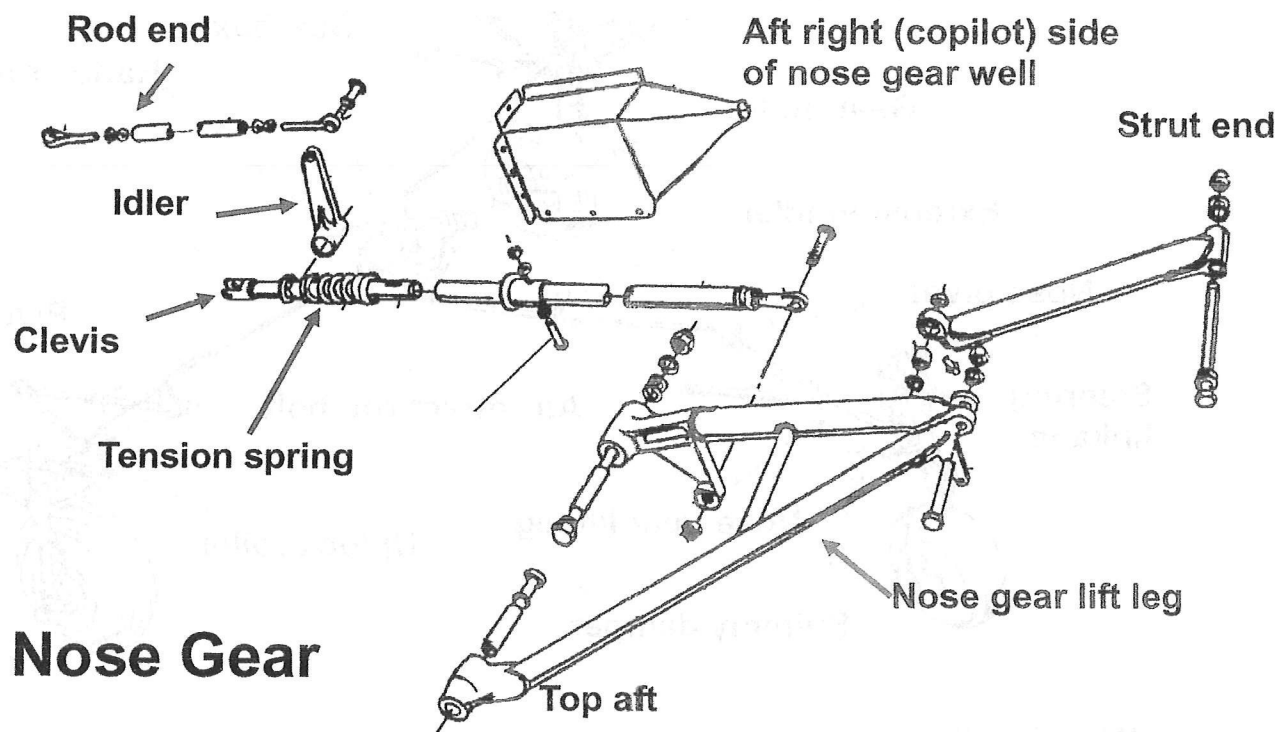

Parts of the Beech landing gear system



**American Bonanza Society
Air Safety Foundation**

Landing Gear Inspection Checklist

**For Beechcraft Bonanza, Debonair,
Baron and Travel Air**

Compiled and edited by Thomas P. Turner

Written and technical assistance by

Neil L. Pobanz, ABS lead technical advisor

Glen "Arky" Foulk

Richard H. Pedersen

Robert M. Olson

Arthur G. Miller

Robert G. Ripley

Robert E. Andrews

ABS Technical Committee

Arthur W. Brock, ABS president

Craig R. Bailey

Jon Luy

Ronald Lessley

Dr. Charles S. Davidson

Nancy F. Johnson, ABS executive director

©2008 American Bonanza Society Air Safety Foundation www.bonanza.org
All rights reserved

For educational purposes only. Refer to manufacturers data for all specifications. In the event of any contradiction the manufacturer's data takes precedence.

O'Halloran Aviation (beechparts@sbcglobal.net) has generously sponsored development of this ABS Air Safety Foundation mechanic training program.



Landing Gear Inspection Checklist Amplification

The quick-reference checklist is a result of decades of experience maintaining Beech piston aircraft, and thousands of airplanes inspected through the ABS Air Safety Foundation Service Clinic program. The checklist and amplifications are meant to serve as a supplement to Beechcraft publications, to fill in the gaps for mechanics not completely familiar with the Bonanza/Baron landing gear system. At all times if there is a discrepancy between this document and specific guidance in Beechcraft publications, the manufacturer's information takes precedence.

General

Properly inspecting the Beech landing gear system is a detailed process that goes far beyond a simple retraction test. Poorly rigged or worn landing gear systems are frequently found in Service Clinic inspections, and therefore likely common in the fleet. This may contribute to the high rate of landing gear failures in service.



Attempting to fix issues of damage or wear by adjusting or re-rigging the landing gear does not address the reasons behind the need for attention. Not only are the steps on the inspection checklist necessary to evaluate the condition of the landing gear, in many cases the *order* that checklist steps are done is important to get a proper indication or result. Accomplish the inspection in the order presented on the checklist to accurately determine the system's condition.

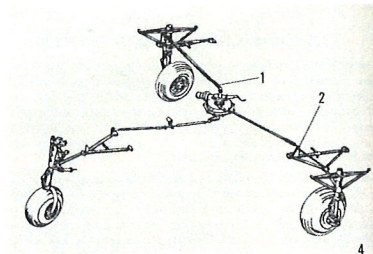

If rigging the landing gear, hook the airplane to external power to obtain full flight voltage (14 or 28 volts as applicable). If just inspecting the gear, fully charged aircraft battery power alone is sufficient.

Amplified inspection steps

- 1. Observe after flight the inner main gear doors are fully closed with a little tension.**



Main gear inner door in fully retracted position

Visually check the inner main gear doors as after the airplane arrives for inspection, in the condition it was in from the last flight. You're checking to see if the system works properly under normal operational conditions and air loads. If one or both inner gear doors hang open, even a little, there may be a problem with the electrical system or gear retract/extension motor that does not permit completion of the landing gear cycle. Or the gearbox's limit switches or dynamic brake may be out of rig, causing the gear motor to stop before the landing gear cycle is complete. Inner gear doors that are completely rigid against the bottom of the wings, however, may indicate the motor is not cutting off soon enough and the gearbox's sector gear is contacting the

internal stop when the gear cycles. This can cause cracking and failure of the gearbox's internal sector gear, preventing both electrical and manual gear extension. Note: the Beech nose gear doors are spring-loaded and will have lots of play when the gear is extended.

2. Check condition and inflation of tires.

Tire inflation values are found in the Handling, Servicing and Maintenance section of the Pilots Operating Handbook, and differ by model and year. Check for any sign of interference wear or rubbing on the tires, especially the nose tire on all types and the left main tire on Barons. Note: if changing size and/or manufacturer of tire, it's recommended you jack the airplane and perform a gear retraction test for interference before returning the aircraft to service. The Baron left main gear has a history of binding with flap cables if not properly inflated or if the flap cable is misrouted.

3. Check main and nose gear struts for proper inflation and any signs of leaks.

Strut inflation values are contained in the maintenance manual. Inspect for any leaks around the strut seals.

4. Jack the aircraft.

- A) Follow shop manual directions for jacking if using the Beech jack.

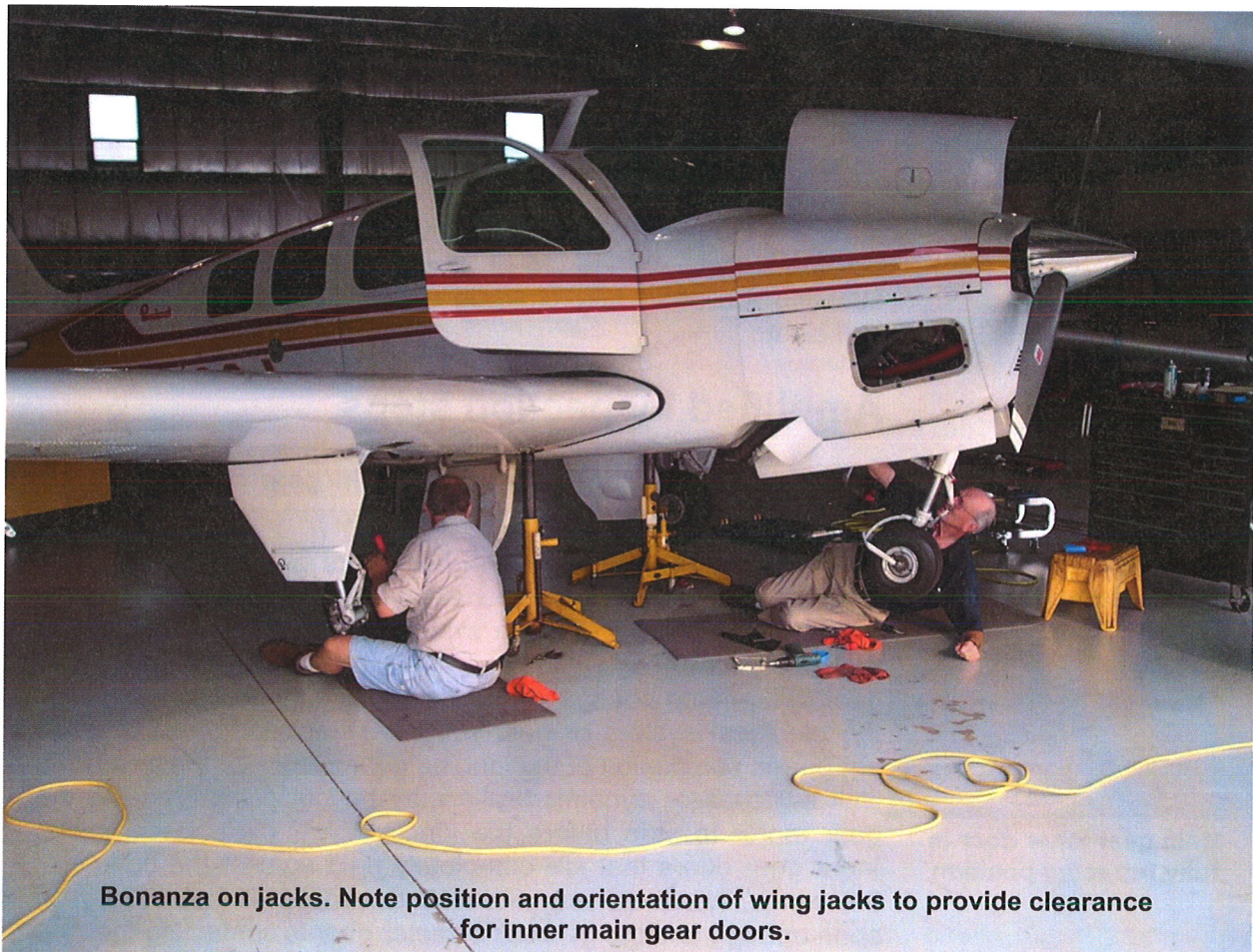

Bonanza on jacks. Note position and orientation of wing jacks to provide clearance for inner main gear doors.

B) If using free-standing jacks with a tail stand:

- i) Use at least 400 pounds on the tail stand.
- ii) When positioning underwing jacks, orient the jacks to provide clearance for the inboard gear doors.
- iii) Jack the mains slightly until the tail has raised enough to attach the tail stand. The tail may be a little high once the tail stand is attached.
- iv) Continue jacking the mains until the airplane is level or slightly tail low. It only takes an inch or so ground clearance beneath the main wheels when gear struts are extended. Note if tail is too low this may allow the inboard doors to contact one or more of the jacks. If unsure of door to jack clearance on the first retraction bump the gear up electrically while someone visually checks the clearance. **Do not retract landing gear until after the down lock tension check (step 5) and squat switch(es) check (step 8) have been completed.**
- v) Ensure there is adequate clearance between the nose gear and the floor before retraction.

5. Check down tension on lift legs against shop manual figures for that model. Record the values.

Using a calibrated mechanical or digital push-pull force gauge, push on the knee joint of the lift leg and check the force required to deflect the joint. Record the results of all three landing gear and compare them to the tolerances listed by model in the maintenance manual. Note: keep push-pull force gauge approx. 90 degrees to lift leg when performing this check. On twin-engine aircraft equipped with the positive downlock mechanism, this system must be disconnected in order to perform a main gear down lock tension check.

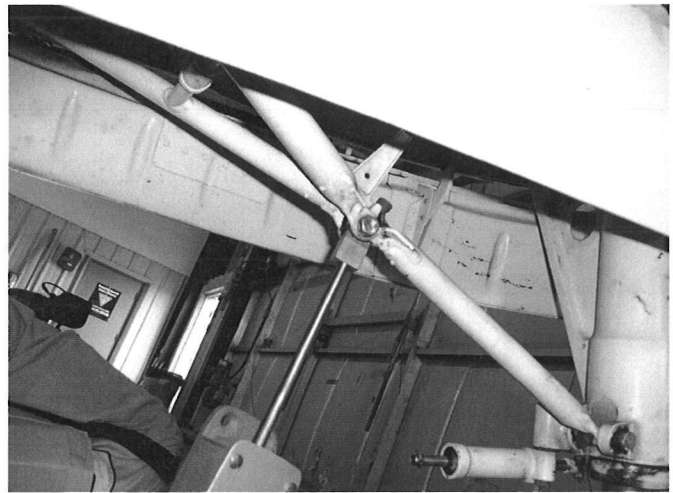

Checking the nose gear down tension with a mechanical push-pull force gauge.

Checking downlock tension on the main landing gear.





Chatillon Model 80D mechanical push-pull force gauge. This commonly used gauge is no longer in production.



Shimpo FGE-100 digital push-pull force gauge. Note there are several models of push-pull force gauges that can be used.

6. Disconnect the main gear outboard doors .

Disconnect the two links at the clamps around the main gear strut. It is a good practice to leave the bolts in the same holes in the clamp and install washers and nuts so they are not lost and there is no confusion as to which hole the bolts were in. The correct orientation of the bolts is head to head.

Leave the outboard gear door hanging loosely to provide access for the inspection.

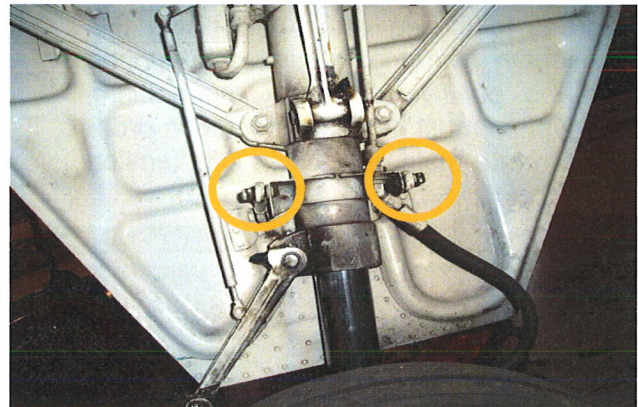

Outer gear door disconnect points

7. Pull the LANDING GEAR MOTOR circuit breaker and use the manual handcrank in the down direction (counterclockwise) to check the sector gear is not bottomed out.

Pull the LANDING GEAR MOTOR circuit breaker.

Turn the manual handcrank in the down direction (counterclockwise) to check that the sector gear is not bottomed out.

There should be 1/8 to 1/4 turn counterclockwise remaining to the stop when you crank the emergency handcrank down, except for the following serial numbers that should have 5/8 to 3/4 turn remaining:

V35B D-10375 and after

F33A CE-968 and after

A36 E-1876 and after

B36TC EA-239 and after

Baron 55 TC-2414, TE-1195 and after

Baron 58 TH-1269, TK-147, TJ-384 and after

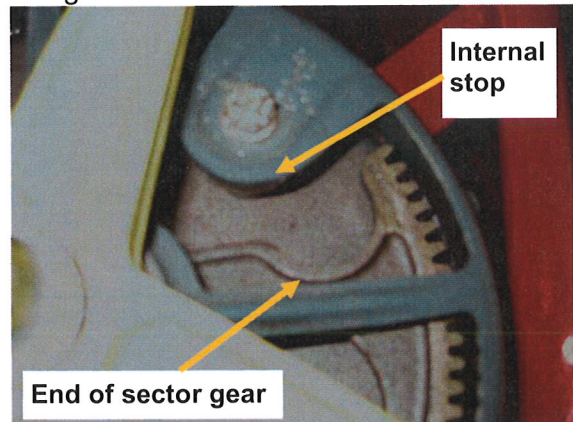

Cutaway of a gearbox showing the sector gear approximately six turns of the hand crank from the end of cycle, but not contacting the internal stop.

If the handcrank has less than these turns remaining with the gear down under normal circumstances, the dynamic brake may not be stopping the gear motor in time to prevent the gear box from contacting an internal stop at the end of the extension cycle. This in turn can cause the gearbox's sector gear to bend, crack or fail. If the handcrank turns too far in this condition, the gear motor and/or dynamic brake may be stopping the gear before it is fully locked down. This risks a gear collapse. This condition may also be indicated by an inner main gear door or doors that do not fully close. **STOW THE HANDCRANK.**

Note: If the sector gear hits the stop in either the extended or retracted position, the gearbox and motor should be removed and overhauled. The most common cause of this condition is a gear motor that is overdue for overhaul. If the motor's brushes are worn, springs are weak or the commutator is dirty or worn the motor will not stop instantly and will drive the sector gear into the stop. Do not attempt to replace motor brushes in the field. Brushes need to be run in for good brush contact with the commutator and provide proper dynamic brake operation. Send gear motors to a qualified shop for overhaul.

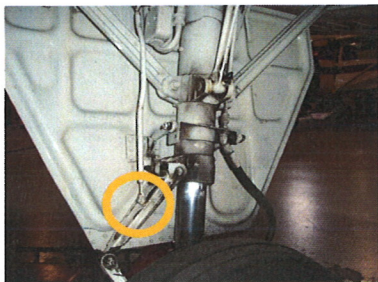

Squat switch disconnect point

8. Check squat switch(es) to insure they prevent retraction.

Disconnect the squat switch(es) one at a time. Reset the landing gear motor circuit breaker.

(Single squat switch): Move the landing gear switch to the UP position. Turn the master switch ON momentarily. Gear should not retract and the gear warning horn should sound. NOTE: very early aircraft do not have a warning horn.

(Dual squat switches): Check one switch at a time. NOTE: starting in about 1970 the horn will activate off a single switch.

Reconnect the squat switch linkage(s).

9. Crank the gear up part way, not over 20 turns of the handcrank.

Pull the landing gear motor circuit breaker and manually retract the landing gear no more than halfway, 20 turns of the crank clockwise. *Note:* Retracting the landing gear fully using the manual handcrank may damage the tangs on the worm gear shaft.

Do not manually retract the landing gear more than 20 turns.

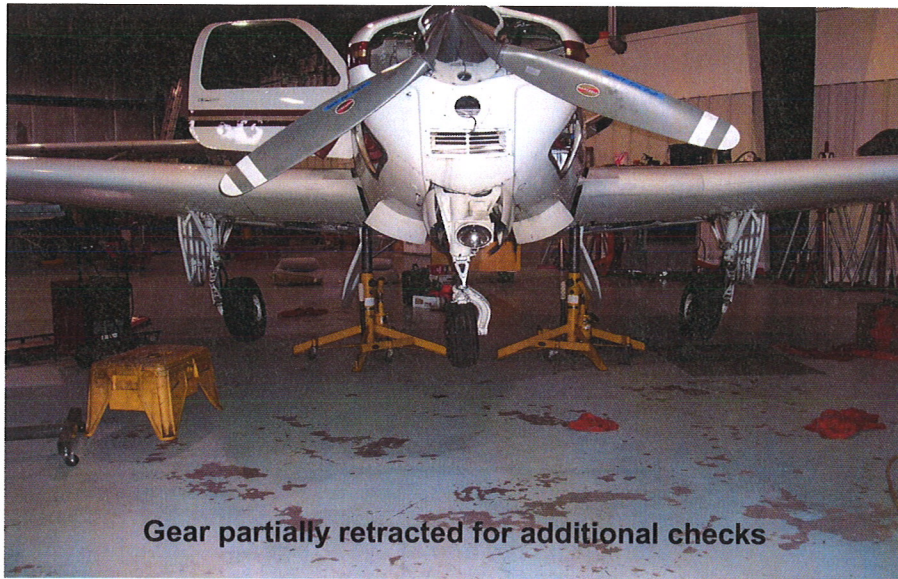

10. Check for lift leg joint play.

With the gear at mid-extension, check each wheel for play by grasping each tire and wiggling it. It's okay to feel some play, but you should not be able to see any.

Check that the bolt attaching the drag brace to the strut cannot be turned using fingers.

11. Check the retract rod slip joints.

While pulling the main wheels toward the fuselage, check that the retract rod slip joint springs compress.

Retract rod slip joints

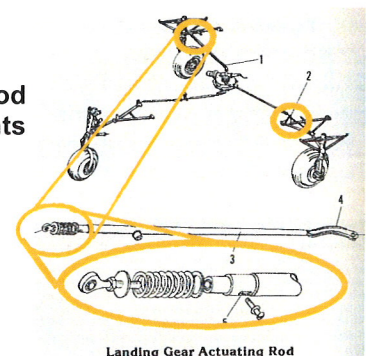

12. Check the inner gear door bushings.

Wiggle each inner main gear door. There should be no movement of the attach hinges or bushings.

13. Inspect the uplocks.

Check the uplock cable for the Tygon tube. Note: Addition of Tygon tube on earlier airplanes is called out in Beechcraft Service Instructions No. 0448-211, Rev. 1 and FAA Airworthiness Directive 2007-08-08. This AD supersedes AD 72-22-01, which may be referenced in the airplane's logs.

Check the uplock cable for fraying at the swagged end.

Check the uplock springs for corrosion.

Check the holes in the uplock bracket and the spring attach holes are not elongated or corroded.

Cable and Tygon tube

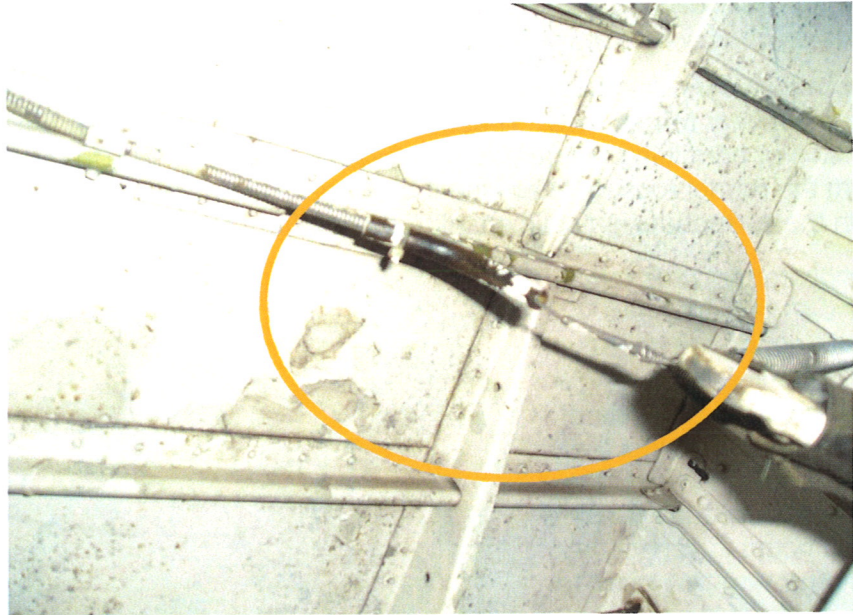

Canvas boot

Uplock springs

Note: The protective canvas boot has been removed from the uplock for the inspection

Attach holes

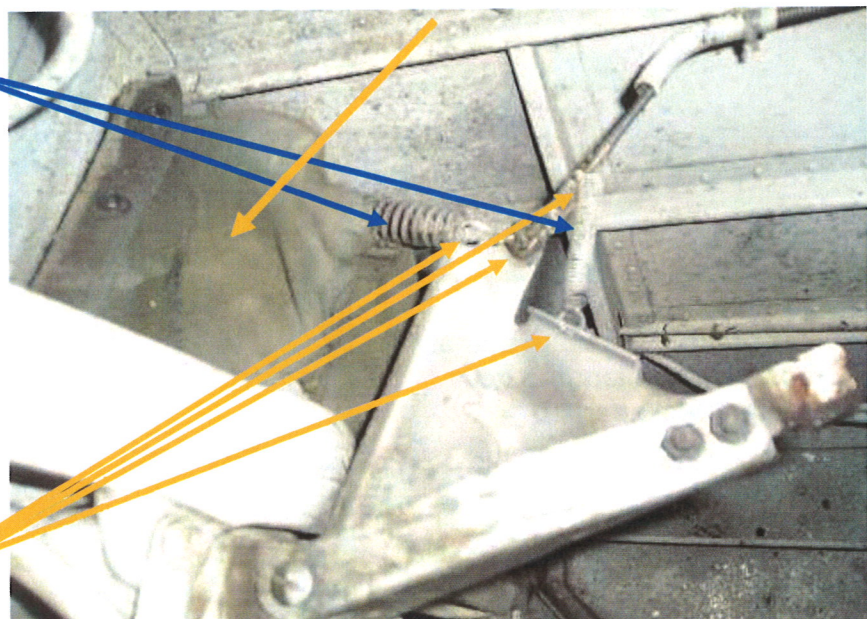

14. Check retract rods and rod ends.

Check retract rods and rod ends for corrosion, bends, play and freedom to rotate.

Look for evidence of distress in the connection (includes under the boot in the aft nose well).

Check that the rod ends at the outboard main gear doors are free to rotate.

Check the bolt at the inboard gear door retract rod at the forward hinge and the outboard uplock cable bolt for proper installation, with bolt heads pointed aft.

Worn and failed rod ends are commonly found as possible contributors to gear collapse and mechanically caused gear up landings. ABS recommends preemptive replacement of all rod ends on condition or at 2000 hours in service, whichever comes first.

For many years Beechcraft used hollow shank rod ends, three on the nose gear and two on the main gear retract rods. These have a history of bending or breaking, preventing gear extension or permitting the gear to collapse after landing. These rod ends should be removed from the retract rods to determine if they are of the hollow type. If so, consider replacing them with the current-design solid shank rod ends from Hawker Beechcraft.

Hollow retract rods can corrode internally and break during the gear cycle, jamming or causing a gear collapse on landing. Remove and inspect the retract rods (three for the nose, two for the mains) at 1000 hours in service. Apply corrosion treatment to the inside of the rods before reinstallation.

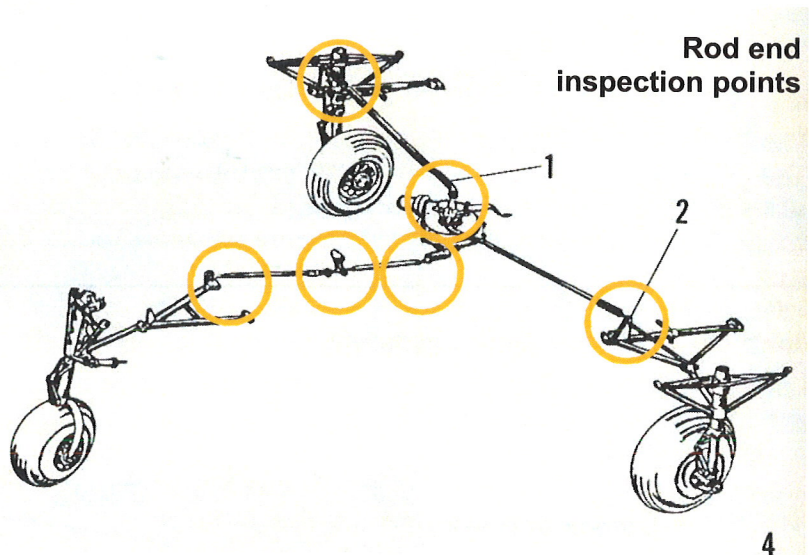
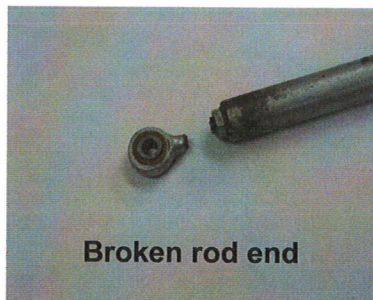

15. Check the pivot bolts that attach the main landing gear struts to the spars.

Use a wrench to check that the bolts do not rotate.

The strut should rotate on the bushing without bolt movement.

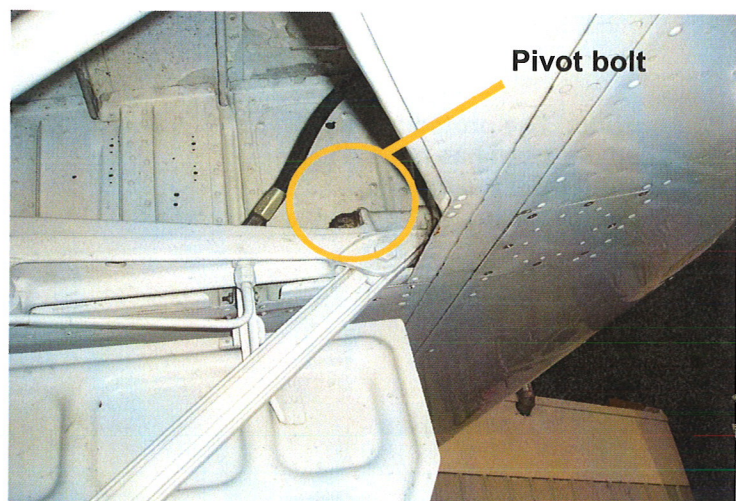

16. Check for nose gear play.

Grasp the nose wheel. Wiggle it and check the wheel for play. It's okay to feel some play, but you should not be able to see any movement in the strut.

Use a wrench to check the nose gear lift leg attach bolt for looseness.

Push on the nose gear. If the main gear moves much when you push aft on the nose gear, there is too much end play in the worm gear in the gearbox. Nose gear door movement is normal.

Check the nose gear retract rod at the underside of the gearbox. While pulling the nose strut aft slightly to unload the nose gear, you should not be able to turn the bolt with a screwdriver. The bolt should be installed so the head of the bolt is down. Check for excessive wear between the nose gear actuator arm and the splines. Check for gearbox oil leaks.

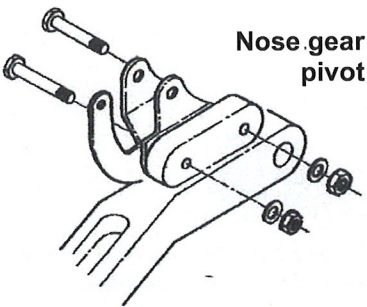

Nose gear pivot

On aircraft with the aluminum forging lift leg, check the right side of the nose gear pivot for movement where the inboard and outboard arms are bolted to the forging. Place a finger on top of the lift leg and press against the inboard arm while moving the nose gear slightly fore and aft. There should be no movement between these parts. Any movement here will cut down on nose gear tension.

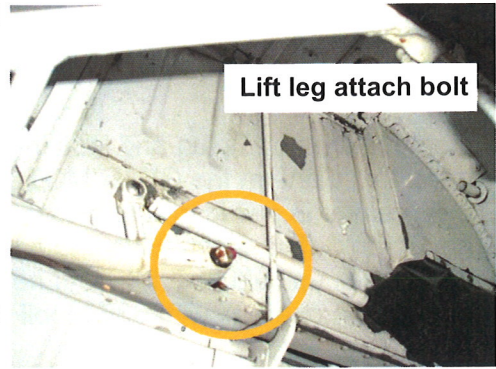

Lift leg attach bolt

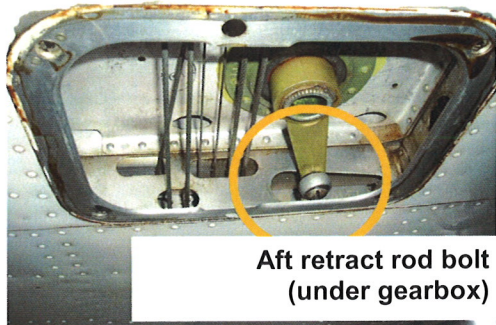

**Aft retract rod bolt
(under gearbox)**

17. Check the nose steering linkage.

Check the nose gear steering linkage for security and any damage.

There is a roller bearing in the nosewheel centering mechanism on the upper, aft side of the strut. Check that this bearing is able to rotate.

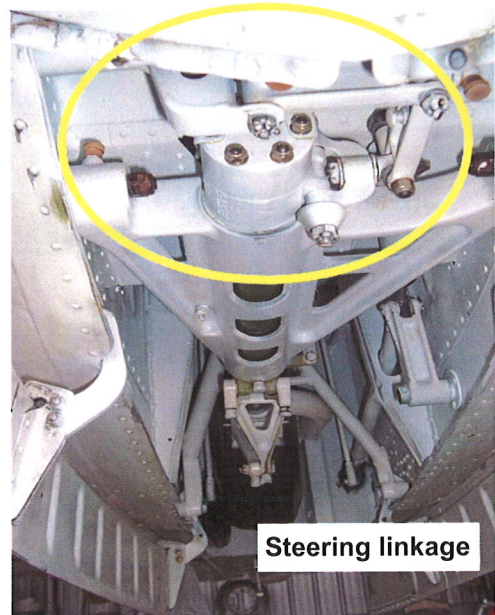

Steering linkage

18. Check the gearbox.

Make sure the gearbox is securely attached to the airframe.

Check the fluid level.

Remove the head plug and look into the gearbox. Confirm the GEAR MOTOR circuit breaker is pulled and turn the manual handcrank. The worm drive should just barely pick up fluid as it turns. If needed, service the gearbox with 636 Mobil or Mobil 1 oil.

A common indication of an over-serviced gearbox is leaking fluid on the cabin interior below the landing gear emergency handcrank.

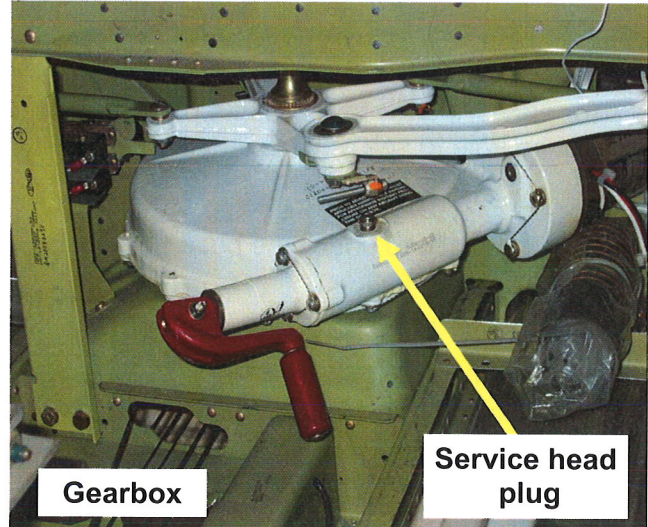

It takes only eight ounces of fluid to fully service a completely empty gearbox.

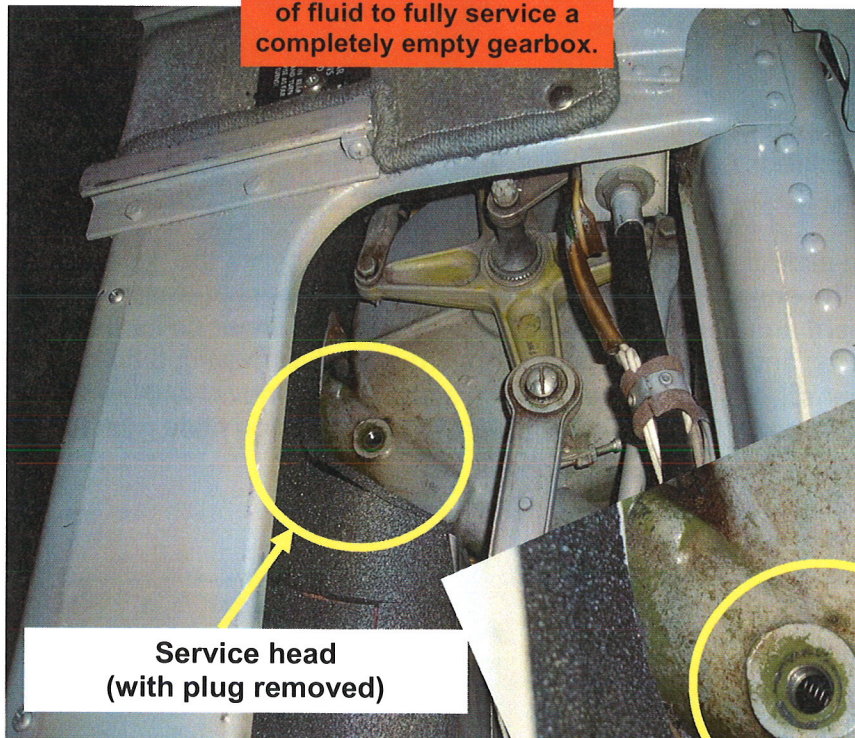

Looking down at the gearbox, beneath the copilot seat

Close-up of the service head. The worm gear is visible through the opened head.

Service head (with plug removed)

Alternate method to check fluid level:

- Insert a white tie wrap in the hole beside the worm gear as a dipstick.
- There should be approximately 1/4 inch of fluid in the gearbox.
- Ensure the worm gear picks up fluid as it turns.

19. Lubricate the landing gear system.

Lubricate the landing gear system as directed by the Beechcraft maintenance manual and/or the airplane's Pilots Operating Handbook.

20. Stow the manual handcrank, reset the gear motor circuit breaker and retract the landing gear the rest of the way electrically.

Let the gear motor cool several minutes before the next extension .

21. Extend the landing gear.

Time the extension.

14 volt airplanes should run in 9-11 seconds.

28 volt airplanes should run in 4-5 seconds.

Slow gear cycle time on proper system voltage may be an indication of a weak landing gear motor. It may indicate the need for a landing gear motor overhaul or replacement.

Slow gear transit could also be a symptom of binding or a high-resistance electrical connection somewhere in the aircraft.

22. Retract the landing gear electrically.

Check the uplock clearance on the mains.

There should be 0.010 to 0.020 inch clearance between the uplock arm and roller bearing when retracted.

Check that the roller bearing is free to rotate.

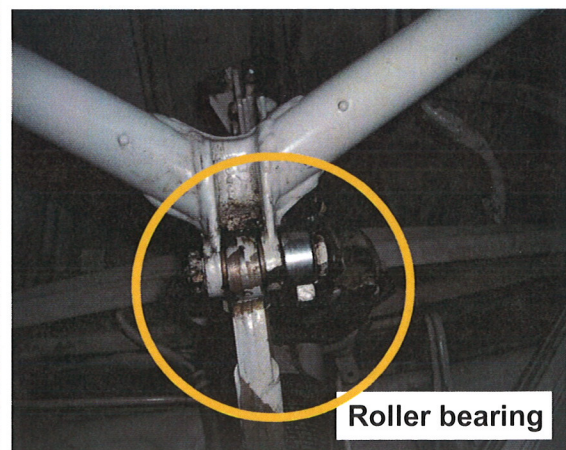
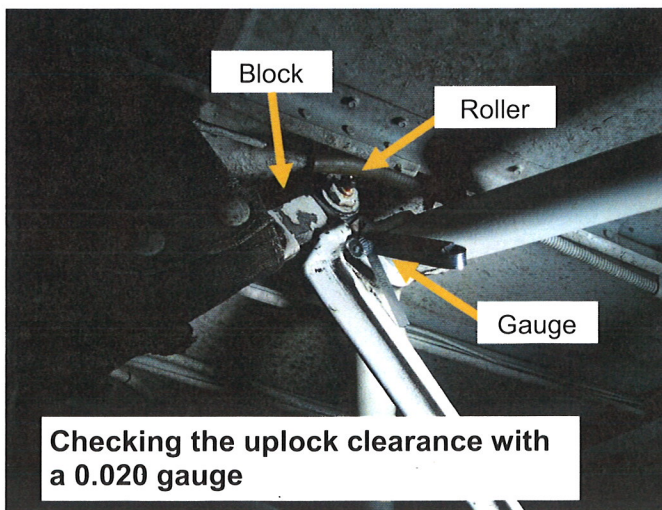

23. Check uplock cable tension

With an instrument calibrated for 1/16 inch cables, tension should be 52 ½ pounds, +10/-0.

24. Check the main gear up stop bolt.

The bolt should lightly contact the main gear housing when the gear is up.

25. Check the up tension on the nose gear.

Tie a long piece of safety wire around the area of the steering pins on the nose gear. Have a person raise the gear while holding the wire so it goes between the gear doors. You can then use the wire with a tension meter to check up tension.

26. Check the free play in the up side of the gear box.

Pull the LANDING GEAR MOTOR circuit breaker.

Turn the manual handcrank in the up direction (clockwise) to check the sector gear is not against the up stop.

There should be 1/8 to 1/4 turn clockwise remaining to the stop when you crank the emergency handcrank down, except for the following serial numbers that should have 5/8 to 3/4 turn remaining:

- V35B D-10375 and after
- F33A CE-968 and after
- A36 E-1876 and after
- B36TC EA-239 and after
- Baron 55 TC-2414, TE-1195 and after
- Baron 58 TH-1269, TK-147, TJ-384 and after

Gearboxes originally painted green should have 1/8 to 1/4 turn tolerance and gearboxes originally painted white should have 5/8 to 3/4 turn remaining at the end of electric travel. Many airplanes have been retrofitted with earlier or later gearboxes, and many originally green gearboxes have been erroneously painted white when overhauled.

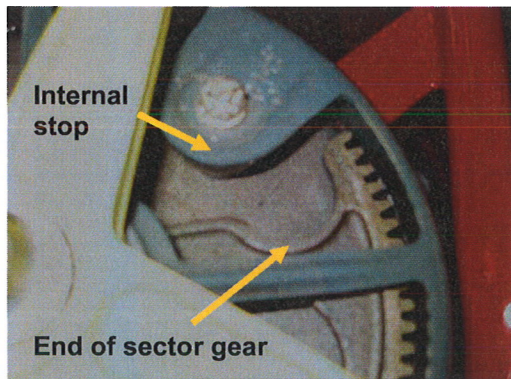

Sector gear near but not contacting the internal stop.

Some gearboxes may have been painted other colors when new or overhauled.

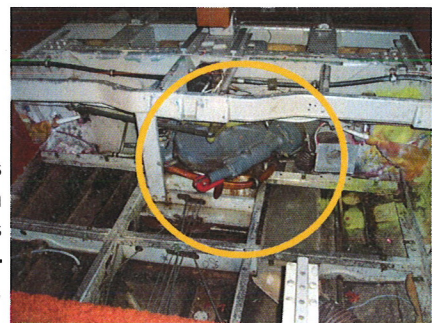

If the handcrank has less than this turn remaining with the gear up under normal circumstances, the dynamic brake may not be stopping the gear motor in time to prevent the gearbox from contacting an internal stop at the end of the retraction cycle. This in turn can cause the sector gear to crack and fail. If the handcrank turns too much in this condition, the gear motor and/or dynamic brake may be stopping the gear before it is fully up. This may allow flight loads to damage the gear pushrods. **Note:** The dynamic brake can also be checked in flight by the pilot using this procedure.

27. Check the gear warning horn for function.

With electrical power applied, reduce the throttle to idle and note the landing gear warning horn is audible.

Check each throttle individually in Barons and Travel Airs.

Early aircraft have a single circuit breaker that controls both the gear motor and the gear warning and indicating systems. In these airplanes, reset the circuit breaker before testing the gear warning horn.

28. Extend the gear manually and listen for any unusual noises during cycle.

Investigate any unusual noises or indications.

29. Reconnect the outboard main doors.

Check the proper fit of the gear doors.

Check the outboard gear door link rod ends to make sure they rotate.

Cycle the gear to ensure doors properly function.

Do not run the gear multiple times without cooling time, to prevent motor overheating.

To reconnect the outer door the hardware sequence is: Both fore and aft bolt heads face the strut. The forward connection is bolt through the bracket, two washers, the link rod end, one washer and the nut. The aft connection is the bolt through the bracket, one washer, the link rod end, one washer and the nut.

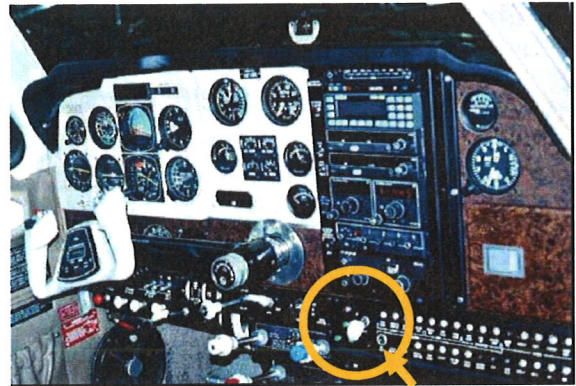

Gear selector and circuit breaker

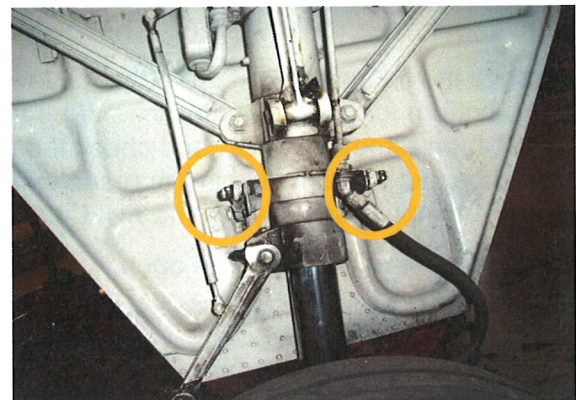

Outer gear door connection points

30. Check the retractable cabin step.

This applies only to the 1947 Model 35 thru M35, serial number D-1 through D-6561.

As the gear cycles (Step 24), check for:

Binding in operation.

Frayed cables.

A sticking step.

Unusually slow gear extension cycle (that might indicate cable resistance).

Check that the shear link is installed and is intact.

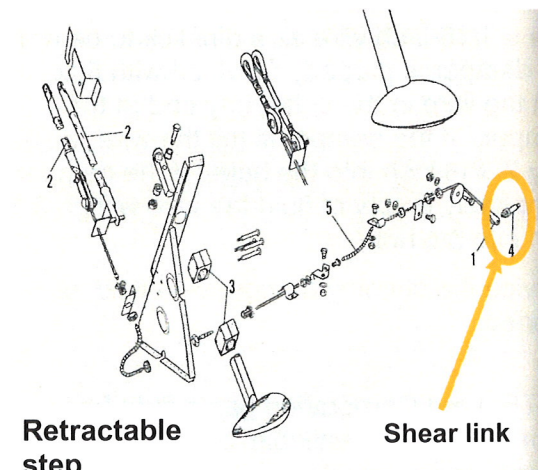

Retractable step

Shear link

31. Check the brakes.

Check brake lines for leaks and chafing.

Check brakes discs for wear or warping. Check that the discs are secure and are of at least minimum thickness.

Check brake pucks/pads for wear and replace as necessary.

Cleveland brakes manuals specific a minimum disc and brake puck thickness.

Goodyear brakes (now owned by American Braking Systems) data do not provide any minimum thickness guidelines.

Check Goodyear brake clips for condition and replace as necessary.

32. Lower the airplane from the jacks.

Check all gear down indications. Remove any obstructions from beneath the airplane before lowering. Keep the airplane level as it settles back onto the floor.

33. Check the brake fluid reservoir for correct fluid level and leaks in the can.

The brake fluid reservoir is located in the left side of the engine compartment, mounted high on the firewall on Bonanzas and Debonairs, and on the left side of the nose baggage compartment in Barons and Travel Airs. The reservoir has a screw-on lid.

Remove the lid and look at the attached level indicator, which may either be a tube with a disc at the bottom, or a straight dipstick. Wipe the indicator dry, reinsert it in the can and screw on the lid, then remove it again and check the fresh indication. On the disc-type indicator there should be just enough fluid in the reservoir to puddle on the disc. With the dipstick type the fluid level should be between the FULL and ADD lines.

Verify that the canister vent is open.

Add fluid as needed. Some owners may wish to change the brake fluid annually.

34. Check the shimmy damper.

The shimmy damper should have no play, and show no sign of leaks.

Use a 1/16-inch wire as a dipstick to determine the damper is properly serviced with fluid. Insert the wire in the cotter key end of the damper. If the damper is full the wire will go only 2 3/16 inch into the hole. If the damper is completely empty of fluid the wire will go 3 1/16 inch into the hole.

Service the shimmy damper with fluid as needed.

NOTE: Lord Corporation has a fluid-free shimmy damper available for installation on all models under an STC.

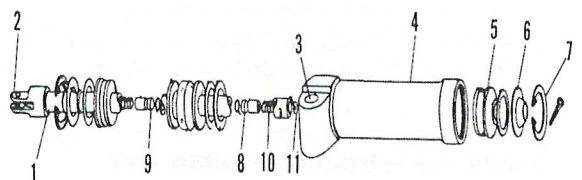

Shimmy damper

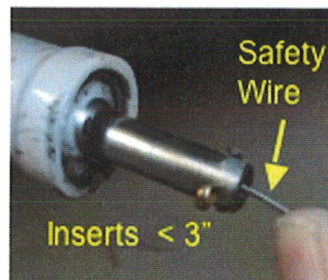

Checking the fluid level

35. Check all three landing gear struts for:

Proper extension length (varies by model; see Maintenance Manual or POH).

No sign of strut leaks.

No history of needing to be repeatedly serviced.

36. Check that the landing gear position switch is not loose (Airplanes with white, wheel-shaped gear position switch).

The landing gear position switch is screwed on and held in place with a set screw. If the handle is screwed on too far it pulls away from the panel and will move up or down without being pulled over the detent.

37. Check the emergency hand crank placard between the front seats and all landing gear circuit breaker placards for legibility.

Placard

Improperly installed spar cover and obstructed handcrank



38. After the cabin inspection is complete, ensure the manual extension handle is stowed and it is not blocked by the spar cover. Install the protective boot or cover.

It is quite common that mechanics install the forward spar cover (in later models) so that the hard plastic covers the stowed landing gear emergency handcrank. The plastic is very hard and tolerances in this condition very tight. It is not possible to unstow the handcrank in this condition, so it would prevent a manual landing gear extension in the event the gear could not be extended electrically.

The protective boot or cover helps keep the handcrank stowed when passengers or baggage might otherwise contact the handcrank and cause it to come unstowed. This in turn can cause the handcrank to bind against something when the gear is run electrically and the engaged handcrank turns. It is possible to strip out the handcrank connection or damage the gear motor if the handcrank meets resistance.



**American Bonanza Society
Air Safety Foundation**

Landing Gear Repair Guide

**For Beechcraft Bonanza, Debonair,
Baron and Travel Air**

Written by Ron Sanow
Edited by Thomas P. Turner

Additional editing and technical assistance by

Neil L. Pobanz, ABS lead technical advisor

Glen "Arky" Foulk

Richard H. Pedersen

Robert M. Olson

Arthur G. Miller

Robert G. Ripley

Robert E. Andrews

Stuart Spindel

ABS Technical Committee (2009-2010)

Tom Rosen, chairman

Ward Combs

ABS Technical Committee (2009-2010)

Arthur W. Brock, chairman

Ronald Lessley

Jon Luy

Craig Bailey

Tom Rosen

Nancy F. Johnson, ABS executive director

©2009 American Bonanza Society Air Safety Foundation www.bonanza.org
All rights reserved



American Bonanza Society Air Safety Foundation

Landing Gear Repair Guide

Table of Contents

Important notes on using this Guide	4
Checklist steps 1, 2 and 3: General maintenance and basic repair	4
Checklist Step 5: Discrepancies	5
Baron 55, 58 downlock block moves/tension is low	5
Baron 55, 58 downlock not over center and can be moved away from roller	5
Main landing gear lift leg down tension low	5
Main landing gear lift leg down tension high	9
Nose landing gear down tension low	9
Nose landing gear up tension low	10
Nose landing gear up tension high	10
Nose gear door actuator guide bent or broken	11
Nose gear plunger and pin needs inspection or adjustment	12
Nose gear retract rod mounting bolts loose	12
Setting nose gear tension	13
Checklist Step 6: Discrepancies	14
Main gear door hinge binding or seized	14
Main gear door wearing or chafing against gear strut	14
Rod end jamb nut chafes against landing gear bracket	14
Checklist Step 7: Discrepancies	14
Sector gear hits internal stop. Gear motor circuit breaker may trip	14
Checklist Step 8: Discrepancies	16
No landing gear warning	16
Warning indications occur when they should not	16
Gear runs when the squat switch rod is lifted	16
Checklist Step 9: Intentionally left blank	16
Checklist Step 10: Discrepancies	16
Movement or "slop" in main gear lift leg	16
Excessive play in lift leg knee	17
Movement in lift leg bushings at the forward and/or aft mounting boss	17
Checklist Step 11: Discrepancies	18
Inboard landing gear hinge attach bolts are loose	19
Cracks in inboard main gear door forward hinge bracket	19



American Bonanza Society Air Safety Foundation

Landing Gear Repair Guide

Table of Contents

Main gear inboard door cracks	19
Checklist Step 12: Intentionally left blank	20
Checklist Step 13: Discrepancies	20
Large uplock spring and/or spring attach points corroded or broken	20
Checklist Step 14: Discrepancies	21
Main landing gear retract rod end not centered	21
Nose landing gear aft retract rod end not centered	21
Checklist Step 15: Discrepancies	21
Pivot bolt frozen	22
Checklist Step 16: Discrepancies	22
Excessive play in nose gear	22
Checklist Step 17: Discrepancies	24
Excessive play in the steering idler arm rod attachment	24
Idler Arm mounting shaft is worn, requiring replacement	24
Steering yoke binding	25
Steering eye bearing worn	25
Checklist Step 18: Discrepancies	26
Oil leaking around circumference of the gearbox	26
Landing gear handcrank does not solidly engage	26
Worm drive gear end play	26
Gear operation is slow and/or inner gear doors do not fully close at the end of the down cycle	27
Checklist Step 19: Discrepancies	27
Lubrication	27
Checklist Step 20, 21: Intentionally left blank	27
Checklist Step 22: Discrepancies	28
Landing gear is rubbing on the inner gear door	28
Checklist Step 23: Discrepancies	28
Uplock cable tension	28
Checklist Step 24: Discrepancies	28
Main gear up stop bolt out of adjustment	28



American Bonanza Society Air Safety Foundation

Landing Gear Repair Guide

Table of Contents

Checklist Step 25: Discrepancies	28
Nose gear up tension is low	28
Checklist Step 26: Discrepancies	29
Gear stops before reaching specified extension	29
Dynamic braking coasting	29
Landing gear door hangs open on landing, but checks normal with the aircraft on jacks	29
Checklist Step 27: Discrepancies	29
Landing gear warning does not sound in flight but tests good on the ground	29
Checklist Step 28: Discrepancies	30
Manual handcrank slips during extension	30
Checklist Step 29, 30: Intentionally left blank	30
Checklist Step 31: Discrepancies	30
Disc outboard surface not in alignment with outboard edges of the torque plate bushings	30
Brake disc is corroded, cracked or worn	30
Brake disc measures below minimum thickness	30
Fluid leakage at brake cylinder piston	31
Brake hoses require replacement and/or installation	31
Checklist Step 32: Intentionally left blank	32
Checklist Step 33: Discrepancies	32
Checking brake canister fuel level after inspection	32
Checklist Step 34: Discrepancies	32
Overhauling the shimmy damper	32
Checklist Step 35: Discrepancies	33
Strut extension is low	33
Strut fluid is leaking	33



American Bonanza Society Air Safety Foundation

Landing Gear Repair Guide

Beechcraft designed a simple, strong, and reliable electro-mechanical landing gear system for the Bonanza that was also incorporated into the Travel Air and Baron models. The system has its idiosyncrasies that are addressed in this Guide and the *ABS Landing Gear Inspection Checklist*. By being alert to wear areas, keeping the system well lubed and adjusted with bolts tight, and replacing bushings when they show signs of wear, costly parts replacement and airplane-grounding landing gear mishaps can be avoided. This *Guide* identifies common squawks found on *Checklist* steps, and how to address issues not covered in the Beech maintenance manuals.

This *Guide* does not replace the need for following all manufacturer's guidance, or the requirement for mechanics to have and follow Beech shop and maintenance manuals. It is intended to supplement the factory manuals where experience shows more information is needed, or when specific techniques have been developed to accomplish factory-recommended tasks. In all cases if there is a discrepancy between this *Guide* and manufacturer's guidance, the manufacturer information takes precedence.

This *Guide* is designed to be used in conjunction with the *ABS Landing Gear Inspection Checklist*. Steps identified in this *Guide* correspond to the steps on the *Inspection Checklist*. **In all cases** if a discrepancy is noted see the Beech manuals for that serial number airplane first. If you can't find what you need see the appropriate Step in this *Guide*.

Important notes about landing gear inspection, adjustment and repair

Maintenance should begin with a complete inspection of the landing gear, listing all the discrepancies noted, assessing the condition, replacing worn parts, installing shims, and tightening / retorquing loose hardware **before** making any adjustments or repairs. It is vital the entire landing gear inspection be completed and discrepancies noted before making *any* adjustments to the rig or tensions of the landing gear system. Adjusting or repairing an item before the initial inspection is complete may prevent discovery of subsequent landing gear issues.

It is ABS' opinion that all repairs and adjustments included in this Guide are "minor" alterations or repairs. Final determination whether work is a "minor" or "major" repair rests with the authorized person completing the work.

Beechcraft landing gear up tensions and clearances are a function of the length of the retract rod, and should be addressed first. Landing gear down tension is a function of spring preload and should be addressed after the "gear-up" work is completed. This is followed by main and nose gear door adjustment. Many times worn bushings on the lift leg system can affect clearances and tensions.

Checklist Steps 1, 2, and 3: Aircraft walk-around review prior to work

Walking around of the aircraft on the ramp when it arrives is important to review its condition and to receive some history from the owner if something is noted out of the ordinary. Common squawks requiring simple adjustment, repair or replacement:

1. Strut height (or "bouncy" strut). Over-extended struts can be a sign the unit has been leaking over time and the oil level is low, with air providing the extension and little damping action because of low hydraulic fluid.
2. Uplock cables and Baron downlock cables frayed or broken.
3. Brake hose condition, routing, twisting, fraying or weeping.
4. Nose gear door actuator bellcrank top section of pin guide broken or missing.
5. Nose gear up-stop rubber bumper on the nose gear knee crossbrace missing.
6. On the nose gear lift leg, the pin assembly that actuates or closes the nose gear doors is bent, worn or missing.



American Bonanza Society Air Safety Foundation

Landing Gear Repair Guide

When disconnecting gear doors for inspection or repair purposes:

1. Leave the attach bolts, washers and nuts for the main landing gear doors in the oleo bracket to prevent gear door misalignment when they are reinstalled.
2. Remove the nose gear rods from the door actuator idler arm and the nose gear doors. Two AN960-3 washers between the rod end and idler arm makes removal and installation simpler with a 5/16-inch open wrench and a ratchet/socket for the nut.

Checklist Step 5: Check landing gear down tension on main and nose gear

Discrepancy: Baron 55, 58 main gear downlock block moves/tension is low

1. If the block moves down, there is no safety protection

Discrepancy: Baron 55, 58 downlock not over center and can be moved away from roller

1. Adjust downlock cable tension at the clevis if possible.
2. The cable clamp may have slipped, extending clevis to the witness hole. Adjust the clamp as per instructions the Maintenance Manual.
3. Some downlock cables are swedged to the uplock cable and are not adjustable.
4. Adjust clevis to pull main gear downlock over center and set.
5. Check and/or adjust cable tension to 52lbs +10-0 measured inside of cabin . Tension on cable can also be adjusted at the #3 wing rib. Check uplock cable tension because it will be affected when using this adjustment point.

Note : Lube downlock pivot points and cable pulley in the wheel well prior to performing adjustments to minimize drag and improve adjustment quality.

Discrepancy: Main landing gear lift leg down tension low

Four areas can cause down tension to be low:

1. Main landing gear retract rods, loose attachment hardware at the upper gear actuator retract arm.

Retract rod attach bolts can work loose and elongate the mounting hole in the gearbox top actuating arm.

1. Pull the landing gear motor or relay circuit breaker.
2. Crank the landing gear up 20 turns from the down position to release the tension on the gear. Stow the emergency gear handle (NEVER leave the handle engaged).
3. Check that the main gear retract rod attach bolt is tight at the actuator arm. Using a large standard screwdriver try to rotate the attach bolt without the weight of the main landing gear preloading the retract rod. Have a person lift up on the main wheel to remove the weight on the rod and attach bolt.





American Bonanza Society Air Safety Foundation

Landing Gear Repair Guide

Discrepancy: Main landing gear lift leg down tension low

Four areas can cause down tension to be low:

1. Main landing gear retract rods, loose attachment hardware at the upper gear actuator retract arm (continued).
 4. If the bolt is discovered loose, remove it and inspect bolt hole in the actuator arm for elongation. If good, reinstall the bolt, tighten to a standard torque for a shear nut, and safety. If the bolt hole is elongated replace the actuator arm. The bolt should be inspected for wear and replaced if worn.

Note: The main gear may be sagging off the up stop in the up position if the attach hardware is loose.

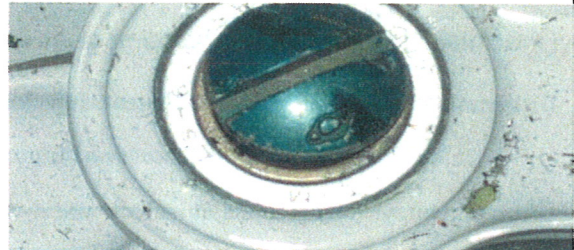

Loose bolt

5. Have a helper lift the main wheel to remove the preload from the retract rod. Inspect the bronze retainer for the bearing ball (P/N LS6). Ensure the retainer is not loose in the bearing race by rocking the retract rod left and right with the main wheel. Bearing retainers can work loose if the landing gear has been operated with loose hardware for a period of time. If the LS6 bearing or retainer is worn or loose, the bearing can be replaced in the retract rod.
 - (1) Pull landing gear circuit breaker.
 - (2) Lift main gear to compress the down tension spring.
 - (3) Remove the retract rod shear pin for the slip joint plunger. The shorter retract rod is easier to remove.
 - (4) Remove the attach bolt at top landing gear actuator arm.
 - (5) Remove the retract rod from the aircraft.
 - (6) Supporting the bearing boss, press the LS6 bearing out from the bottom of the rod.
 - (7) Press in a new bearing careful not to apply pressure to the ball or retainer, when the bearing is seated, stake the bearing boss with a center punch after seating the bearing.
 - (8) Reinstall the retract rod. Slide the tube over the plunger, install the attach bolt to the actuator arm, torque, and safety.
 - (9) Lifting the main gear to compress the down tension spring, install the retract rod shear pin and safety.
 - (10) Check main gear down tension. 45 to 65 pounds.

Continued on next page



American Bonanza Society Air Safety Foundation

Landing Gear Repair Guide

Discrepancy: Main landing gear lift leg down tension low

2. Main landing gear retract rod flexing/bending in the flat area. The flexing of the rod will reduce down tension to the lift leg by not fully compressing the spring on the plunger.

1. Inspect the flat area of the retract rod for flexing up or down. Preload the rod by lifting the main wheel and collapsing the plunger on the outboard end of the rod, or watch the operation of the rod during an extension cycle for flexing. A frozen plunger may cause this problem.

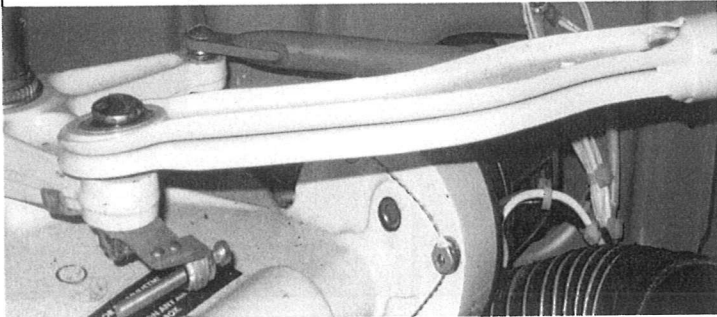

Flat area of the retract rod

2. If the rod is flexing / bending replace the retract rod.
 - (1) Pull the landing gear circuit breaker.
 - (2) Lift the main gear to compress the down tension spring.
 - (3) Remove the retract rod shear pin for the plunger. The shorter retract rod is easier to remove.
 - (4) Remove the attach bolt at the top of the landing gear actuator arm.
 - (5) Remove the retract rod from the aircraft.
 - (6) Replace the retract rod. Be certain the curved area of the rod is in the correct orientation, going aft on the right side and forward on the left side. Slide the tube over the plunger, install the attach bolt to the actuator arm, torque, and safety. Lift the main gear to compress the down tension spring. Install a new or serviceable retract rod shear pin, and safety.
 - (7) Check main gear down tension. 45 to 65lbs.
 3. Rig the "up" travel in the wheel well first. There should be 0.060 clearance between the lift leg knee and the wing. Adjust the up stop per instructions in the applicable Beechcraft Maintenance or Shop Manual. This adjustment is a function of the retract rod length and should be accomplished first.
 4. Check down tension. Install washers as needed under the inboard end of the spring to increase down tension, per instructions in the applicable Beechcraft Maintenance or Shop Manual. Ensure the plunger is compressing and the spring is not stacking.
3. Main gear retract rod end jam nut not tight against the plunger.
 1. Use a wrench to insure the jam nut is tight against the plunger. A backed-off jam nut will reduce tension on the spring and create low down tension readings.



American Bonanza Society Air Safety Foundation

Landing Gear Repair Guide

Discrepancy: Main landing gear lift leg down tension low

2. Tighten the jam nut and recheck down tension. Check that the retract rod is free to rotate. The left-hand rod has slightly more rotation than the right-hand rod, but they should both be free to rotate. If they don't, the rod itself will twist.

Retract rod

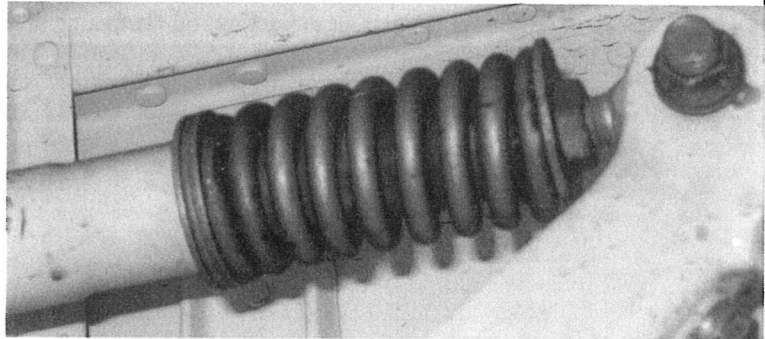

4. Retract rod spring tension low

Install additional washer if spring is not stacking or replace the spring if it is weak and close to stacking.

- (1) Position landing gear about 20 manual handcrank turns from full down.
 - (2) Compress the spring and remove the retract rod shear pin retaining plunger.
 - (3) Remove the rod end attach bolt at the "V" Brace.
 - (4) Remove the plunger and install one or more P/N 100951S063XP washers in the inboard end of the spring. The maximum number of allowable washers is five (5).
 - (5) Reinstall the plunger and spring washers on the retract rod.
 - (6) Install the rod end attach bolt at the "V" brace.
 - (7) Compress the spring and install a new or serviceable retract rod shear pin, washer and cotter pin to retain the plunger.
 - (8) Cycle the gear and recheck main gear down tension at 45-65 pounds.
5. Landing gear incorrectly rigged, not full travel down and inboard gear doors fully closed
This is an unlikely cause of low down tension
 - (1) Position landing gear down about 20 manual handcrank turns from full down.
 - (2) Disconnect the inboard gear door link rod from the inboard gear door actuator rod. This is to provide more working space. The inboard door will hang straight down and out of the way.
 - (3) Set the landing gear gearbox internal clearance per instructions in the applicable Beechcraft Maintenance Manual or Shop Manual.
 - (4) Reattach the inboard landing gear link rod to actuator rod per the applicable Beechcraft Maintenance or Shop Manual.



American Bonanza Society Air Safety Foundation

Landing Gear Repair Guide

Discrepancy: Main landing gear lift leg down tension high

There are two areas that can cause this problem.

1. Frozen/binding retract rod plunger.
 - (1) Position landing gear down about 20 manual handcrank turns from full down.
 - (2) Remove the clevis pin retaining the plunger (lube with penetrant oil to assist in freeing the plunger).
 - (3) Remove the plunger and inspect its condition. Determine the root cause of the binding. If corrosion is the cause, clean the retract rod and plunger. Either or both may require replacement depending on the severity of corrosion damage.
 - (4) Check the retract rod flat area above the gear box for bending or flexing. (A bent retract rod requires replacement).
2. Over-tension on the tension down spring.
 - (1) Check down tension spring for stacking (too many washers under a weak spring).
 - (2) Position landing gear down about 20 manual handcrank turns from full down.
 - (3) Remove the retract rod shear pin, retaining the plunger.
 - (4) Remove the retract rod attach bolt from the lift leg "V" brace.
 - (5) Separate the plunger from the retract rod.
 - (6) Replace the spring and install washers as required to set down tension to specifications.
 - (7) Reassemble the plunger, retract rod and retract rod shear pin.
 - (8) Check the gap between coils, maintaining a minimum total gap of 0.060 between the coils after the retract rod shear pin is reinstalled. The total gap is the sum of all gaps between the coils.
 - (9) Recheck the main landing gear down tension.

Discrepancy: Nose landing gear down tension low

Adjustment of the nose gear tension for the down position should not be accomplished until nose gear up tension is checked and is within specifications (30 to 35lbs) with the nose gear doors disconnected. The nose gear up tension is set by the length of the retract rod, to preload the nose strut against the up stop bumper attached to the nose gear lift leg.

IMPORTANT NOTE: The forward nose gear retract rod needs to be the correct length prior to making adjustments to the up tension. Have no more than three threads (two is good) showing between the rod end and the jamb nut where the rod attaches to the nose gear lift leg. A short aft nose gear retract rod (nose gear retract idler arm to gearbox) and a long forward rod (lift leg to idler arm) will position the nose gear idler arm angle too far aft. In this condition when the gear is retracted the idler arm rotates aft to a position where it is no longer rotating, and the aft rod applies a direct pull from the idler arm to the nose gear actuator arm on the gearbox. The result is the forward rod does not move and the gearbox is still traveling to its stop, preloading the aft section of the nose gear retract system. ABS has observed this condition in numerous rod end failures.



American Bonanza Society Air Safety Foundation

Landing Gear Repair Guide

Discrepancy: Nose landing gear down tension low

1. Frozen/binding retract rod plunger.

- (1) Position landing gear down about 20 manual handcrank turns from full down.
- (2) Remove the clevis pin retaining the plunger (lube with penetrant oil to assist in freeing the plunger).
- (3) Remove the plunger and inspect its condition. Determine the root cause of the binding. If corrosion is the cause, clean the retract rod and plunger. Either or both may require replacement depending on the severity of corrosion damage.

2. Setting nose gear up tension with the doors disconnected

- We recommend removing the nose gear door actuator rods from the actuator bellcrank to prevent the door rods from hanging up on the retract rod or nose gear during cycling .
- Bungee cords work well to hold the disconnected nose gear doors fully open.
 - (1) Disconnect the nose landing gear doors actuator rods.
 - (2) Remove the rods from the nose door gear actuator idler arm and gear doors. Two AN960-3 washers between the rod end and the idler arm makes removal and installation simpler with a 5/16 inch open-end wrench and a ratchet wrench for the nut.
 - (3) Ensure the rod end jamb nuts are tight on the rod ends in order to get an accurate tension check.

Discrepancy: Nose landing gear up tension low

Check that the nose gear shear pin is not bent prior to adjusting the nose gear up tension.

- (1) Looking forward, rotate the aft (gearbox to idler arm) retract rod clockwise in one-half turn increments to increase up tension.
- (2) Pull the landing gear motor circuit breaker.
- (3) Position landing gear up 10-15 manual handcrank turns from full down for easy access to aft retract rod actuator attach bolt.
- (4) The aft retract rod is a telescoping adjustment. Shorten the rod to increase up tension. Loosen the jam nuts on each end for coarse adjustments, or turn the aft rod end in half turn at a time to increase the up tension to 30 to 35 lbs. Looking forward, turn the aft (idler arm to gearbox) retract rod in one-half turn increments counterclockwise to decrease up tension or clockwise to increase up tension.



Landing Gear Repair Guide

Discrepancy: Nose landing gear up tension high

- (1) Looking forward, rotate the aft (idler arm to gearbox) retract rod counterclockwise in one-half turn increments to decrease up tension.
- (2) Pull the landing gear motor circuit breaker.
- (3) Position landing gear up 10-15 manual handcrank turns from full down for easy access to aft retract rod actuator attach bolt.
- (4) The aft retract rod is a telescoping adjustment. Lengthen the rod to decrease tension. Loosen the jam nuts on each end for coarse adjustments, or turn the aft rod end in half turn at a time to increase the up tension to 30 to 35 lbs. Looking forward, turn the aft (idler arm to gearbox) retract rod in one-half turn increments counterclockwise to decrease up tension or clockwise to increase up tension.

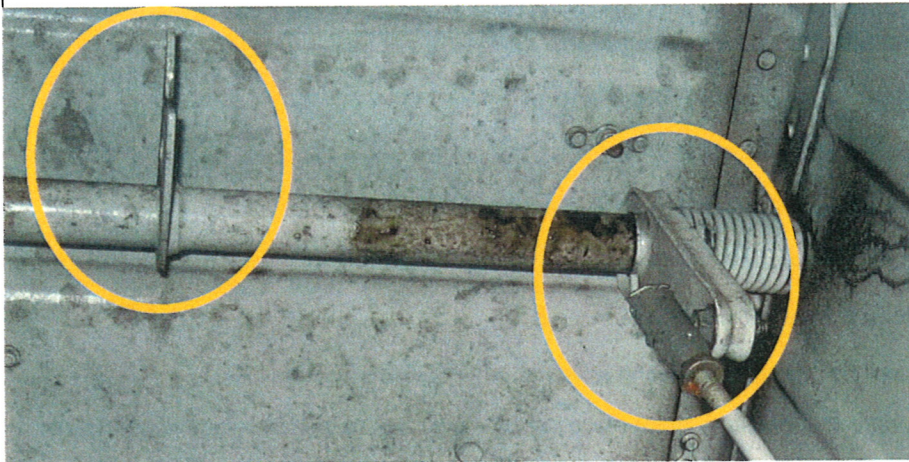

Nose gear door actuator arm (right) and door actuator pin guide (left)

Discrepancy: Nose gear door actuator guide bent or broken

1. Check the nose gear door actuator guide, especially the upper side of the guide, for cracks or to see if it is broken off. Lubricate the guide with a light grease to reduce wear on the guide and on actuating pin.
2. Check for damage on the door actuator pin.
3. On single-engine airplanes with cowl flaps, check for wear on the cowl flap actuator cross-shaft bearing plates at the ends of the shaft, attached to the nose gear tunnel. The nose gear door actuator rotates on this shaft. Excessive wear on the bearing plates can create alignment problems with the guide and pin.
 - (1) Replace worn bearing plates.
 - (2) Grooves worn in the shaft may be welded and then lathed to shaft diameter.
4. Cracks aft of the forward door hinge on the inside or the door may be repaired with a doubler, structural adhesive and blind rivets.

Repair doubler





Landing Gear Repair Guide

Discrepancy: Nose gear door actuator guide bent or broken

5. Nose gear door hinges wear and create hole elongation at hinge attach bolt.

- (1) Lubricate hinge with a LPS2-type lube.
- (2) Use the old, worn hinge as a template to drill a new hinge.
- (3) Normally the aft hinge comes from the factory with one predrilled hole. If the hole does not match up to the removed hinge, countersink it on both sides, squeeze in a rivet, shave the rivet and drill it to match.

Discrepancy: Nose gear plunger and shear pin needs inspection or adjustment

If the nose gear up or down tension was noted to be high during the tension checks the shear pin on the plunger should be checked for condition prior to making any nose gear adjustments.

Inspect for condition. If it shows any signs of stress replace the pin.

- (1) Pull the landing gear motor circuit breaker.
- (2) Slightly retract the landing gear manually, stopping after only a few turns..
- (3) Stow the handle. Leave the circuit breaker pulled.
- (4) Gain access to the nose gear plunger and tension spring.
- (5) Push up slightly on the partially retracted nose gear and remove the shear pin.
- (6) Inspect the pin and plunger for condition. Replace as necessary. Secure the shear pin with a washer and cotter pin.
- (7) Extend gear fully down to insure the retract rod plunger is moving forward, compressing the spring.
- (8) If the rod is not compressing, check for bushing wear on the lift leg knee. A worn bushing will cause lower tension because extra travel will be required to move the brace assembly over center.

Discrepancy: Nose gear drag brace bracket mounting bolts loose

Loose bolts and movement of the bracket will affect up and down tension settings. This condition is frequently found at ABS-ASF Service Clinics.

- (1) Jack the aircraft.
- (2) Slightly retract the landing gear with the Manual Extension checklist from the POH, stopping after only a few turns. Stow the handle and leave the circuit breaker pulled.
- (3) Place a finger on the flat portion of the forged nose gear lift leg assembly, above the two bolts and also making contact with the inboard arm.
- (4) With your other hand, move the nose gear forward and aft and feel for movement between the forged lift leg and the inboard arm. There should be no movement detected between the pieces.



American Bonanza Society Air Safety Foundation

Landing Gear Repair Guide

Discrepancy: Nose gear retract rod mounting bolts loose

- (5) If there is movement, the bolt holes in the inboard and outboard arms are worn and should be replaced. Also replace the attaching hardware.

Beechcraft recommends a 2,000 hour inspection of the two (2) bolts and two (2) drag brace brackets. (NOTE – the Illustrated Parts Catalog refers to the brackets as inboard and outboard arms.)

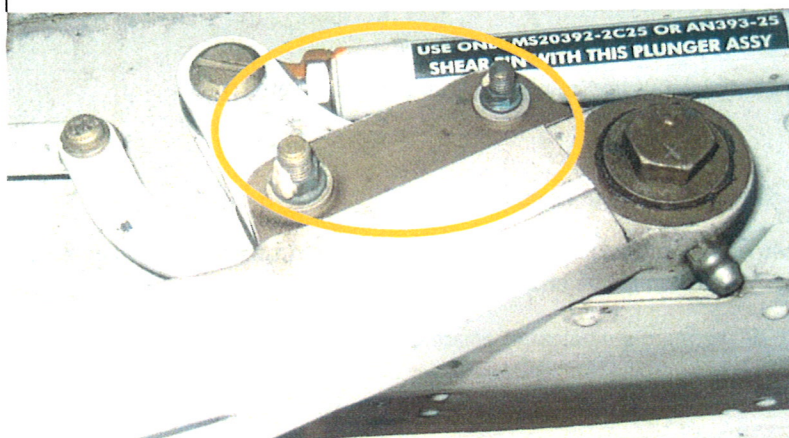

Retract rod mounting bolts

During inspection of the landing gear it is also a good procedure to check retract rod shear pins to see if they will rotate freely when the gear is not fully down and no tension on the lift leg. Compress the spring partially by pushing or pulling the landing gear up, then rotate the pin with your fingers or small needle nose pliers (the minor bite of needle nose pliers will help prevent tool marks on the top of the pins).

Setting nose gear tension

Nose gear down tension is set by the addition of spacers between the nose gear retract rod plunger and the spring to increase tension, or by replacing the compression spring. After all adjustment, repair or replacement is complete, adjust the nose gear down tension:

- (1) Pull the landing gear motor circuit breaker.
- (2) Position the landing gear about 10 manual handcrank turns from full down.
- (3) Stow the handle.
- (4) Remove the shear pin retaining the nose gear plunger.
- (5) Remove the forward retract rod attach bolt from the lift leg. Normally a long plunger is installed so the forward rod must be removed to install the washers.
- (6) A maximum of three washers can be installed according to the latest Beech shop manual revision.
- (7) Reinstall shear pin, and safety.
- (8) Recheck tensions. If the nose gear tension is still low, replace the compression spring. New springs may be shimmed as necessary.
- (9) If the nose gear up tension is high (exceeds 35 pounds pull) and the down tension is low (less than 55 pounds), lengthening the aft retract rod by a small counterclockwise rotation (looking forward) may bring both tensions into compliance.



American Bonanza Society Air Safety Foundation

Landing Gear Repair Guide

Checklist Step 6: Disconnect main gear outboard doors.

Discrepancy: Main gear door hinge binding or seized

Hinge attach bolts need to be tight against the hinge bushings to prevent elongation of hinge attach bracket bolt holes.

- (1) Determine if the hinge is binding or seized on the bushing.
- (2) Inspect hinge attach brackets on the wing rib for cracks.
- (3) Lubricate, repair or replace hinges, bushings and/or hinge attach brackets as necessary.

Discrepancy: Main gear door wearing or chafing against gear strut

A main gear door may be rigged too tight, allowing it to chafe against the landing gear strut when it is retracted. This condition can cause cracking on the gear door at the bracket attach areas.

Adjust gear doors to clear the strut only *after* all the main gear clearances are checked and set to specifications.

Discrepancy: Rod end jamb nut chafes against landing gear bracket

The outboard gear door forward attach rod should have two AN960-3 washers spacing the rod from the landing gear bracket, to prevent the rod end jamb nut from chaffing into the bracket.

Checklist Step 7: Checking landing gear gearbox internal clearance and gearbox area.

Landing gear gearbox internal clearance (distance between the sector gear and the physical stop inside the gearbox) needs to be checked in both directions in accordance with instructions in the applicable Beechcraft Maintenance or Shop Manual for the aircraft model and serial number. The sector gear moves 180 degrees in each direction.

Discrepancy: Sector gear hits internal stop. Gear motor circuit breaker may trip.

1. Find the root cause why gear box is over-traveling prior to removing the gear box for inspection.
 - (1) Normally a gear motor or dynamic brake relay causes this problem.
 - (2) Check for brake coasting, if you have a known good motor to slave in. This will help check the dynamic brake condition to start the discovery process.
 - (3) Check the condition of limit switches and switch actuator tabs. Sometimes tabs or adjustment screws are discovered bent or mis-aligned, thus changing the rigging.
 - (4) Check for a limit switch with high resistance or that does not open the circuit. Normally when this happens the landing gear motor circuit breaker will pop when it hits the end of its travel.



Landing Gear Repair Guide

Discrepancy: Sector gear hits internal stop. Gear motor circuit breaker may trip.

2. Remove the gearbox in accordance with the applicable Beech Maintenance or Shop Manual. Removing the landing gear motor and handcrank makes it easier to remove the gearbox assembly.
3. Overhaul the landing gear gearbox /actuator per instructions in the applicable Beech Maintenance or Shop Manual. **NOTE:** Because of the complexity of overhauling the gear actuator, ABS recommends the unit not be overhauled in the field, but that it be sent to a Beech landing gear specialty shop. However, if you overhaul it yourself:

(1) 28 volt systems will suffer more internal damage to the sector gear than the 14 volt systems because of the speed differential.

(2) ABS recommends non-destructive inspection (NDI) of the gearbox parts when overhauled. Inspect sector gear teeth engagement to the worm drive gear at both ends of the gear. Sector gear teeth become compressed (closer together) from hitting the stop. The gear will show signs of metal trimmed off of the lands of the teeth and will not fully engage the worm gear. Sector gears that do not fully engage the worm gear teeth need to be replaced.

Worn gear teeth



(3) Check the spline drive shaft for damage. Slide the sector gear from end to end. If the sector gear spline hangs up or needs force to slide on the shaft, it could have a twist or slight bend.

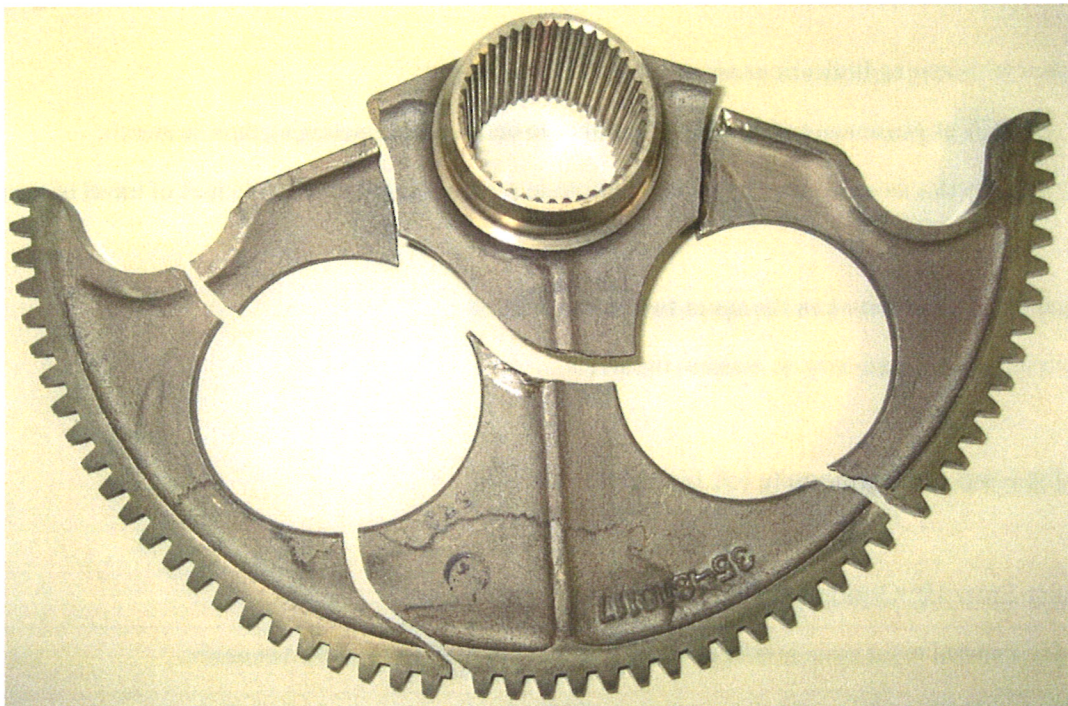

The sector gear from a 28-volt airplane that hit the internal stop on both sides repeatedly for a long period of time. The sector gear became work hardened and brittle, and eventually shattered.



American Bonanza Society Air Safety Foundation

Landing Gear Repair Guide

Discrepancy: Sector gear hits internal stop. Gear motor circuit breaker may trip.

- (4) Check the dynamic brake relay. Plan to activate the limit switch on the left side of the gearbox half way through the direction of gear travel so you will not have a tool caught in the linkage. With full system voltage external power (14- or 28-volt as applicable) applied to the aircraft, check the dynamic breaking action in both directions. The landing gear operation should stop instantly during the cycle when the limit switch is activated.

Checklist Step 8: Check squat switch operation

Discrepancy: Landing gear warning horn does not sound

- (1) Check horn operation with throttle at idle and gear retracted. The throttle switch uses same horn and annunciator as the squat switch.
- (2) Check for an open (broken) wire in the wheel well strut area. Over time wires can break if tied too tightly near the top of the strut, or at the forward pivot point against the front wing spar. Set the horn to activate around 3/8 to 1/2 inch of travel of the actuator rod at the squat switch.
- (3) Check alignment and electrical resistance to detect a malfunctioning throttle switch.
- (4) Check alignment and electrical resistance to detect a malfunctioning squat switch.

Discrepancy: Warning indications occur when they should not

- (1) Check alignment and electrical resistance to detect a malfunctioning throttle switch.
- (2) Check this adjustment by setting the horn to activate at around 3/8 to 1/2 inch of travel of the actuator rod.

Discrepancy: Gear runs when the squat switch rod is lifted

The switch is not opening internally. Replace the switch.

Checklist Step 9: Intentionally left blank

Checklist Step 10: Check Lift Leg Joint Play

The lift leg attached to the main gear strut bushing should not have any visible movement.

Discrepancy: Movement or "slop" in main gear lift leg

- (1) Move the strut left to right to check for end wear. If movement is noted replace the bushing.



American Bonanza Society Air Safety Foundation

Landing Gear Repair Guide

Discrepancy: Movement or “slop” in main gear lift leg

- (2) Check lift leg attach bolt at the strut that it is not rotating or loose.
- (3) Do not over tighten the attach bolt at the strut (25 to 75 inch pounds of torque on the nut).

Discrepancy: Excessive play in lift leg knee

A small amount of end play is normal, as is some lateral side play to assist in gear alignment during the extension and retraction cycle.

- (1) Excessive bushing wear will affect down tension, because the retract rod will travel further to push the lift leg over center.
- (2) The landing gear strut will also sag in the up position. The wing-to-knee clearance will remain the same, but the strut may start wearing on the inboard gear door as a result of the bushing wear.
- (3) If play is excessive replace the bushing and check the bolt for wear.
- (4) When reinstalling, the uplock roller and bolt head must be on the aft side of the lift leg.
- (5) Lift legs may be sent out for oversize bushings to be installed at the center knee join. Check the Aircraft Technical Resources List on the ABS website for sources.

Discrepancy: Movement in lift leg bushings at the forward and/or aft mounting boss

Bushings in this area do not wear much and are seldom replaced. If movement is discovered:

- (1) Check the mounting pin for wear.
- (2) If the pin is good, replace the bushing.
- (3) If the pin is worn, replace the pin and the bushing.

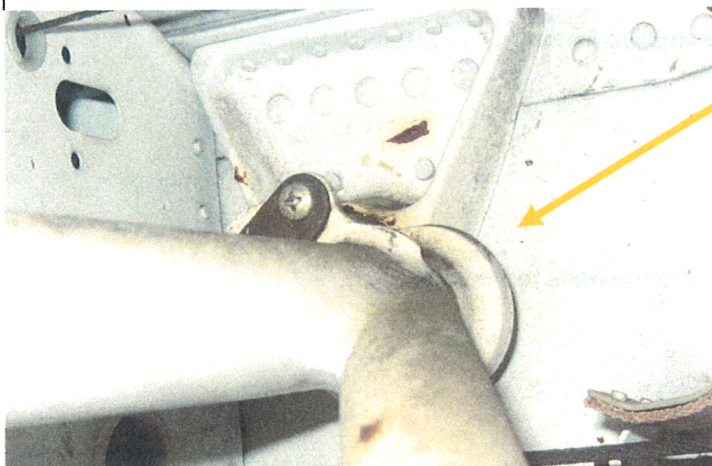

Mounting boss and lift leg bushing



American Bonanza Society Air Safety Foundation

Landing Gear Repair Guide

Discrepancy: Movement in lift leg bushings at the forward and/or aft mounting boss

Bushing replacement is difficult:

1. Remove the lift leg.
 - (1) Removing the mounting boss attached to the rear spar:
 1. Remove the grease fitting
 2. Drill a hole in the inner diameter of the bushing through the spar web, and debur.
 3. Tap threads on the inside of the bushing.
 4. Use a slide hammer to remove the bushing. Sometimes using a heat gun on the fitting and some Freeze-It on the bushing will help free the bushing.
 - (2) Replacing the bushing in aft spar mounting boss:
 1. Using a bolt the same size as the inner diameter of the bushing, put the bolt through the spar. Install a thick washer and plain nut on the spar side.
 2. Gently press the bushing into the boss by tightening the nut on the bolt. Freezing the bushing before installation and heating the boss with a heat gun will help the process.
 - (3) Drill the grease fitting port and apply metal tape over the hole in the rear spar web to prevent water intrusion.
 - (4) Replacing the bushing on the front spar mounting boss:
 1. Use the same process as the aft spar mounting boss, but the fuel cell needs to be drained and pulled back for clearance.
 2. Remove the inboard level sender, unsnap the fuel cell to gain access to boss area, then pull the cell away from spar to clear drill. Grease on the tip of the drill will help catch metal filings.
 3. Use same procedure as given for the aft spar mounting boss.

Checklist Step 11: Retract rod slip joints

See Checklist Step 5 section for discrepancies and methods to address them.



Landing Gear Repair Guide

Checklist Step 11: Main gear inner door hinges and bushings

Discrepancy: Inboard landing gear door hinge attach bolts are loose

- (1) Check for hole elongation.
- (2) If the holes are good, retorque the bolts and check for bushing seizing.
- (3) If hole elongations are too large, replace the hinge brackets.

Discrepancy: Cracks in inboard main gear door forward hinge bracket

Forward hinge brackets will crack occasionally on the forward and aft sides of the access hole. You may have to remove the lower wing root fairing for access.

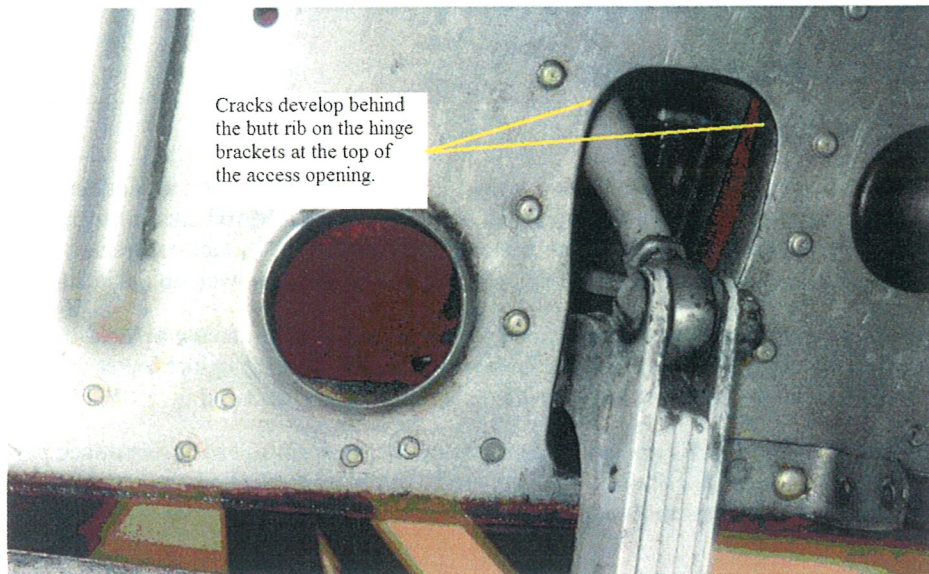

- (1) Manufacture a small doubler with a 90-degree angle to reinforce the bracket.
- (2) Install doubler with structural adhesive and rivet to the butt rib with Cherrymax-type blind rivets.

Discrepancy: Main gear inboard door cracks

Inboard gear door cracks normally develop on the inside of the door aft of the forward hinge. Welding the cracks will not hold. It has been tried many times and new cracks follow along the welds.



Landing Gear Repair Guide

Discrepancy: Main gear inboard door cracks

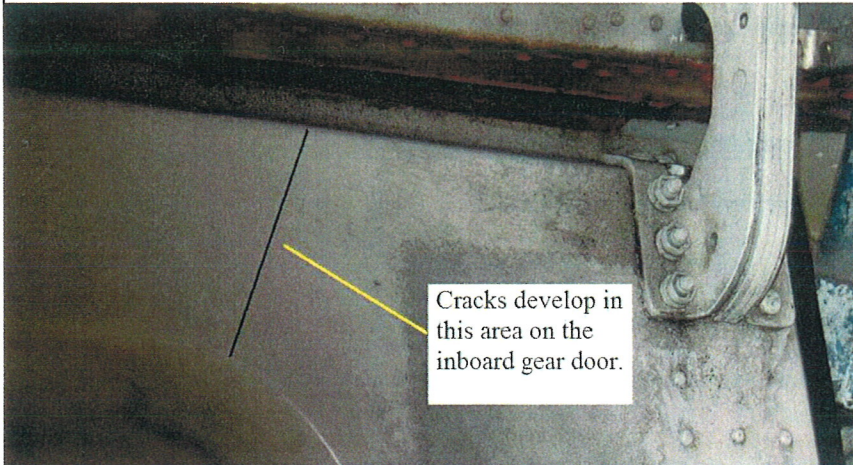

A locally manufactured doubler (this may take some craftsmanship) installed with structural adhesive and blind rivets makes a good repair. Use scrim cloth with the adhesive.

Checklist Step 12: Intentionally left blank

Checklist Step 13: Uplocks

The main gear uplocks prevent heavy loads applied to the retract system in turbulent air and under G-loading. Adjustment of the uplock clearance should be on the wide side, close to .020. As the rod ends wear the gear will sag, closing the gap towards the minimum clearance .010. This system needs the cable bolt, uplock bracket attach bolt, and spring attach points to be inspected well for wear. If the uplock clearance is reset, recheck uplock cable tension.

Tygon tubing on the cable housing in the wheel well is very important. The pilot should look for it on a preflight when checking the rollers. The tubing's purpose is to guide the uplock cable past the uplock roller and grease fitting during gear retraction. Do not install a grease fitting cover on the uplock roller grease fitting.

Lubrication of the uplock cable attach bolt, uplock bracket attach bolt, springs, and spring attach points is often overlooked. Lube with a heavy lube LPS-2 or -3 type. There are no bushings on the bracket; good lubing will reduce the wear significantly and prevent corrosion on the springs.

Discrepancy: Large uplock spring and/or spring attach points corroded or broken

The large uplock spring between the uplock bracket and the wing rib is one of the least expensive and one of the most important parts on the airplane. The spring holds the uplock bracket clear of the gear if the uplock cable breaks. But if the large spring breaks or a spring attach point fails when the gear is retracted, it is a very good possibility the gear will not extend.

1. Replacing the spring:

- (1) Position the gear in a partially retracted position. This puts the spring in a relaxed position, making replacement easier.
- (2) Another way to relieve pressure on the spring is to remove the uplock assembly clevis bolt.



American Bonanza Society Air Safety Foundation

Landing Gear Repair Guide

Discrepancy: Large uplock spring and/or spring attach points corroded or broken.

- (3) Removing the spring: Tie a loop of safety wire through the hook end of the spring. Use a screw driver in the loop of wire, stretch out the spring, and use needle-nose pliers to remove the spring from the uplock bracket and rib.
- (4) Installing the spring: Attach the new spring to the rib. Tie a loop of safety wire to the spring. Stretch the spring and hook it to the uplock bracket. Cut and remove the wire.

Checklist Step 14: Check Retract Rods and Rod Ends

Rod ends should be able to rotate freely when the load is removed, and not bind during gear operation.

Discrepancy: Main landing gear retract rod end not centered

1. The main landing gear retract rod LS6 bearing is fixed in the rod.
2. A simple method to center the rod end at the lift leg:
 - (1) Rotate the retract rod clockwise (looking inboard) until it stops.
 - (2) Holding the rod in this position, loosen the jamb nut and rotate the outboard rod end clockwise until it stops.
 - (3) Tighten the jamb nut. The rod will now rotate freely during its full travel.

Discrepancy: Nose landing gear aft retract rod end not centered

The forward end of the rod is fixed in the idler arm bellcrank, and the aft rod end is easily adjusted at the nose gear actuator on the bottom of the gearbox.

- (1) Hold up pressure up on the nose gear.
- (2) Turning the rod clockwise until it stops.
- (3) Turn the rod end at the actuator rod clockwise and tighten jamb nut.
- (4) Check for freedom of movement in both directions.

Checklist Step 15: Main Landing Gear Hinge/Pivot attach bolts and fittings.

The main landing gear "A" frame should not have in excess of .016 free play fore and aft between the forward and aft spar attach fittings (pivot bolts). If fore and aft clearance exceeds .016 then shim to fit. A .016 shim, p/n/ 100951-S-016XF and a .032 shim, p/n 100951-S-032XF are available from RAPID. Juggle shims to align the lift leg arm with the oleo attach point.



Landing Gear Repair Guide

Discrepancy: Pivot bolt frozen. The bolt rotates with the landing gear, but does not rotate when attempting to turn it with a wrench.

- (1) Remove the cotter pin.
- (2) Back the nut off until it is even with the end of the bolt.
- (3) Apply penetrant oil and allow the oil to soak in for a period of time.
- (4) Tap the end of the hinge bolt with a light hammer. Ensure the nut is backed off and to prevent mushrooming the end of the bolt. If this will not free the bolt using an impact gun (rivet gun with flat set) set to low pressure may be required to free up the pivot bolt.
- (5) Replace the bolt if corrosion is present.
- (6) Install the bolt and bushing.
- (7) Check strut endplay and shim if required to .016 clearance between spar fitting and strut, per instructions in the applicable Maintenance or Shop Manual.

Pivot bolt



Checklist Step 16: Check for nose gear play.

Excessive wear will cause the nose wheel to shimmy. The torque knee center pivot bolt should rotate with finger pressure, but should not have any free play. The bushings at the tow pin and brace should have very little play. This check cannot be done when the aircraft is on jacks because the torque knees are preloaded from the pressure inside of the strut. If there is significant wear in the strut brace bushings, cylinder, or piston, ABS recommends sending the unit out for overhaul. See www.bonanza.org for a list of landing gear overhaul facilities.

Discrepancy: Excessive play in nose gear

1. Shim or replace the torque knee bushing.
 - (1) The aircraft must be on the ground and the nose strut compressed to prevent the nose strut piston from coming out of the cylinder and brace assembly.
 - (2) Install a suitable tail stand support.
 - (3) Measure end play between the torque knee link and attaching boss. Wear may be present and the width of the new bushing flanges may not be wide enough to take up the gap.
 - (4) Replace the bushing if needed.
 - (5) As required, fabricate and install a thin shim to space the bushing flange out a few thousandths of an inch.



Landing Gear Repair Guide

Discrepancy: Excessive play in nose gear.

2. Check the vertical movement of the strut cylinder and end cap.
 - (1) The maximum allowable wear limit is 0.012 inch.
 - (2) A laminated shim is available.
 - (3) Repair per instructions in the applicable Maintenance or Shop Manual.

Top of the nose gear strut. Note the grease fitting is installed incorrectly, a common mistake. The fitting should be installed pointing *down* to avoid interference during gear transit and to facilitate greasing.

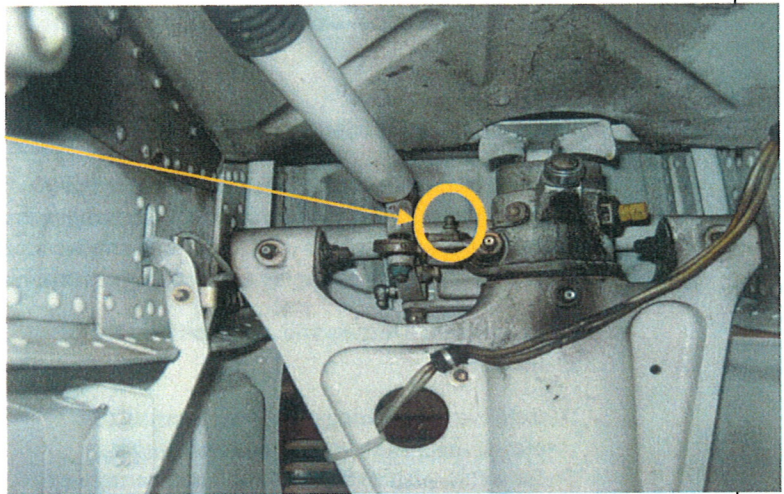

3. Check for a loose nose gear retract rod aft attach bolt, on the bottom of the gear actuator.
 - (1) Remove the bolt and check hole in arm for wear. The serviceable limit is .009." Note: this dimension comes from Beechcraft and is from the original engineering drawings. If this bolt is left loose for an extended period of time, it has a tendency to wear out the hole. Replace the bolt if it is worn.
 - (2) If the hole exceeds the limit replace the actuator arm.
 - (3) Inspect the rod end for a loose brass ball retainer.
 - (4) Replace rod end if there is any movement in the retainer.
 - (5) If the aft nose gear retract rod end at the gearbox actuator has a grease fitting installed, consider replacing the rod end with one that has no grease fitting.
 - (6) Tighten the nut on the bolt until safety castellation lines up and the castellated nut is tight. If nut does not line up remove washer under the nut, sand the washer surface, reinstall and tighten. Repeat the process until the cotter pin hole lines up with the nut tight.
 - (7) To make it easier to get the castellated nut aligned with the cotter pin hole, remove the bolt. With a felt tip marker put a line on the head of the bolt to identify the direction of the cotter pin hole. This will then be visible when you locate the cotter pin hole above the arm where it cannot be seen without a mirror.



Landing Gear Repair Guide

Checklist Step 17: Check Nose Gear Steering Linkage

Nose gear steering system linkage wear areas are at the steering idler bellcrank on the left keel, and the steering yoke attached to the nose strut cap. Keep the hardware snug on the two link arms forward of the nose strut to prevent wear. The steering yoke has a bushing about 5/8" long and a steering eye bearing that takes almost the entire steering load. (The steering yoke transfers the load from the rudder pedals to the nose strut cap). This bushing has around a 300 cycle limit. Replace this bushing, P/N 76A7-020, when it shows signs of wear. Replacement is a simple process and reduces the free play in the steering system. Generous lubing of the steering idler arm bushings and bearing surfaces with LPS 2 will reduce wear, as there is no grease fitting for the bearing surface. Loose steering cap bolts or worn bolt holes in the cap will produce excessive play in the nose steering system. NOTE: If the steering stop cone is not free to rotate this may cause a rigging issue by displacing the rudder.

Discrepancy: Excessive play in the steering idler arm rod attachment

Wear occurs on the retaining collar, bushing, and idler arm shaft. A clevis pin holds the collar in place. Every time the steering linkage moves the idler arm fore and aft the arm experiences a side load as well. This can elongate the collar mounting hole. Replacing worn collars reduces bushing wear. Excessive left/right movement of the steering rods at the idler arm upper bolt may be because the two bushings that prevent side-to-side motion are missing from the bolt.

- (1) Remove the steering rod attach bolt on top of the arm.
- (2) Remove the bushings in the aft steering rod clevis. Inspect the clevis end and bushings for wear. Inspect the LS4 rod end bearing in the forward steering rod aft rod end for wear. Worn LS4 bearing can be replaced in the rod end.
- (3) Remove the retaining collar and idler arm from the shaft. Use a new bushing to press out the old bushing, then install the new bushing. Inspect the idler arm mounting shaft for wear.
- (4) Reinstall arm on shaft, replace collar if clevis pin hole is elongated. Reinstall steering rods.

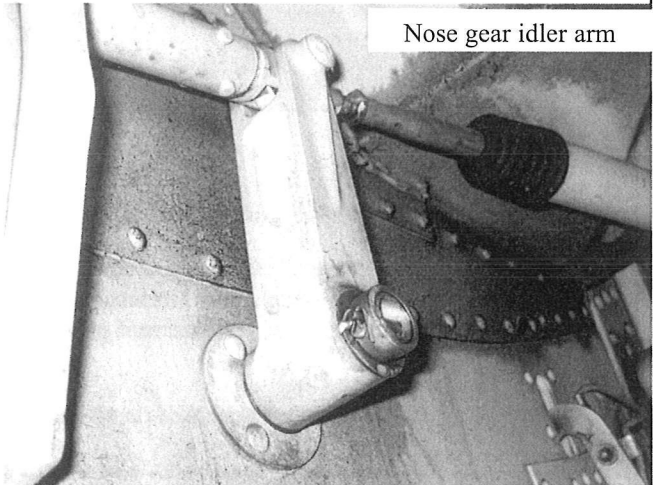

Discrepancy: Idler Arm mounting shaft is worn, requiring replacement

The shaft is riveted to the left keel in a frame.

- (1) Drill through the center of the shaft to cut the rivets attaching the shaft to the frame. Be careful not to drill into the frame. Remove the rivets attaching shaft to the keel. Remove the shaft.
- (2) Fit a new shaft.
- (3) Match up and drill keel holes. Mark the frame holes, remove the shaft and drill holes with drill press. Install the shaft, rivet it to the keel, and install NAS623-2-10 screws to mount the shaft to the frame.



Landing Gear Repair Guide

Discrepancy: Steering yoke binding

If the steering yoke binds against the strut cap in flight the bushing may be worn. Binding can affect rudder rigging enough to hold the slip/skid ball out to the left in climb. If the pilot reports a “kick” or small movement of the rudder pedals during gear retraction, check the steering eye and/or steering yoke for binding.

- (1) Remove the steering yoke from the strut cap.
- (2) Support the yoke in a bench vice.
- (3) Break off the pressed-in grease fitting (P/N 1736).
- (4) Use a pin punch to drive the remaining section of the zerk through the bushing.
- (5) Use a new bushing to push out the old bushing, then install the new bushing.
- (6) Drill a grease port in the bushing and press in new grease fitting. Install the yoke with grease fitting down to prevent interference when the gear is in transit.

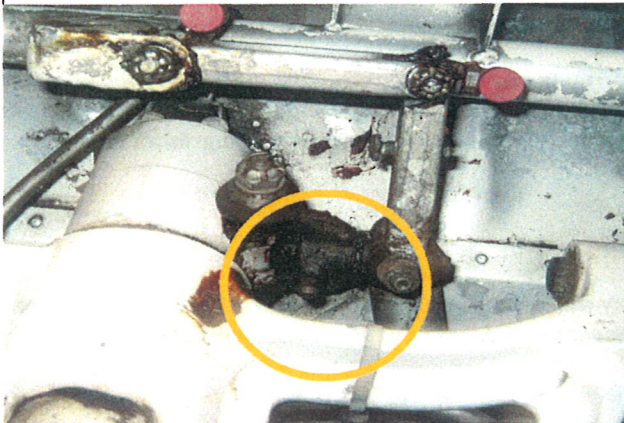

(above) Properly installed grease zerk, pointed down.

(below): Improperly installed grease zerk, pointed up.

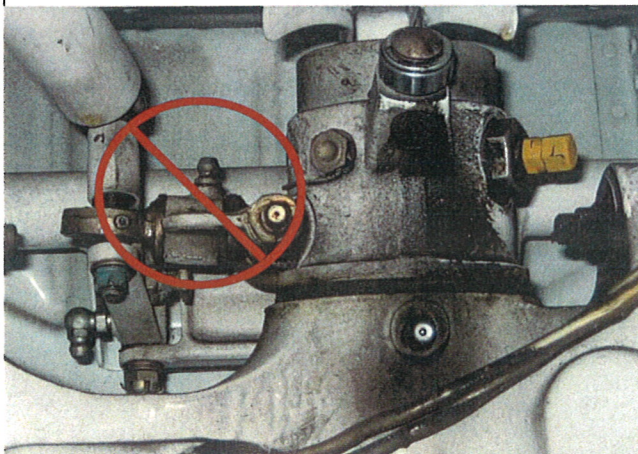

- (7) Tighten the yoke attach bolt to the strut cap until the steering stop rotates with a firm grip of the fingers, and the yoke moves freely up and down.

Discrepancy: Steering eye bearing worn

LS4 bearings can be replaced on steering eyes with grease fitting installed.

- (1) Press out the LS4 bearing.
- (2) Press in a new bearing, being careful not to apply pressure on the ball that would dislodge the ball retainer.



American Bonanza Society Air Safety Foundation

Landing Gear Repair Guide

Checklist Step 18: Check Landing Gear Gearbox

Observe the gearbox during landing gear operation, listening to the sound. Watch the top half of the gearbox for movement when a cycle begins in either direction. Occasionally this happens when a gear box sector gear has hit the internal stop in the past, and was adjusted off the stop. The split line seal may have been broken allowing the shift.

Discrepancy: Oil leaking around circumference of the gearbox

- (1) If you determine oil is leaking through the seal between the gearbox halves, remove the gearbox for re-seal and service.
- (2) Replace all the seals and bearings in the process.
- (3) Note: In the Maintenance Manual, the landing gear gearbox overhaul instructions says to install a silk thread halfway around the housing split line. In practice this will leak. Instead, install the thread all the way around to provide a complete seal of the housing split line.

Discrepancy: Landing gear handcrank does not solidly engage

If the handcrank becomes engaged and hits something solid during an electrical gear operation, a lug on the end of the gearbox worm drive gear will crack or break, making it difficult to keep the handcrank engaged during emergency extension. A handcrank that has a twist or bend should be removed to inspect the end of the worm gear for damage.

Discrepancy: Worm drive gear end play

When the aircraft is on jacks and the landing gear is part way down, move nose gear fore and aft while watching main gear for movement. The main gear should not move, but inboard gear doors will. If the main gear also moves:

- (1) Remove the oil service plug on the top of the gearbox.
- (2) With the landing gear 20 handcrank turns from the down position, have someone move a main landing gear strut left to right while you watch the worm drive gear through the service port.
- (3) Check end play – there should be no fore or aft movement. If movement is observed:
- (4) Remove the emergency hand crank assembly. Use an absorbent towel under the under the assembly, as some gearbox lube will leak out during the process.
- (5) Tighten the thrust bearing retainer nut with a spanner wrench and restake the housing.
- (6) NOTE: On very early gear boxes, end play is controlled by shims and the bearing is held in place with a snap ring.
- (7) Reinstall and safety the hand crank assembly.



American Bonanza Society Air Safety Foundation

Landing Gear Repair Guide

Discrepancy: Gear operation is slow and/or inner gear doors do not fully close at the end of the down cycle

Investigate all electrical possibilities before adjusting or re-rigging the gear doors.

- (1) Remove the landing gear motor from gearbox to inspect both brushes for length and wear.
- (2) Brushes have an average service life of about 500 cycles. Brushes worn to 5/16" length should not be left in service because many times the motor will start presenting problems prior to the next 100 hour or annual inspection. The minimum brush length varies by motor manufacturer but has been reached when a motor starts coasting or not operating when selected. Experience shows that motor-related problems will begin when the brushes are short.
- (3) Check commutator wear and that the brush holder is square with the commutator when a brush is removed for inspection.
- (4) When brushes are removed, check the wear pattern. Even if the brush length is good, the distance from the brush holder to a worn commutator may allow the brush to shift when the motor is changing direction. Without full contact, premature failure is likely. In this situation you will see wear marks on the side of the brush and the face will not make full contact.
- (5) With a slow or coasting motor, often the brush retaining screw is not tight against the brush contact, causing a poor electrical connection. This is more of an issue on the phenolic (Electromech motors) screws than the brass screws on the Lamb motors. The phenolic screw threads wear and the safety-wire hole in the brush holder will not align with brush retaining screw. Often the screw is found backed off for safety alignment and not applying good connection of the brush contact to the brush holder. In this situation a new hole must be drilled for the safety wire.
- (6) Occasionally a slow-operating or coasting landing gear motor has a soft brush installed (a flap motor brush). The flap motor brush is darker in color compared to the correct brush's copper cast. If you find this, the motor needs to be cleaned inside because the soft brush material becomes impacted inside the unit.
- (7) After inspection, reinstall each brush in the same holder from which it was removed, in exactly the same orientation. Ensure the brush retaining cap screw is tight for a good connection. Recheck dynamic breaking action.
- (8) Brush replacement in the field is not recommended, because in most situations the installer does not have the necessary equipment to seat the brushes properly.

Checklist Step 19: Lubrication

If the aircraft is going to be washed after inspection and repairs, lubricate all the areas requiring light oil and LPS 2, 3 lubes *after* the aircraft is cleaned.

Checklist Step 20: Intentionally left blank

Checklist Step 21: Intentionally left blank



American Bonanza Society Air Safety Foundation

Landing Gear Repair Guide

Checklist Step 22: Retract Landing Gear Electrically

Check the main gear lift leg-to-wing clearance .060 Min. Adjusting the clearance to the minimum dimension keeps the main gear from rubbing on the inboard gear doors. This clearance needs to be checked and adjusted first. Shortening the retract rod to accomplish this will reduce the down tension.

Discrepancy: Landing gear is rubbing on the inner gear door

- (1) Turn in main landing gear up stop bolt to clear the strut.
- (2) Pull the landing gear motor circuit breaker.
- (3) Crank the landing gear down 20 or more turns.
- (4) Shorten the retract rod end in $\frac{1}{2}$ turn at a time to raise the gear into the gear well until the desired clearance is reached.
- (5) Bump the gear up electrically after each adjustment to watch that the knee does not dimple the upper wing skin.
- (6) Recheck Down lock tension after adjusting the retract rod. Shortening the rod to raise the landing gear in the well will reduce the down lock tension.

Checklist Step 23: Uplock Cable Tension

Check and adjust the uplock cable tension per instructions the applicable Maintenance or Shop Manual.

Checklist Step 24: Main Gear Up stop Bolt

Discrepancy: Main gear up stop bolt out of adjustment

- (1) Adjust the main gear up stop bolt to .003, remove the feeler gage, turn the bolt out an additional $\frac{3}{4}$ turn, and tighten jamb nut.
- (2) Check the up lock clearance .010 to .020 between the roller and the up stop. Closer to .020 is preferred. Adjust per the applicable Maintenance or Shop Manual.

Checklist Step 25: Check Nose Gear Up Tension

Up tension needs to be adjusted prior to making down tension adjustments. With the doors disconnected (in later revisions of the Beech maintenance manuals, with nose gear doors connected), it should take a force of 20 lbs minimum to pull the strut .012" off the bumper.

Discrepancy: Nose gear up tension is low

Visually check the strut is resting on the bumper. If the nose gear door rods are adjusted short, the gear will require less tension to pull it off the bumper. Nose gear doors rattling or not up tight to the fuselage may indicate low nose gear up tension.



American Bonanza Society Air Safety Foundation

Landing Gear Repair Guide

Checklist Step 26: Check the Free Play (internal clearance) in the up side of the gearbox.

If internal clearance is closer than $\frac{1}{4}$ to $\frac{3}{4}$ turn of the manual handcrank, or nearly a full turn or more (depending on the type of gearbox that is installed), check the condition of the dynamic braking action (no coasting) with external power connected *before* adjusting travel in the gearbox.

Discrepancy: Gear stops before reaching specified extension

- (1) The limit switch is probably out of adjustment.
- (2) Bend the limit switch activating tabs or adjust the limit switch activating screw to set the gearbox internal travel to specifications in the applicable Maintenance or Shop Manual.

Discrepancy: Dynamic braking coasting

It is very difficult to determine if coasting is a result of a bad motor or a bad relay. The best and quickest method of checking is to slave in a landing gear motor you know to be good. If the system operates normally, then the old motor is the problem. Repair or replace the motor.

- (1) Check the landing gear motor brush seating.
- (2) Check that the brush retaining screw is tight against the brush plate, making good contact with brush holder.
- (3) Test the dynamic brake function.
- (4) If there is no change, check the connections at dynamic relay and the limit switch on the left side of the gearbox.
- (5) Re-test the dynamic brake function.

Discrepancy: Landing gear inboard door hangs open on landing, but checks normal with the aircraft on jacks with external power

- (1) Check the buss voltage for full power.
- (2) If the buss voltage checks good, check the landing gear motor for high field resistance. Motor power is probably low under an air load. In this case, remove the landing gear motor for overhaul.

Checklist Step 27: Check Landing Gear Warning Horn Function

Discrepancy: Landing gear warning does not sound in flight but tests good on the ground

Check the condition of throttle cable slider tubes at the throttle body for wear. Cables wear and can flex in the tubes, making gear-up horn and indicator function intermittent.

For models equipped with throttle cable-mounted warning switch, repair in accordance with the applicable Maintenance or Shop Manual.



American Bonanza Society Air Safety Foundation

Landing Gear Repair Guide

Checklist Step 28: Check Manual Extension Function

Discrepancy: Manual handcrank slips during extension

- (1) Remove handcrank assembly .
- (2) Inspect end of worm drive gear.
- (3) Overhaul or replace as necessary.

Checklist Step 29: Intentionally left blank

Checklist Step 30: Intentionally left blank

Checklist Step 31: Check Brakes and Wheels

Almost all Beech airplanes now have Cleveland brakes, either as original equipment or installed under an STC. Parts cost for earlier brake systems is now so great that it is usually less expensive to convert the airplane to Cleveland brakes than it is to make repairs.

Discrepancy: Disc outboard surface is not in alignment with the outboard edges of the torque plate bushings

- (1) Check that the axle wheel spacers are correct. This is not normally a problem except on an aircraft with a Cleveland conversion installed.
- (2) Check the brake disc part number. Discs look the same but there are some height variations. Occasionally an incorrect disk is installed. Wear marks will form on the inboard side of the landing gear strut. If worn, replace the disk.

Discrepancy: Brake disc is corroded, cracked or worn

- (1) Remove the corrosion if possible.
- (2) Replace the disc as necessary.

Discrepancy: Brake disc measures below minimum thickness

- (1) Replace the disc.
- (2) If the brake disc is a Cleveland unit and the disc part number is not known, check the installation STC or logbook entry for kit installation number.
- (3) Call Cleveland customer service (800-272-5464) for the minimum thickness for that part number. Minimum thickness may also be found at www.parker.com, then "Division Brand" then "Aircraft Wheel & Brake Maintenance Manual." The entire manual is downloadable from www.parker.com.



Landing Gear Repair Guide

Discrepancy: Fluid leakage at brake cylinder piston

- (1) Pull the parking brake handle to block fluid flow. This traps the fluid.
- (2) Remove the brake line at the cylinder and plug the line with AN 806-4D plug.
- (3) Remove the brake pistons.
- (4) Clean the brakes and pistons with low-pressure shop air.
- (5) Address any corrosion pitting in bore.
- (6) Install new O-rings.
- (7) Install an AN929-4 cap on the cylinder line fitting.
- (8) Pump new fluid into piston bores until they are ½ full.
- (9) Gently install the lower piston until the fluid level starts to rise in the top piston bore.
- (10) Install the top piston until its O-ring is in the cylinder.
- (11) Stand the cylinder upright, loosen the cap, then press in the top piston until all air is forced out of the cylinder. Tighten the cap.
- (12) Install the brake cylinder-to-aircraft line. Before tightening the line, force a small amount of fluid out of the connection and tighten the fitting.
- (13) Install the brake pressure plate and hand spring clamp.
- (14) Release the parking brake valve.
- (15) Compress the pistons into the cylinder.
- (16) Reattach the brake assembly to the landing gear.
- (17) Apply brakes to check their operation. In most cases brake bleeding will not be required.

Discrepancy: Brake hoses require replacement and/or installation

Cleveland brake conversions use existing hoses and original fittings on the main landing gear. The existing hose routing bends are smaller than what FAR 43.13 allows for #4 hose when the aircraft is sitting on the ground. Struts have gone flat on landing and broken the hose fitting on the cylinder, resulting in no braking action on the affected wheel.

Consider installing brake hose clamps (Left hand P/N 35-815264-1 and Right hand P/N 35-815264-2) on the struts, and P/N MS28741-4-160 hose. This can be done as a minor alteration to the original STC.



Landing Gear Repair Guide

Discrepancy: Brake hoses require replacement and/or installation

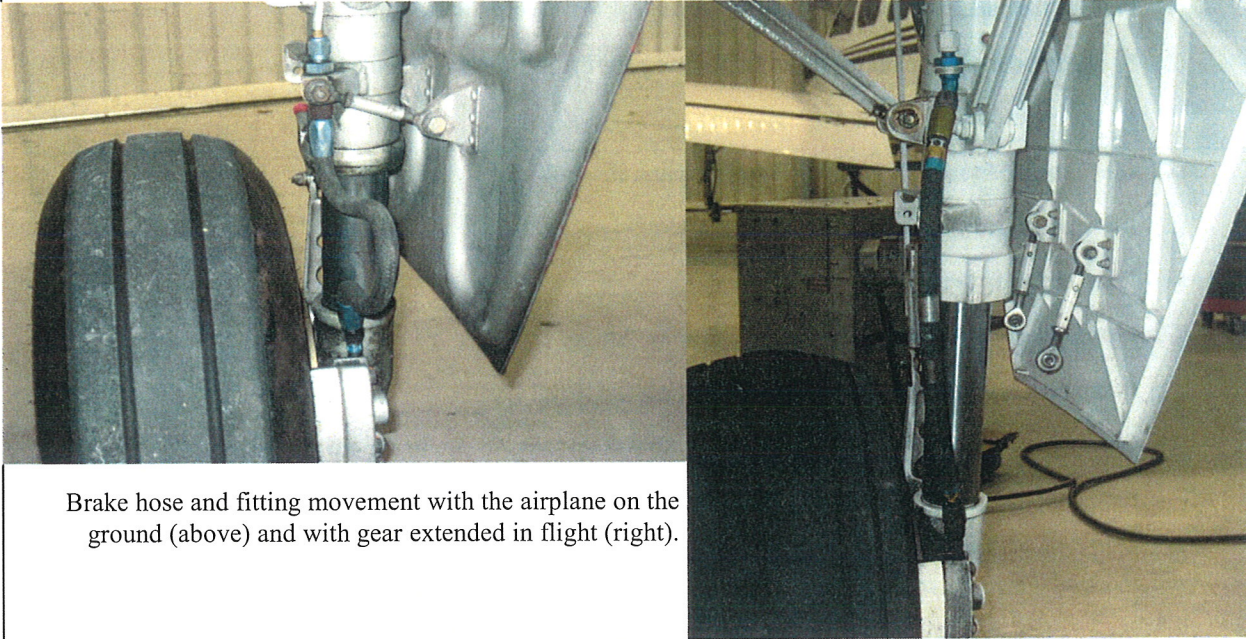

Brake hose and fitting movement with the airplane on the ground (above) and with gear extended in flight (right).

Checklist Step 32: Intentionally left blank

Checklist Step 33: Check brake fluid reservoir level

Apply the brakes before checking the reservoir to get an accurate fluid level check. Inspection steps compressing the piston will fill the can.

Checklist Step 34: Shimmy Damper

Service and overhaul the shimmy damper per instructions in the applicable Maintenance or Shop Manual.

- (1) Using an AN960-4 washer on the end of the spring, and an awl on the service end of the shimmy damper shaft to compress the spring below the cotter pin hole, greatly assists final assembly of the unit. Use the awl to open up the center of the cotter pin to be able to check the shimmy damper fluid level.
- (2) Before installing the shimmy damper after overhaul or service, put a few drops of hydraulic fluid in the clevis end of the rod, rotate the rod to coat the surface as a corrosion inhibitor. A majority of rods replaced are rejected because of corrosion in the forward end of the tube.
- (3) After installing the shimmy damper, check the nose gear steering rigging per instructions in the applicable Maintenance or Shop Manual.



American Bonanza Society Air Safety Foundation

Landing Gear Repair Guide

Checklist Step 35: Check Landing Gear Struts

Discrepancy: Strut extension is low

- (1) Service the strut with nitrogen.
- (2) There are no factory criteria for how much nitrogen to put in the struts except for the strut extension that results. On the main gear the bottom of the outboard gear door should be aligned with the center line of the main gear lower torque knee pin. The nose strut should be extended the width of the palm of the hand.

Discrepancy: Strut fluid is leaking

1. If a strut is bouncy it is low on oil and the strut is riding on a column of air. Servicing the strut with hydraulic fluid may require resealing.
2. A strut that has not been serviced with fluid in a long time has a good possibility of leaking during the process. When the air load is removed from the O-ring and the strut is moved full travel to service it with fluid, foreign material may lodge in the O-ring area. When a nitrogen charge is applied the strut may develop a leak at the center seal.
3. A strut may show signs of leakage in the area of the Huck bolt on the side of the strut. Fluid leakage in this area indicates that the O-ring on the outer diameter of the center bearing is leaking. Removal and reinstallation of this bearing requires special tooling. This usually means sending strut to a repair station to be rebuilt.

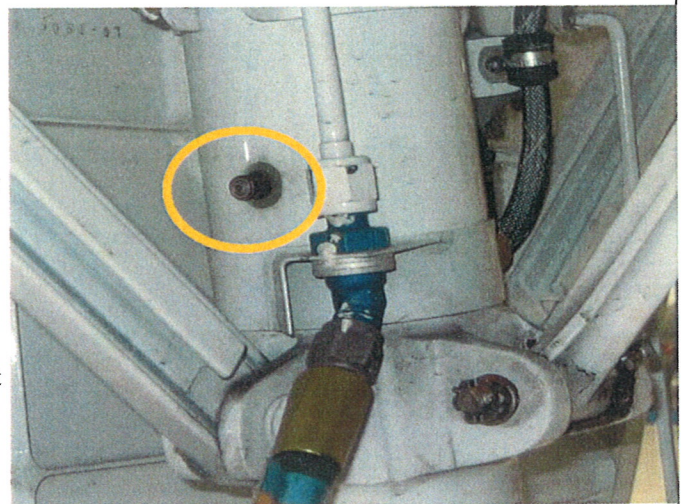

Gear strut Huck bolt

