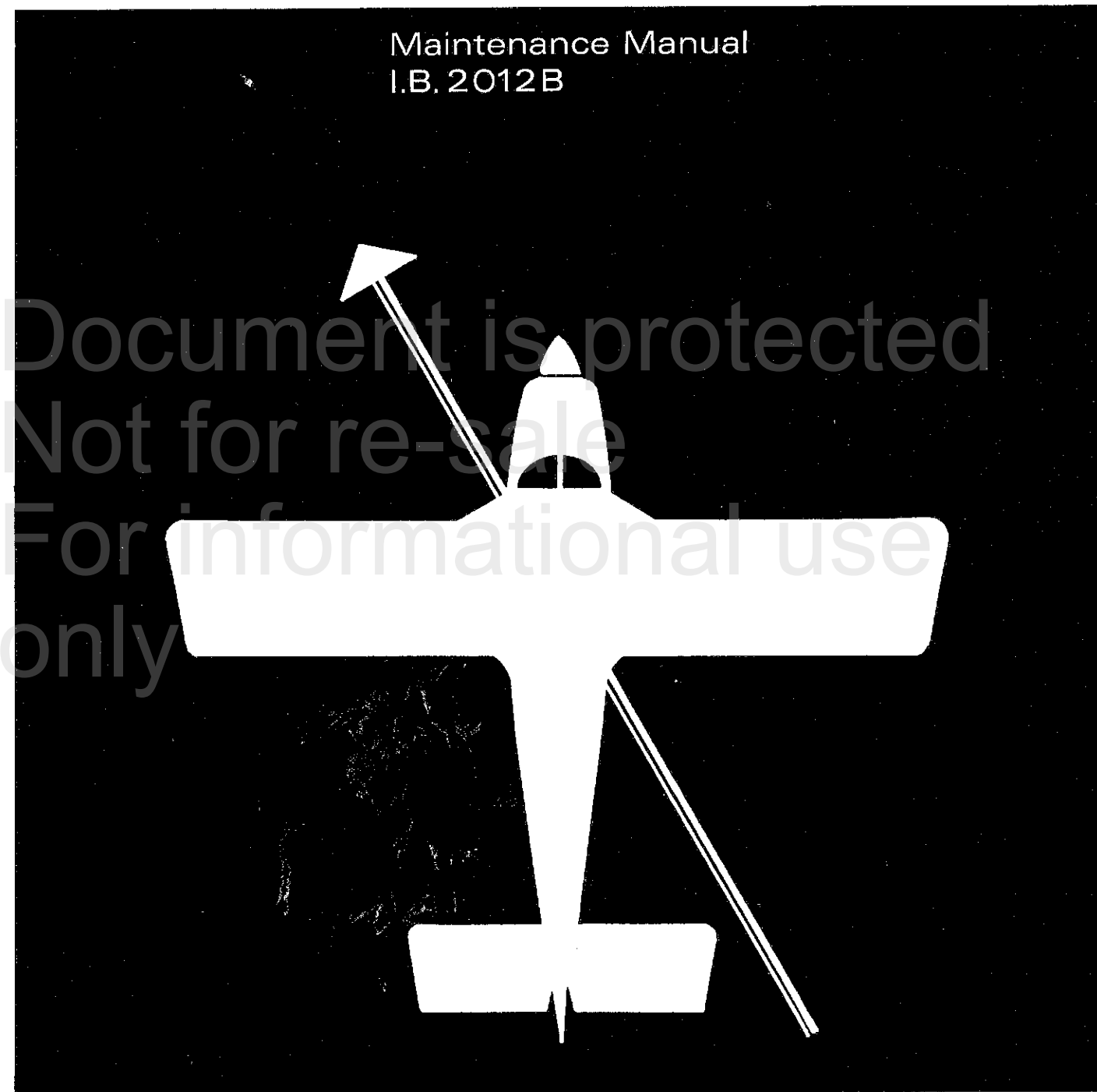


ADF-T12D Automatic Direction Finder System

Maintenance Manual
I.B. 2012B



**Avionics
Division**

Maintenance Manual

I.B. 2012B

ADF-T12D
Automatic Direction
Finder System

Document is protected
Not for re-sale
For informational use
only

WARNING

This manual which you have requested is furnished for general information purposes only. Service bulletins which supplement this manual are only furnished to Bendix authorized FAA approved repair stations. DO NOT USE THIS MANUAL FOR EFFECTUATING REPAIRS OF THE EQUIPMENT.

Bendix Avionics Division

LIST OF EFFECTIVE PAGES

TITLE PAGE/ PROPRIETARY PAGE					
NUMBERED PAGES	EFFECTIVE DATE	NUMBERED PAGES	EFFECTIVE DATE	NUMBERED PAGES	EFFECTIVE DATE
i/ii	Aug/75	4-5/4-7	Aug/71	6-19b/6-20b 6-21/6-24	Aug/75
iii	Dec/72	4-8/4-8b	Dec/72		Aug/71
iv	Aug/71	4-9	Aug/71		
v	Dec/72	4-10	Mar/72		
vi	Aug/71	4-11/4-13	Aug/71		
vii	Dec/72	4-14	Mar/72		
viii	Aug/75	4-15/4-18	Dec/72		
ix/x	Aug/71	4-19	Aug/71		
1-1	Aug/71	4-20/4-27	Dec/72		
1-2	Mar/72	5-1/5-2	Mar/72		
1-3	Aug/71	5-3/5-6	Dec/72		
1-4	Mar/72	5-7/5-12	Aug/75		
1-5	Oct/73	5-13	Oct/73		
1-6	Aug/71	5-14	Dec/72		
1-7/1-8	Mar/72	5-15/5-16	Mar/72		
1-9/1-14	Aug/71	5-17	Oct/73		
1-15/1-16	Dec/72	5-18/5-22	Mar/72		
1-17/1-22	Aug/71	5-23/5-25	Oct/73		
2-1	Mar/72	5-26/5-27	Aug/75		
2-2/2-5	Aug/71	5-28	Oct/73		
2-6	Mar/72	5-29/5-34	Aug/75		
2-7/2-8	Aug/71	6-1/6-2	Aug/71		
2-9/2-16f	Dec/72	6-3/6-4	Dec/72		
2-17	Aug/75	6-4a/6-4b	Aug/75		
2-18/2-22	Aug/71	6-5/6-6	Dec/72		
3-1/3-2	Aug/71	6-5a/6-6a	Dec/72		
3-3	Aug/75	6-5b/6-6b	Aug/75		
3-4	Aug/75	6-7/6-8	Oct/73		
3-5/3-7	Mar/72	6-7a/6-8a	Dec/72		
3-8/3-9	Aug/71	6-7b/6-8b	Dec/72		
3-10/3-11	Oct/73	6-7c/6-8c	Oct/73		
3-12	Dec/72	6-9/6-10	Aug/75		
3-13/3-14b	Aug/75	6-11/6-12	Aug/71		
3-15	Aug/75	6-11a/6-12a	Aug/75		
3-16	Dec/72	6-13/6-14	Aug/75		
3-17	Mar/72	6-13a/6-14a	Dec/72		
3-18/3-20	Aug/71	6-13b/6-14b	Aug/75		
4-1	Aug/71	6-15/6-16	Aug/75		
4-2	Aug/75	6-17/6-18	Dec/72		
4-2a/4-2b	Mar/72	6-17a/6-18a	Aug/75		
4-3	Aug/71	6-19/6-20	Aug/75		
4-4	Mar/72	6-19a/6-20a	Dec/72		

SERVICE BULLETINS

The following list of service bulletins apply to the equipment covered in this manual. Copies of these bulletins are available upon request to:

The Bendix Corporation
Avionics Division, Service Dept.
Post Office Box 9414
Fort Lauderdale, Florida 33310

SERVICE BULLETIN NUMBER	DATE OF ISSUE	EQUIPMENT TYPE	PURPOSE OF BULLETIN
201F-01 (T12-006)	Aug/71	201F	Modification No. 1: Improves clock low temperature performance.
201F-02 (T12-007)	Oct/71	201F	Modification No. 2: Eliminates excess ripple on tuning bus that could cause poor sensitivity at the low end of Band III.
551()-01-1 (T12-008-1)	Jan/72	551()	Modification No. 1: New drive motor replaces old motor which is no longer available.
201F-03 (T12-009)	Jun/72	201F	Modification No. 3: Stabilizes tuning bus voltage.
201F-04 (T12-011)	Jun/73	201F	Modification No. 4: Reduces low level audio distortion.
201F-05 (T12-013)	Sep/73	201F	Modification No. 5: Improvement of bearing indication.
201F-06 (T12-014)	Sep/74	201F	Modification No. 7: Reduction of bearing pointer hunting.
551()-02 (T12-015)	Oct/74	551()	Modification No. 3: Increased indicator sensitivity adjustment range.
551()-03 (T12-016)	Oct/74	551()	Modification No. 4: Improved high ambient temperature operation.
201F-07 (T12-017)	Aug/75	201F	Modification No. 6: Transient protection for VVC diodes.

TABLE OF CONTENTS

SECTION I DESCRIPTION AND OPERATION

<u>Paragraph</u>		Page
1-1.	General -----	1-1
1-2.	Description of Components -----	1-1
1-3.	Outline Dimensions and Weights -----	1-4
1-4.	Transistor and Integrated Circuit Complement -----	1-4
1-5.	Technical Characteristics -----	1-6
1-6.	Operating Controls and Their Functions -----	1-7
1-7.	Principles of Operation -----	1-10
1-8.	Phase Relationships -----	1-16
1-9.	Receiver (REC) Operation -----	1-20

SECTION II DETAILED CIRCUIT DESCRIPTION

2-1.	Loop R-F Amplifier -----	2-1
2-2.	Sense R-F Amplifier -----	2-1
2-3.	Balanced Modulator -----	2-2
2-4.	Mixer -----	2-5
2-5.	Voltage Controlled Oscillator (VCO) -----	2-5
2-6.	I-F Amplifiers and Detector -----	2-6
2-7.	AGC Detector and Amplifier -----	2-7
2-8.	Audio Amplifier -----	2-7
2-9.	Synthesizer -----	2-9
2-10.	Programmable Counter -----	2-10
2-11.	1.000 kHz Crystal Controlled Clock -----	2-15
2-12.	Phase Detector -----	2-16
2-13.	Frequency Selection -----	2-16b
2-14.	Digital Frequency Selectors -----	2-16d
2-14a.	Offset Data Selection Circuitry -----	2-16d
2-15.	Monitor (MON) -----	2-16f
2-16.	Beat Frequency Oscillator (BFO) -----	2-17
2-17.	5 Volt D-C Regulator -----	2-17
2-18.	Motor Control Amplifier -----	2-18

TABLE OF CONTENTS

SECTION III
MAINTENANCE PRACTICES

<u>Paragraph</u>	<u>Page</u>
3-1. General -----	3-1
3-2. Adjustment and Test -----	3-1
3-2. A. Job/Use -----	3-1
3-2. B. Test Equipment Required -----	3-1
3-2. C. Screen Room -----	3-2
3-2. D. Standard Test Antenna -----	3-2
3-2. E. Receiver Alignment -----	3-6
3-2. E. (1) I-F Alignment -----	3-6
3-2. E. (2) VCO Alignment -----	3-7
3-2. E. (3) R-F Alignment -----	3-8
3-2. E. (4) Loop Stage Alignment -----	3-9
3-2. E. (5) AGC Adjustment -----	3-10
3-2. E. (6) Audio Level Adjustment -----	3-10
3-2. E. (7) AGC Performance Check -----	3-11
3-2. F. R-F Resolver Alignment -----	3-11
3-2. F. (1) Alignment Procedures -----	3-11
3-2. G. Servo Amplifier-Indicator Alignment -----	3-13
3-2. G. (1) Amplifier Gain Test -----	3-13
3-2. G. (2) Indicator Rotation Speed -----	3-13
3-2. G. (3) Switching Voltage Test -----	3-15
3-2. H. Receiver Tests -----	3-15
3-2. H. (1) Receiver Sensitivity (MCW) -----	3-15
3-2. H. (2) Receiver Sensitivity (CW) -----	3-16
3-2. H. (3) Receiver Selectivity -----	3-16
3-2. H. (4) ADF Sensitivity -----	3-17
3-2. H. (5) Bearing Error and Speed of Rotation -----	3-17
3-2. H. (6) Frequency Accuracy -----	3-18
3-2. H. (7) Synthesizer Operational Check -----	3-18
3-2. I. Audio Amplifier Tests -----	3-20
3-2. I. (1) Audio Gain -----	3-20
3-2. I. (2) Maximum Power Output -----	3-20

TABLE OF CONTENTS

SECTION III
MAINTENANCE PRACTICES

<u>Paragraph</u>		<u>Page</u>
3-2. I. (3)	Frequency Response -----	3-20

SECTION IV
TROUBLESHOOTING

4-1.	General -----	4-1
4-2.	Transistor and Integrated Circuits Testing Methods -----	4-1
4-2. A.	Signal Tracing -----	4-1
4-2. B.	D-C Voltage Measurements -----	4-1
4-2. C.	Transistor and Integrated Circuit Testing -----	4-2
4-2. D.	Varicap Diodes -----	4-2
4-2. E.	Troubleshooting Tables -----	4-2
4-2. F.	Troubleshooting Marginal Performance -----	4-5
4-2. G.	Synthesizer and Frequency Selector Operational Check. -----	4-12
4-3.	Lubrication -----	4-15
4-3. A.	Servo Amplifier Indicator -----	4-15
4-4.	201F ADF Receiver Disassembly Procedure -----	4-15
4-5.	201F ADF Receiver Assembly Procedure -----	4-18
4-6.	551A Servo Amplifier-Indicator Disassembly Procedure -----	4-21
4-7.	551B Remote Servo Amplifier Disassembly Procedure -----	4-22
4-8.	551C Dual Synchro Indicator Disassembly Procedure -----	4-23
4-9.	551E Servo Amplifier - Indicator Disassembly Procedure -----	4-24
4-10.	551RL Servo Amplifier - Indicator Disassembly Procedure -----	4-26
4-11.	Servo Amplifier - Indicator Assembly Procedure -----	4-27

SECTION V
PARTS LIST

5-1.	General -----	5-1
	201F ADF Receiver, Mechanical -----	5-3
	201F ADF Receiver, Electrical -----	5-7
	551A Servo Amplifier-Indicator, Mechanical -----	5-16
	551B Remote Servo Amplifier, Mechanical -----	5-18
	551C Dual Synchro Indicator, Mechanical -----	5-20

TABLE OF CONTENTS

SECTION V
PARTS LISTS

<u>Paragraph</u>		<u>Page</u>
	551E Servo Amplifier-Indicator, Mechanical -----	5-22
	551RL Servo Amplifier-Indicator, Mechanical -----	5-23
	Servo Amplifier-Indicator Chassis, Electrical -----	5-25
	102A and 102B Audio Amplifiers, Electrical -----	5-27

SECTION VI
SCHEMATIC DIAGRAMS

6-1.	General -----	6-1
------	---------------	-----

Document is protected
Not for re-sale
For informational use
only

LIST OF FIGURES

<u>Figure</u>		<u>Page</u>
1-1	ADF-T12D System Components -----	x
1-2	ADF Operation Simplified Pictoral Diagram -----	1-9
1-3	ADF-T12D System Block Diagram -----	1-17
1-4	Phase Relationships -----	1-19
2-1	Balanced Modulator (Condition 1) Simplified Schematic -----	2-3
2-2	Balanced Modulator (Condition 2) Simplified Schematic -----	2-4
2-3	Simplified Tuning Logic -----	2-10
2-3a	Two-Stage Programmable Decade-Counter, Simplified Schematic Diagram -----	2-11
2-3b	Timing Diagram of Two-Stage Programmable Decade-Counter -----	2-12
2-4	Programmable Counter Block Diagram -----	2-14
2-5	Logic Truth Tables -----	2-14
2-6	Tuning Voltage Integration Circuit, Simplified Schematic Diagram ---	2-16a
2-6a	Frequency Selector, Logic Truth Tables -----	2-16e
2-7	Motor Control Amplifier Operation 45° -----	2-19
2-8	Motor Control Amplifier Operation 225° -----	2-19
2-9	Motor Control Amplifier Operation 0° -----	2-22
3-1	Standard Test Sense Antenna Connection -----	3-3
3-2	201F ADF Receiver Bench Test Set-Up -----	3-4
3-3	Receiver, Bottom View -----	3-5
3-4	Receiver, Top View -----	3-5
3-5	Loop Alignment -----	3-9
3-6	Modulation Percentages -----	3-12
3-7	Resolver Alignment Set-Up -----	3-12
3-8	Servo Amplifier-Indicator Bench Test Set-Up -----	3-14a
3-9	Audio Amplifier Bench Test Set-Up -----	3-20
4-1	201F ADF Receiver Disassembly and Assembly Guide -----	4-14
5-1	201F ADF Receiver Assembly -----	5-2
5-2	201F ADF Receiver P.C. Boards -----	5-5
5-3	551A Servo Amplifier-Indicator, Exploded View -----	5-15
5-4	551B Remote Servo Amplifier, Exploded View -----	5-17
5-5	551C Dual Synchro Indicator, Exploded View -----	5-19

LIST OF FIGURES

Figure	Page
5-6 551E Servo Amplifier-Indicator, Exploded View -----	5-21
5-7 Servo Amplifier-Indicator Chassis -----	5-24
6-1 201F ADF Receiver, Schematic Diagram -----	6-3
6-2 201F ADF Receiver, Wiring Diagram -----	6-9
6-3 551A/551B Servo Amplifier-Indicator, Schematic Diagram -----	6-13
6-4 Not Used	
6-5 551E Servo Amplifier-Indicator, Schematic Diagram -----	6-15
6-6 551RL Servo Amplifier-Indicator, Schematic Diagram -----	6-19
6-7 551C Dual Synchro Indicator, Schematic Diagram -----	6-21
6-8 2321E Loop Antenna, Schematic Diagram -----	6-21
6-9 102A Audio Amplifier, Schematic Diagram -----	6-22
6-10 102B Audio Amplifier, Schematic Diagram -----	6-22
6-11 551() Indicator (Connector Field Modification), Wiring Diagram -----	6-23

LIST OF TABLES

<u>Table</u>	<u>Page</u>
3-1 Test Equipment Required -----	3-1
3-2 Receiver Sensitivity (MCW) -----	3-15
3-3 Receiver Sensitivity ADF -----	3-17
3-4 Receiver, Synthesizer Check -----	3-19
4-1 System Troubleshooting -----	4-3
4-2 Installation Check -----	4-5
4-3 ADF Receiver Conditions -----	4-7
4-4 Servo Amplifier-Indicator Conditions For Units With Old Type Motor ----	4-8
4-4A Servo Amplifier - Indicator Conditions For Units With New Type Motor ---	4-8a
4-5 Receiver Synthesizer Troubleshooting -----	4-9
4-6 Synthesizer and Frequency Selector Operational Check -----	4-13

BENDIX AVIONICS EQUIPMENT MODIFICATION SYSTEM

The system employed by Bendix Avionics to identify changes to the equipment covered by this instruction manual is intended to provide a positive yet flexible means for identifying, marking, and documenting changes made to the equipment.

Documentation

Every change which alters the equipment, and therefore would be of interest to the user, is identified and documented. These changes are defined by Bendix Avionics as "production changes" and are documented by periodic revisions to this manual. These changes are summarized on the "Summary of Changes To" page which precedes each schematic diagram. This summary provides a complete change history by serial number of the equipment since initial production.

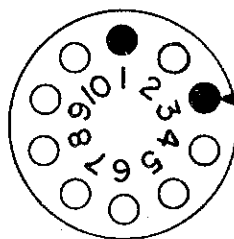
Identification

If a Service Bulletin is issued covering a "production change", the above applies and, in addition, a red dot of paint will appear on the numbered modifications decal located on the outside of the equipment. Production changes for which Service Bulletins are issued are defined as "Modifications". The modification decal serves only to identify, by number, which Service Bulletins have been incorporated into the equipment. A list of Service Bulletins appears on page ii of this manual.

Example:



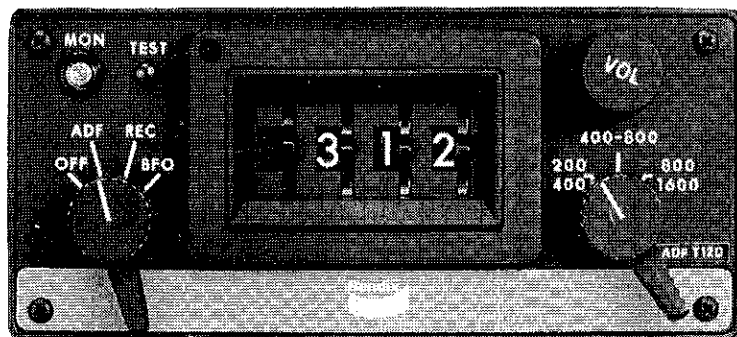
Actual
Size



Service Bulletins #1 and #3 have been incorporated in this equipment.

Whether a production change warrants a Service Bulletin, and thus becomes a modification, is a decision made by Bendix Avionics engineering and service departments when considering all aspects of the change and its benefit to the customers.

ADF-T12D AUTOMATIC DIRECTION FINDER SYSTEM



Model 201F
ADF Receiver



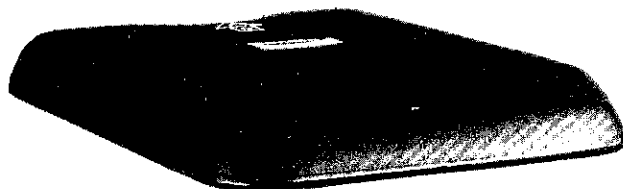
Model 551RL
Servo Amplifier-Indicator



Model 551C
Dual Synchro Indicator



Model 551A/E
Servo Amplifier-Indicator



Model 2321E
Fixed Loop Antenna

ADF-T12D System Components
Figure 1-1

SECTION I
DESCRIPTION AND OPERATION

1-1. GENERAL

- A. This manual contains maintenance, and overhaul instructions for the ADF-T12D Automatic Direction Finder System. The manual contains sections on Description and Operation, Detailed Circuit Description, Maintenance Practices, Troubleshooting, Parts Lists and Schematics.
- B. The ADF-T12D System functions as an airborne automatic direction finder or as a range and broadcast band receiver. Three tuning bands provide frequency coverage in 1 kHz steps from 200 to 1600 kHz. During ADF mode of operation, the system may be used to either home on a station or to obtain a position fix. Directional information is displayed on a panel-mounted indicator.
- C. The system comprises three principal components (See Figure 1-1). They are as follows:
 - (1) Model 201F ADF Receiver
 - (2) Model 551A Servo Amplifier-Indicator, Model 551B Remote Servo Amplifier Model 551C Dual Synchro Indicator, Model 551E Servo Amplifier-Indicator and Model 551RL Servo Amplifier Indicator.
 - (3) Model 2321E Fixed Loop Antenna.
- D. A speaker amplifier is available as optional equipment. The amplifier (Model 102A or B) is mounted separately at a convenient location in the aircraft.

1-2. DESCRIPTION OF COMPONENTS

- A. 201F ADF Receiver
 - (1) The receiver contains all the circuitry for radio reception and provides an output to the servo amplifier-indicator unit which provides servo motor control of the resolver rotor coil. The unit is completely transistorized. Essentially, the chassis is divided into three sections; the r-f stages in form of removable modules are mounted in section one. The i-f, audio, 2nd detector and agc stages in section two and the synthesizer in section three.
 - (2) The receiver dust cover mounts in the aircraft instrument panel. The connector mounting bracket at the rear left-hand side of the dust cover supports a 16-pin connector receptacle for the main cable assembly and a coaxial connector for the sense antenna. The complete receiver assembly slides into the dust cover. The 16-pin connector at the rear of the receiver mates with the 16-pin receptacle in the dust cover. The receiver secures to the dust cover by means of a retaining cam. By rotating the retaining screw on the front of the panel, the cam attains an upright position and extends through the slot at the top of the cover. All operating controls for the system are located on the front panel of the receiver with the exception of the 14/28v selector switch, which is located at the rear of the receiver chassis.

SECTION I

DESCRIPTION AND OPERATION

1-2.A.

- (3) The receiver has three operating modes; REC, ADF and BFO. In the REC mode of operation, the unit functions as a conventional superheterodyne receiver and provides audio output to headphones or audio system. In the ADF mode of operation, two additional stages in the receiver become operative. The unit then functions, in conjunction with the model 551() Servo Amplifier-Indicator, as an automatic direction finder. During ADF mode of operation, the receiver receives the tuned-in signal from the selected transmitting station at two distinct points; one at the bidirectional fixed loop antenna and the other at the omni-directional sense antenna. The receiver combines these two signals and, after low-frequency modulation of the loop r-f signal by the output of the power oscillator in the servo amplifier-indicator, produces a low-frequency motor control output voltage. This voltage, after amplification and phase comparison in the servo amplifier, is applied to the control windings of the d-c servo motor in the servo amplifier-indicator. The servo motor (mechanically linked to the r-f resolver) drives the rotor of the resolver until the indicator pointer, also mechanically linked to the r-f resolver assumes a position such that results in zero voltage at the resolver output. This rotor position corresponds to the direction of arrival of the transmitted radio wave. In the BFO mode of operation the receiver is able to receive type A0 and A1 transmissions.

B. SERVO AMPLIFIER-INDICATOR

- (1) The Model 551A Servo Amplifier-Indicator is a compact 6-stage transistorized amplifier-power oscillator unit which houses the d-c servo motor, r-f resolver and the ADF bearing indicator. The principal function of the unit is to amplify the low-frequency motor control voltage output from the receiver and phase compare this signal with the power oscillator reference signal and apply the resultant signal to the control windings of the d-c servo motor. The d-c servo motor, mechanically linked to the r-f resolver rotates until the r-f voltage output of the resolver becomes zero. The r-f resolver, mechanically linked to the ADF bearing indicator pointer will at this time, cease to rotate. The indicator pointer will indicate the relative bearing to the aircraft to the selected station.
- (2) 551B Remote Servo Amplifier is a remote mounting unit, similar to the Model 551A Servo Amplifier Indicator except it has no self-contained indicator. The 551B contains a transmitter synchro to drive a panel mounted indicator.
- (3) Model 551C Dual Synchro Indicator incorporate dual pointers to permit the simultaneous presentation of two separate inputs.
- (4) Model 551E Servo Amplifier-Indicator provides all of the functions of the Model 551A but has an additional synchro transmitter output for operating a remotely located indicator.

SECTION I

1-2. B.

DESCRIPTION AND OPERATION

- (5) Model 551RL is similar to and interchangeable with the Model 551A. The primary difference is that the 551RL contains a rotatable Azimuth card and internal blue-white lighting.
- (6) The servo amplifier-indicator includes a low-frequency power oscillator and a filter circuit. The power oscillator provides reference voltage excitation for the balanced modulator stage in the receiver and the d-c servo motor phase comparison circuit. The filter functions to by-pass undesirable frequency components from the output of the receiver while passing the fundamental motor control frequency (47 Hz ADF signal).
- (7) The r-f resolver consists of two distributed stator windings wound inside a cylindrical form, with the two coils at right angles to each other. A secondary winding is wound on a cylindrical rotor that is free to rotate through 360 degrees in relation to the two stators.
- (8) The r-f resolver is electrically connected to the Model 2321E fixed loop antenna. The r-f resolver stator coils convert the fixed loop voltages to a resultant magnetic field. The magnetic field is induced into the r-f resolver rotor coil. The angular position of the resultant field defines the direction of arrival of the transmitted radio wave. This action produces an output voltage that is a measure of the angular displacement between the rotor position and the resultant field. This "error" voltage is applied to the loop r-f stage in the receiver.

C. FIXED LOOP ANTENNA

- (1) The Model 2321E Fixed Loop Antenna consists of two insulated coils, wound at right angles to each other on a flat ferrite core and terminated at a 7-pin socket connector. The loop is rectangular in shape and mounts externally on the aircraft. The assembly is sealed in potting compound making it impervious to extreme environmental conditions. The unit is sprayed with antistatic paint.
- (2) The wavefront of the station-transmitted radio wave intersects the lateral and longitudinal coils of the fixed loop antenna and induces voltages in each of them. In relation to the aircraft, these voltages are proportional in amplitude to the angle of arrival of the radio wave with respect to the position of the aircraft.

D. AUDIO AMPLIFIER

- (1) The Models 102A and 102B Audio Amplifiers (optional to all ADF-T12B, C and D Systems) are single stage push pull common emitter power amplifiers that operate from the headset output in the receiver. With a 3 ohm load, the Model 102A amplifier is designed for 3.5 watts output compared to the 10 watts output of the Model 102B.

SECTION I

DESCRIPTION AND OPERATION

1-2.D.

- (2) The amplifiers are so constructed as to separately mount at any convenient location in the aircraft. They connect to the main inter-connect cable by means of an 8-pin Amphenol plug.
- (3) Power requirements for Models 102A and 102B Audio Amplifier are 14 and 28 vdc respectively.

1-3. OUTLINE DIMENSIONS AND WEIGHT

- A. Outline dimensions of the ADF-T12D system may be found on the applicable outline drawings in Installation Manual I. B. 2012-1.
- B. WEIGHTS OF THE ADF-T12D SYSTEM ARE AS FOLLOWS:

- (1) Model 201F ADF Receiver 3.9 lbs.
- (2) Model 551A Servo Amplifier-Indicator 1.7 lbs.
- Model 551B Remote Servo Amplifier 2.0 lbs.
- Model 551C Dual Synchro Indicator 1.2 lbs.
- Model 551E Servo Amplifier-Indicator 2.5 lbs.
- Model 551RL Servo Amplifier-Indicator 1.7 lbs.
- (3) Model 2321E Fixed Loop Antenna 1.3 lbs.

1-4. TRANSISTOR AND INTEGRATED CIRCUIT COMPLEMENT

A. 201F ADF RECEIVER

TRANSISTORS

SCHEMATIC SYMBOL	TYPE	FUNCTION
Q1	2N1637, MPS6516	Loop R-F Amplifier
Q2	2N1637, MPS6516	Balanced Modulator
Q3	2N1637, MPS6516	Sense R-F Amplifier
Q4	2N1637, MPS6516	Mixer
Q5	NF500	Voltage Controlled Oscillator
Q6	2N1638, MPS6516	1st I-F Amplifier
Q7	2N1638, MPS6516	2nd I-F Amplifier
Q8	2N1638, MPS6516	3rd I-F Amplifier
Q9	2N1304	AGC Amplifier
Q10	2N1193	1st Audio Amplifier
Q11	SA-279	2nd Audio Amplifier
Q12	SA-279	3rd Audio Amplifier
Q13	SA-279	3rd Audio Amplifier
Q14	EL403/SPS938	Voltage Controlled Oscillator
Q15	EL403/SPS938	Voltage Controlled Oscillator
Q16	EL403/SPS938	Voltage Controlled Oscillator
Q101	EL403/SPS938	256 kHz Oscillator
Q102	EL403/SPS938	Oscillator Buffer

1-4. A.

SECTION I
DESCRIPTION AND OPERATION

TRANSISTORS

SCHEMATIC SYMBOL	TYPE	FUNCTION
Q104	EL403/SPS938	VCO Buffer
Q105	EL403/SPS938	Low Pass Amplifier
Q106	EL403/SPS938	Buffer
Q107	EL403/SPS938	Buffer
Q111	EL403/SPS938	Darlington Amplifier
Q112	2N2270	Darlington Amplifier
Q115	T1P-29	Darlington Series Pass Regulator
Q116	EL403/SPS938	Regulator Control
Q117	EL403/SPS938	Voltage Control Amplifier

INTEGRATED CIRCUITS

SCHEMATIC SYMBOL	TYPE	FUNCTION
U101	7493	+16 Counter
U102	7493	+16 Counter
U103	MC4016P	Programmable Counter
U104	MC4016P	Programmable Counter
U105	MC4016P	Programmable Counter
U106A	7474	Coincidence Detector
U106B	7474	Programmable Counter
U107A	7410	Programmable Counter
U107B	7410	Data Selection
U107C	7410	Programmable Counter
U111A	7401	Not Used
U111B	7401	Data Selection
U111C	7401	Data Selection
U111D	7401	Programmable Counter
U112A	7400	BFO Switch
U112B	7400	Not Used
U112C	7400	100 kHz 1 Bit Inverter
U112D	7400	10 kHz Carry Inverter
U113A	7451	Data Selection
U113B	7451	Data Selection
U114A	7451	Data Selection
U114B	7451	Data Selection
U115	MC4044P	Frequency/Phase Detector

SECTION I

1-4.B.

DESCRIPTION AND OPERATION

B. SERVO AMPLIFIER-INDICATOR

SCHEMATIC SYMBOL	TYPE	FUNCTION
Q1	2N1304	Low Voltage Amplifier
Q2	2N1193	1st. Audio Amplifier
Q3	2N1193	2nd. Audio Amplifier
Q4	2N1193	3rd. Audio Amplifier
Q5, Q6 (matched pair)	SA319	Motor Control Amplifier
Q7, Q8	2N1191	47 Hz Power Oscillator

1-5.

TECHNICAL CHARACTERISTICS

CHARACTERISTICS	DESCRIPTION
Frequency Range:	200-1600 kHz (All Channels Crystal Controlled)
	Band 1 200-400 kHz
	Band 2 400-800 kHz
	Band 3 800-1600 kHz
Channel Spacing	1 kHz
Tuning Accuracy	Within ± 500 Hz of indicated frequency
Tune-In Time	100 milliseconds (approx.)
Operating Modes and Type of Reception	ADF: Automatic Direction Finder (A0, A1, A2 and A3) reception. REC: MCW and Voice reception - (A2 and A3) BFO: CW reception - (A0 and A1)
Sensitivity:	
ADF	100 $\mu\text{v}/\text{m}$ for $S+N/N = 6$ db using $\frac{1}{2}$ Meter Sense Antenna.
REC	70 $\mu\text{v}/\text{m}$ for $S+N/N = 6$ db using $\frac{1}{2}$ Meter Sense Antenna.
Selectivity (Bandwidth)	4.0 kHz max. at 6 db points 12.0 kHz max. at 60 db points
ADF Bearing Accuracy	$\pm 3^\circ$ from 70 $\mu\text{v}/\text{m}$ to 0.5 v/m
Threshold Sensitivity	7 seconds maximum with indicator 175° off bearing. Input signal level = 70 $\mu\text{v}/\text{m}$

SECTION I

1-5.

DESCRIPTION AND OPERATION

CHARACTERISTICS	DESCRIPTION	
Audio Output REC	50 mw minimum capability (See note on audio level set, page 3-10) at 70 μ v/m using $\frac{1}{2}$ meter antenna.	
Audio Frequency Response	Within 9 db between 350 and 1400 Hz.	
Audio Output Impedance	500 ohms (headset) 3 ohms (Speaker) (using 102 amplifier)	
Operating Current Requirements for Single System (201F, 551A)	<u>14 VDC</u>	<u>28 VDC</u>
	800 ma	800 ma
ADF Receiver Lighting Current Requirements	320 ma	160 ma
Cooling	Convection	
Typical Weights:		
Single System (Basis)	7.4 lbs.	
Dual System	16.4 lbs.	
Environmental Specifications:		
Operating Temperature	-15°C to + 55°C	
Altitude	30,000 Feet	
Humidity	95% to 100% @ 50°C for 48 hours	
Dimensions:	See applicable outline drawings in I. B. 2012-1 Installation Manual	

1-6.

OPERATING CONTROLS AND THEIR FUNCTIONS

- A. All operating controls for the system (with the exception of the 14/28 vdc selector switch) are located on the front panel of the receiver (see Figure 1-1). The function of each control is as follows:
- B. FUNCTION SWITCH
- (1) The four-position rotary function switch controls the operating mode of the system.
 - (a) OFF. Disconnects the primary d-c source voltage from the system.
 - (b) ADF. Establishes the necessary circuit connections for automatic direction finder operation.

SECTION I

DESCRIPTION AND OPERATION

1-6. B.(1)

- (c) REC. Establishes the necessary circuit connections for broadcast superheterodyne receiver.
- (d) BFO. Establishes the necessary circuit connections for reception of A0 and A1 type signals. This mode also provides assistance in identifying weak or distant stations.

C. BAND SWITCH

- (1) The three-position rotary band selector switch selects the tuned circuits for the three frequency bands. The switch designations and frequency coverage are as follows:
 - (a) 200-400 selects range of 200-400 kHz
 - (b) 400-800 selects range of 400-800 kHz
 - (c) 800-1600 selects range of 800-1600 kHz

D. DIGITAL FREQUENCY SELECTOR

- (1) The digital frequency selector controls the digital tuning logic inputs in the receiver and displays the selected frequency. Tuning is automatic and is accomplished by positioning the band switch in the proper tuning range and simply dialing in the desired frequency on the Frequency Selectors.
- (2) When tuning the 201F ADF Receiver it will be apparent that the audio frequency response and audio level will increase slightly when tuned 1 or 2 kHz (depending on signal strength) on either side of the desired station. The correct tuning for optimum ADF performance will be the "exact station frequency" and not the point of loudest audio. This is true of any ADF receiver but will be noticed more readily in the 201F ADF Receiver because of the precise tuning.

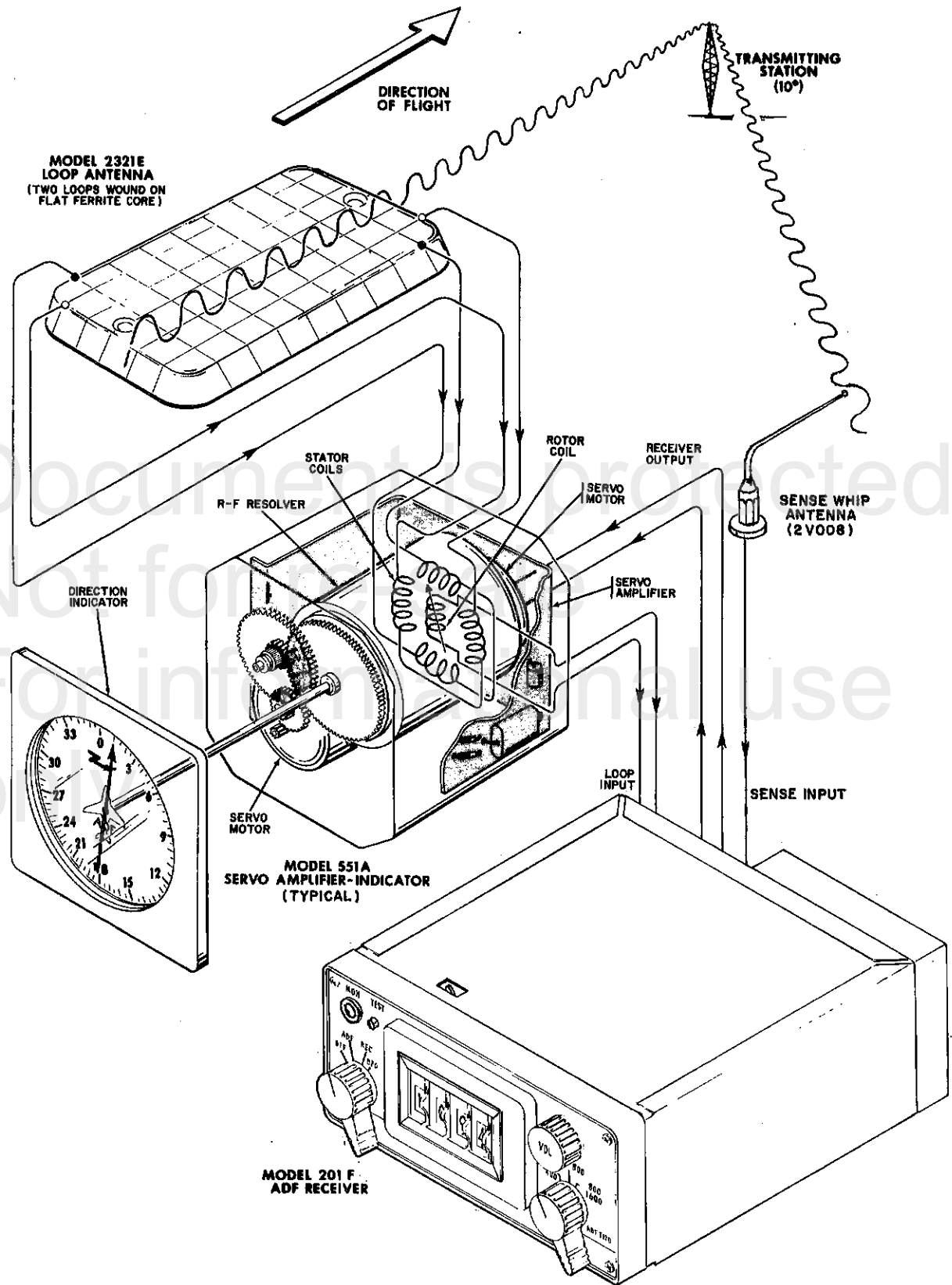
E. VOL (Volume) CONTROL

- (1) This knob is mechanically linked to the wiper arm of a potentiometer. The position of the wiper arm determines the audio output level of the receiver.

F. TEST BUTTON

- (1) The spring-loaded TEST button provides a quick operational check of the ADF-T12D system. When the receiver (in ADF mode) is tuned to a station, pressing the button will cause the indicator pointer to rotate away from the indicated bearing. If it is functioning properly, the indicator pointer will return to the station bearing upon release of the TEST button.

SECTION I
DESCRIPTION AND OPERATION



ADF Operation Simplified Pictorial Diagram
Figure 1-2

SECTION I

DESCRIPTION AND OPERATION

1-6.

G. MON (Monitor) LIGHT

- (1) The monitor light when illuminated indicates that the receiver is not tuned properly. When a frequency is dialed in the digital frequency selector and the band switch is not set to the proper band of frequencies the monitor light will come on. Presence of the light under any other condition indicates a malfunction has occurred in the receiver.

H. AZIMUTH CONTROL KNOB

- (1) The azimuth control knob on the 551RL is mechanically linked to the azimuth card. This allows 360 degree rotation of the card.

1-7. PRINCIPLES OF OPERATION (See Figures 1-2 and 1-3)

- A. As indicated in figure 1-2 the cross-wound coils of the fixed loop antenna are connected to the cross-wound coils of the r-f resolver located in the Servo Amplifier-Indicator. The voltages induced across the coils of the fixed loop antenna by the received signal cause proportional currents to flow through the stator coils of the r-f resolver. The currents, in turn, produce proportional magnetic fields that combine algebraically to produce a resultant magnetic field. The resultant magnetic field assumes the same conditions as the induced signal voltage at the fixed loop antenna.
- B. The magnetic field surrounding the stator coils of the r-f resolver induces a voltage in the resolver rotor coil. The amplitude and phase of this induced voltage is determined by the position of the axis of the rotor coil with respect to the axis of the magnetic field created by the stator coils. When the two axes are displaced by zero or 180 degrees, that is, parallel to each other, the induced rotor voltage is at a maximum. Similarly, there are two positions of the rotor coil that produce zero voltage. This occurs when the two axes are displaced at right angles to each other, that is, 90 and 270 degrees.
- C. The induced voltage developed across the r-f resolver rotor coil is the "error" input signal to the "servo loop" formed by the resolver rotor, the receiver, servo amplifier and the servo motor. The receiver converts the r-f rotor "error" voltage into a low-frequency motor control voltage, which is amplified and phase compared in the servo amplifier-indicator. The resultant signal is applied to the control windings of the d-c servo motor. This servo motor rotates and causes the resolver rotor coil to rotate to a position corresponding to zero output voltage. At this point, there is no input voltage applied to the receiver from the resolver rotor coil and therefore there is no low-frequency signal applied to the servo system. As a result, the servo motor stops rotating. A pointer, attached to the resolver rotor coil indicates the relative bearing of the "tuned in" transmitting station from the aircraft as read against the dial.

SECTION I

1-7.

DESCRIPTION AND OPERATION

- D. The direction from which the transmitted radio wave is received, that is, from the left or right of the aircraft, is therefore determined by the zero voltage or 'null' position of the resolver rotor coil with respect to the induced magnetic field surrounding the stator coils. There are two positions of 'null' (refer to paragraph B) and they occur 180° apart. The 'null' position that causes the indicator pointer to point to the true direction of the transmitting station is called the 'true' null. The other 'null' displaced 180 degrees from the 'true' null is called the 'false' null. A means of discerning between the 'true' and 'false' null indications is incorporated in the system that will cause the pointer to indicate 'true' null at all times. The manner in which this is accomplished is as follows:
- E. Due to the design characteristics of the cross-wound coils of the fixed loop antenna, the incoming loop r-f signal will either lead or lag the incoming sense r-f signal by 90 degrees. Whether the loop r-f signal leads or lags the sense r-f signal, is dependent upon the position of the transmitting station with respect to the loop antenna and the position of the resolver rotor coil.
- F. In order for the ADF indicator pointer to rotate in the proper direction and stop rotating at the correct aircraft to station relative bearing, a phase comparison or sampling between the loop r-f and sense r-f signals must be performed. The result, or phase of this 'sampling' will determine the direction of rotation of the servo motor. This, in turn will cause the ADF indicator pointer to rotate in the proper direction. This 'sampling' method is accomplished as follows:
- G. The loop r-f signal is phase-shifted an additional 90 degrees through means of capacitor C10, C11 or C12 (depending upon the position of the band selector switch). Depending upon whether the loop r-f signal originally leads or lags the sense r-f signal by 90 degrees, the additional phase shift will cause the loop r-f signal to be either in-phase or 180 degrees out-of-phase with the sense r-f signal.
- H. The 47 Hz low frequency switching action of the balanced modulator circuit, modulates or switches the incoming r-f signal at the loop antenna in such a manner as to alternately switch the loop r-f signal in-phase and 180 degrees out-of-phase with the constant-phase sense r-f signal during each complete cycle of 47 Hz switching voltage. The modulated loop r-f signal is amplified by isolation amplifier Q2 and the output combined with the incoming sense r-f signal. The low frequency modulated loop r-f signal alternately adds to and subtracts from the sense r-f signal and as a result, during one half-cycle of switching voltage (47 Hz) either an addition or subtraction takes place with the same r-f signal. Whether the loop signal, during 1st half-cycle of switching voltage, adds to or subtracts from the sense, is dependent upon the relative position of the r-f resolver rotor coil with respect to the field induced by the resolver stator windings. This in turn, is dependent upon the position of the loop antenna with respect to the transmitting station. The following example will facilitate the explanation given above:

SECTION I
DESCRIPTION AND OPERATION

1-7.

- I. With the tuned-in transmitting station at a relative bearing to the aircraft of 90 degrees to the right, the loop antenna will receive the incoming r-f signal at a maximum level in one of the internally cross-wound coils and at a minimum level in the other. Assume the two loop coils as A and B. Coil A being the coil that receives the signal at a maximum level. It will further be assumed that reception at coil A causes a 90 degree lead with respect to the constant-phase signal received at the sense antenna. Cross-wound coil A, directly connected to one pair of stator coils of the r-f resolver creates a maximum magnetic field in that pair of stator coils. Cross-wound coil B connected to the other pair of stator coils creates a minimum or virtually zero magnetic field. Depending upon the position of resolver rotor coil with respect to the induced magnetic field, the loop r-f signal will either lead or lag the incoming constant-phase sense r-f signal at the sense antenna by 90 degrees. In the example cited, the rotor coil is in a position such, that causes the loop r-f signal to lead the sense r-f signal by 90 degrees. A further 90 degree phase shift causes the loop r-f signal to become in-phase with the sense r-f signal.
- J. The first half-cycle of balanced modulator switching voltage, reverse the loop signal 180 degrees or causes it to become 180 degrees out-of-phase with the sense r-f signal. Upon mixing, the two signals cancel each other and as a result, zero r-f voltage exists at the output of the r-f amplifier. (Assuming equal sense and loop signals). During the next half-cycle of balanced modulator switching voltage, the loop r-f signal is reversed or "switched" back to its previous state, that is, to an in-phase condition with the sense r-f signal. Upon mixing, the two signals aid each other and as a result, maximum r-f voltage exists at the output of the r-f amplifier.
- K. Therefore, for a complete cycle of balanced modulator switching voltage, the loop r-f signal alternately subtracts from and adds to the constant-phase sense r-f signal. During amplification and demodulation, the resultant ADF signal maintains the same phase with respect to the power oscillator switching voltage in the servo amplifier unit.
- L. The ADF signal, in this case, is at a higher amplitude than the oscillator switching voltage due to the 90 degree relationship in the position of the resolver rotor coil with respect to the stators.
- M. The power oscillator signal, as applied to windings 7 and 9 of phase comparison transformer T1 (motor control amplifier) results in the ADF signal either being in-phase with the switching signal at winding 7 and out-of-phase with the switching signal at winding 9 or vice versa. From our example, we will assume that the former condition exists. Consequently, at winding 7 of transformer T1, both the ADF and switching signals aid each other and therefore add in amplitude while at winding 9 both signals cancel each other and therefore subtract in amplitude.

SECTION I
DESCRIPTION AND OPERATION

1-7.

- N. The resultant signals as observed at the bases of transistors Q5 and Q6 are such, that during the positive "swing" of the resultant signals, both transistors are "shut-off" or non-conducting. Hence, the servo motor "sees" zero voltage. Consequently, the motor does not rotate.
- O. During the negative swing of the resultant signals, both transistors are "turned on" or conducting. Due to the higher amplitude of the signal at Q5, heavier collector current flows at the output of Q5 than that of Q6. The voltages developed at the respective transistor outputs are filtered and applied to both windings of the servo motor as d-c voltages of different amplitudes and polarity.
- P. If the positive voltage developed across the motor from the output of Q5 causes clockwise rotation of the servo motor, the positive voltage developed from the output of Q6 will cause counterclockwise rotation of the motor.
- Q. The motor responds only to the differential between the two transistor outputs. In this case, the motor will rotate clockwise due to the higher amplitude signal current derived from the output of Q5.
- R. The r-f resolver rotor coil, mechanically coupled to the armature of the servo motor begins to rotate clockwise as does the ADF indicator pointer, which is linked to the r-f resolver rotor coil.
- S. The motor continues to turn until the developed magnetic field surrounding the rotor coil and the magnetic field surrounding the stators result in zero voltage at the output of the resolver.
- T. At this point, the loop r-f signal is absent in the receiver. Since phase comparison cannot be made with both the sense r-f and oscillator switching signals, the motor stops rotating and the indicated bearing as observed on the ADF Bearing Indicator will read 90 degrees.
- U. If cross-wound coil B receives the maximum signal and A the minimum, the opposite effect occurs. That is, the incoming loop r-f signal will lag the sense r-f signal by 90 degrees.
- V. The additional 90 degree phase shift, results in the loop r-f signal becoming 180 degrees out-of-phase with the sense r-f signal.
- W. Consequently, due to the switching action of the balanced modulator, the demodulated ADF signal as compared to the power oscillator switching signal across transformer T1 in the servo amplifier unit is opposite to that explained previously. As a result, the motor rotates in a counterclockwise manner and the indicator pointer will stop at 270 degrees on the dial.
- X. Due to the inertia of the motor together with noise modulation, in some cases, the ADF pointer will "overshoot" the "true" null position by approximately 5 degrees. The pointer will then reverse its rotation and stop at the true null position.

SECTION I

DESCRIPTION AND OPERATION

1-7.

- Y. Once the rotor coil passes through the "true" null position (overshoots), a reversal in phase of the loop r-f signal appears at the resolver output. This is due to the fact that the rotor coil has passed through the magnetic field created in the stator coils by a factor of 180 degrees with relation to the position of the transmitting station. As a result, the rotor begins cutting the magnetic field of the stator coils with reversed polarities to that previously encountered. Hence, the variable ADF signal in the servo amplifier is reversed by 180 degrees. When compared with the reference 47 Hz voltage, the resultant signal causes the servo motor to reverse its rotation, which in turn, brings the pointer back to the "true" null position.
- Z. The 47 Hz modulated loop r-f output of the balanced modulator is amplified by modulator isolation amplifier Q2 and applied to the input of sense r-f amplifier Q3 where it is further amplified and alternately added to the sense r-f signal. The resultant output of the sense r-f amplifier is applied to the input of the mixer stage, where, together with the output of the Voltage Controlled Oscillator, it is converted to an i-f frequency of 140.0 kHz. The signal is further amplified through the three stages of i-f and the output applied to the 2nd. detector where the audio, together with the 47 Hz modulation component is recovered from the i-f signal.
- AA. The output of the 3rd i-f amplifier is also applied to an automatic gain control (AGC) detector. The d-c component of the demodulated output of the AGC detector is amplified by the AGC amplifier and applied to the r-f amplifier stage, and both the 1st and 2nd i-f amplifier stages. The AGC voltage lowers the gain of the system upon reception of an r-f signal above a pre-determined amplitude.
- BB. The 47 Hz modulated audio signal is applied to the 1st audio amplifier (in the receiver) where it is amplified and applied to the input of the 1st audio amplifier Q1 in the servo amplifier-indicator. The audio signal is also applied to two more stages of amplification in the ADF receiver where it is finally reproduced in the headset output.
- CC. The optional speaker amplifier is connected to the headset output of push-pull audio power amplifier Q12 and Q13. The output of the push-pull amplifier circuit in the optional speaker amplifier is reproduced in the speaker.
- DD. The output of the 1st audio amplifier in the servo amplifier-indicator is applied to three additional stages of audio amplification where the signal is brought to the necessary amplitude required to drive the servo motor.
- EE. The output of the 4th audio amplifier is also applied to the input of the Sync. filter. The filter is designed and adjusted to reject the 47 cps component while feeding back the higher frequency audio components. Consequently, the original 47 cps signal applied to the input of the balanced modulator from the output of the power oscillator is recovered at the output of the 4th audio amplifier in the servo amplifier-indicator and applied to the control windings of the servo motor through motor control amplifier stage Q5 and Q6.

SECTION I

DESCRIPTION AND OPERATION

1.7.

- FF. The low-frequency power oscillator produces a nominal 47 Hz signal. This signal, besides being applied to the balanced modulator stage in the ADF receiver, is also applied to the motor control amplifier as a reference voltage. The recovered 47 Hz at the 4th audio amplifier output is compared in phase and amplitude with the 47 Hz reference voltage. The resultant signal serves to drive the servo motor in the proper direction.
- GG. The digital frequency synthesizer produces the tuning voltage that determines the operating frequency of the voltage-controlled oscillator. In turn, the voltage controlled oscillator which is the receiver's mixer injection oscillator determines the operating frequency of the receiver. The digital frequency synthesizer consists of the following stages:
1. Digital frequency selectors
 2. Programmable counters
 3. Phase detector
 4. 1,000 KHz crystal-controlled clock (1,000 KHz Reference Clock)
 5. 5-volt regulator
 6. Monitor (Out-of-lock Detector)
 7. BFO switch
- HH. In analyzing the synthesizer we will start with the synthesizer in a locked or stable condition. In this locked condition the voltage-controlled oscillator (VCO) is running at the correct frequency which (because the receiver uses a 140 KHz IF frequency) is 140 KHz above the frequency selected on the front panel frequency selection switches.
- II. Besides going to the mixer, the r-f output from the VCO goes to the programmable counters. These counters are set by the digital frequency selectors to divide the VCO input by 140 plus the frequency selected on the front panel switches. When the VCO is operating correctly the output from the programmable counters will be a 1KHz signal.
- JJ. From the programmable counters the 1 KHz signal goes to the phase detector. The phase detector compares this signal with the 1 KHz clock signal and generates a d-c voltage that is proportional to the phase difference between the two signals. Depending on the frequency selected, the d-c voltage varies between 1.25 vdc and 6.5 vdc. This voltage is used to tune the receiver tuned circuits and the VCO.

SECTION I

1.7.

DESCRIPTION AND OPERATION

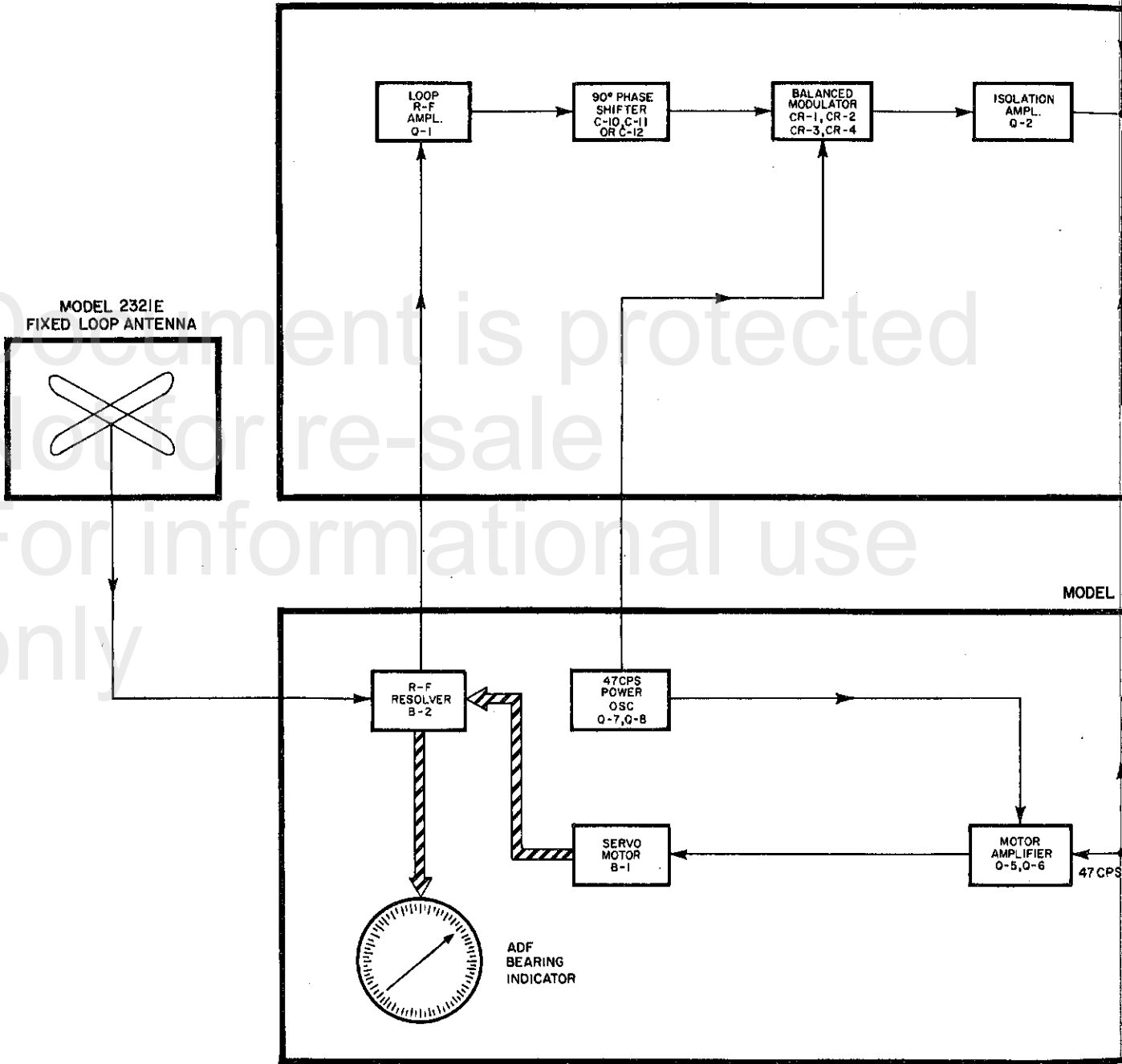
KK. If the VCO drifts off frequency (goes out-of-lock) the output of the programmable counters will not be 1 kHz. The phase detector will increase or decrease the tuning voltage to the VCO which will bring the VCO frequency back to the correct frequency. Again the VCO is in a locked condition. When the frequency selected on the front panel switches is changed the synthesizer will momentarily go out of lock also. This is because the dividing ratio of the programmable counters is changed and the output of the counters is no longer 1 kHz. As soon as the phase detector compares the counter output and 1 kHz clock signals, the tuning voltage to the VCO is changed. The VCO frequency changes, the programmable counter output becomes 1 kHz, and the synthesizer is again locked.

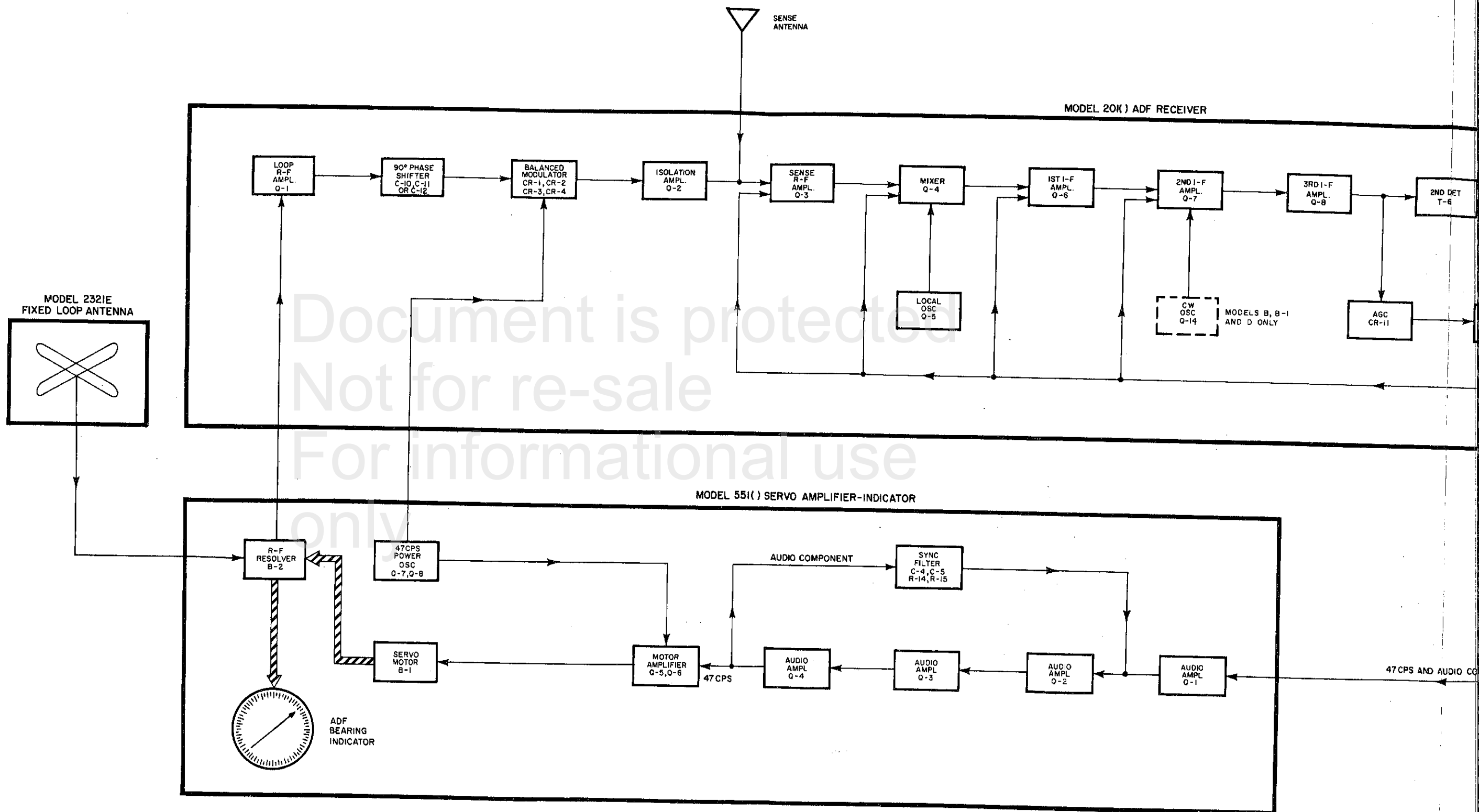
LL. Anytime a phase difference exists between the programmable counters output and the 1 kHz-clock signal, an out-of-lock detector circuit is enabled which lights a front panel monitor light. When the phase difference ceases, the monitor light goes out.

1.8 PHASE RELATIONSHIPS

- A. The phase relationships that exist between the loop r-f, sense r-f and the low frequency (47 Hz) modulating signals during ADF mode of operation are indicated in Figure 1-4.
- B. Normally, the modulated voltage waveforms shown in the illustration, if observed on a "scope" would appear as square waves. The sine waves depicted are shown for clarity and ease of understanding. The numbers in parentheses listed below correspond to the numbers to the left of each waveform in the illustration. The explanation follows the corresponding number for each of the waveforms illustrated.
- (1) The output of the sense antenna is of constant phase.

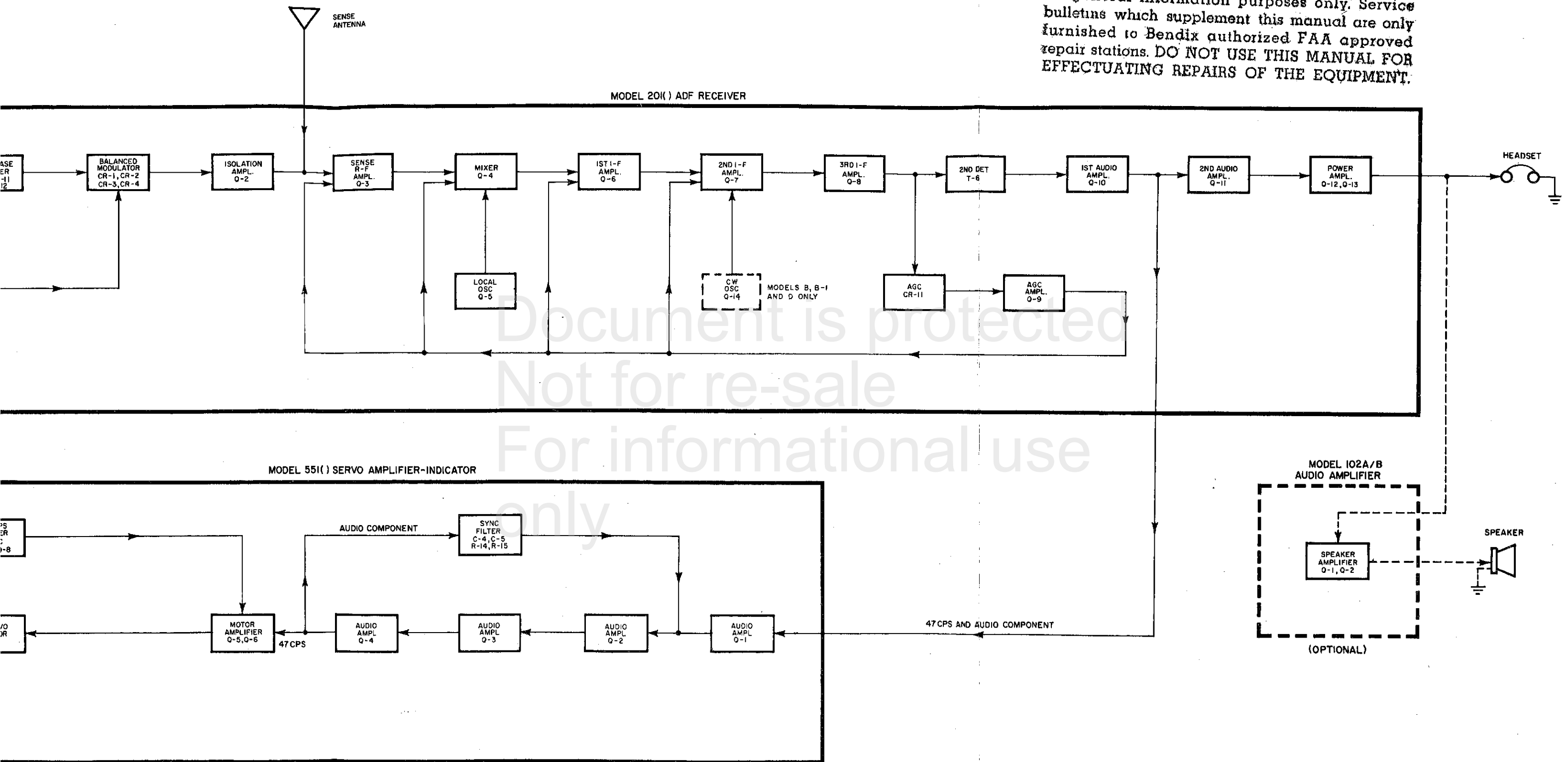
Document is protected
Not for re-sale
For informational use
only





WARNING

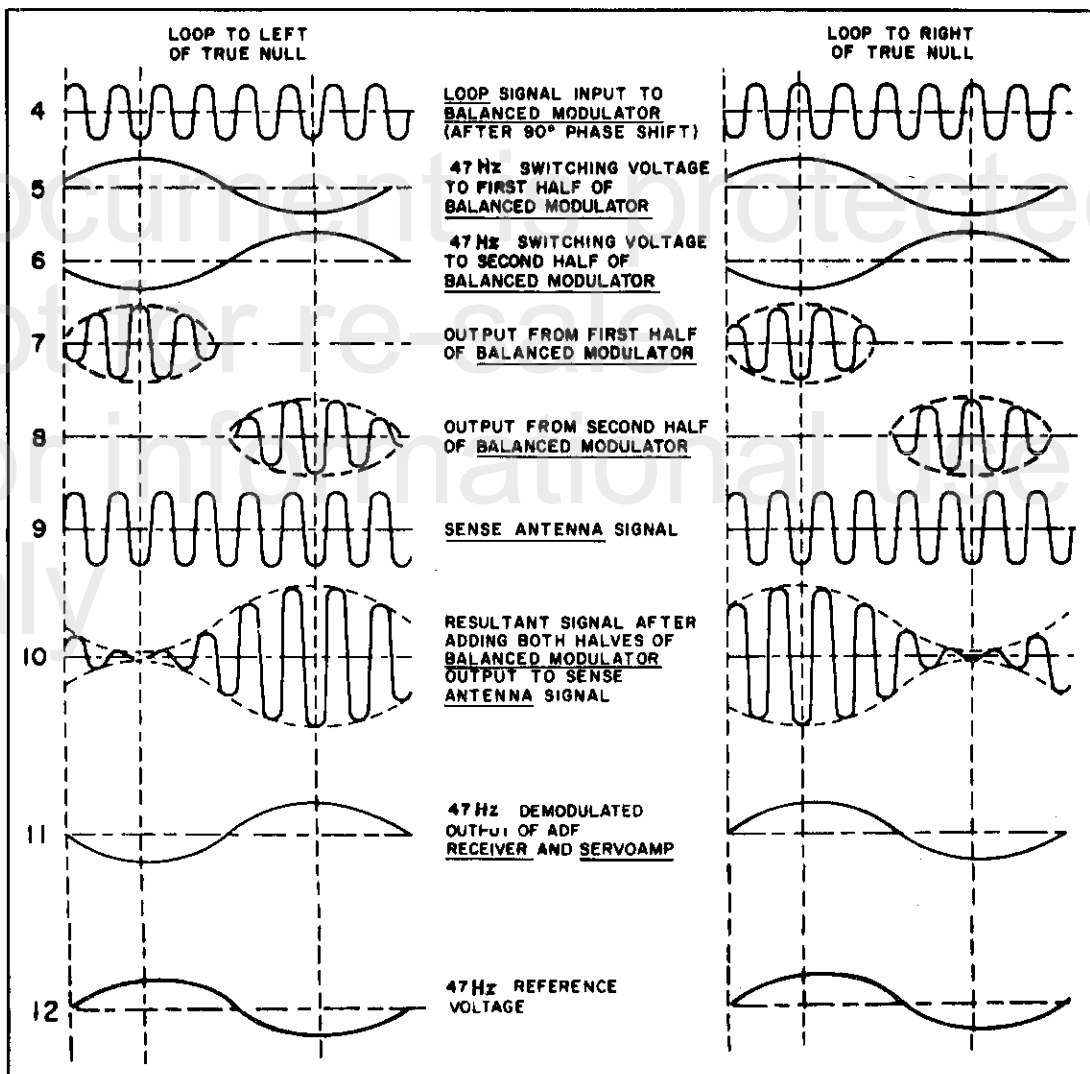
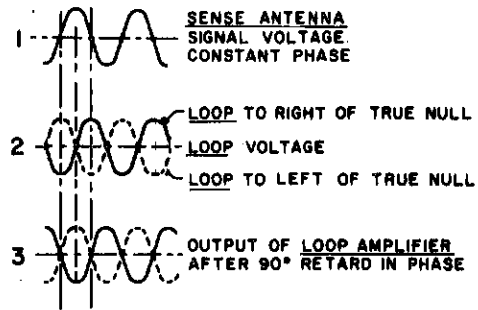
This manual which you have requested is furnished for general information purposes only. Service bulletins which supplement this manual are only furnished to Bendix authorized FAA approved repair stations. DO NOT USE THIS MANUAL FOR EFFECTUATING REPAIRS OF THE EQUIPMENT.



Block Diagram, ADF-T-12B, C System
Figure 3

April 1965

SECTION I
DESCRIPTION AND OPERATION



Phase Relationships
Figure 1-4

SECTION I
DESCRIPTION AND OPERATION

1-8. B.

- (2) The output of the resolver rotor coil (loop antenna input signal) is 90-degrees out-of-phase with the sense antenna r-f input signal and either leads or lags the sense r-f (by 90 degrees) depending on whether the resolver rotor coil is to the right or left of the "true" null position.
- (3) The resolver rotor signal is shifted in phase an additional 90 degrees. This results in the output of the loop r-f amplifier being in phase or 180 degrees out-of-phase with the incoming sense antenna signal.
- (4) The resolver rotor coil output signal is applied to the input of the balanced modulator.
- (5) and (6) The low-frequency output (47 Hz) of the power oscillator is also applied to the input of the balanced modulator. The modulation voltage (47 Hz) causes the four diodes of the balanced modulator circuit to be switched (as pairs) on and off in phase opposition during each half-cycle of the modulating voltage.
- (7) and (8) The balanced modulator produces a 47 Hz modulated loop r-f output signal in which the phase of the r-f component undergoes a 180 degree phase reversal during each half-cycle of the modulating signal (47 Hz). The phase of the loop r-f output of each pair of diodes in the balanced modulator with respect to the resolver rotor input voltage is a function of the position of the rotor coil with respect to the "true" null position.
- (9) The sense antenna signal (1) is illustrated again, below the output of the balanced modulator (7 and 8) for clarification.
- (10) When the resolver rotor coil is to the left of "true" null, the sense and loop r-f signals combine in the sense antenna transformer and reinforce the output of one pair of diodes in the balanced modulator circuit and reduces that of the other pair. When the rotor coil is to the right of "true" null, the same effect occurs but in opposite sequence.

1-9. RECEIVER (REC) OPERATION

- A. When operating the system in the REC position the following ADF circuits and components become inoperative.
 1. Model 2321 fixed loop
 2. Loop r-f amplifier circuit
 3. Balanced modulator circuit
 4. Isolation amplifier circuit
 5. Model 551() servo amplifier-indicator

SECTION I

DESCRIPTION AND OPERATION

1-9.

- B. Operating in the BFO position is the same as operating in the REC position except an additional output signal from the 1 kHz clock is applied to the second i-f amplifier. This signal enables the receiver to generate a 1000 Hz tone upon receiving type A0 and type A1 Transmissions.

Document is protected
Not for re-sale
For informational use
only

Document is protected
Not for re-sale
For informational use
only

SECTION II
DETAILED CIRCUIT DESCRIPTION

2-1. LOOP R-F AMPLIFIER (See Figure 6-1, Sheet 1)

- A. The loop amplifier Q1 functions as a common-emitter amplifier. The r-f error signal from the resolver rotor is introduced into the base-emitter circuit and extracted from the collector-emitter circuit.
- B. Forward bias is applied to Q1 by connecting the emitter to the regulated 9.1 vdc line through emitter resistors R3 and R4 which are by-passed for r-f by capacitor C9 and connecting the base of Q1 to the junction of the voltage divider formed by resistors R1 and R2.
- C. Resistor R3 causes the emitter-base junction resistance to be a small percentage of the total emitter resistance and in consequence, reduces the effect of emitter-base junction resistance variations with temperature.
- D. The error signal output of Q1 is developed across the primary winding of T1. The required 90 degree phase shift in the output signal is obtained by connecting one of three capacitors, C10, C11 or C12 in parallel with the primary winding of T1.
- E. Four sections of band switch S1 are employed in connection with loop amplifier Q1. Wafers S1/A and S1/C select one of three r-f coupling transformers L1, L2 or L3. Wafer S1/B connects voltage variable capacitance diode (varicap) CR15 across the secondary winding of the selected r-f coupling transformer. Varicap diode CR15 capacitively tunes the selected coupling transformer and circuit to the proper resonant frequency. Section S2/B selects the appropriate phase-shift capacitor C10, C11 or C12 for the collector circuit.
- F. The result of this phase-shift causes the output of the loop amplifier Q1 to be either in-phase or 180 degrees out-of-phase with the sense antenna signal depending on whether the resolver rotor coil is to the right or left of the true null position.

2-2. SENSE R-F AMPLIFIER

- A. Sense r-f amplifier Q3 is a common-emitter AGC-controlled amplifier. The base of Q3 is returned to the positive AGC line through a filter network consisting of R10, R11, C15 and L13. The emitter of Q3 is connected to the regulated d-c line through emitter resistor R12. A diode CR5 is connected between the emitter of Q3 and the junction of the voltage divider formed by resistors R13 and R14.
- B. Under quiescent conditions the emitter current through resistor R12 creates a voltage drop that causes diode CR5 to be forward biased and conducting. This condition places by-pass capacitor C23 across emitter resistor R12. As the level of the incoming signal increases, the positive AGC voltage increases and reduces the forward bias and gain of Q3. If the forward bias on Q3 falls below the peak value of the input signal, clipping results. However, as the forward bias decreases, the positive emitter voltage increases until eventually diode CR5 becomes reverse-biased and non-conducting.

SECTION II
DETAILED CIRCUIT DESCRIPTION

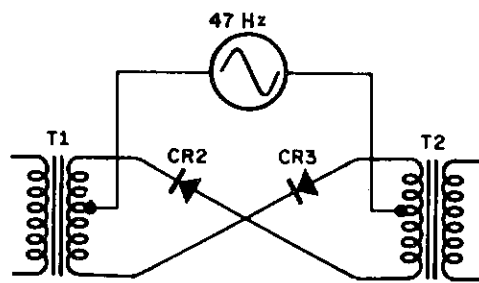
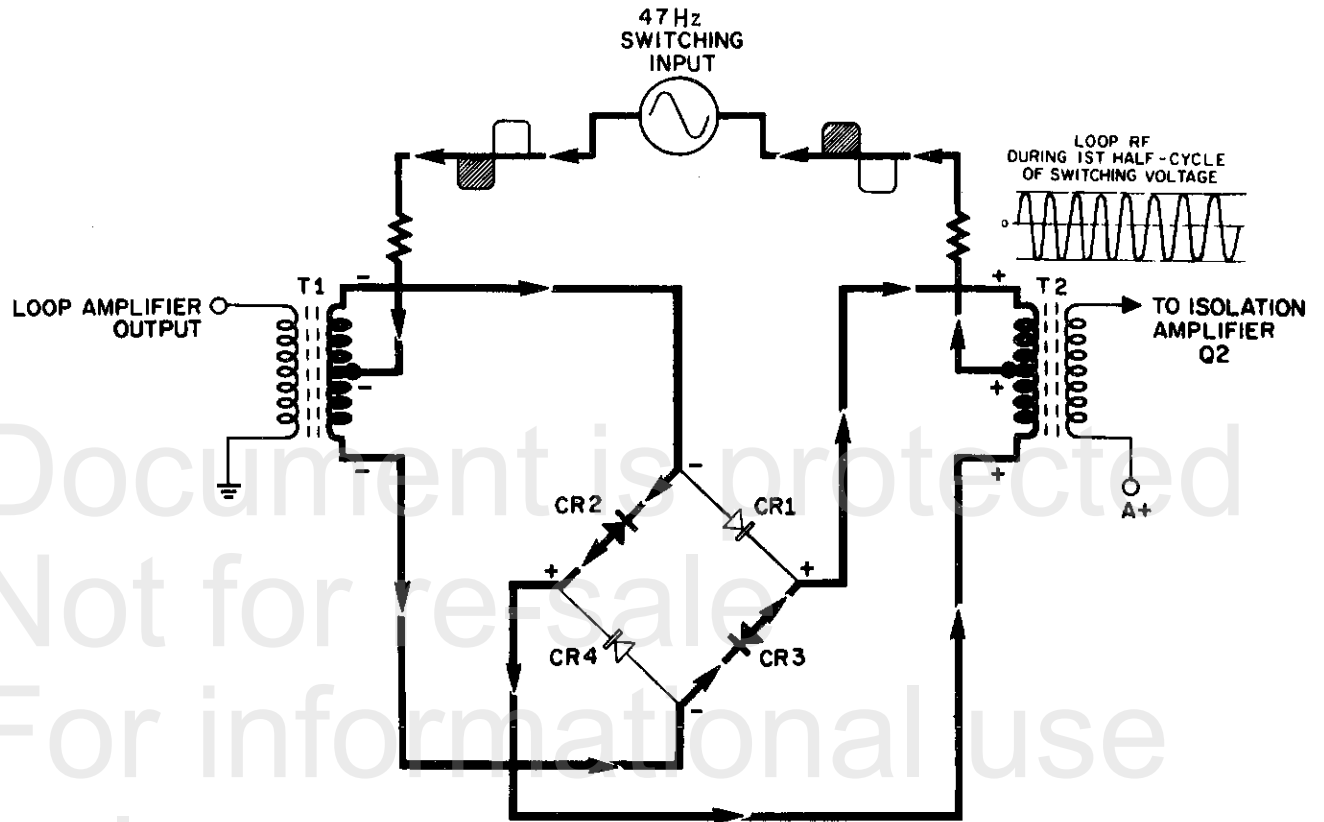
2-2.

- C. This transition is gradual due to the characteristics of diode CR5 and results in emitter by-pass capacitor C23 being gradually removed from the emitter of Q3. The gradual removal of C23 provides proportional negative current feedback to the input circuit and effectively extends the range of the AGC characteristics without clipping of the input signal at high levels.
- D. The path of the signal from the balanced modulator and the sense antenna to Q3 is determined by S3. Wafers S3/A and S3/C select one of the three interstage coupling transformers L4, L5 or L6. Wafer S3/B connects varicap diode CR14 and the sense antenna input signal across the secondary winding of the selected interstage coupling transformer.
- E. Varicap diode CR14 capacitively tunes the selected transformer and circuit to the proper resonant frequency. Capacitor C22 provides a means of capacitively trimming the sense antenna input to optimize performance.

2-3. BALANCED MODULATOR

- A. The balanced modulator stage consists of r-f transformers T-1 and T-2 together with a ring modulator bridge comprised of diodes CR1 through CR4. The circuit is re-drawn for ease of explanation in Figures 2-1 and 2-2.
- B. The purpose of the balanced modulator stage is to modulate or switch the incoming loop r-f signal 180 degrees at a rate of 47 Hz and mix this signal with the incoming sense r-f carrier. The phase of the resultant signal is such, as to drive the servo motor in the proper direction. The degree of rotation being dependent upon the amplitude of the received r-f signals at the loop and sense antenna.
- C. The output of the 47 Hz power oscillator located in the servo amplifier-indicator is applied to the input of the balanced modulator through the center-tapped windings or r-f transformers T-1 and T-2.
- D. It will be assumed the first half-cycle of the applied 47 Hz voltage causes the center-tap of transformer T1 to become negative and the center-tap of T2, positive.
- E. Therefore, during the first half-cycle of the incoming switching voltage, diodes CR2 and CR3 are conducting in the direction shown in Figure 2-1, and diodes CR1 and CR4 are considered "open" or nonconducting. This action is realized due to the existing distributed polarities across the individual diodes. In this case, diodes CR2 and CR3 are forward biased to conduction because of the assumed phase of the incoming half-cycle. That is, the cathodes of both CR2 and CR3 are more negative with respect to their anodes which is the primary requirement of conduction through the two diodes. On the other hand, diodes CR1 and CR4 develop polarities of the opposite direction and therefore cannot conduct during the first half-cycle of applied switching voltage.

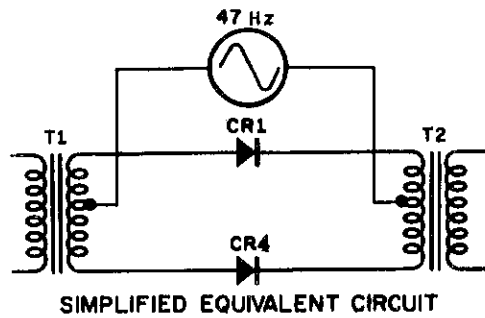
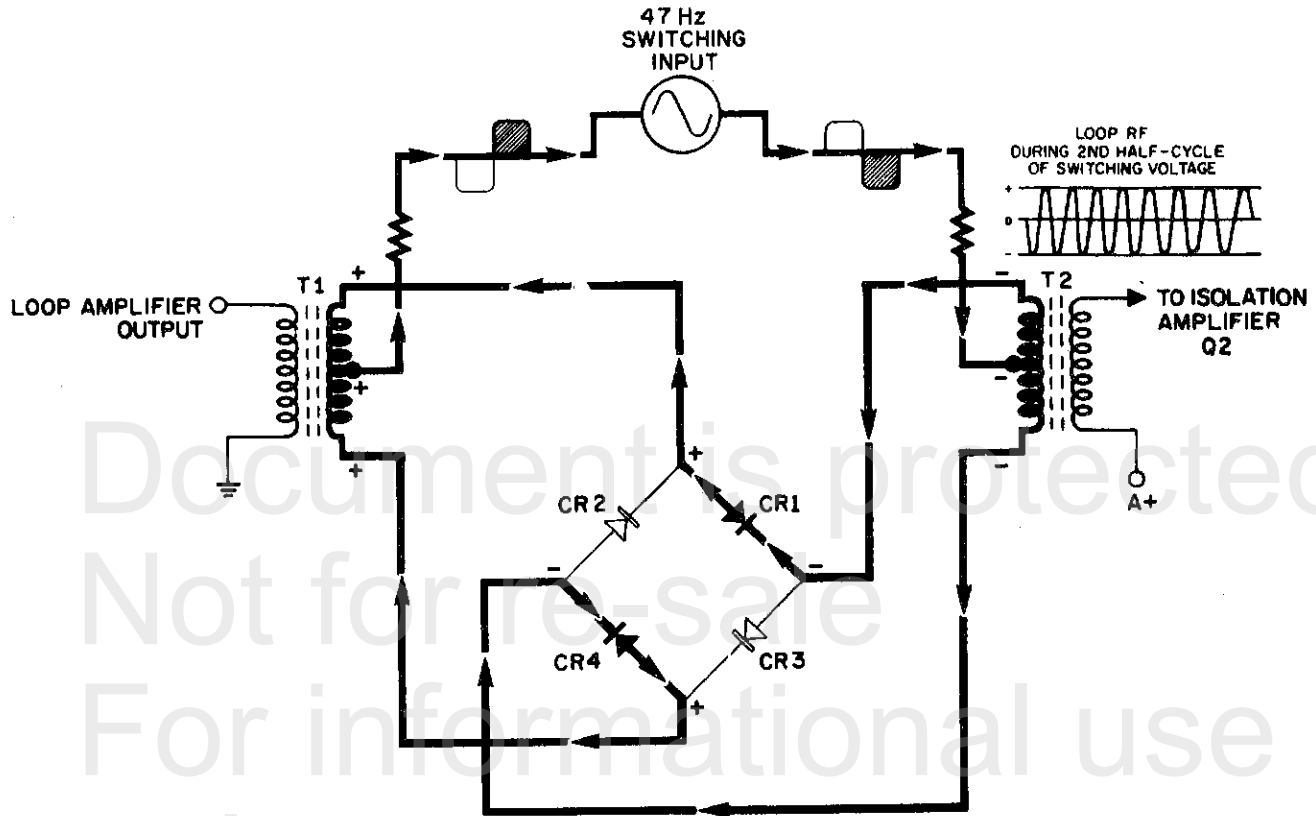
SECTION II
 DETAILED CIRCUIT DESCRIPTION



SIMPLIFIED EQUIVALENT CIRCUIT

Balanced Modulator (Condition 1) Simplified Schematic
 Figure 2-1

SECTION II
 DETAILED CIRCUIT DESCRIPTION



Balanced Modulator (Condition 2) Simplified Schematic
 Figure 2-2

SECTION II

DETAILED CIRCUIT DESCRIPTION

2-3.

- F. During the first-half cycle of applied switching voltage, the incoming loop r-f signal is switch 180 degrees by the half-cycle of switching voltage conducted through diodes CR2 and CR3.
- G. During the next half-cycle of the incoming switching voltage, diodes CR2 and CR3 are "shut-off" or non-conducting while diodes CR1 and CR4 are conducting in the direction shown in figure 2-2. The polarities of the four diodes therefore reverse themselves from that of the first-half cycle of switching voltage. In this case, the conducting path through the circuit is now 180 degrees out-of-phase with the conducting path of the first half-cycle as can be seen by comparing the simplified equivalent circuits below each figure in the illustration.

2-4. MIXER

- A. The output of sense r-f amplifier Q3 is transformer coupled to the base of mixer Q4 through coupling transformer L7, L8 or L9, depending upon the position of band switch wafers S4/A and S4/C.
- B. The primary of the selected coupling transformer is capacitively tuned by varicap diodes CR15 and CR16. The output of the voltage controlled oscillator (VCO) Q14 which is 140.0 kHz higher than the r-f signal frequency, is also applied to the base of mixer Q4 through coupling capacitor C30, the secondary winding of the selected coupling transformer and band switch wafer SR/C.
- C. Mixer Q4, which operates as a common-emitter non-linear amplifier, combines the incoming r-f signal with the output of the VCO to produce a fixed intermediate frequency (i-f) of 140.0 kHz. This signal is applied across the primary winding of i-f transformer T3, which is also tuned to 140.0 kHz.

2-5. VOLTAGE CONTROLLED OSCILLATOR (VCO)

- A. The voltage controlled oscillator (VCO) provides a variable frequency r-f signal to the mixer and synthesizer. Frequency control of the VCO is accomplished by application of tuning voltages to varicap diode CR17. Tuning voltages for the VCO are developed in the phase detector circuitry in the synthesizer. For any given station frequency selected the VCO frequency is always maintained 140.0 kHz above the station frequency.
- B. The output signal from the VCO heterodynes with the incoming station signal in the mixer. Heterodyning of the two signals in the mixer produce at the output of the mixer the two fundamentals, the sum and difference frequencies. Since the VCO is operating 140.0 kHz above the incoming frequency the difference frequency is equal to 140.0 kHz. This 140.0 kHz signal is applied to the tuned 140.0 kHz intermediate frequency stages for further amplification.

SECTION II

2-5.

DETAILED CIRCUIT DESCRIPTION

- C. As mentioned earlier a second output from the VCO is applied to the synthesizer. This signal is used to clock and gate the programmable counter in the synthesizer.
- D. The voltage controlled oscillator is a tuned base oscillator. Frequency selection is accomplished within each band by varying the capacitance of the selected tuned circuits over a 4 to 1 capacitance range and between bands by selecting one of three individual parallel tuned circuits.
- E. Printed circuit board TB4 contains the active elements of this circuit. These consist of field effect transistor Q5, used as a high input impedance amplifier to avoid loading the tank circuit and transistors Q14 and 15, used as a voltage amplifier. Transistor Q15 is a low impedance emitter follower which drives the mixer.
- F. Level control is provided by the limiting action of transistor Q16. The signal is fed from the collector of this transistor through a voltage divider to one of the three parallel tuned circuits. Feedback adjust potentiometer R87 provides a means for setting the VCO r-f signal level (injection voltage) to the mixer.

2-6. I-F AMPLIFIERS DETECTOR

- A. The fixed intermediate frequency (i-f) output of mixer Q4 is coupled through i-f transformer T3 to the fixed-tuned three stage i-f amplifier consisting of transistors Q6, Q7 and Q8.
- B. AGC voltage is applied to the bases of Q6 and Q7 through AGC filters R26 and C44, R31 and C47, respectively. I-f amplifiers Q6 and Q7 also feature AGC controlled negative current feedback similar to that described for sense r-f amplifier Q3. This feature is accomplished in the case of Q6 by diode CR9, voltage-divider R28 and R29, and emitter by-pass capacitor C46. In Q7 it is accomplished by diode CR10, voltage divider R33 and R34 and emitter by-pass capacitor C49.
- C. The emitters of Q6, Q7 and Q8 are returned to the regulated d-c line through swamping resistors R27, R32 and R37 respectively.
- D. The output of the 3rd i-f amplifier Q8 is coupled to detector transformer circuit T6. TP1 is provided at the output of the 3rd i-f amplifier Q8 for signal observation.
- E. Within T6 the signal is rectified, the r-f component is by-passed to ground through filter capacitors and the audio output is coupled to the base of Q10 through coupling capacitor C57.

2-7. AGC DETECTOR AND AMPLIFIER

- A. The output of the 3rd i-f amplifier Q8 is also coupled through capacitor C52 and resistor R38 to the reverse-connected AGC diode detector CR11. The demodulated negative d-c output of CR11 tends to discharge capacitors C53

SECTION II
DETAILED CIRCUIT DESCRIPTION

2-7. A.

and C54. Under static conditions C53 and C54 are charged positively to a voltage level existing at the junction of the voltage-divider formed by resistor R39, forward biased diode CR11 and resistor R38. The positive bias on the base of AGC amplifier Q9 is thereby reduced from the static level by the introduction of an i-f signal. Furthermore, the greater the amplitude of the i-f signal, the greater is the reduction of the positive bias at the base of Q9.

- B. The emitter of Q9 is connected to the junction of resistors R40 and R41, which together with thermistor RT1 form a voltage-divider across the regulated 9.1 volt d-c line.
- C. The collector of Q9 is connected to the regulated d-c line through collector load resistor R42. A positive bias is applied to the base of Q9 from the junction of resistor R39 and CR11 as explained in the preceding paragraphs. Under these static conditions AGC amplifier Q9, which is a NPN type transistor, is forward biased toward maximum conduction. The heavy collector current of Q9 flows through load resistor R42 and develops a voltage-drop that opposes the 9.1-volt regulated d-c line voltage. Capacitor C55, therefore, charges to the resultant of these two voltages, which under static conditions is approximately 2.2 vdc. TP2 is provided to allow measurement of this voltage.
- D. As previously explained an incoming i-f signal reduces the forward bias on Q9 and consequently the collector current. When the collector current of Q9 decreases the voltage on capacitor C55 (and the AGC line), increases toward the 9.1 volt level of the regulated d-c line. Thus the positive voltage on the AGC line increases as the amplitude of the incoming i-f signal increases. The AGC line is connected through separate filter networks to the bases of sense r-f amplifier Q3 1st i-f amplifier Q6, and 2nd i-f amplifier Q7. These stages employ PNP type transistors which require negative forward-bias for conduction. The effect therefore of the increasing positive AGC bias caused by an increasing i-f signal, is to reduce the forward-bias and hence the gain of the controlled stages.

2-8. AUDIO AMPLIFIER

- A. The audio signal from the detector circuit T6 is coupled to the base of Q10 through coupling capacitor C57. Resistors R45 and R46 provide proper loading of the detector output. Capacitor C56 by-passes audio frequencies above 3000 Hz to ground. Transistor Q10 operates as an audio amplifier in the common-emitter configuration. Base bias is determined by resistors R47 and R48. The emitter of Q10 is connected to the regulated 9.1 vdc line through resistor R49. The collector load resistor for Q10 is preset potentiometer R51. Capacitor C59 provides high frequency cutoff for frequencies above 3000 Hz. Preset audio potentiometer R51 determines the level of audio signal delivered to the final audio output stages Q11, Q12 and Q13. This preset level limits the maximum audio output of the audio amplifier.

SECTION II
DETAILED CIRCUIT DESCRIPTION

2-8.

- B. The ADF servo signal output (47 Hz) is coupled from the emitter of Q10 and through resistor R50 to pin 16 of rear connector J1. Capacitor C60 by-passes frequencies above 47 Hz to ground.
- C. The output signal from Q10 is coupled from the wiper of preset potentiometer R51 through volume (VOL) potentiometer R52, coupling capacitor C61 and applied to the base of transistor Q11. Volume control is accomplished by varying the audio signal input and degenerative feedback of transistor Q11 in the following manner.
- D. As the volume control potentiometer R52 is rotated clockwise (from right to left on schematic) the resistance in the degeneration or negative feedback path of Q11 increases and lowers the degeneration voltage which increases the gain of Q11. At the same time the resistance in the path of the audio signal is reduced, which increases the audio input signal level to Q11. By controlling the gain and audio input levels simultaneously a greater dynamic range of audio control can be accomplished.
- E. Resistors R53 and R54 determine the base bias for Q11. The emitter is connected to the 9.1 vdc regulated line through resistor R55. The amplified output of Q11 is applied across the primary winding of phase inverter transformer T7. Capacitor C62 by-passes frequencies above 3000 Hz to ground. The audio signal is coupled to the bases of push-pull amplifier transistors Q12 and Q13.
- F. The push-pull amplifier employs forward-biased junction diode CR12 as a temperature sensitive element to compensate for variations of emitter-base junction resistance. The voltage-divider consisting of CR12 and resistor R56 makes the bases of Q12 and Q13 negative with respect to their emitters, which are connected to the 9.1 vdc regulated line through limiting resistors R58 and R59. Increased temperature tends to increase collector current. However, increased temperature decreases the resistance of diode CR12, causing more current to flow through the voltage-divider. As a result there is an increased voltage drop across R56. The voltage drop across diode CR12 is correspondingly decreased, thereby reducing the forward bias and the collector current.
- G. The amplified audio output of push-pull amplifier Q12 and Q13 is developed across the secondary winding of output transformer T8. The secondary winding provides the correct impedance match for the 500 ohm headset or the speaker power amplifiers when used.

SECTION II
DETAILED CIRCUIT DESCRIPTION

2.9. SYNTHESIZER (Figure 6-1, Sheet 2)

The purpose of the synthesizer is to supply to the VCO a tuning voltage that will produce a frequency 140 KHz above the frequency selected on the front panel frequency selection switches. The synthesizer may be analyzed like any typical feedback system. Refer to figure 2-3. When the reset frequency of the programmable counter (F_r) is not the same as the frequency of the 1 kHz reference clock (F_{rc}), the tuning voltage produced by the phase detector will cause the VCO to sweep in frequency. While the VCO is sweeping, there will be an instant or point in time when

$$F_{vco} = (F_{rc}) (N+140)$$

$$\text{and } F_r = \frac{F_{vco}}{N+140} = 1 \text{ kHz}$$

When this condition exists, the VCO is synchronized and the system is in a locked condition. As an example, assume a frequency of 1490 kHz is selected on the front panel.

$$N = 1490$$

From the frequency selectors,

$$N + 140 = 1630$$

From the VCO,

$$F_{vco} = (F_{rc}) (N+140)$$

$$= (1) (1630)$$

$$= 1630$$

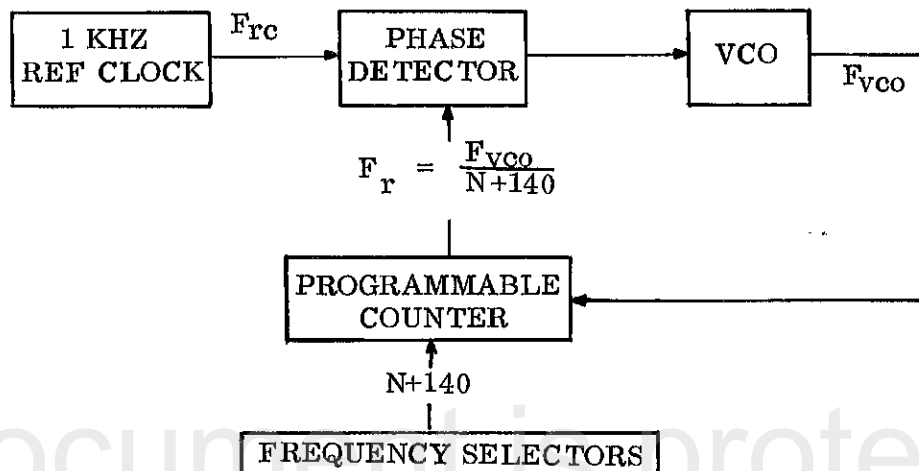
And from the programmable counters,

$$F_r = \frac{F_{vco}}{N+140}$$

$$= \frac{1630}{1630}$$

$$= 1$$

SECTION II
DETAILED CIRCUIT DESCRIPTION



Simplified Tuning Logic
Figure 2-3

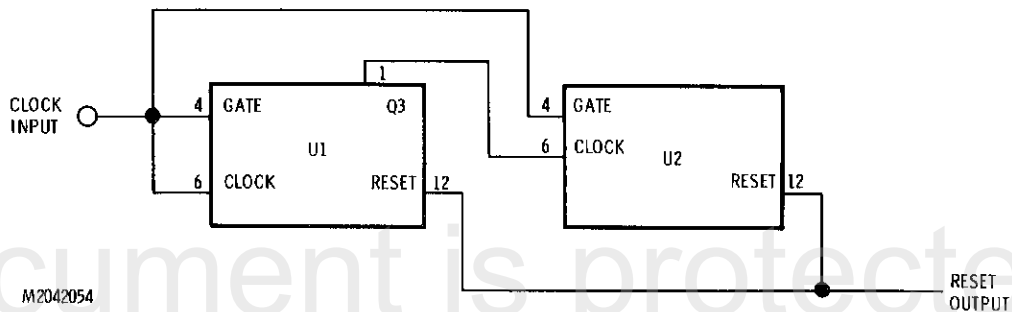
2.10. PROGRAMMABLE COUNTER

- A. The heart of the synthesizer is the programmable counter, and the heart of the programmable counter is the programmable decade down-counter. Counting action of a programmable decade down-counter starts with the application of a reset pulse. At this time, the preset state desired is entered into the counter. This sets the initial state to a number from 0 to 9 from which the counter is counted down towards 0. Each clock pulse applied will clock (count down) the counter from the preset number to the next lower number. Successive clock pulses bring the counter to 0 at which time a reset pulse is generated unless the reset pulse terminal is grounded by a low level on the reset pulse terminal of another cascaded counter.

If the reset pulse terminal is not grounded, the next clock pulse will recycle the counter to the preset state. Assuming the reset pulse terminal is grounded the counter will automatically recycle to the number 9 regardless of the number preset. From 9 the counter will count down to 0 through ten successive stages, and thus divide by ten.

SECTION II
DETAILED CIRCUIT DESCRIPTION

- B. When decade down counters are connected in series, recycling is controlled by the last counter in the series. This results in one additional 9 to 0 down-count cycle of each counter preceding the last counter. As an example assume two decade down-counters are connected in series as shown in figure 2-3A.

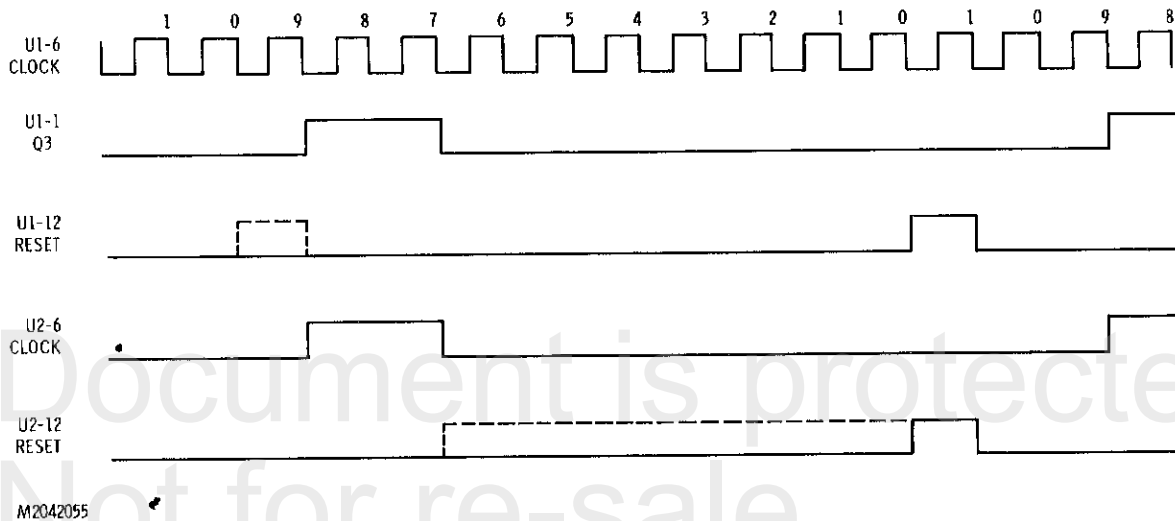


Two-Stage Programmable Decade-Counter
Simplified Schematic Diagram
Figure 2-3A

U1 is preset to 2 and U2 is preset to 1. Twelve input pulses are desired for one output pulse from the reset pulse terminal bus. Figure 2-3B is a timing diagram of this two stage counter.

The counter used triggers on the transition of the clock signal from high to low level. After two input pulses to U1 this counter is at 0 and conditions are correct for U1 to produce a reset pulse at pin 12. However, the reset pulse from U1 pin 12 is inhibited because of the low level from the reset pulse terminal (pin 12) of U2. This terminal (U2 pin 12) remains at a low level until U2 is clocked by the drop to a low level of U1 clock output at U1 pin 1. Now conditions are correct for U2 to produce a reset pulse at U2 pin 12, but the low level at U1 pin 12 inhibits the reset pulse until U1 is clocked down to 0 once again. This is the one additional 9 to 0 down-count cycle previously mentioned. When U1 is clocked down to 0 conditions are correct for a reset pulse at pin 12. Since conditions are already correct for producing a reset pulse from U2 pin 12 both counters are recycled to their preset state.

SECTION II
DETAILED CIRCUIT DESCRIPTION



Timing Diagram of Two-Stage Programmable Decade Counter
Figure 2-3B

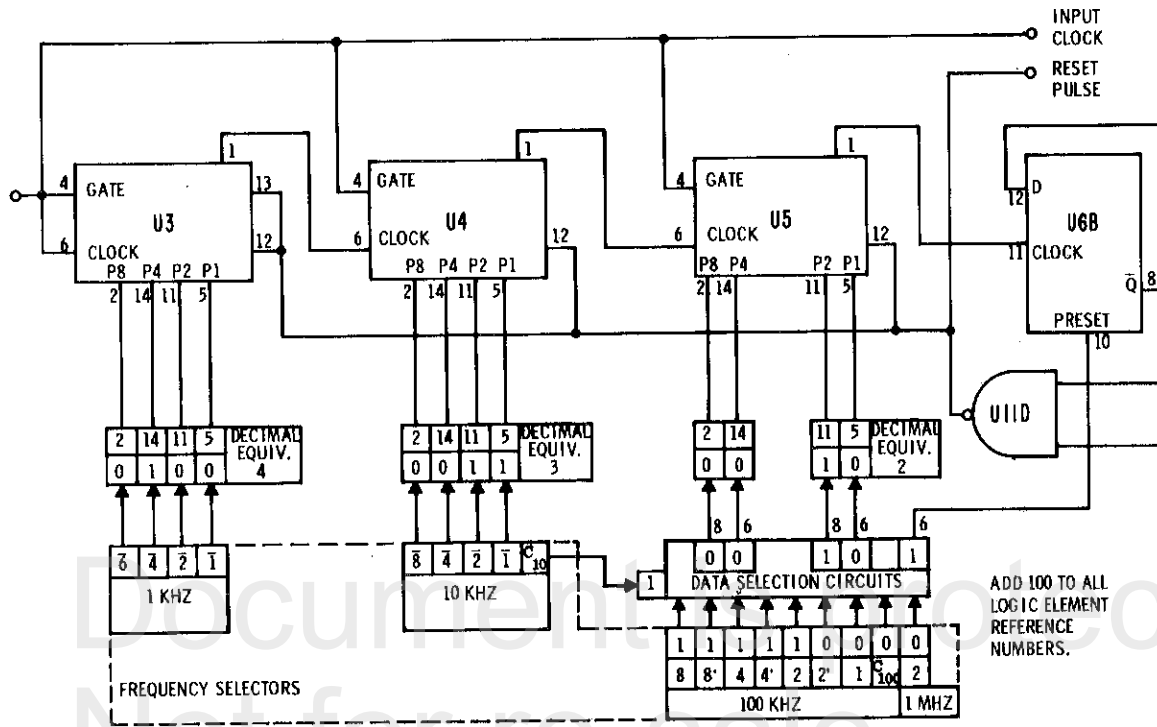
- C. The programmable counter in the ADF-T12D provides a pulse train to the input pin 3 of phase detector U115. Pulses from the programmable counter vary in frequency and period as determined by the logic conditions on inputs P8, P4, P2, P1 of each counter and the frequency and period of the pulses from the VCO.

- D. Refer to figure 6-1 sheet 2. The VCO supplies a pulse train to the base of buffer amplifier Q104 through coupling capacitor C105 and resistor R114. Negative portions of the pulse train are shunted to ground through clipping diode CR101. Positive bias is supplied to the base of Q104 through resistor R115. The collector of Q104 is connected to the regulated 5 vdc line through resistor R116.

SECTION II
DETAILED CIRCUIT DESCRIPTION

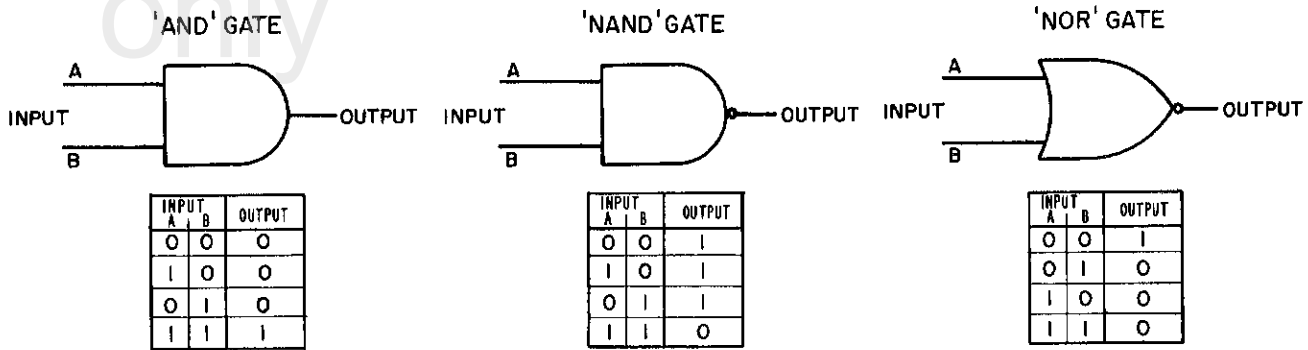
- E. The amplitude of the VCO pulse train output from Q104 varies between 0 volts on negative transitions to 4 volts p-p (minimum) on positive transitions. VCO pulses are applied to gate pin 4 and clock pin 6 inputs of counter U103. VCO pulses are also applied to the gate inputs pin 4 of counters U104 and U105 and the input pin 13 of "Nand" gate U107A.
- F. Refer to figure 2-4. The counting process begins with counter U103. Assume that a sample frequency of 1094 kHz is dialed in, the VCO must operate 140 kHz above this frequency so the programmable counters are preset to 1234 kHz.
- G. Logic states that are applied to the inputs P8, P4, P2 and P1 of counter U103 represent the decimal equivalent number 4. With the number 4 on its inputs it will take 4 VCO pulses to zero counter U103. A down count of one from 4 occurs on each negative transition of the VCO pulse. When the counter reaches 0 it will recycle to the number 9 on the next pulse, and start down counting. U103 does not recycle to its preset state because the reset pulse terminal (pin 12) is grounded by the low level on the reset pulse terminals (pin 12) of U104 and U105.
- H. The counting down and recycling of counter U103 will continue until a reset pulse is applied to pin 12. Each time the counter recycles from 0 to 9 the clock output (pin 1) will go high. A clock pulse is generated and counter U104 is clocked or counts down by 1 from the preset number 3 on its inputs P8, P4, P2 and P1. The counting action of U103 continues and each time the counter goes from 0 to 9 after counting down from 9, counter U104 is clocked 1 time. After counter U104 is clocked 3 times it will be at 0. It will then recycle to 9 and generate a clock pulse to counter U105 on the next VCO pulse. U104 cannot recycle to the preset state until the low level on the reset pulse terminal (pin 12) of U105 goes to a high level. The first 4 input pulses to U103 produce a clock input to U104. Thereafter every 10 input pulses to U103 produces a clock input to U104. For U104 to be counted down to 0 from 3 it therefore takes 24 input pulses to U103.
- I. Counter U105 has the number 2 preset on its inputs P8, P4, P2 and P1. After being clocked 2 times it will recycle from 0 to 9 and deliver a clock pulse to the input pin 11 of type D flip-flop U106B. U105 cannot recycle to the preset state until the low level on pin 13 of NAND gate U111D goes high which occurs after U105 has recycled. The 2 input clocks to U105 are produced after 124 input pulses to U103.

SECTION II
DETAILED CIRCUIT DESCRIPTION



M2042056

Programmable Counter Block Diagram
Figure 2-4



Note:
LOGIC 0 = LO (GROUND)
LOGIC 1 = HI ($\approx +2.5$ VDC)

Logic Truth Tables
Figure 2-5

SECTION II
DETAILED CIRCUIT DESCRIPTION

- J. The \bar{Q} output of U106B goes low when clocked by U105, however, since U105 has already recycled the output of NAND gate U111D is held low by the reset pulse terminal of U105. U105 must therefore count down to 0 once again. In turn, this means U104 must count down to 0 ten times and U103 must count down to 0 110 times. This process requires an additional 1110 input pulses to U103. At this point (1234 pulses) pin 13 of U111D and the reset pulse terminals of U103, U104, and U105 are all at the high level; an output pulse is delivered to the phase detector. The division ratio of the programmable counter is 1234 to 1.
- K. When 1094 is dialed up on the frequency selector, to obtain one reset pulse out of the programmable counter, it requires 1234 pulses from the VCO. If the VCO pulse period for example, was equal to one microsecond (frequency equals 1 MHz) it would take 1234 microseconds or 1.234 milliseconds to generate one reset pulse. Therefore, the period (P_r) of the reset pulse from the programmable counter is equal to 1.234 milliseconds when the VCO period is 1 microsecond (frequency of 1 MHz).

2.11. 1.000 kHz CRYSTAL CONTROLLED CLOCK

- A. The tuning operation of the 201F ADF receiver requires the generation of a frequency and time standard. The crystal controlled clock establishes the frequency stability of the voltage controlled oscillator (VCO). Within the circuit a 256.000 kHz signal is generated and divided down to a 1.000 kHz pulse train. The period (P_r) of these pulses is 1 millisecond and the duty cycle is 50%.
- B. The oscillator is a classic Pierce circuit operating at the crystal (Y101) frequency of 256.000 kHz in a parallel crystal feedback mode. Resistors R104, R103, R101 and R102 form a voltage-divider for positive base bias on Q101. The collector is connected to the 8.2 vdc regulated line through resistors R103 and R104. Capacitor C101 provides the proper regenerative feedback for Q101.
- C. The triangular output waveshape of Q101 is coupled to the base of buffer amplifier transistor Q102 through coupling capacitor C102 and resistor R106. A voltage-divider consisting of resistors R111 and R107 provides positive bias for the collector and base junctions of Q102. The emitter of Q102 is connected to chassis ground.

SECTION II
DETAILED CIRCUIT DESCRIPTION

- D. The output of Q102 is directly coupled to integrated circuit (IC) U101. IC U101 is a TTL divide by 16 counter. The counter will divide the input frequency of 256.000 kHz by 16. An output frequency of 16 kHz is applied to the next counter U102. IC U102 is also a divide by 16 counter. Therefore, the 16 kHz input signal to U102 is further divided down to 1 kHz. This output is applied to the phase detector (pin 1) as the 1 kHz clock signal (F_{rc}).

2.12. PHASE DETECTOR

- A. Phase detector integrated circuit (IC) U115 is a digital frequency/phase detector which includes a digital detector, a pulse amplifier/limiter, and a Darlington coupled transistor pair. Transistor Q105 and the Darlington coupled transistor pair form a high impedance Darlington coupled transistor trio. This high impedance amplifier circuit is used for integration of the pulses from the pulse amplifier/limiter section of U115. Transistors Q106 and Q107 are buffer amplifiers that raise the DC tuning voltage to the proper level for application to the VCO and r-f varicap diodes.
- B. The signal from the 1.000 kHz reference clock (F_{rc}) is a continuous train of pulses spaced 1 millisecond and is applied to terminal 1 of IC U115. The output of the programmable counter (F_r) is also a train of pulses whose spacing or period (P_r) is a function of the following equation:

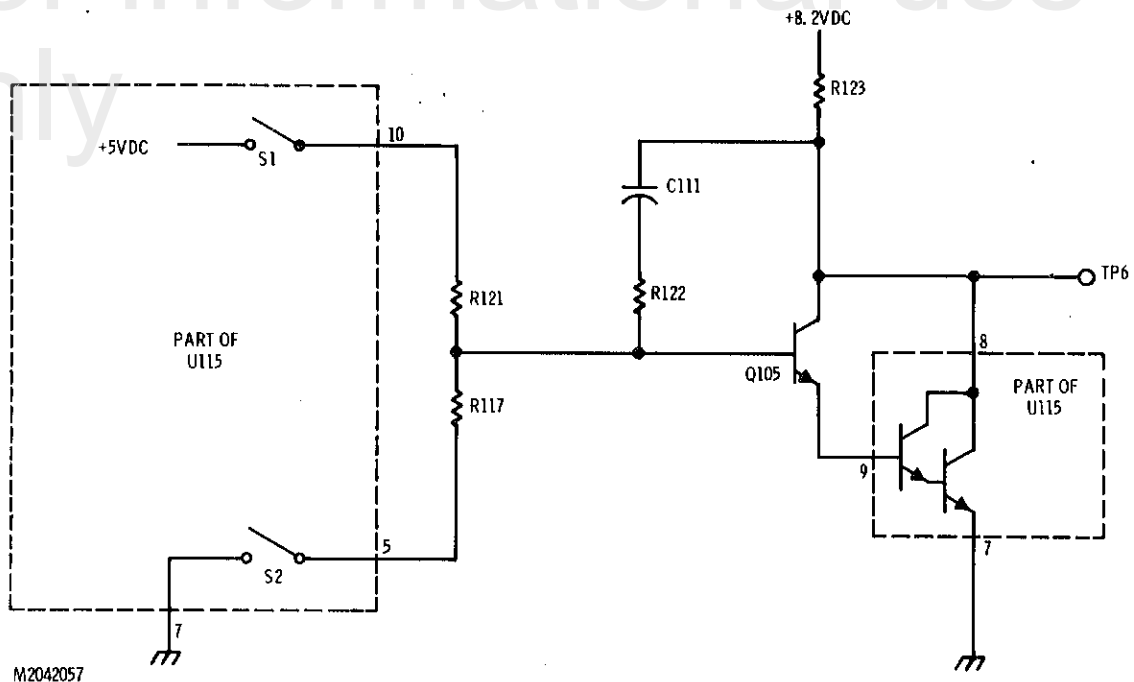
$$\text{(Period) } P_r = \frac{N+140}{F_{vco}}$$

N is the number dialed up in the frequency selector and F_{vco} is the frequency of the VCO. In a locked condition the period (P_r) of these pulses as measured from trailing edge to trailing edge is equal to 1 millisecond. This pulse train is applied to terminal 3 of IC U115.

- C. When the trailing edges of the input F_r and F_{rc} pulses are equal in frequency and phase, the phase detector is in lock and both outputs (pin 2 and pin 13) to the pulse amplifier/limiter section are high. The outputs from the pulse amplifier/limiter (pins 10 and 5) are isolated by reverse-biasing of internal transistor junctions.

SECTION II
DETAILED CIRCUIT DESCRIPTION

- D. When the trailing edges of the input F_r and F_{rc} pulses are not equal either in frequency or phase, negative-going pulses are produced on pin 13 ($F_r < F_{rc}$) or on pin 2 ($F_r > F_{rc}$). Negative-going pulses on pin 13 cause pin 5 of the pulse amplifier/limiter section to connect to ground. Negative-going pulses on pin 2 cause pin 10 of the pulse amplifier/limiter section to connect to +5 vdc.
- E. Refer to figure 2-6, a simplified schematic of the integration circuit for deriving the tuning voltage. S1 and S2 are simplified representations of the pulse amplifier/limiter section of U115 (see paragraph D. and E.). When the reference frequency and the variable signals are equal in frequency and phase, S1 and S2 are both off. The voltage at TP6 is determined by the charge stored on C111. Tuning voltage to the VCO is produced by amplification of the voltage at TP6. As C111 discharges due to leakage, the voltage at TP6 will begin to drop and the VCO frequency will begin to drop. This produces a few negative-going pulses from the phase discriminator which momentarily close S2 contacts. C111 is then charged through R123, R122, and R117 to ground. With C111 recharging the voltage at TP6 rises, the VCO frequency increases, and S2 opens again when the VCO is at the correct frequency. If the VCO frequency would drift higher in frequency for some reason, negative going pulses from the phase discriminator would momentarily close S1. This would cause C111 to discharge slightly which in turn would cause the voltage at TP6 to drop, the VCO to decrease in frequency, and S1 to open when the VCO returned to the correct frequency.



Tuning Voltage Integration Circuit,
Simplified Schematic Diagram
Figure 2-6

SECTION II
DETAILED CIRCUIT DESCRIPTION

- F. The d-c output voltage from Q105 varies between 1.8 and 5 vdc depending on the frequency selected. This output is applied to the base of buffer amplifier transistor Q106 through coupling resistor R124.
- G. Buffer amplifiers Q106 and Q107 increase the range of the d-c output voltage from Q105. The d-c output voltage from the collector of Q107 is the tuning voltage, and is used to tune the VCO and receiver tuned circuits. Ranging from 1.25 vdc for low frequencies, the tuning voltage will increase exponentially to 6.5 vdc for high frequencies within each band selected. Therefore, an increase in tuning voltage causes a corresponding increase in the frequency of the VCO and of the receiver tuned circuits resonance.
- H. The positive 8.2 vdc regulator consists of an 8.2 vdc zener diode CR114, filter capacitor C117 and current limiting resistor R156. One end of resistor R156 is connected to the 9.1 vdc regulated line and the other end to CR114.
- I. The collectors of Q106 and Q107 are connected to the 8.2 vdc line through resistors R127 and R132 respectively. Base bias for Q106 is established by the divider consisting of resistors R125 and R126.
- J. Zener diode CR116 and resistor R163 drop the 8.2 vdc down to 5.1 vdc. This voltage supplies transistor Q105 and the output circuitry of IC U115.

2.13. FREQUENCY SELECTION

- A. The digital frequency selectors located on the front panel control the digital tuning logic inputs and display the selected frequency. The frequency selector consists of four internally illuminated thumbwheel switches.
- B. To generate the 140.0 kHz intermediate frequency (i-f) the voltage controlled oscillator (VCO) must operate 140.0 kHz above the incoming r-f signal. The internal design of the frequency selector switches is such that the 10 kHz BCD information is automatically advanced 40 kHz. Thus a selected frequency of 1000 kHz is advanced to 1140 kHz.

SECTION II
DETAILED CIRCUIT DESCRIPTION

C. 100 kHz BCD information must be offset to one of two possible values; these are plus 100 kHz and plus 200 kHz. The reason for two values is explained in the following examples:

(1) If the selected frequency is 1000 kHz, the offset frequency is 1140 kHz. The 100 kHz BCD information is advanced by 1.

(2) If the selected frequency is 1060 kHz, the offset frequency is 1200 kHz. The 100 kHz BCD information is advanced by 2.

The front panel 100 kHz selector switch automatically produces both an advanced by 1 (1, 2, 3, 4) and an advanced by 2 (1', 2', 4', 8') BCD output. Selection of either the advanced by 1 or advanced by two BCD information is performed by the offset data selection circuitry (refer to paragraph 2-14A). The offset data selection circuitry is controlled by the 10 kHz carry signal (C_{10}) which is generated by the 10 kHz frequency selector switch whenever the selected 10 kHz frequency is greater than 60 kHz.

D. A similar operation is initiated in the generation of the 1 MHz offset BCD information. In this case, when the selected frequency is 800 or 900 kHz the 100 kHz carry signal (C_{100}) causes the offset data selection circuitry to advance the 1 MHz BCD information. An example of this is as follows.

800 kHz + 140 kHz = 940 kHz

No 100 kHz carry (C_{100}) present.

860 kHz + 140 kHz = 1000 kHz

100 kHz carry (C_{100}) present

900 kHz + 140 kHz = 1040 kHz

100 kHz carry (C_{100}) present

E. 1 kHz BCD information is not advanced.

SECTION II
DETAILED CIRCUIT DESCRIPTION

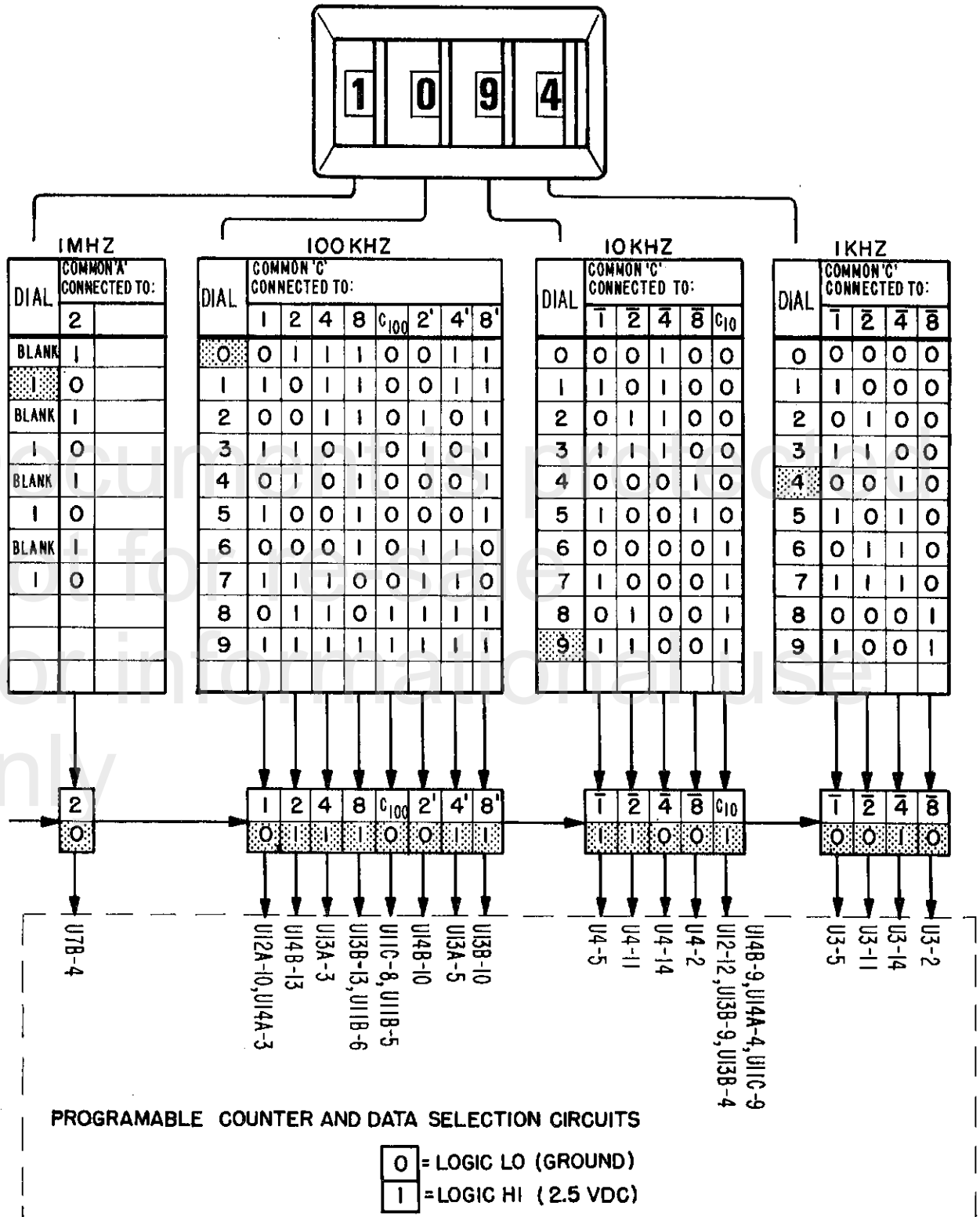
2.14. DIGITAL FREQUENCY SELECTORS

- A. The logic information from the 1 kHz and 10 kHz switches is inverted BCD. Information from the 100 kHz and 1 MHz switches is straight BCD. Inversion for the 100 kHz and 1 MHz logic information takes place in the data selection circuitry before being applied to counters U105 and U106B.
- B. Refer to figures 2-4 and 2-5 and the receiver synthesizer schematic (figure 6-1) for the following discussion. To help understand the flow of logic information and how to use the charts and diagrams a sample frequency will be dialed in and the resultant logic conditions will be followed through the digital circuitry.
- C. In figure 2-6A the sample frequency of 1094 kHz is dialed in. Starting with the 1 kHz switch and reading across from the dial number 4, the logic outputs for pins $\bar{1}$, $\bar{2}$, $\bar{4}$, $\bar{8}$ equal 0, 0, 1, 0 respectively. Moving to the 10 kHz switch and reading across from the dial number 9, we get the logic outputs for pins $\bar{1}$, $\bar{2}$, $\bar{4}$, $\bar{8}$, C_{10} equal to 1, 1, 0, 0, 1 respectively.
- D. Next, in the 100 kHz switch, we read across from the dial number 0. The logic output for pins 1, 2, 4, 8, C_{100} , 2', 4', 8' is equal to 0, 1, 1, 1, 0, 0, 1, 1 respectively.
- E. Last is the 1 MHz switch. Reading across from the dial number 1, the logic output for pin 2 is equal to a logic 0.
- F. The logic information from the 1 kHz switch is applied directly to the counter inputs of U103. Logic information from the 10 kHz module, with the exception of the C_{10} output, is applied directly to the counter inputs of U104. C_{10} indicates a carry out of the 10 kHz switch. This output, which is applied to the data selection circuitry, is a logic 1 when dial numbers 6 through 9 are selected.

2.14a OFFSET DATA SELECTION CIRCUITRY

- A. The data selection circuitry accepts the logic information from the 10 kHz carry (C_{10}) output of the 10 kHz switch and the logic outputs from the 100 kHz and 1 MHz switches. When frequencies are dialed in, the offset data selection circuitry provides the proper logic information to counter inputs of U105 and Type D flip-flop U106B.

SECTION II
DETAILED CIRCUIT DESCRIPTION



Frequency Selector, Logic Truth Tables

Figure 2-6A

SECTION II
DETAILED CIRCUIT DESCRIPTION

- B. As an example of offset data selection, refer to the 8 (advanced by 1 output) and 8' (advanced by 2) outputs from the 100 kHz switch module that are shown in sheet 2 of figure 6-1. The C_{10} output from the 10 kHz switch module is applied to one AND gate of U113B (pin 9). The inverted C10 output from NAND gate U112D pin 11 is applied to the other AND gate of U113B (pin 1). With this arrangement, a logic 0 always appears at one input of one AND gate, therefore one of the two AND gates is always disabled. The AND gate that is not disabled drives the NOR gate section of U113B to the level opposite the data input (8 or 8') level of the enabled AND gate. If C_{10} is a logic 1 the level at U113B is a logic 0 and that AND gate section is disabled. Pin 9 of U113B is a logic 1, so that AND gate is enabled. Therefore, if 8 is a logic 1, the input to the NOR section of U113B is a logic 1 and the output of U113B at pin 8 is a logic 0. If 8' is a logic 0, the input to the NOR section of U113B is a logic 0 and the output of U113B is a logic 1.
- C. Selection of the other advanced by 1 or advanced by 2 data (4, 2, 1 or 4', 2', 1') is done in the same manner as selection of 8 or 8'.
- C. The logic conditions on the inputs to the data selection circuitry have been established for the sample frequency of 1094 kHz in figures 2-4 and 2-6. With the use of the truth tables in figure 2-5 the output of "Nor" gates U113A, B, U114A, B, and "Nand" gate U107B can be determined.
- E. The logic information from "Nor" gates U113A, B pins 8 and 6 and U114A, B pins 8 and 6 is applied directly to the counter inputs P8, P4, P2, P1, and is equal to 0, 0, 1, 0 respectively.
- F. The logic information from "Nand" gate U107B pin 6 is applied directly to the input pin 11 of "Nand" gate U107C and preset pin 10 of Type D flip-flop U106B. The logic condition at these two inputs is equal to "1".

2-15. MONITOR (MON)

- A. The monitor light on the front panel provides the pilot with a visual indication of the tuning conditions within the receiver. When illuminated the light indicates that the receiver is not tuned properly. This may be caused by selecting a frequency above or below the frequency range of the band selector or in the event a malfunction has occurred with the receiver.

These malfunctions are as follows:

1. When VCO or programmable counter fails.
2. When 1 kHz reference clock fails in a low state.

SECTION II
DETAILED CIRCUIT DESCRIPTION

2-15.

- B. The monitor circuit consists of, lamp DS5, lamp drivers Q111 and Q112 and type D flip-flop U106A which is used as a coincidence detector. Pulses from the 1 kHz reference clock are inputted to terminal 3 of flip-flop U106A. Reset pulses from the programmable counter are inputted to terminal 2. When the leading edges of the reference clock pulse and the reset pulses from the programmable counter are not equal in frequency and phase synchronization (out of lock), the \bar{Q} output of U106A will go high. With a high condition on \bar{Q} output, transistors Q111 and Q112 will "turn on".
- C. Lamp DS5 is connected at one end to the 14 vdc line and the other end is connected to the collectors of transistors Q111 and Q112. When transistors Q111 and Q112 turn on the path to ground is completed for lamp DS5 and the lamp will glow. Resistor R134 and capacitor C116 determine the response time of transistors Q111 and Q112.

2-16. BEAT FREQUENCY OSCILLATOR

- A. The beat frequency oscillator (BFO) enables the receiver to generate a 1000 Hz tone when receiving type A0 and type A1 signals. The BFO consists of the following circuits: coupling circuits R146 and C123, circuit R145 and C113, "nand" gate U112A, a voltage divider R151, R152, and pin 1 of switch S7. Operation of the BFO circuit is as follows. When the function switch 27 is placed in the BFO position 9.1 VDC is applied to voltage divider R151 and R152. Pin 2 input of "nand" gate U112A will change from a low condition (logic 0) to a high condition (logic 1).
- B. Pulses from the 1 kHz reference clock are applied to input pin 1 of "nand" gate U112A. With no voltage applied to voltage divider R151 and R152 the output of "nand" gate will stay at a logic 1. With each positive clock pulse input the output of U112A will go low (logic 0). The 1 kHz output pulses of U112A are shaped in the form of a sine wave by integrator circuit R145 and C113 and applied to pin 1 of i-f transformer T4 through resistor R146 and capacitor C123. The 1 kHz signal will beat with the incoming 140.0 kHz i-f signal and after detection a 1000 Hz signal will be applied to the audio amplifier.

2-17. 5 VOLT D. C. REGULATOR

- A. The 5 vdc regulator provides a regulated d-c voltage (regardless of load conditions) to the integrated circuits in the synthesizer. 14 vdc from the aircraft bus is applied to the regulator through CR20 and CR21. This voltage is reduced and regulated to 5.0 ± 0.25 volts d-c.

SECTION II

DETAILED CIRCUIT DESCRIPTION

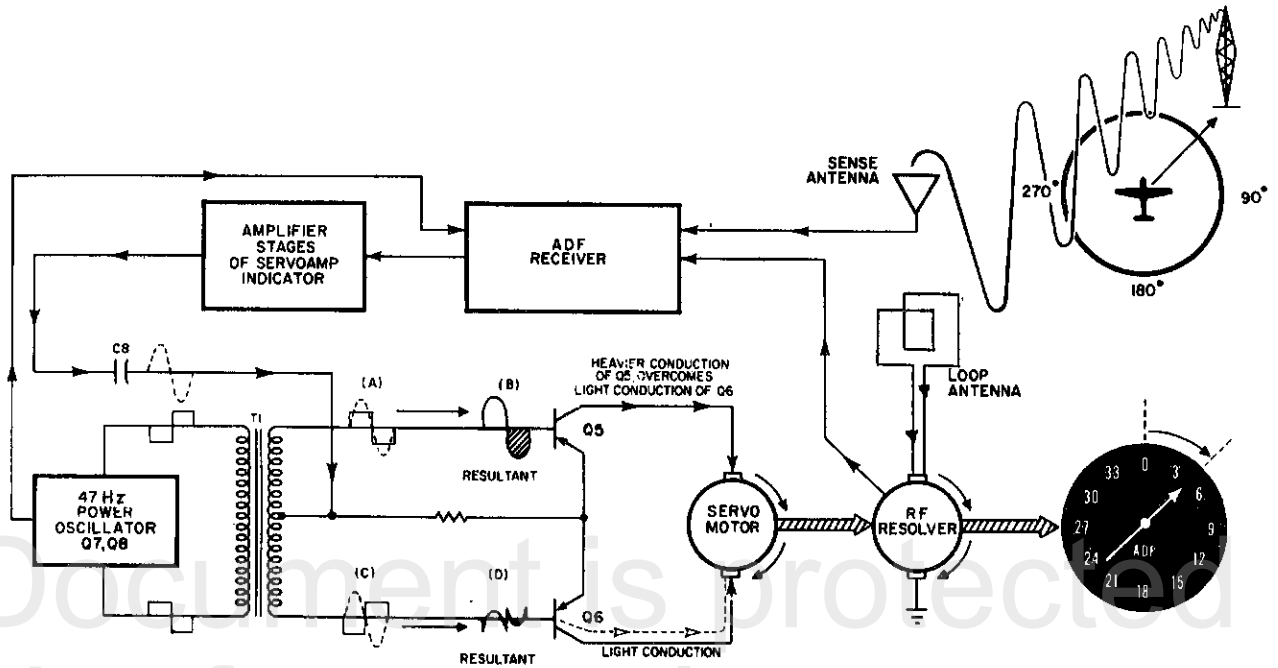
2-17.

- B. Transistors Q115 and Q116 perform as a darlington series pass regulator. Base bias for transistor Q116 is determined by the conduction characteristics of transistor Q117. Base bias for transistor Q117 is obtained from the arm of potentiometer R157. Potentiometer R157 is part of a voltage divider consisting of R157, R142 and R143. This voltage divider is connected across the 5 vdc output line. Adjustment of potentiometer R157 changes the bias level and conduction characteristics of transistor Q117 and therefore provides a means of accurately setting the regulator output voltage.
- C. Zener diode CR115 and resistor R147 establish a 3.3 volt reference for the emitter of transistor Q117. Capacitors C121 and C122 by-pass any a-c component riding on the d-c to ground.

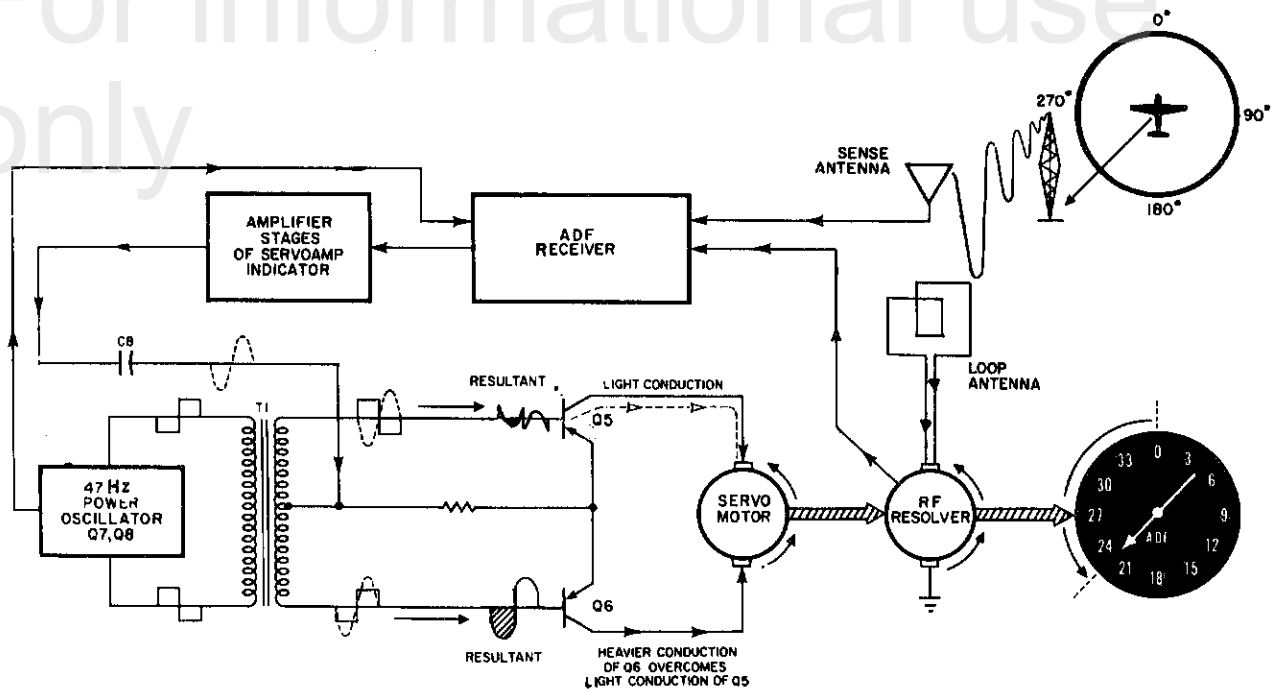
2-18. MOTOR CONTROL AMPLIFIER (figure 6-3)

- A. The motor control amplifier stage consists essentially of transistors Q5 Q6, the secondary winding of transformer T-1, a low-pass filter network and the d-c servo motor.
- B. The purpose of the motor control amplifier is to amplify and compare the relative phase and amplitudes of both the 47 Hz power oscillator reference voltage and the incoming 47 Hz variable ADF voltage. This is necessary in order to arrive at a resultant voltage that will control the direction of rotation of the servo motor. Consequently, this will enable the r-f resolver rotor coil to stop rotating upon reaching the "true" null position.
- C. The output of the 47 Hz power oscillator is applied to the input of the motor control amplifier through the secondary winding of transformer T-1 (See Figure 2-7). As a result, a square-wave signal exists at the bases of transistors Q5 and Q6 that are 180 degrees out-of-phase due to the center-tapped secondary winding of transformer T1. The two signals are of equal amplitude.
- D. The recovered ADF signal is coupled through capacitor C8 to the center tap secondary of T1 and applied in-phase to the bases of transistors Q5 and Q6. Therefore, upon receipt of a loop r-f signal, two signals, algebraically added will exist at the bases of transistors Q5 and Q6. One signal being the recovered 47 Hz variable ADF signal from the output of the ADF receiver and the other signal being the 47 Hz. reference output signal from the power oscillator. The ADF variable signal is the same phase at both transistor bases. The power oscillator reference signal is 180 degrees out-of-phase at both transistor bases.
- E. Figure 2-7 illustrates the operation of the circuit when the relative bearing of the aircraft from the station is 45 degrees (right). Figure 2-8 illustrates the operation of the circuit when the relative bearing of the aircraft from the station is 225 degrees (left). Figure 2-9 illustrates the operation of the circuit when the relative bearing of the aircraft from the station is zero degrees; that is, the aircraft pointing directly to the transmitting station.

SECTION II
DETAILED CIRCUIT DESCRIPTION



Motor Control Amplifier Operation (45° Bearing) Simplified Schematic Diagram
Figure 2-7



Motor Control Amplifier Operation (225° Bearing), Simplified Schematic Diagram
Figure 2-8

SECTION II

DETAILED CIRCUIT DESCRIPTION

2-18.

- F. Referring to Figure 2-7 it is indicated by the position of the aircraft in relation to the transmitting station that the ADF indicator pointer should rotate in a clockwise manner and stop at the 45 degrees mark on the calibrated dial.
- G. It will be assumed that the output at the collector of transistor Q5 causes clockwise rotation of the servo motor armature while the output at the collector of transistor Q6 causes counterclockwise rotation of the motor armature.
- H. It will further be assumed, for the sake of clarity, that the amplitude of the 47 Hz oscillator output signal is 5 vac and the amplitude of the ADF signal at the bases of Q5 and Q6 is 10 vac. The incoming ADF signal will either add to the 47 Hz oscillator signal at the base of Q5 and subtract from the 47 Hz oscillator signal at the base of Q6 or vice versa.
- I. Due to the action of the mixed loop r-f and sense r-f signals at the output of the balanced modulator isolation amplifier, the ADF signal (in this case) adds (or aids) the oscillator signal at the base of Q5 and subtracts (or opposes) the oscillator signal at the base of Q6. This is indicated in (a) and (c) of Figure 2-7. The resultant signal derived from the algebraic summation of the two signals is indicated in (b) and (d) of the figure 2-7.
- J. Consequently, during the first half-cycle of the resultant signals (b) and (d), the bases of transistors Q5 and Q6 are positive enough with respect to their emitters to cause a state of reverse-bias in both transistors. In other words, neither transistor is conducting during the first half-cycle of resultant voltage. As a result, there is no output at the collectors of both transistors. Hence, the servo motor armature does not rotate.
- K. During the next half-cycle of resultant voltage (shaded areas), the bases of transistors Q5 and Q6 become negative enough with respect to their emitters so as to cause a state of forward bias in both transistors. In other words, both transistors are conducting during this second half-cycle of resultant voltage.
- L. It will be noted at this time that the base of transistor Q5 is more forward-biased than that of the base of Q6. With our representative values taken into consideration, this means there is a 15 vac signal at the base of Q5 and only a 5 vac signal at the base of Q6. Transistor Q5, being more forward-biased than that of Q6 results in heavier collector current flowing through the clockwise rotation control winding of the motor than that of the counterclockwise control winding applied from the collector output of transistor Q6.

SECTION II

DETAILED CIRCUIT DESCRIPTION

2-18. L.

NOTE

In some cases, the 47 Hz oscillator reference voltage will be at a higher amplitude than the ADF signal. This is dependent upon the relative position of the loop antenna "pickup" with respect to the angle and distance of the transmitting station. Whether the ADF signal is at a higher or lower amplitude than the reference voltage, the motor control amplifier essentially operates the same. The only difference being that when the ADF signal is lower in amplitude than the reference voltage, transistors Q5 and Q6 alternately conduct during each half cycle of resultant voltage. The servo motor responds only to the output developed from the heavier conducting transistor.

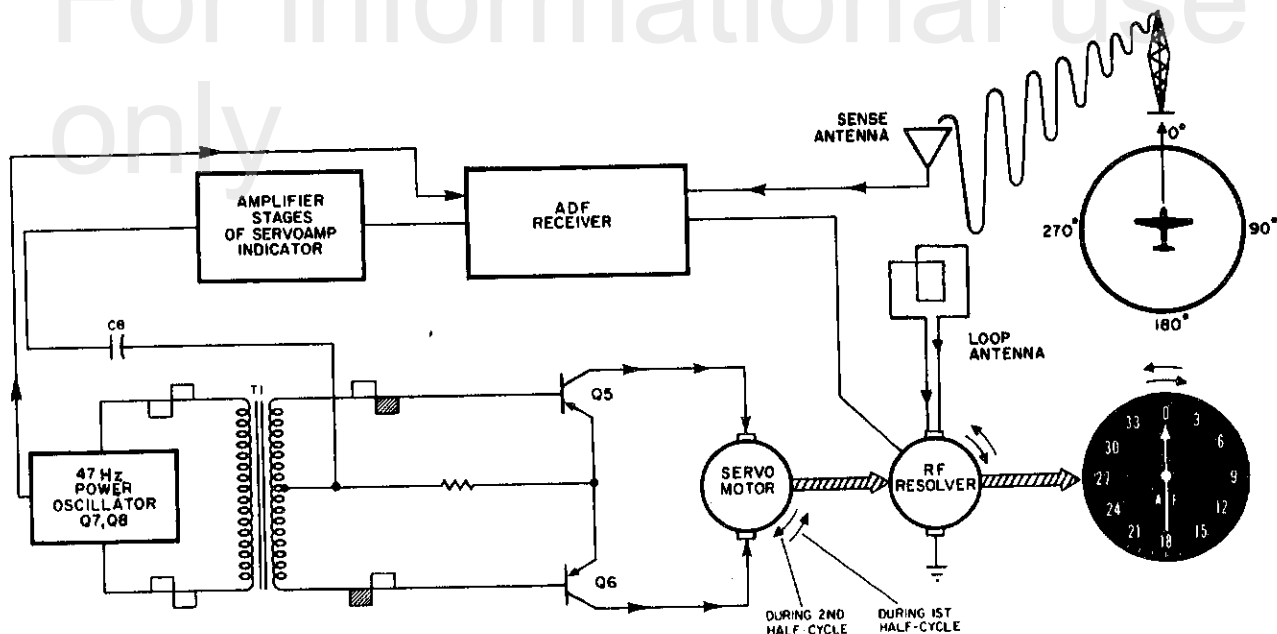
- M. Hence, the motor "sees" only the difference between both collector output currents. Since more current is flowing from the collector output of Q5, the motor responds to this output only and momentarily rotate in a clockwise direction.
- N. As explained previously, the servo motor, mechanically linked to the r-f resolver rotor, causes the resolver rotor coil to also rotate in a clockwise manner. This in turn, decreases the mutual inductance between the rotor coil magnetic field and the field surrounding the stator coils, until a point of zero voltage at the resolver output is attained, at which time the system is at "null".
- O. Consequently, the variable 47 Hz ADF signal is absent at the bases of transistors Q5 and Q6. Hence, the motor stops rotating and the resolver rotor coil stops rotating at a position that is 45 degrees relative to the stator coils. The ADF pointer, mechanically coupled to the r-f resolver rotor shaft also stops rotating at the 45 degree indication on the calibrated dial.
- P. In effect, the ADF pointer is representative of the r-f resolver rotor coil and the calibrated dial is representative of the stator coils. The effected result as observed on the indicator is the angular relationship of the resolver rotor coil with respect to the stator coils. This in turn, is representative of the aircraft's bearing from the transmitting station.
- Q. Figure 2-8 illustrates the aircraft in a position of 225 degrees bearing relative to the transmitting station. In this case, it is required that the servo motor armature must rotate counterclockwise enabling the r-f resolver rotor coil to stop at the 225 degree angle ("true" null).
- R. The circuit operates identically to that shown in Figure 2-7 except that the ADF variable signal is reversed in phase. Consequently, transistor Q6 conducts heavier during the negative half-cycles of resultant voltage. Hence, the servo motor armature rotates in a counterclockwise direction.

SECTION II

DETAILED CIRCUIT DESCRIPTION

2-18.

- S. Figure 2-9 illustrates the aircraft pointing to the station or with a relative bearing of zero degrees. When this condition exists, only the 47 Hz oscillator reference voltage appears at the bases of transistors Q5 and Q6. This is due to the absence of the loop r-f "error" signal to the input of the receiver. In other words, the ADF System is "nulled" out.
- T. During the first half-cycle of oscillator "switching" voltage, the base of transistor Q5 becomes more positive with respect to the emitter while the base of Q6 becomes more negative. As a result, transistor Q5 is "shut-off" (or non-conducting) while transistor Q6 is forward biased into a state of conduction. The output from the collector of Q6 (during the first half-cycle) causes the servo motor armature to rotate counterclockwise until the next half-cycle appears at the bases of both transistors. During this next half-cycle of oscillator switching voltage, a reverse action is initiated. That is, transistor Q5 becomes forward biased while transistor Q6 is "shut off". The collector output of Q5 tends to drive the motor armature in a clockwise direction.
- U. Consequently, for a complete cycle of oscillator voltage (with the absence of an ADF loop r-f signal), the servo motor armature effectively "swings" back and forth as if vibrating. The repetition rate is so fast that if observed by the naked eye, the armature would appear to be standing still or not rotating at all. As a result, the indicator pointer is observed as simply a zero or "on course" indication against the fixed calibration dial.



Motor Control Amplifier Operation (Zero Degrees Bearing), Simplified Schematic Diagram
Figure 2-9

SECTION III
MAINTENANCE PRACTICES

3-1. GENERAL

- A. This section of the manual contains information and procedures for performing tests and adjustments together with corrective and preventive maintenance of the ADF-T12D system.

3-2. ADJUSTMENTS/TESTS

A. JOB/USE

- (1) The alignment procedures detailed in this section of the manual are performed to adjust the system for optimum performance. The performance tests detailed in the following paragraphs will determine whether the system meets the minimum performance requirements.

NOTE: Perform all alignment procedures in the order listed.

B. TEST EQUIPMENT REQUIRED

- (1) The test equipment (or equivalent) required to perform the procedures detailed in the following paragraphs are listed in table 3-1. The basic system test set-up required to perform these procedures is illustrated in figure 3-2. Instructions for connecting additional equipment are included in the specific procedures as required.

TEST EQUIPMENT

TABLE 3-1

REPRESENTATIVE TYPE	NAME OF EQUIPMENT	PURPOSE OF EQUIPMENT
Hewlett Packard Model 606C	R-F Signal Generator	To simulate loop and sense r-f signals for application to receiver input for alignment purposes.
Hewlett Packard Model 200AB	A-F Signal Generator	Used to modulate r-f signal generator and for checking power oscillator.
Hewlett Packard 130C	Oscilloscope	Used to visually check voltage waveforms during specific tests and adjustments.
Triplet Model 630	Multimeter	Used to check voltage and resistance of circuits where required.
Hewlett Packard Model 400D	AC VTVM	Used to measure r-f and a-f voltages.

SECTION III
MAINTENANCE PRACTICES

3-2. B. (1)

Table 3-1 (Continued)

REPRESENTATIVE TYPE	NAME OF EQUIPMENT	PURPOSE OF EQUIPMENT
General Radio Model 583A	Output Power Meter	Used to measure output power.
Perkin Model MR532-15A	Power Supply	Provide primary d-c power to system. 14 vdc 1 amp 28 vdc
Bendix, P/N 2V005 and 2V009	System interconnect cable and loop line	Used to interconnect all components of system for bench test purposes.
---	Standard test sense antenna.	Simulate sense antenna during tests. See Figure 3-1.
Ace Mfg. Co., Philadelphia, Pa.	Screen Room (FAA Approved)	Shielded room necessary to adequately test and adjust system in ADF mode of operation. See para. 3-2. C.
General Radio Type 1192	Frequency Counter	Used to check operation of digital tuning logic.
John Fluke Model 8100A	Digital Voltmeter (Min. 0.1% Accuracy)	Used to check and adjust VCO operating voltages.

C. SCREEN ROOM

- (1) All tests performed on the system in the ADF mode of operation must be performed in a screen or shielded room so as to accurately simulate the conditions under which the loop antenna and associated circuits would operate in a free-space, radiated signal field. If a screen room is not available, the TIC, Model CES-116A ADF Signal Simulator or equivalent must be utilized for testing the system. Refer to manufacturers Instruction Manuals for proper use of ADF Signal Simulators.

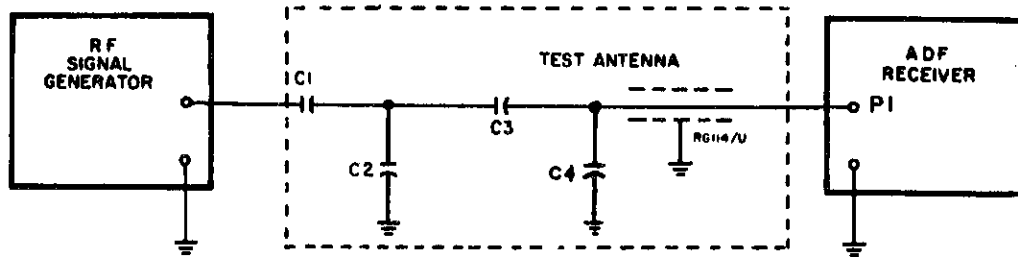
D. STANDARD TEST SENSE ANTENNA

- (1) A standard 1/2 meter test sense antenna must be constructed and used when testing and aligning the ADF-T12D in an FAA approved screen room.

SECTION III
MAINTENANCE PRACTICES

3-2.D.

- (2) Construct the test antenna as follows:



Standard Test Sense Antenna Connection
Figure 3-1

- C1 = 1100 pf
C2 = 10,000 pf
C3 = 39 pf
C4 = 82 pf (total capacitance of both
C4 and RG/114U cable.
RG/114U is nominally 6.5
pf/foot.)
P1 = PL259

NOTE

The above values simulate a 1/2 meter sense antenna in an average size screen room that has an attenuation room factor of 5:1. For a screen room with a 10:1 factor, change capacitor C1 to 560 pf.

E. RECEIVER ALIGNMENT (Figure 3-2, 3-3 and 3-4)

- (1) I-f alignment

- (a) Remove the dust cover and assemble the ADF-T12D system as indicated in figure 3-2. Inject signal at mixer coil L7 pin 4 (I. F. Test).

NOTE

Make certain the 14/28 vdc selector switch located at rear of receiver corresponds to the selected input voltage from the power supply.

SECTION III
MAINTENANCE PRACTICES

- (b) Apply power to all equipment and allow 15 minutes for test equipment to warm up.
- (c) Verify with multimeter that the d-c voltage between pins 15 and 9 of connector J1 is $13.75 \pm 5\%$ vdc (for 14 vdc operation) or $27.5 \pm 5\%$ vdc (for 28 vdc operation).
- (d) Adjust the r-f signal generator to 140.0 kHz. Signal generator frequency should be set to within 50 Hz. Use frequency counter to check generator. Modulate the generator signal 30% at 400 Hz.
- (e) Set the receiver function switch to REC.
- (f) Set the receiver band switch to 200-400 position.
- (g) Dial up 400 kHz on the frequency selectors.

NOTE

When the receiver is set to a specific frequency the monitor lamp will go out indicating proper tuning. If difficulty is experienced in tuning the receiver and/or the monitor lamp fails to go out, do not attempt to align the receiver. Refer to the troubleshooting section and correct the malfunction, then proceed with the alignment procedure.

- (h) Adjust the output of the r-f signal generator until a mid-scale deflection is obtained on the tuning meter.

NOTE

Steps (i) and (j) must be performed with extreme care so that the selectivity requirements of paragraph 3-2.H.3. can be met.

- (i) Adjust the tuning cores of the i-f transformers for maximum indication on the tuning meter. Adjust in the following order: T5, T4, T3. Primaries are top-side and secondaries are bottom. The primary of each transformer is adjusted first, the secondary second. Reduce the generator output as necessary to maintain mid-scale deflection on the tuning meter.
- (j) Set the volume control to the middle of it's rotation. Tune T6 for maximum audio output on the output power meter.
- (k) Remove signal generator input to coil L7.

SECTION III
MAINTENANCE PRACTICES

3-2.E.

(2) Voltage Controlled Oscillator (VCO) Alignment

(a) Tuning Voltage Adjustments

On units bearing serial numbers 2190 and above a Band-End-Tuning-Voltage decal is installed on the top of the synthesizer shield assembly (see figure 3-4). This decal specifies the low frequency end and the high frequency end tuning voltages for the three bands. These voltages are to be used when aligning the VCO.

For units bearing serial numbers lower than 2190 use 1.25 ± 0.1 VDC for the low end and 6.5 ± 0.2 VDC for the high end of each band.

- (1) Connect the digital voltmeter to TP3 (see figure 3-4) and set to the 10 volt range.
- (2) Place the receiver function switch to the REC position and the band switch to 200-400. Allow test equipment and receiver to warm up for 15 minutes.
- (3) Dial up 200 kHz in the frequency selector. Note that the monitor light goes out.
- (4) Adjust L10 for the low end tuning voltage ± 0.1 VDC specified on the Band End Tuning voltage decal.
- (5) Dial up 400 kHz and adjust C39 for the high end tuning voltage ± 0.2 VDC specified. Repeat steps (2) through (5) until no further improvement can be made.
- (6) Position the band switch to 400-800.
- (7) Adjust L11 for the low end tuning voltage ± 0.1 VDC specified.
- (8) Dial up 800 kHz and adjust C41 for the high end tuning voltage ± 0.2 VDC specified. Repeat steps (7) and (8) until no further improvement can be made.
- (9) Position the bandswitch to 800-1600 and adjust L12 for the low end tuning voltage ± 0.1 VDC specified.
- (10) Dial up 1600 kHz and adjust C43 for the high end tuning voltage ± 0.2 VDC specified. Repeat steps (9) and (10) until no further improvement can be made.

SECTION III

MAINTENANCE PRACTICES

3-2. E. (2)(b)(5)

(b) VCO Injection Voltage Adjustments

- (1) Connect the AC VTVM to TP4. (refer to figure 3-4).
- (2) Place the receiver function switch in the REC position and the band switch to 200-400.
- (3) Dial up 200 kHz and adjust feedback potentiometer R87 for a 0.120 vac reading on the AC VTVM.
- (4) Dial up 400 kHz and note that the voltage reading is 0.120 minimum.
- (5) Check the voltage levels on bands II and III.

<u>VOLTAGE</u>	
Band II	
400 kHz - - -	0.150 vac minimum
800 kHz - - -	0.150 vac minimum
Band III	
800 kHz - - -	0.200 vac minimum
1600 kHz - - -	0.200 vac minimum

(3) R-F Alignment

- (a) Connect the r-f signal generator through the "dummy" test antenna to terminal 1 of connector J1. Refer to figure 3-2.
- (b) Place the receiver function switch in the REC position and dial up 200 kHz in the frequency selector.
- (c) Adjust the signal generator for a peak on the tuning meter at 200 kHz.
- (d) Adjust the output of the signal generator until a mid-scale reading is obtained on the tuning meter.
- (e) Adjust the tuning cores of mixer coil L7 and r-f coil L4 (in this order), for maximum indication on the tuning meter. Lower the output of the signal generator as found necessary to maintain a mid-scale reading on the tuning meter.
- (f) Dial up 400 kHz in the frequency selector.
- (g) Adjust the signal generator for a peak on the tuning meter at 400 kHz.
- (h) Adjust trimmer capacitors C24 and C22 (in this order), for maximum indication on the tuning meter.
- (i) Repeat steps (b) through (h) as follows on bands 2 and 3. Maintain mid-scale reading on the tuning meter during adjustments, and repeat steps (b) through (h) until no further improvement can be made.

SECTION III

MAINTENANCE PRACTICES

3-2. E. (3)(1)

In each case always make the last adjustment with the trimmer capacitor.

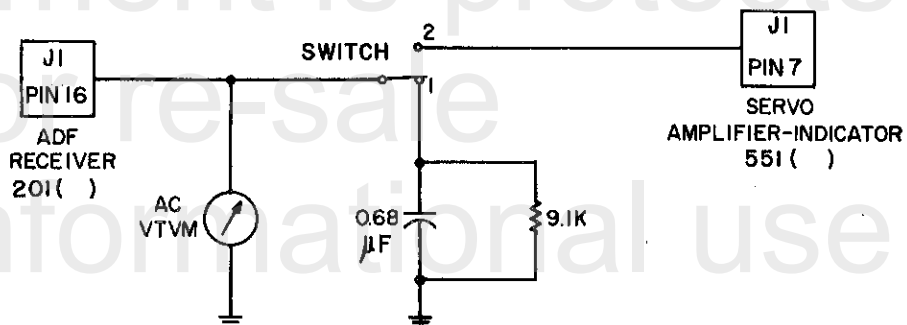
- | | |
|---------|--------------------------------|
| Band 2: | 400 kHz - Adjust L8 and L9 |
| | 800 kHz - Adjust C26 and C17. |
| Band 3: | 800 kHz - Adjust L9 and L6 |
| | 1600 kHz - Adjust C28 and C19. |

(4) Loop Stage Alignment

- (a) Set the receiver function switch to the ADF position.
- (b) Set the receiver band selector to the 200-400 position.

NOTE

Servo motor must not rotate while aligning loop stages. Do not attempt to retard motor by holding or clamping. The recommended method of stopping the motor is as follows:



Loop Alignment
Figure 3-5

(During loop alignment, switch must be in position 1.)

- (c) Dial up 200 kHz in the frequency selector.
- (d) Adjust the signal generator for a peak at 200 kHz. Manually rotate the fixed loop through 90 degrees for a maximum indication on the VTVM.

NOTE

Tune for a peak reading on tuning meter. Reduce output of signal generator (if necessary) to maintain a Mid-scale reading on tuning meter, always make the the last adjustment with the trimmer capacitor.

- (e) Adjust the tuning core of coil L1 for maximum indication on VTVM connected to J1 pin 16.
- (f) Adjust the receiver and signal generator to 400 kHz.

SECTION III

MAINTENANCE PRACTICES

3-2. E. (4)

- (g) Adjust trimmer capacitor C3 for maximum indication on VTVM.
- (h) Repeat steps (c) through (g) until no further improvement can be obtained.
- (i) Repeat steps (b) through (h) for band 2 and 3 as follows:

Band 2: 400 kHz - Adjust L2
 800 kHz - Adjust C4

Band 3: 800 kHz - Adjust L3
 1600 kHz - Adjust C6

- (j) With a scope connected to TP1 (see figure 3-2 and 3-3), a 47 Hz modulated square-wave is to be expected, as shown in figure 3-6. The best modulation percentage is obtained when the loop stage is properly tuned. Modulation between 30% and 100% is typical of the low end of each band and 20% to 100% at the high end of each band.

(5) AGC Adjustment

- (a) Set the receiver function switch to REC position.
- (b) Adjust the signal generator and receiver to 200 kHz.
- (c) Modulate the generator 30% at 400 Hz and adjust for a level of 150 μ v. Set the volume control fully CW.
- (d) Adjust R43 fully clockwise. Note the audio output voltage at the receiver as indicated on the VTVM.
- (e) Adjust AGC control R43 counterclockwise until the audio output voltage at the receiver decreases 4 db as indicated on the VTVM.

(6) Audio Level Adjustment

NOTE

The following procedure adjusts the maximum audio output of the receiver to 32 milliwatts. This level is intended to satisfy most aircraft installation requirements. However, it may be necessary, according to individual aircraft installation requirements, to set the audio output either higher or lower than 32 milliwatts.

- (a) Re-adjust signal generator for 150 μ v output, with frequency and function as in step (5).
- (b) With VOL control adjusted for maximum output (fully clockwise), set audio trimmer potentiometer R51 for an output of 32 mw \pm 5 mw as indicated on the audio output meter. The speaker switch must be off.

SECTION III

MAINTENANCE PRACTICES

3-2. E. (6)

- (c) Turn the function selector switch to OFF and note that the output meter indicates zero.

(7) AGC Performance Check

- (a) Set the receiver and signal generator to 200 kHz. Modulate the signal generator 30% at 400 Hz.
- (b) Set signal generator output to 150 μ volts.
- (c) Set the volume control for 2.0 volts audio output on the Ballantine VTVM.
- (d) Vary the signal generator output from 150 μ volts to 1.5 volts and note that the audio output does not increase more than 10 db nor decrease more than 6 db.

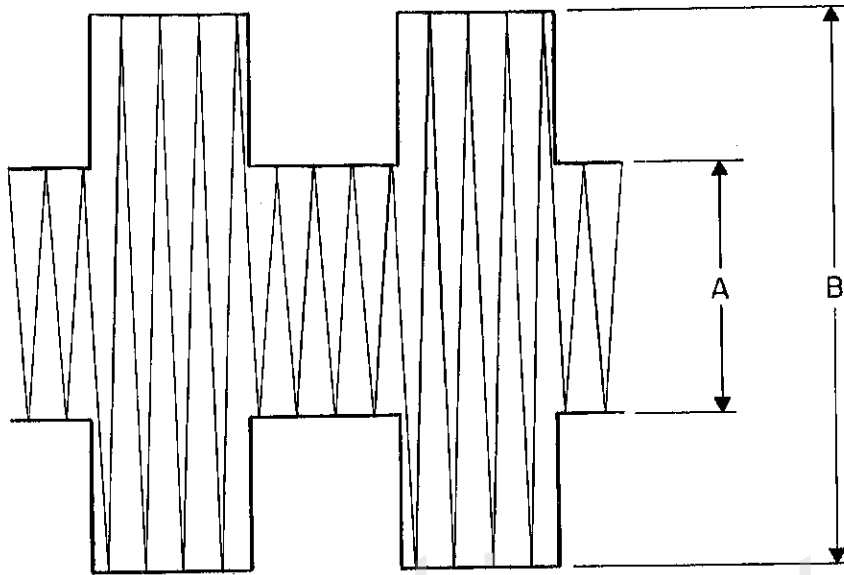
F. R-F RESOLVER ALIGNMENT

(1) Alignment Procedures

DETAIL STEPS/WORK ITEMS

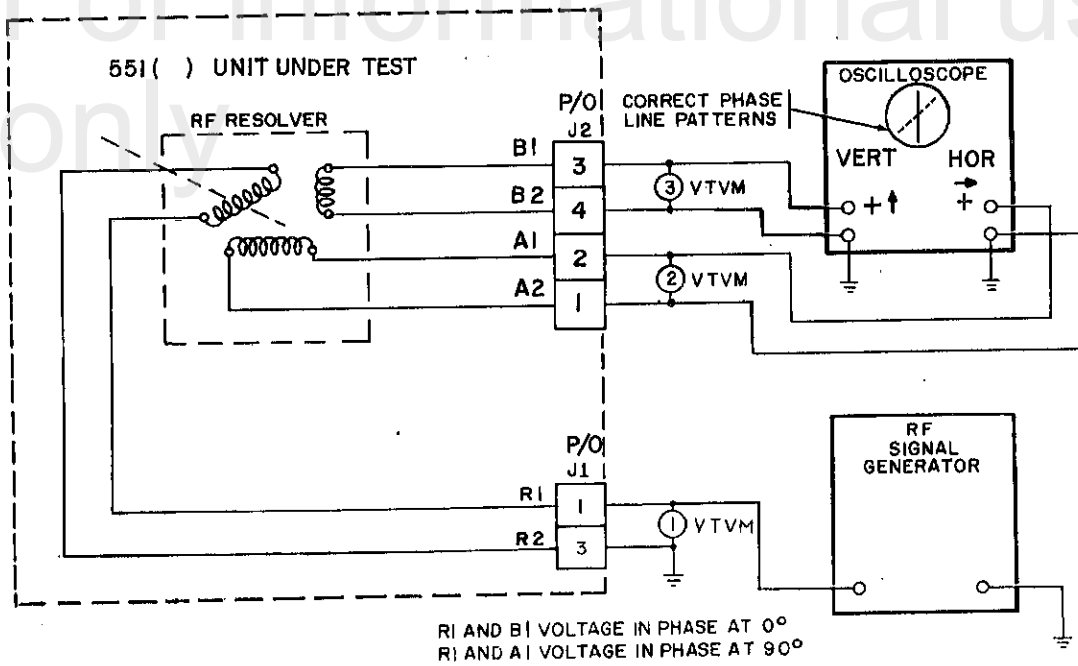
- (a) Remove the dust cover from servo amplifier indicator unit. See Figure 5-3.
- (b) Connect the equipment as shown in Figure 3-7.
- (c) Adjust the signal generator to 200 kHz with an output of 0.5 volts as indicated on VTVM no. 1.
- (d) Rotate the gear train until the pointer reads zero. Use a gear close to the servo motor to rotate the gear train.
- (e) Loosen the two screws that hold resolver to mounting plate.
- (f) Rotate resolver until the oscilloscope trace is vertical and the voltage indicated on VTVM No.2 is at a minimum. See that the resolver output gear does not rotate.
- (g) Disconnect the wire from plug J2 pin 2. Connect a wire from plug J2 pin 1 to the + horizontal input of the oscilloscope.
- (h) Oscilloscope pattern must show in-phase condition for correct zero position of resolver rotor. The in-phase condition exists when the oscilloscope trace is inclined approximately 45 degrees to the right as shown in Figure 3-7. If the trace is not inclined approximately 45 degrees, rotate the resolver 180 degrees.
- (i) Re-connect the wire from plug J2 pin 2 to the scope and disconnect the wire from pin 1 to the scope.
- (j) Tighten screws and rotate gear train through 360 degrees. If the scope trace does not follow the direction and angle of the pointer, one pair of wires (A1-A2, B1-B2, or R1-R2) is reversed. Check the color coding of the resolver with the appropriate schematic in this manual.

SECTION III
 MAINTENANCE PRACTICES



$$\text{MODULATION \%} = \frac{B-A}{B+A} \times 100$$

Typical Modulation Percentages
 Figure 3-6



Resolver Alignment Set-Up
 Figure 3-7

SECTION III

MAINTENANCE PRACTICES

3-2. F. (1)

- (k) Check null points at zero and 180 degrees on vtvm No. 2.
- (l) Check null points at 90 and 270 degrees on vtvm No. 3.

G. SERVO AMPLIFIER - INDICATOR ALIGNMENT

(1) Amplifier Gain Test

- (a) Units with old type motor (refer to schematic diagram summary of changes page for S/N effectivity of motor change).
 - 1 Connect the test equipment to the servo amplifier-indicator as illustrated in figure 3-8.
 - 2 Adjust the phase control potentiometer (of the test "rig") for 0.5 millivolts (above residual voltage) indicated on the vtvm connected to pin 7. Clockwise rotation of the phase control potentiometer should result in clockwise rotation of the indicator needle and vice-versa.
 - 3 Adjust the servo sensitivity (R25) control (where applicable) fully counterclockwise. In this position R25 establishes maximum gain of Q5 and Q6.
 - 4 Adjust the amplifier frequency control (R15) for maximum indication on the dc vtvm connected across servo motor. With R15 properly adjusted, the feedback network allows 47 Hz to predominate in the motor drive circuits.

NOTE

The residual voltage is the voltage present across motor when the phase control potentiometer is centered as accurately as possible. This voltage is very small. Somewhere in the order of 0.5 to 2.5 millivolts depending upon the particular unit under test. If the indicator pointer hunts excessively refer to Table 4-1 Symptom H.

- 5 Adjust the phase control potentiometer for 2 mv (above residual voltage), and observe vtvm across motor. Vtvm must indicate 2.5 Vdc minimum.
- 6 Adjust the phase control potentiometer for 10 mV (above residual voltage), and observe vtvm across motor. Vtvm must indicate 5 Vdc minimum.

SECTION III
MAINTENANCE PRACTICES

3-2. G. (1)(a)6

NOTE

R25 may be readjusted, after installation of unit in aircraft, to increase or decrease pointer sensitivity as desired by customer.

(b) Units with new type motor (refer to schematic diagram summary of changes page for S/N effectivity of motor change.

- 1 Connect the test equipment to the servo amplifier-indicator as illustrated in figure 3-8.
- 2 Rotate the phase control potentiometer (of the test "rig") CCW until the dc voltage on the vtvm connected across the motor is 2.5-to 3.0-volts.
- 3 Adjust frequency control (R15) for a dc voltage peak across the motor while maintaining the peak at 2.5- to 3.0-volts by use of the phase control potentiometer.
- 4 Rotate the phase control potentiometer until the dc voltage across the motor is zero volts. Note the residual ac voltage input on the ac vtvm connected to pin 7.
- 5 Adjust servo sensitivity control (R25) until the pointer is just rotating CW as the phase control potentiometer is adjusted for 0.4 mV above the residual ac voltage input.
- 6 Adjust the phase control potentiometer for 2 mV (above the residual ac voltage input) and observe vtvm across motor. Vtvm must indicate 2.5 Vdc minimum.
- 7 Adjust the phase control potentiometer for 10 mV (above the residual ac voltage input) and observe the vtvm across motor. Vtvm must indicate 3 Vdc minimum.

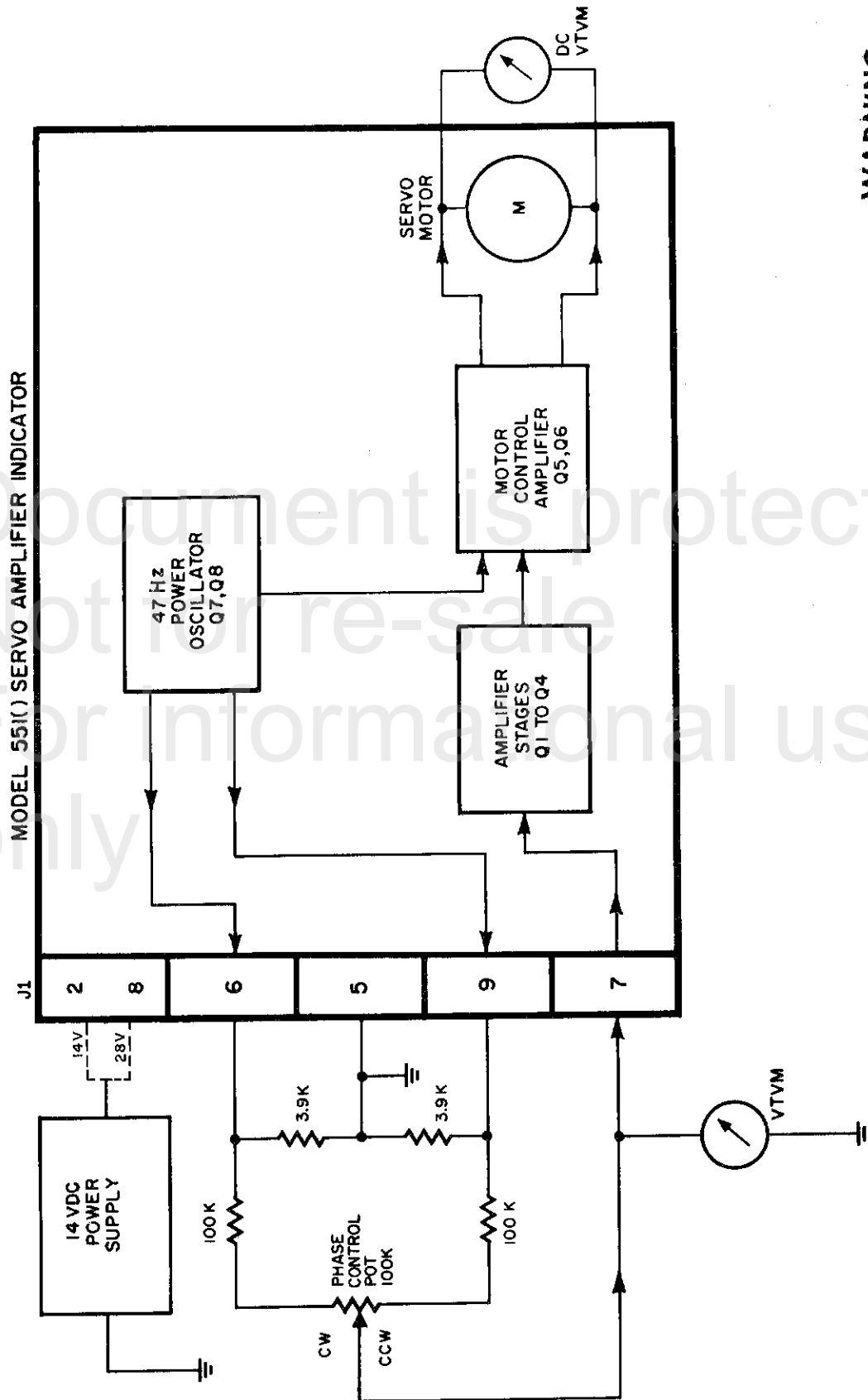
NOTE

R25 may be readjusted, after installation of unit in aircraft, to increase or decrease pointer sensitivity as desired by customer.

(2) Indicator Rotation Speed

- (a) Adjust phase control potentiometer for 10 mV (above residual voltage) and observe the time it takes for the indicator pointer to rotate 360 degrees. Pointer should take not more than 9 seconds to rotate 360 degrees.

SECTION III
MAINTENANCE PRACTICES



WARNING

This manual which you have requested is furnished for general information purposes only. Service bulletins which supplement this manual are only furnished to Bendix authorized FAA approved repair stations. DO NOT USE THIS MANUAL FOR EFFECTUATING REPAIRS OF THE EQUIPMENT.

Servo Amplifier-Indicator Bench Test Set-Up
Figure 3-8

Document is protected
Not for re-sale
For informational use
only

SECTION III

MAINTENANCE PRACTICES

3-2. G.

(3) Switching Voltage Test

- (a) Measure the oscillator switching voltage from pin 6 to ground and pin 9 to ground, with an average reading instrument, calibrated rms. Voltage should indicate a minimum of 7.5v rms at each point.

H. RECEIVER TESTS

(1) Receiver Sensitivity (MCW)

- (a) Connect the equipment as illustrated in Figure 3-2. Allow 15 minutes for test equipment warm-up.
- (b) Set output meter for 500 ohm load.
- (c) Set the receiver function switch to REC position.

NOTE

R-f and i-f alignment procedures must have been performed before continuing with this procedure.

- (d) Adjust the receiver to 200 kHz and adjust the signal generator No. 2 for a peak on the tuning meter. Modulate the generator 30% at 400 Hz.
- (e) Adjust the signal generator output to 145 μ v.
- (f) Adjust the VOL control for 20 milliwatts audio output as indicated on the output power meter.
- (g) Remove the 400 Hz modulation signal and the audio output should drop a minimum of 6 db.
- (h) Repeat steps (c) through (g) at the following frequencies and corresponding generator levels.

TABLE 3-2

Frequency kHz		Signal Generator Level
Band 1.	250	145 μ volts
	350	100 μ volts
Band 2.	500	100 μ volts
	700	55 μ volts
Band 3.	1000	85 μ volts
	1400	55 μ volts

SECTION III
MAINTENANCE PRACTICES

3-2.H.

- (2) Receiver Sensitivity (CW)
- (a) Set receiver and signal generator (no modulation) to 300 kHz.
 - (b) Set Volume control to full CW position.
 - (c) Adjust signal generator output to 80 μ volts.
 - (d) Set function switch to BFO and note that audio output increases a minimum of 6 db.
- (3) Receiver Selectivity Test
- (a) Connect the equipment as illustrated in figure 3-2. . .
 - (b) Set output meter for 500 ohm load.
 - (c) Set receiver function switch to REC position.
 - (d) Adjust signal generator No. 2 and receiver to 300 kHz (no modulation).
 - (e) Adjust signal generator output for a 1/4 scale deflection on the tuning meter. Note this reading and the signal generator voltage. They will be used as references.
 - (f) Increase output of generator 6 db and detune generator on the low side of the center frequency until the tuning meter indicates the same reading as was found in step(e). Record the frequency (use frequency counter).
 - (g) Detune generator on the high side of the center frequency until the tuning meter indicates the same reading as was found in step (e). Record the frequency.
 - (h) Subtract the frequency obtained in step (f) from the frequency in step (g). The difference between the two frequencies is the 6 db bandwidth and should be a maximum of 4 kHz.
 - (i) Increase the output of the signal generator 60 db from that level obtained in step (e) and detune the signal generator on the low side of the center frequency until the tuning meter indicates the same reading as was found in step (e). Record the frequency.
 - (j) Detune the generator on the high side of the center frequency until the tuning meter indicates the same reading as was found in step (e).
 - (k) Subtract the frequency obtained in step (i) from the frequency obtained in step (j). The difference between the two frequencies is the 60 db bandwidth and should be a maximum of 12 kHz.
 - (l) Perform steps (d) through (k) at 600 kHz and 1200 kHz. The 6 db bandwidth should not exceed 4 kHz. The 60 db bandwidth should not exceed 12 kHz.

SECTION III
MAINTENANCE PRACTICES

3-2.H.

(4) ADF Sensitivity

- (a) Adjust the receiver and signal generator to 250 kHz.
- (b) Modulate the signal generator 30% at 400 Hz, and adjust the output to 600 μ volts.
- (c) Set the Function switch to ADF (turn speaker switch off) and adjust the VOL control for 20 MW on the output meter.
- (d) Remove modulation and record db drop.
- (e) Using Table 3-3 make ADF sensitivity measurements at the indicated frequencies and signal levels.

TABLE 3-3

FREQUENCY kHz		SIGNAL GENERATOR LEVEL	db DROP 6 db MINIMUM
Band 1.	250	600 μ volts	6 db minimum
	350	450 μ volts	6 db minimum
Band 2.	500	550 μ volts	6 db minimum
	700	275 μ volts	6 db minimum
Band 3.	1000	350 μ volts	6 db minimum
	1400	200 μ volts	6 db minimum

(5) Bearing Error and Speed of Rotation

- (a) Set receiver and signal generator to 200 kHz.
- (b) Adjust signal generator output to 350 μ volts modulated 30% at 400 Hz.
- (c) Rotate the indicator needle 175° away from indicated bearing by using the Test Button.
- (d) Release the Test Button and note the time required for the needle to return to within 2° of indicated bearing. Time should not exceed 7 seconds.
- (e) Vary the signal level from 350 μ volts to 0.1 volts and note that the bearing remains within $\pm 3.0^\circ$ of indicated bearing.
- (f) Repeat steps (b), through (e) at frequencies of 400 kHz (Band 2) and 800 kHz (Band 3).

SECTION III
MAINTENANCE PRACTICES

3-2.H.

(6) Frequency Accuracy

- (a) Connect the R-F signal generator through the "dummy" test antenna to terminal 1 of connector J1. Refer to figure 3-2 using r-f generator No. 2.
- (b) Place the receiver function switch to the REC position.
- (c) Dial up 1200 kHz and place the band switch in the 800-1600 position.
- (d) Adjust the signal generator for a peak on the tuning meter and set the generator output for a 1/2 scale deflection on the meter.
- (e) Connect the frequency counter to signal generator and read the frequency. The frequency should be 1200 ± 0.5 kHz.

(7) Synthesizer Operational Check

- (a) Connect the frequency counter to TP4 and set its controls to read X1 kHz.
- (b) Using the following chart (Table 3-4) dial up the indicated frequencies and read on the counter the frequency dialed up plus 140 kHz, i. i., 200 kHz dialed, read (200 kHz) + 140 kHz which is equal to 340 kHz.
- (c) As each frequency is dialed in note that the monitor lamp goes out indicating proper tuning. Remember to change the band switch accordingly.

SECTION III
MAINTENANCE PRACTICES

3-2.H. (7)

TABLE 3-4

	Frequency Dialed	Read On Counter (N+140 kHz ± 0.2 kHz)
BAND 1.	195	335
	200	340
	260	400
	300	440
	360	500
	400	540
	405	545
BAND 2.		
	395	535
	400	540
	460	600
	500	640
	560	700
	600	740
	660	800
	700	840
	760	900
	800	940
805	945	
BAND 3.		
	795	935
	800	940
	860	1000
	900	1040
	960	1100
	1000	1140
	1060	1200
	1100	1240
	1160	1300
	1200	1340
	1260	1400
	1300	1440
1605	1745	

SECTION III
MAINTENANCE PRACTICES

3-2.

I. AUDIO AMPLIFIER TEST (102A and B)

(1) Audio Gain

DETAIL STEPS/WORK ITEMS

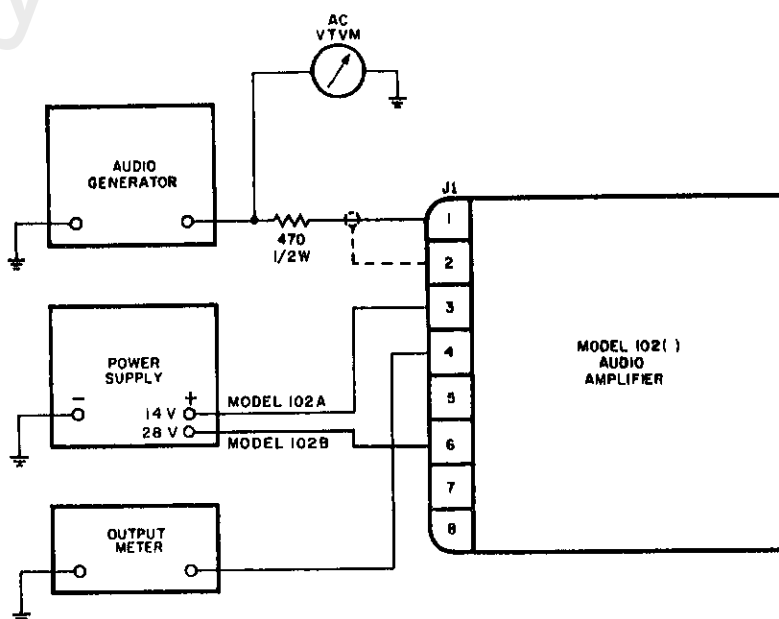
- (a) Connect the test equipment to the audio amplifier as illustrated in Figure 3-9. Connect plus terminal of power supply to pin 3 of Model 102A or to pin 6 of Model 102B.
- (b) Turn on test equipment and allow 15 minutes warm-up time.
- (c) Position IMPEDANCE switch on the output meter to 3 ohms.
- (d) Adjust the audio generator to 1000 Hz and an audio amplifier output of 1 watt. The audio input shall not exceed 10 volts rms.

(2) Maximum Power Output

- (a) Adjust the audio generator to 1000 Hz and an audio amplifier output of 3.5 watts (102A) or 10 watts (102B). The voltage input indicated on the vtvm should be less than 17.5 volts rms.

(3) Frequency Response

- (a) Adjust the audio generator to 1000 Hz and an audio amplifier output of 1 watt.
- (b) Adjust the audio generator to 350 Hz, 750 Hz, 1500 Hz, 200 Hz and 2500 Hz (in that order). The output level indicated on the output meter should be no greater than +1 db or -4 db from the 1000 Hz reference for the five frequency positions tested.



Audio Amplifier Bench Test Set-Up
Figure 3-9

SECTION IV
TROUBLESHOOTING

4-1. GENERAL

The tabulated procedures detailed in this section are designed to isolate malfunctions in the ADF-T12D System to the level where operational tests, signal tracing, or voltage and resistance measurements can profitably be made.

4-2. TRANSISTOR AND INTEGRATED CIRCUITS (IC) TESTING METHODS

Many conventional methods of troubleshooting electronic equipment can be destructive when applied to transistorized equipment. Although transistors can withstand much greater physical abuse than vacuum tubes, they are particularly sensitive to heat and excessive voltage. Before attempting to service the ADF-T-12D System, maintenance personnel should become familiar with the information contained herein.

A. Signal Tracing

Stage-by-stage signal tracing is the most effective method for locating trouble in the system. This procedure is accomplished by connecting an output meter or oscilloscope across the output of a stage and injecting a known signal into the input of that stage. A comparison of the injected signal with the resultant output signal indicates the operating condition of that stage. Typical waveforms and RMS voltages existing at various stages of a representative receiver and servo amplifier-indicator are shown in Tables 4-3 and 4-4. During signal tracing or when making measurements, care must be exercised to prevent the test equipment from adversely influencing the circuits under test. Proper methods of coupling the test equipment during measurement procedures are illustrated in Figures 3-2, 3-8 and 3-9.

B. D-C Voltage Measurements

The voltages encountered in this equipment are less than 28 vdc. Meters with a sensitivity of 20,000 ohms per volt are satisfactory for these voltage measurements. Due to the inherent voltage variation characteristics of zener diode CR13 (ADF Receiver) and CR1 (Servo Amplifier Indicator), the typical voltages to be found on the A+ line of the receiver and indicator circuits would be in the area of 7.5 to 10 volts d-c.

The voltages across the leads of typical ohmmeters, are in many cases equal to the operating potentials of transistors. Therefore, connecting an ohmmeter across a transistorized circuit might cause the transistor to conduct, or become forward-biased from a previously reverse-biased state. This will result in erroneous indications of the ohmmeter. In some cases, the meter potentials may be sufficiently high to damage the transistor. Transistors should always be removed from the circuit before taking resistance measurements. In cases where the transistors are soldered into the circuit board and cannot be easily removed, resistance measurements should not be performed.

SECTION IV
TROUBLESHOOTING

4-2.

C. Transistor And IC Checking

Transistor failure is seldom encountered under normal operating conditions. The few cases of failure are due to excessive voltage or heat. Once a transistor has been damaged it will generally be completely inoperative. In some cases, damage will be evidenced by increased noise. The best way to check a transistor is to replace it with one known to be good. A transistor checker may also be used where marginal performance is suspected.

D. Varicap Diodes

CR19, CR14, CR15, CR16, and CR17, are a matched set. The parameters of the Varicap Diodes are carefully matched at the factory to provide optimum receiver performance.

If a defective module is replaced, the Varicap Diode shall be removed and rewired into the replacement module. In the event one or more Varicap Diodes are found defective, a new matched set will be required.

CAUTION

TO MINIMIZE VARICAP DIODE BREAKAGE, GRASP
LEAD WITH NEEDLE NOSE PLIERS BETWEEN THE
SECTION TO BE BENT AND THE VARICAP DIODE BODY.

The replacement Varicap Diode set will contain two Varicap Diodes with white dots, one Varicap Diode with a yellow dot and two Varicap Diodes with no color dots. Install the Varicap Diodes as follows: Yellow dot in VCO module (CR17), white dot in Mixer module (CR15 and CR16) and remaining Varicap Diodes (no color dot) in Loop module (CR19) and RF module (CR14).

After replacing a complete set of Varicap Diodes it will be necessary to establish new Band End Tuning Voltage limits.

- (1) Refer to paragraph 3-2. E. (2) and perform the Voltage Controlled Oscillator Alignment using 1.25 ± 0.1 vdc for the low frequency end and 5.5- to 6.7-vdc for the high frequency end of the three bands.
- (2) Perform the R-F and Loop Stage Alignment, paragraph 3-2. E. (3) and 3-2. E. (4).
- (3) If any of the following symptoms should occur during alignment increase the low frequency end tuning voltage to $1-35 \pm 0.1$ vdc.
 - (a) The oscillator slug range is insufficient to get the low frequency end tuning voltage down to 1.25 volts.
 - (b) The oscillator trimmer range is insufficient to get the high frequency end tuning voltage up to between 5.5- and 6.7-volts.

SECTION IV
TROUBLESHOOTING

4-2.D.

- (c) If any tuning slugs protrude beyond the R-F module shield.
- (d) If any trimmer capacitors are at the maximum capacitance position.
- (e) There is an excessive mistracking in the band centers. This will show up as poor sensitivity or low loop drive voltage at the band centers only.
- (f) In the event that increasing the low frequency end tuning voltage to 1.35 volts is insufficient, continue increasing in steps but do not go beyond 1.7 volts.
- (g) Upon completion of the complete alignment remark the Band End Tuning Voltage decal with the new voltages that were established.

E. Troubleshooting Tables

The troubleshooting table is designed to assist the technician in recognizing some of the more probable symptoms (and what to do about them) that might be encountered during operation of the system. No special equipment is needed to perform the procedural steps outlined in the table.

Document is unclassified
Not for re-sale
For informational use
only

Document is protected
Not for re-sale
For informational use
only

SECTION IV
TROUBLESHOOTING

4-2.

TABLE 4-1

SYMPTOM	PROCEDURE	RESULT	PROBABLE CAUSE OR CORRECTIVE ACTION
A. No audio in headset: Function switch in Rec. position.	1. Set function switch to ADF	A. Sound in headset Mon. light out. Pointer moves. B. Symptom unchanged.	1. Sense Antenna grounded or disconnected. 2. No d-c reaching terminal 15 of receiver. Check primary d-c fuse, external cable and CR13.
B. No audio. Function switch in Rec.	1. Set function switch to ADF.	A. Indicator rotates or nulls. B. Pointer stationary.	1. Audio amplifier Q11, Q12, Q13 defective, or Audio gain control R51 or R52 open. 2. Audio amplifier Q10 defective.
C. Hash on one or two bands. Other operative.	1. Check bandswitch for continuity and positive operation.	A. Bandswitch OK.	1. Defective inter-stage transformers.
D. System OK in Rec. but inoperative in ADF position. Mon. light out.	1. Tune in station in Rec. Switch to ADF and press test switch.	A. Pointer rotate. B. Pointer stationary.	1. Defective loop Q1 or balanced modulator CR1 thru CR4. 2. Defective servo-amp indicator, or Defective power osc.
E. Equipment takes definite bearing 180 degrees reversed.	1. Check loop antenna connections to r-f resolver.	A. Connections OK. B. Connections reversed.	1. Connections between resolver and receiver reversed. 2. Change connections.

SECTION IV
TROUBLESHOOTING

4-2

TABLE 4-1 (Continued)

SYMPTOM	PROCEDURE	RESULT	PROBABLE CAUSE OR CORRECTIVE ACTION
F. Equipment takes definite bearings with a consistent error.			1. Loop antenna centerline not aligned with centerline of aircraft.
G. Equipment takes correct bearings near 0 and 180 degrees, but readings become increasingly inaccurate as 90 and 270 degrees are approached.			1. Quadrantal error. Relocate fixed loop. See INSTALLATION MANUAL.
H. Indicator pointer hunts excessively on all bearings.	1. Re-adjust sensitivity control R25 (where applicable) in servo amplifier-indicator until "hunting" of indicator pointer is reduced. See figure 5-7 for location of control (R25).	A. Indicator pointer still hunts excessively.	1. Poor installation. See Table 103. 2. Check output transistors Q5 and Q6 and diode CR3 and CR4 in servo amplifier-indicator. 3. Defective filter capacitor C9, C10, C11, C12 or C14.
I. Excessive audio distortion on strong signals.	1. Readjust AGC.	A. Distortion unchanged	1. Defective AGC circuit. Check AGC Amp Q9. 2. Check diodes CR5, CR7, CR9 and CR10.

SECTION IV
TROUBLESHOOTING

4-2.

TABLE 4-1 (Continued)

SYMPTOM	PROCEDURE	RESULT	PROBABLE CAUSE OR CORRECTIVE ACTION
J. Servo amp-indicator			<ol style="list-style-type: none"> 1. Check surge protector CR1 in servo amplifier indicator for open circuit. 2. Check motor for "shorts".

F. Troubleshooting Marginal Performance

In most cases the troubleshooting chart, Table 4-1 will localize a failure to the point where simple voltage and resistance measurements will enable the technician to locate the specific malfunctioning components. In some cases, however, failure of the equipment will be evidenced by marginal performance. For instance, it will take bearings, but slowly. The indicator pointer may hunt excessively, or the sensitivity or selectivity of the equipment may be inadequate. In cases such as these proceed as follows:

(1) Check the Installation

A poor installation is frequently the cause of marginal performance. Use Table 4-2 to check the installation.

TABLE 4-2

INSTALLATION CHECK

WHAT TO CHECK	HOW TO CHECK	REMARKS
A. Sense Antenna	<ol style="list-style-type: none"> 1. Gently vibrate sense antenna while observing connections to fuselage. 2. Check to see that stand-off insulators are clean and in good condition. 3. Examine sense antenna connections to receiver. 	<p>Mounting must not be checked for corrosion and broken sense antenna wire.</p> <p>There must be no looseness in fasteners; the ground connections to cabling must be secure and not corroded.</p>

SECTION IV
TROUBLESHOOTING

TABLE 4-2 (Continued)

WHAT TO CHECK	HOW TO CHECK	REMARKS
B. Fixed Loop	<ol style="list-style-type: none"> 1. Examine antenna housing and check that loop is fastened tight against aircraft skin. 2. Examine loop connections to receiver. 3. Check that loop lead-in is of the recommended type and length. 	<p>Check for missing bolts and dented or torn housing. Check that housing is free of paint.</p> <p>Check for loop connector pin corrosion.</p>
C. ADF Receiver, and servo amp-indicator.	<ol style="list-style-type: none"> 1. Be sure all cable connector locking rings are tight. 2. Check that all components are properly bonded to the airframe. 	Loose connections can cause intermitten operation.
D. Frequency Selectors	<ol style="list-style-type: none"> 1. Dial various frequencies. 	Check monitor light for proper tuning.
E. Band switch	<ol style="list-style-type: none"> 1. Change bands. 	Listen for positive switching action.
F. VOL control	<ol style="list-style-type: none"> 1. Rotate both directions. 	Binding or too loose operation can result in excessive noise.
G. Function Switch	<ol style="list-style-type: none"> 1. Set to REC. 	Panel lamp should light, and equipment operate as a communications receiver.

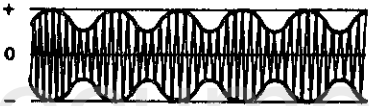

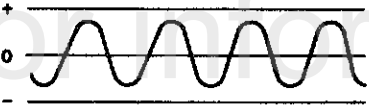

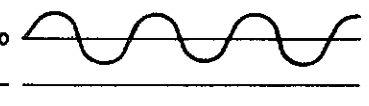
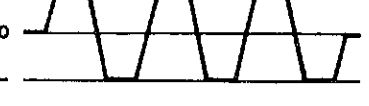
(2) Waveforms and RMS Voltage Tables 4-3 and 4-4

Marginal trouble due to misalignment of the equipment or sub-standard performance of the components can be localized to a single stage by the signal tracing method. Tables 4-3 and 4-4 show the signal voltage level and waveshape at selected stages of the equipment.

SECTION IV
TROUBLESHOOTING

4-2.F.(2)

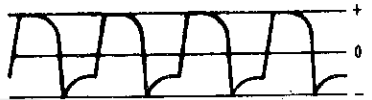

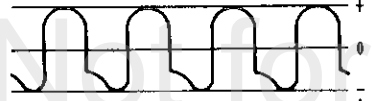




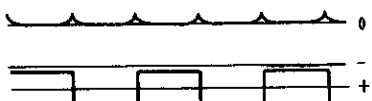
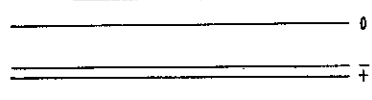
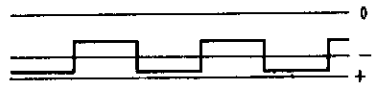
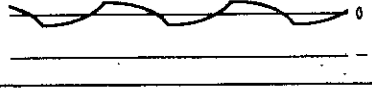
TABLE 4-3

ADF RECEIVER CONDITIONS:			
<u>Frequency:</u> 200 Hz		Input: 100 μ v, modulated	
<u>Vol Control:</u> Adjust for 50 mv into 500 ohms		30% at 400 Hz	
<u>Function:</u> ADF		All voltages measured to ground, $\pm 10\%$	
WAVEFORMS	FREQUENCY	TEST POINT	RMS VOLTAGE
	140.0 kHz	TP1	2.0 v
	400 Hz	Pin 4 (T6)	170 mv
	400 Hz	Coll. (Q10)	400 mv
	400 Hz	C. T. (R51)	30 mv
	400 Hz	Coll. (Q12)	3.3 v
	47 Hz	Pin 8 (j1)	8.5 v

SECTION IV
TROUBLESHOOTING

4-2.F.(2)

TABLE 4-4

SERVO AMPLIFIER-INDICATOR CONDITIONS FOR UNITS WITH OLD TYPE MOTOR (REFER TO SCHEMATIC SUMMARY OF CHANGES PAGE FOR EFFECTIVITY)			
<u>Frequency:</u> 200 kHz Loop rotated 90° from null (Motor 8) gear must be disengaged from gear train prior to rotating loop.) <u>Input:</u> 100 μv, unmodulated		<u>Function:</u> ADF All voltages measured to ground ±10%	
WAVEFORM	FREQUENCY	TEST POINT	RMS VOLTAGE
	47 Hz	Pin 7 (J1)	.15v
	47 Hz	Coll. (Q1)	1.3v
	47 Hz	Base (Q2)	.15v
	47 Hz	Coll. (Q3)	.6v
	47 Hz	Coll. (Q4)	1.5v
	47 Hz	Base (Q5)*	.9v
	47 Hz	Base (Q6)*	1.8v
	47 Hz	Emitt. (Q5)	.18v
	47 Hz	Coll. (Q5)*	2.6v
	47 Hz	Coll. (Q6)*	-2.6v
	47 Hz	Base (Q7)	.28v

*or vice versa, depending upon phase of ADF signal at these test points.

SECTION IV
TROUBLESHOOTING

TABLE 4-4A


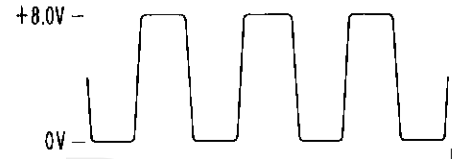
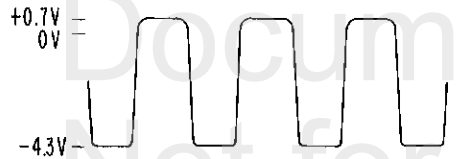


SERVO AMPLIFIER-INDICATOR CONDITIONS FOR UNITS WITH NEW TYPE MOTOR (REFER TO SCHEMATIC SUMMARY OF CHANGES PAGE FOR EFFECTIVITY)			
<u>Frequency:</u> 200 kHz. <u>Input:</u> 1000 μ V, unmodulated. Remove motor (8) from indicator (do not disconnect wiring). Use a clip lead from chassis ground to motor frame. With loop at 0° (null), manually rotate indicator pointer to 90° (off null).		<u>Function:</u> ADF All voltages measured to ground $\pm 20\%$. Scope triggered from collector of Q7.	
WAVEFORMS	FREQUENCY	TEST POINT	P-P VOLTAGE
	47 Hz	Pin 7 (J1)	0.2
	47 Hz	Coll. (Q1)	2.0
	47 Hz	Coll. (Q2)	1.0
	47 Hz	Coll. (Q3)	1.2
	47 Hz	Coll. (Q4)	4.0
	47 Hz	Base (Q5)*	6.0

*Q5 and Q6 waveforms may be reversed depending on phase of ADF signal [pin 7 (J1)].

M2042024

SECTION IV
TROUBLESHOOTING

TABLE 4-4A (Continued)

WAVEFORMS	FREQUENCY	TEST POINT	P-P VOLTAGE
	47 Hz	Base (Q6)*	4.0
	47 Hz	Coll. (Q5)*	8.0
	47 Hz	Coll. (Q6)*	5.0
	47 Hz	Coll. (Q7)	18.0
	47 Hz	Base (Q10)	1.35

*Q5 and Q6 waveforms may be reversed depending on phase of ADF signal [pin 7 (J1)] .

M2042024

SECTION IV

TROUBLESHOOTING

4-2. F. (2)

RECEIVER, SYNTHESIZER TROUBLESHOOTING

TABLE 4-5

SYMPTOM	PROCEDURE	RESULT	PROBABLE CAUSE OR CORRECTIVE ACTION
A. Synthesizer fails to lock in upper or lower portion of each band. Mon. lamp is on, VCO oscillates at all points.	1. Dial up 600 kHz. 2. Set band switch to Band 1. 3. Measure voltage at TP106, should be equal to or greater than 4.5 vdc. Use digital vm.	A. Voltage incorrect. B. Voltage correct.	1. Phase detect U115 at fault. 2. Amplifier Q105 at fault.
	4. Set band switch to Band 3. 5. Measure voltage at TP106, should be equal to or less than 1.0 vdc. Use digital vm.	A. Voltage incorrect. B. Voltage correct.	1. Phase detector U115 at fault. 2. Amplifier Q105 at fault.
B. Synthesizer fails to lock at any frequency, Mon. lamp on or off, TP-8 is equal to or less than 1.0 V DC at all times.	1. Check TP103 with oscilloscope. 2. 1 kHz present equal to or no greater than 2.5 volts p-p.	A. Yes, go to troubleshooting symptom A B. No, go to next procedure	
	3. Check TP102 with oscilloscope 4. 256 kHz, equal to or greater than 2.5 volts p-p. 5. Check TP101 with oscilloscope 6. Is 256 kHz, 1 vp-p present?	A. Yes B. No, check TP101 A. No. B. Yes.	1. Divide by 16 counters at fault. 1. Oscillator at fault. 2. Buffer stage at fault.

SECTION IV
TROUBLESHOOTING

4-2.F.(2)

TABLE 4-5 (Continued)

SYMPTOM	PROCEDURE	RESULT	PROBABLE CAUSE OR CORRECTIVE ACTION
<p>C. Synthesizer fails to lock at any point. Mon. lamp may be on or off. Voltage as measured at TP-108 with oscilloscope is equal to but no greater than 8 volts. VCO is oscillating.</p>	<ol style="list-style-type: none"> 1. Check TP104 for any signal no greater than 2.5 volts p-p. 2. Check TP105, is reset pulse present? 3. Set Freq. Sel. to 860 kHz. 4. Measure freq. TP104. 5. Measure period of pulses at TP105 $P_r = \frac{1000}{\text{FREQ.}} = 1 \text{ ms}$ 	<p>A. No.</p> <p>B. Yes. Go to procedure 2</p> <p>A. No.</p> <ol style="list-style-type: none"> a. Always logic (HI) b. For frequencies less than 860kHz <p>2. U103, U104, or U105 always (low)</p> <p>B. Yes, go to procedure 3.</p> <p>A. Yes.</p> <p>B. No.</p>	<ol style="list-style-type: none"> 1. Buffer stage at fault. <ol style="list-style-type: none"> 1. Check U106B, U107C and U107A for fault. 2. U103, U104, or U105 at fault. <ol style="list-style-type: none"> 1. Phase detector at fault. 2. Check programming to U103, U104 & U105.
<p>D. Mon. Lamp OFF. Synthesizer locks to wrong freq. for 10 kHz selector positions 6, 7, 8, 9. Positions 0, 1, 2, 3, 4, and 5 are OK.</p>	<ol style="list-style-type: none"> 1. Check U112D 	<p>A. Defective.</p> <p>B. OK. Check wiring to freq. selector switches.</p>	<ol style="list-style-type: none"> 1. Replace 2. Broken wire.
<p>E. Mon. lamp OFF. Synthesizer locks to wrong freq. for 10 kHz selector positions 0, 1, 2, 3, 4, and 5, 6, 7, 8, 9 are OK. Same as Symptom D</p>			

SECTION IV
TROUBLESHOOTING

4-2.F. (2)

TABLE 4-5 (Continued)

SYMPTOM	PROCEDURE	RESULT	PROBABLE CAUSE OR CORRECTIVE ACTION
F. In symptoms G through J it will be noted that the freq. of the VCO will not go above 1 MHz.			
G. Synthesizer locks to wrong freq. for freq's greater than 1 MHz. Mon. lamp is OFF, but does not lock for freq's less than 1 MHz.	1. Check operating conditions of U107B. Also see symptom E.	A. Defective B. OK, check associated circuitry.	1. Replace 2. Repair or replace.
H. Synthesizer locks to wrong freq. for freq's from 860 kHz to 899 kHz.	1. Check operating conditions of U111B.	A. Defective B. OK. Check associated circuitry.	1. Replace 2. Repair or replace.
I. Synthesizer locks to wrong freq. for freq's from 900 kHz to 999 kHz.	1. Check operating conditions of U111C.	A. Defective B. Ok. Check associated circuitry.	1. Replace 2. Repair or replace.
J. Synthesizer will not exceed a VCO freq. of 1 MHz.	1. Check operating conditions of U111D, U106B.	A. Defective B. OK. Check associated circuitry.	1. Replace 2. Repair or replace.
K. Synthesizer will not lock for freq's below 860 kHz. Mon. Lamp is OFF.	1. Check operating conditions of U106B, U107B and U111D.	A. Defective B. OK. Check associated circuitry.	1. Replace 2. Repair or replace.

SECTION IV
TROUBLESHOOTING

4-2.F.(2)

TABLE 4-5 (Continued)

SYMPTOM	PROCEDURE	RESULT	PROBABLE CAUSE OR CORRECTIVE ACTION
L. Mon. lamp does not come on to indicate wrong band.	<ol style="list-style-type: none"> 1. Ground collector of Q111. 2. Check for pulses at U106A pin 6. 3. Check for approx. 1.5 volts at base of Q111. 	<p>A. Lamp comes on. B. No.</p> <p>A. No.</p> <p>A. Yes. B. No.</p>	<p>2. Replace lamp.</p> <p>1. Replace U106A.</p> <p>1. Q111 or Q112 at fault. 2. R134, R135, CR112 or C116 at fault.</p>
M. Mon. lamp on at all times.	<ol style="list-style-type: none"> 1. Check for less than 1 V at base of Q111. 2. Check for less than 0.3 volts at U106A pin 6. 	<p>A. Yes</p> <p>A. Yes B. No.</p>	<p>1. Q111 or Q112 at fault.</p> <p>1. R134, R135, or CR112 at fault. 2. Replace U106</p>

G. Synthesizer and Frequency Selector Operational Check

After working on the synthesizer or replacing parts in the vicinity of the following Procedure Along with paragraph 3-2.H.(7), will provide a means of checking out the operation of the synthesizer and frequency selectors.

- (1) Connect the frequency counter to TP-4 on the VCO board.
- (2) Using Table 4-5, dial up the indicated frequencies and read on the counter a frequency that is equal to the dialed frequency (N) plus 140 kHz.
- (3) As each frequency is dialed in, note that the monitor lamp goes out indicating proper tuning.

SECTION IV
TROUBLESHOOTING

TABLE 4-6 (Continued)

FREQUENCY DIALED (N)	READ ON COUNTER (N + 140 kHz) ± 0.2 kHz
200	340
201	341
202	342
203	343
204	344
205	345
206	346
<u>Band 1.</u> 207	347
208	348
209	349
210	350
220	360
230	370
240	380
250	390
260	400
270	410
280	420
290	430

SECTION IV
TROUBLESHOOTING

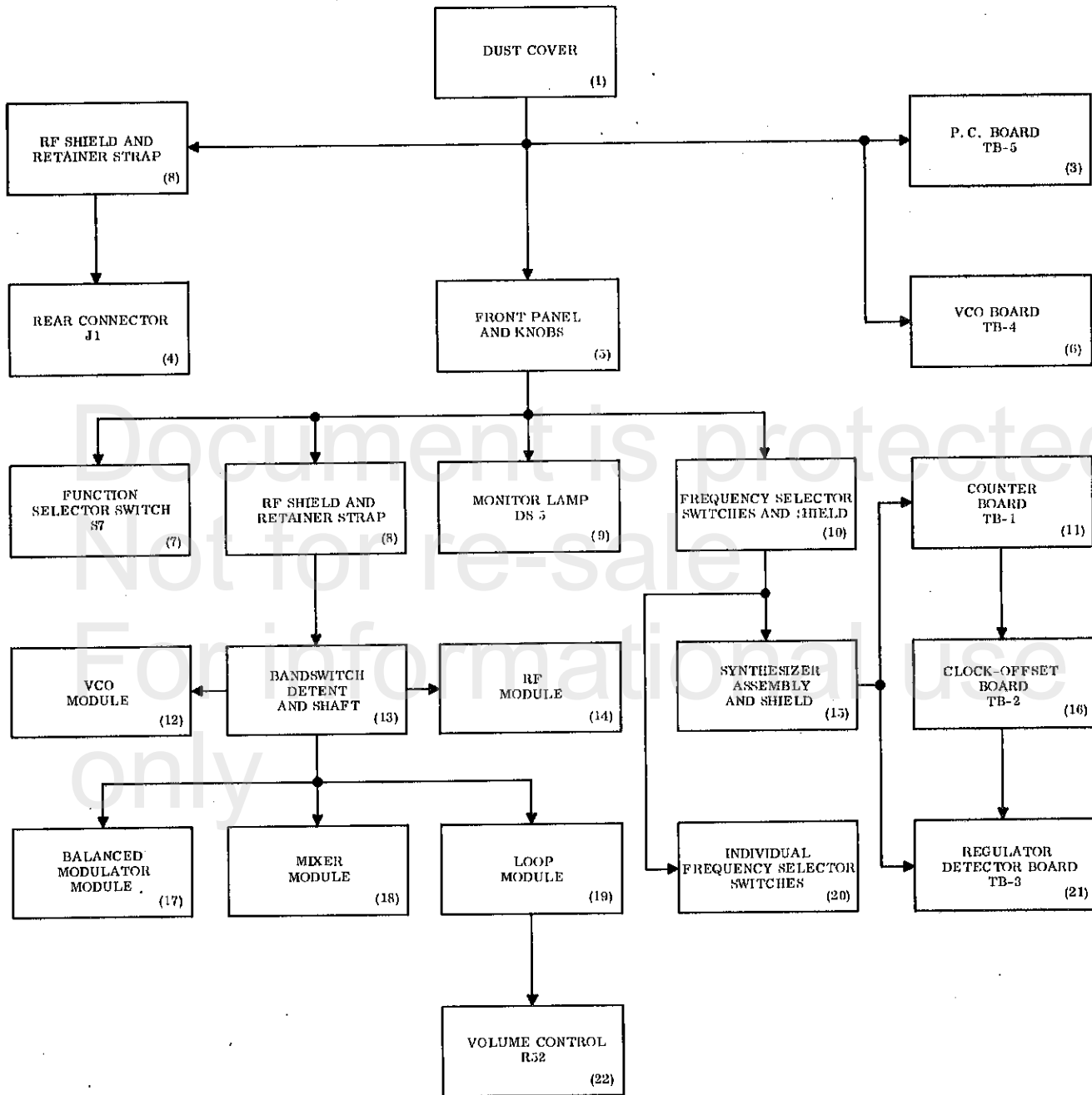


Figure 4-1
201F ADF Receiver Disassembly and Assembly Guide

SECTION IV
TROUBLESHOOTING

4-3. LUBRICATION

A. SERVO AMPLIFIER-INDICATOR

- (1) Lubrication of the servo amplifier-indicator gear train assembly is required at least every 1000 hours. Lubrication of the r-f resolver may be required whenever the resolver is overhauled.

DETAIL STEPS/WORK ITEMS

- (a) Remove the dust cover from the unit.
- (b) Apply one drop of Pioneer No. 11 oil to each felt washer of the gear train assembly while slowly rotating the gears. Avoid excess oil on gears.
- (c) Remove the r-f resolver (if necessary) for lubrication.
- (d) Apply a light film of grease to r-f resolver shaft.
- (e) Spin the resolver shaft to distribute grease evenly. Remove excess grease.
- (f) Re-assemble and test the resolver.

4-4. DISASSEMBLY PROCEDURE: RECEIVER

A. GENERAL

- (1) Disassemble only to the extent necessary for performing inspection, cleaning, alignment, or troubleshooting and repair.
- (2) These disassembly procedures apply only to the Model 201F ADF Receiver.
- (3) Refer to Figure 4-1, Disassembly/Assembly Guide, to determine what other subassemblies/components to remove first in order to reach a particular subassembly. For example: to gain access to the Clock-Offset Board, the dust cover, front panel, and knobs, Frequency Selector Switches and Shield, and the synthesizer shield assembly must be removed in sequence. Next, the synthesizer is disassembled by removing the Counter and/or the Regulator-Detector.

CAUTION: IMPROPER DISASSEMBLY MAY DAMAGE EQUIPMENT AND/OR IMPAIR REASSEMBLY.

B. PROCEDURE (See Figure 4-1 and 5-1)

- (1) Remove the dust cover (1):
- (a) Rotate retaining cam using a small phillips screwdriver inserted in the access hole in the upper left corner of the frequency selector switches assembly (10).

SECTION IV
TROUBLESHOOTING

4-4. B. (1)

- (b) Withdraw the receiver assembly from the dust cover using a slight rocking motion to free the dust cover female connector from the rear connector J1 (4).
 - (c) Check the condition of the insulating sheets in the dust cover and the shield (insulating cover) on top of the switch assembly (10). Replace if necessary.
- (2) Remove front panel and knobs (5).
- (a) Loosen setscrews in the control knobs.
 - (1) Function Selector - 3
 - (2) Bandswitch - 3
 - (3) Volume Control - 2
 - (b) Remove the 3 control knobs. Retain the felt spacer behind each knob.
 - (c) Remove the four screws that secure the front panel assembly to the receiver assembly.
 - (d) Remove the Front Panel Assembly. Complete removal requires disconnecting the MON lamp and taping the wires to prevent shorts if troubleshooting. (Unsolder or cut off if defective.)
- (3) Remove Module assemblies.
- (a) Remove the two screws that secure the r-f shield (8) to the module retaining strap (8). Loosen two screws on bottom of i-f board that attach to the r-f shield.
 - (b) Carefully remove the r-f shield (8) covering the module assemblies. Spread gently to facilitate removal.
 - (c) Remove the two screws that secure the module retaining strap (8) to the chassis.
 - (d) Remove the two screws that secure the Band Selector switch detent to the front of the chassis.
 - (e) Withdraw the detent (13) and the switch shaft from the Receiver Assembly.
 - (f) Unsolder the connecting wires at each module (or the desired module).
 - (g) Remove the module(s) and replace the detent and shaft if all modules are not removed.
- (4) Frequency Selector removal (10).
- (a) Remove the four screws securing the switch assembly (10) to the chassis front. Pull the switch assembly forward about one-half inch.
 - (b) Remove the two upper screws that secure the synthesizer and shield assembly (15) to the chassis divider.

SECTION IV
TROUBLESHOOTING

4-4. B. (4)

- (c) On early production units, snap capacitor C58 out of the clip on the shield assembly (15).
- (d) Loosen the two lower screws that secure the shield assembly (15). Lift shield assembly with attaching cables, clear of frame.
- (e) Remove the three screws that secure the VCO circuit board (6) to the rear of the shield assembly (15).
- (f) Unsolder the single wire between the VCO board (6) and the synthesizer and shield assembly (15).
- (g) With the VCO board clear, carefully lift the Frequency Selector switch and the shield assembly (10) and the synthesizer assembly (15) clear of the chassis. The two assemblies are connected to a harness wired to the chassis. The harness length allows removal of and access to both assemblies.

(5) Synthesizer Removal and Disassembly

NOTE: Step (4) must be performed first.

- (a) Remove the three screws from the left side of the shield assembly (15).
- (b) Separate the shield assembly (15) from the synthesizer (15).
- (c) To disassemble the Synthesizer:
 - (1) Unsolder wire connections as necessary.
 - (2) Remove the three elastic-head nuts from the right side of the right-hand PC Board, Regulator-Detector (2).
 - (3) Withdraw the three hex spacer shafts from the left side of the left-hand PC Board, Counter (11). The three 1/2 inch and three 1/4 inch spacers will fall free. The three PC Boards can now be "fanned out" for access to all components.

(6) Frequency Selector Switch Disassembly

NOTE: It is not necessary to unsolder all four switches in this assembly in order to repair one switch. Separate the individual switches as required, then repair or replace the defective item.

- (a) Remove the four screws securing the lamp contacts, the metal strap and the connecting wire lug to the switch assembly.
- (b) Remove the lamp contacts, lug, strap, retainer and the four lamps. Do not remove the jumper if installed.
- (c) Disconnect the #18 common ground bus from the rear of the switches.

SECTION IV
TROUBLESHOOTING

4-4. B. (6)

- (d) Remove the two screws from each end plate of the switch assembly (10).
- (e) The switch assembly end plates and the four individual switches can now be separated.
- (f) To disassemble any one switch:
 - (1) Perform (5) (a) through (d).
 - (2) Remove the two hex-head screws securing the PC card in place.
 - (3) Separate the PC card from the switch housing.
 - (4) The thumbwheel, contacts and digit dial are integral and are removed by lifting out the unit.
 - (5) Remove the detent spring by lifting it out.

(7) Receiver PC Board (3) Assembly Removal

- (a) Perform Step (1).
- (b) Unsolder connecting leads to metal chassis components.
- (c) Remove the six screws that secure the PC board assembly (3) to the chassis.
- (d) Remove the PC board assembly (3).

NOTE: Replace components only with identical items. See Parts List.

(8) Rear Connector (4) Removal

- (a) Remove dust cover (1) and RF Shield and Retainer Strap (8).
- (b) Unsolder the ground-strap lead between the connector and the inside rear chassis bulkhead.
- (c) Remove the two screws securing the connector to the chassis bulkhead and pull the connector out to gain access to the leads.
- (d) Unsolder leads and remove connector.

4-5. ASSEMBLY PROCEDURE: RECEIVER

A. General

- (1) Certain precautions must be observed during reassembly to ensure proper operation. It is possible to reassembly certain modules/sub-assemblies incorrectly.
- (2) Refer frequently to the Disassembly/Reassembly Guide (Figure 4-1) during reassembly.
- (3) Review Disassembly procedure before commencing assembly.

SECTION IV
TROUBLESHOOTING

B. Procedure

(1) Rear Connector J1 (4)

- (a) Solder the ground strap in place after all other wires are connected and the connector screws have been tightened.

(2) Receiver PC Board TB-5 (3)

- (a) Check for proper clearance between PC board components and the divider bulkhead, the shield assembly (15) and the frequency selector switch assembly (10).
- (b) Complete all soldering before securing the shield assembly (15) and frequency selector switch assembly (10) in place.

(3) Synthesizer Assembly and Shield (15)

- (a) Viewed from the front, the three PC boards in the synthesizer are positioned as follows:

(1) Left-hand: Counter (11) - large cutout at top front. Pins to left.

(2) Center: Clock Offset (16) - crystal at top front, extending to left through large cutout in counter (11). Pins to left.

(3) Right-hand: Regulator Detector (22) - small cutout at bottom front. Pins to right.

CAUTION: AVOID DAMAGING THE PINS ON THESE BOARD.

- (b) Position boards correctly, then insert the three hex-head shafts in the holes in the counter (11).
- (c) Install a half-inch spacer on each hex-hand shaft between the counter (11) and the clock offset (16). Install a quarter-inch spacer on each shaft between the clock-offset (16) and the regulator-detector (22).
- (d) Install an elastic-head nut on each shaft end at the right side of the regulator-detector (22).
- (e) Bring the VCO lead out through the rear of the shield assembly.
- (f) Complete all solder connections to harness.
- (g) Position the synthesizer (15) in the shield assembly (15), aligning the hex-heads with the three holes in the shield assembly.
- (h) Install the three screws through the shield assembly (15) into the synthesizer hex-head shafts and tighten.

NOTE: Make connection to VCO after shield assembly is installed in receiver.

SECTION IV
TROUBLESHOOTING

4-5. B.

(4) Frequency Selector Switch Assembly (10)

(a) Viewed from the back, switch arrangement from left to right is as follows:

- (1) Units - 5 connectors - Labels to right.
- (2) Tens - 6 connectors - Labels to right.
- (3) Hundreds - 9 connectors - Labels to right.
- (4) Thousands - 6 connectors - Labels to right.

NOTE: (4) has gold foil contacts on right side only. Front panel displays only numeral 1.

(b) Assemble switches and end plates. Notched end-plate is to left viewed from the front.

(c) Insert the two shafts, then install and tighten the two screws at each end of each shaft.

(d) Install the common ground lead (# 18 wire) and solder to each terminal.

(e) Connect and solder the leads between shield assembly (15), the switch assembly (10) and the harness.

(f) Install lamps and connect for 14V or 28V as required (see Figure 6-1).

(g) Position the complete assembly in place arranging the harness as shown in Figure 6-2. Install the two front screws that secure the shield assembly to the chassis bulkhead.

(h) Install the rear screws in the synthesizer assembly (15).

(i) Connect and solder the lead between the VCO from the shield assembly.

(j) Install the four screws securing the switch assembly (10) to the chassis front.

(5) Module Assemblies

(a) Ensure that the switch wafer position is the same in all modules.

(b) Modules are installed (front to rear) as follows: loop, r-f, VCO, mixer, with the switch wafers facing the front panel.

(c) Position and connect each module, then carefully install the bandswitch detent (13) and shaft from the chassis front through each module.

(d) Install and tighten the two screws securing the bandswitch detent (13) to the front panel side of the chassis.

SECTION IV
TROUBLESHOOTING

4-5. B. (5)

- (e) Replace the module retaining strap (8) and install the rear and the center screws.

NOTE: The coaxial input lead and all modules must be properly positioned.

- (f) Install the r-f shield (8). The side with the capacitor labels must be up. Install the two screws through the r-f shield (8) into the module retaining strap (8). The edge of the r-f shield must be slipped under the heads of two screws on the bottom of the i-f board and then the screws must be tightened.

(6) Front Panel And Knobs (5)

- (a) The monitor lamp (9) if removed, must be installed through the panel.
- (b) Place a spacer over each corner hole in the front chassis wall, then put the panel (5) in place.
- (c) Install the four retaining screws.
- (d) Place the felt spacers over the function selector switch (7), band switch (13), and volume control shafts (22).
- (e) Replace the VOL knob the band selector and function selector knobs (5). Tighten one setscrew in each.
- (f) Check knob movement (VOL travel is 270°). Adjust as necessary, then tighten all setscrews.

(7) Dust Cover (1)

- (a) Install. Slot for retaining cam must be at upper left. Press cover firmly into place to seat connector.
- (b) Tighten retaining cam using Phillips screwdriver (through hole at upper left of digital switch assembly).

4-6. DISASSEMBLY PROCEDURE: 551A SERVO AMP-INDICATOR (See figure 5-3).

A. Remove dust cover (1)

- (1) Remove two screws that hold dust cover to chassis assembly (23).
- (2) Remove dust cover from servo amp-indicator assembly.

B. Remove front indicator bezel assembly (2) from mounting plate (17).

- (1) Remove three screws and three washers, that secure indicator bezel assembly (2) to mounting plate (17).
- (2) Pull indicator bezel assembly (2) away from mounting plate (17). Chassis assembly (23) will be freed from its mounting place.

SECTION IV
TROUBLESHOOTING

4-6.

C. Remove r-f resolver (19).

- (1) Remove two screws, two washers, and two mounting clamps (20) that fasten resolver to mounting plate (17).
- (2) Remove resolver (19) by first loosening the two set screws in gear (18).

D. Remove motor (8).

- (1) Remove two screws securing motor to mounting plate (17).
- (2) Withdraw motor.

E. Remove glass assembly (3).

Release retaining ring (4) and carefully withdraw glass (3) and frame gasket (5) and bezel (2).

F. Remove pointer (7).

Remove pointer from gear shaft (19) by means of gear extracting tool. Pointer (7) is press fitted on shaft of motor (19) and may be removed by using a suitable gear extracting tool.

G. Remove dial (6).

- (1) Remove two screws that secure dial to mounting plate (17).
- (2) Withdraw dial.

H. Remove Gears (13) and (9).

- (1) Withdraw spur reduction gear (13) by removing washer (16), washer (15) and retaining ring (14).
- (2) Carefully withdraw reduction gear (13) from mounting plate (17).
- (3) Withdraw spur reduction gear (9) from mounting plate (17) by removing washer (12) spacer (11) and retaining ring (10).

4-7. DISASSEMBLY PROCEDURE: 551B REMOTE SERVO AMPLIFIER (See figure 5-4).

A. Remove dust cover (1).

- (1) Remove two screws that hold dust cover to chassis assembly (26).
- (2) Remove dust cover from servo amplifier assembly.

B. Remove r-f resolver (20).

- (1) Remove three screws that secure chassis assembly (26) to mounting plate (19).

SECTION IV
TROUBLESHOOTING

4-7. B.

- (2) Pull chassis assembly away from mounting plate and remove two screws, two washers, and two mounting clamps (21) that fasten resolver to mounting plate (19).
- (3) Remove resolver (20) by first loosening the two set screws (each) in gears (22) and (23).

C. Remove motor (10).

- (1) Remove two screws securing motor to mounting plate (19).
- (2) Withdraw motor.

D. Remove synchro transmitter (7).

NOTE: Neither r-f resolver (20) nor motor (10) need be removed in order to remove synchro (7).

- (1) Remove two screws that hold dust cover (4) to the posts attached to mounting plate (19).
- (2) Pull dust cover (4) away from bezel (2) and remove two screws, two washers, and two mounting clamps (8) that fasten synchro to mounting plate (6).
- (3) Remove synchro by first loosening the two setscrews in gear (9).

E. Remove gears (15) and (11).

- (1) Remove two posts securing mounting plate (6) to mounting plate (19) and withdraw mounting plate (6).
- (2) Withdraw spur reduction gear (15) by removing washer (18), washer (17) and retaining ring (16).
- (3) Withdraw spur reduction gear (11) from mounting plate (19) by removing washer (14) spacer (13) and retaining ring (12).

4-8. DISASSEMBLY PROCEDURE: 551C DUAL SYNCHRO INDICATOR (See figure 5-5).

A. Remove dust cover (1).

- (1) Remove two screws that hold dust cover to frame (15).
- (2) Remove dust cover from synchro indicator assembly.

B. Remove synchro (14).

- (1) Remove three screws that secure frame (15) and synchro (14) to housing (11).
- (2) Loosen setscrew in coupling (13).
- (3) Withdraw frame (15) and synchro (14) from housing (11).
- (4) Remove three screws securing synchro (14) to frame (15).
- (5) Withdraw synchro (14).

SECTION IV
TROUBLESHOOTING

4-8. B.

NOTE: Indicator bezel assembly (2), glass (3), gasket (4), pointers (5) and (6), dial (7) spacer (8), filler (9) and synchro (10) need not be removed unless one of these parts is to be replaced.

C. Remove front indicator bezel assembly (2) from housing (11).

- (1) Remove eight screws that secure indicator bezel assembly (2) to housing (11).
- (2) Pull indicator bezel assembly (2) away from housing (11). Glass (3) and gasket (4) will be freed.

D. Remove pointers (5) and (6).

Remove pointers from shafts by means of gear extracting tool. Pointers are press fitted on shafts and may be removed by using a suitable gear extracting tool.

E. Remove dial (7), spacer (8) and filler (9).

- (1) Remove two screws that secure dial to filler plate (9).
- (2) Withdraw dial and spacer.
- (3) Remove four screws that secure filler plate to housing (11).
- (4) Withdraw filler plate.

F. Remove synchro (10).

- (1) Remove all assemblies in paragraphs A through E above.
- (2) Remove shaft (12) and coupling (13) from synchro (10).
- (3) Remove three screws securing synchro (10) to housing (11).
- (4) Withdraw synchro (10).

4-9. DISASSEMBLY PROCEDURE: 551E SERVO AMP-INDICATOR (See Figure 5-6).

A. Remove dust cover (1).

- (1) Remove two screws that hold dust cover to chassis assembly (24).
- (2) Remove dust cover from servo amp-indicator assembly.

B. Remove synchro transmitter (25).

- (1) Remove three screws and three washers that secure chassis assembly (24) to posts behind gear plate (27).
- (2) Loosen setscrew in coupler (21).
- (3) Remove two synchro mounting clamps (26).
- (4) Withdraw synchro (25).

SECTION IV
TROUBLESHOOTING

4-8. C.

C. Remove r-f resolver (19).

- (1) Remove two screws, two washers, and two mounting clamps (20) that fasten resolver to mounting plate (17).
- (2) Remove resolver (19) by first loosening the two set screws in gear (18).

D. Remove motor (8).

- (1) Remove two screws securing motor to mounting plate (17).
- (2) Withdraw motor.

E. Remove front indicator bezel assembly (2) from mounting plate (17).

- (1) Remove three posts that secure indicator bezel assembly (2) to mounting plate (17).
- (2) Pull indicator bezel assembly (2) away from mounting plate (17).

F. Remove glass assembly (3).

Release retaining ring (4) and carefully withdraw glass (3) and frame gasket (5) and bezel (2).

G. Remove pointer (7).

Remove pointer from gear shaft (19) by means of gear extracting tool. Pointer (7) is press fitted on shaft of motor (19) and may be removed by using any suitable gear extracting tool.

H. Remove dial (6).

- (1) Remove two screws that secure dial to mounting plate (17).
- (2) Withdraw dial.

I. Remove gears (13) and (9).

- (1) Withdraw spur reduction gear (13) by removing washer (16), washer (15) and retaining ring (14).
- (2) Carefully withdraw reduction gear (13) from mounting plate (17).
- (3) Withdraw spur reduction gear (9) from mounting plate (17) by removing washer (12) spacer (11) and retaining ring (10).

SECTION IV
TROUBLESHOOTING

4-10. DISASSEMBLY PROCEDURE: 551RL SERVO AMPLIFIER -- INDICATOR

A. The procedure for the 551RL is similiar to the procedure for the 551A, however for lens or lamp replacement proceed as follows:

- (1) Remove azimuth control knob.
- (2) Remove three screws on face of instrument and lift off the retaining mask assembly.
- (3) Remove four small screws holding the indice plate on the rear of the retaining mask assembly.
- (4) Lift off the indice plate and contact ring assembly.
- (5) The indicator lamps are mounted on the contact ring assembly.

CAUTION

LEAD LENTHS MUST ALLOW LAMPS TO LOCATE
IN THE LENS RECESS.

B. To remove azimuth dial and gear plate assembly:

- (1) Remove azimuth control knob.
- (2) Remove two screws holding dust cover, and withdraw unit from dust cover.
- (3) Remove three holding screws from rear of front bezel assembly.
- (4) Hold the azimuth control shaft and lift off the entire front bezel assembly.

CAUTION

THE AZIMUTH CONTROL SHAFT IS NOT CAPTIVE
IN THE FRONT BEZEL ASSEMBLY; AND WILL DROP
OUT IF NOT HELD;

- (5) Remove pointer assembly.
- (6) Remove two screws holding the azimuth dial.
- (7) Remove two screws holding the gear plate assembly to posts on the motor and gear train assembly.

SECTION IV
TROUBLESHOOTING

4-11. ASSEMBLY PROCEDURE: SERVO AMPLIFIER-INDICATOR

A. Assembly procedures are the reverse of disassembly procedures with the exception of the following special instructions.

(1) Mounting screws.

Apply glyptal (G. E. type 1276 or equivalent) to all threaded fasteners where there are no other locking devices.

(2) Gasket

Secure gasket in place with pliobond adhesive if necessary.

(3) Gears

(a) If found necessary, apply a few drops of light instrument oil to felt washers between gears.

(b) Make certain gears engage smoothly upon replacement.

(4) Pointer

(a) Tap pointer lightly until adequate fit is attained on shaft of rf resolver.

Document is protected
Not for re-sale
For informational use
only

**SECTION V.
PARTS LISTS**

5-1. GENERAL

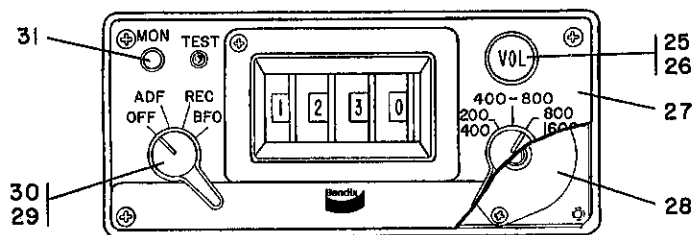
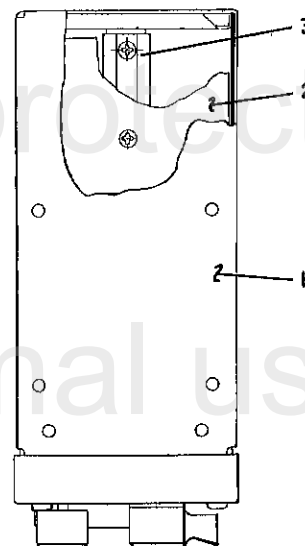
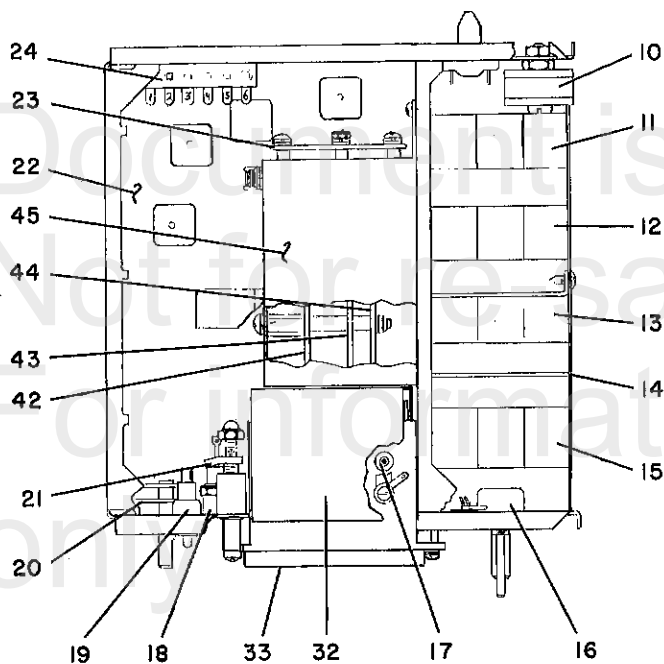
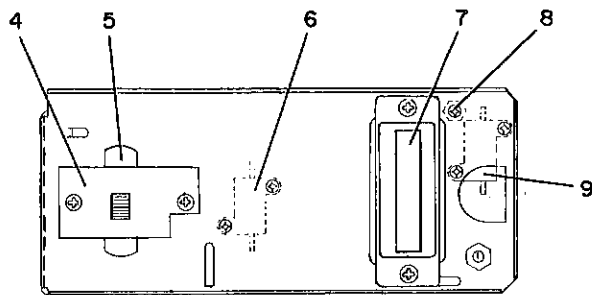
This section contains electrical and mechanical parts lists for the various equipments employed in the ADF-T12D System. Each list is identified by the type number of the equipment covered.

Illustrations are provided only as an aid to locate and identify replaceable parts. Refer to applicable diagrams, Section VI of this manual, for any electrical parts not appearing on parts list illustrations.

Document is protected
Not for re-sale
For informational use
only

Bendix Avionics Division

**SECTION V.
PARTS LISTS**



201F ADF Receiver Assembly
Figure 5-1

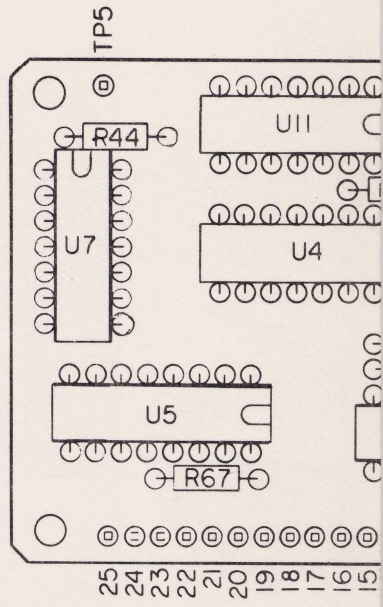
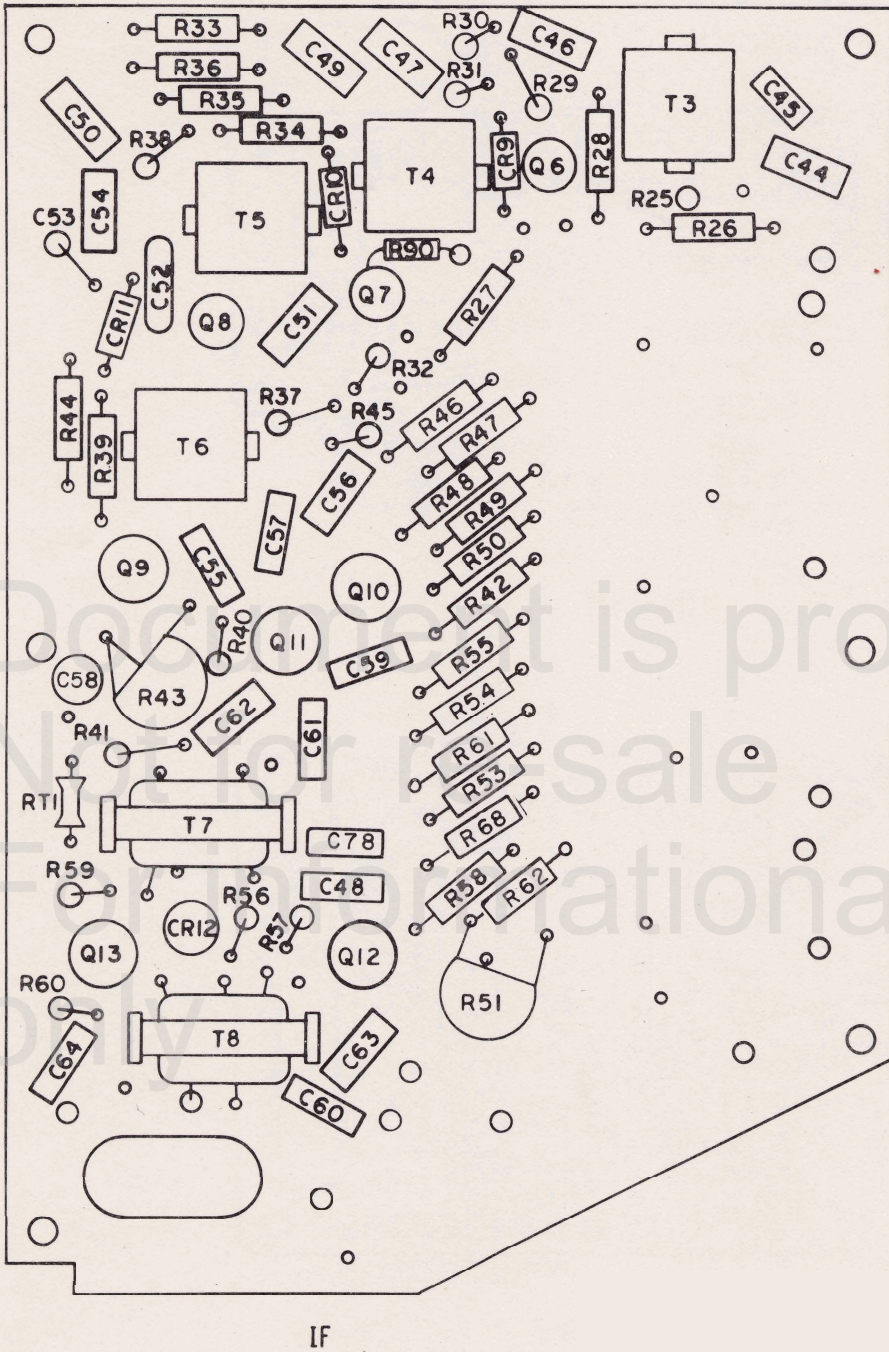
Bendix Avionics Division

SECTION V.
PARTS LISTS
 201F ADF RECEIVER
 MECHANICAL PARTS LIST

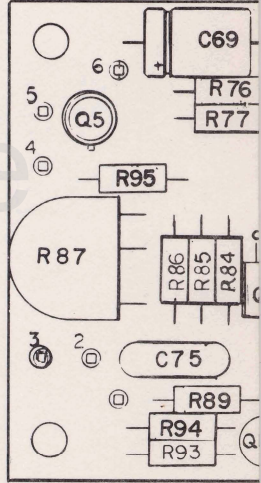
REF DESIG	FIG ITEM	DESCRIPTION	BENDIX PART NUMBER
5-1		RECEIVER ASSEMBLY, GENERAL	
	1	COVER, RECEIVER	60D015-0002
	2	SHIELD, RF MODULE	60C014-0002
	3	STRAP, MODULE RETAINING	62B025-0001
	4	KEY, VOLTAGE SWITCH	63A038-0001
S8	5	SWITCH, SLIDE	22013-0003
R69	6	RESISTOR, POWER	11146-0012
J1	7	CONNECTOR	24045-016P
	8	TERMINAL, STANDOFF	32003-0001
R67	9	RESISTOR, POWER	11146-0012
L14	10	CHOKER, FILTER	17314-0001
	11	MIXER MODULE ASSEMBLY	4007016-0501
	12	OSCILLATOR MODULE ASSEMBLY -VCO-	4007014-0501
	13	RF MODULE ASSEMBLY	4007019-0501
	14	.BALANCED MODULATOR ASSEMBLY	4007017-0501
	15	LOOP MODULE ASSEMBLY	4007015-0501
R52	16	RESISTOR, VARIABLE	11145-0001
DS1-4	17	LAMP, INCANDESCENT	21010-0001
CR13	18	DIODE, ZENER	12043-0017
S6	19	SWITCH, PUSH BUTTON	22020-0003
S7	20	SWITCH, ROTARY	22014-0001
	21	LATCH	4002348-0002
TB5	22	IF P.C. BOARD ASSEMBLY	4007119-0501
TB4	23	VCO P.C. BOARD ASSEMBLY	4006990-0502
TB6	24	STRIP, TERMINAL	32044-0003
	25	KNOB, VOLUME	75C005-0004
	26	WASHER, FELT	36016-0003
	27	FRONT PANEL	4004467-0001
	28	DETENT ASSEMBLY BAND SWITCH	918002-0001
	29	KNOB, LEVER -2EA- FUNCTION OR BAND SELECTOR	758006-0001
	30	WASHER, FELT -2EA-	36016-0001
	31	LIGHT, INDICATOR, MONITOR	21037-0204
		SYNTHESIZER ASSEMBLY	
	32	INSULATOR, SWITCH MODULE	4004523-0001
	33	THUMBWHEEL SWITCH ASSEMBLY	4004469-0001
	34	.LEFT END PLATE	4004469-0002
	35	.RIGHT END PLATE	4004469-0007
	36	.SWITCH MODULE, 1MHZ	4004469-0003
	37	.SWITCH MODULE, 100KHZ	4004469-0004
	38	.SWITCH MODULE, 10KHZ	4004469-0005
	39	.SWITCH MODULE, 1KHZ	4004469-0006
	40	.HARDWARE SET -4 SCREWS, 2 SPACERS-	4004469-0008
	41	.LIGHTING SET -4 SCREWS, 2 STRAPS, 4 TABS, AND 1 STRIP	4004469-0009
TB1	42	COUNTER ASSEMBLY	4006985-0501
TB2	43	CLOCK OFFSET ASSEMBLY	4006983-0501
TB3	44	REGULATOR-DETECTOR ASSEMBLY	4006981-0501
	45	SHIELD ASSEMBLY	4006986-0501

Bendix Avionics Division

SECTION V.
PARTS LISTS



COUNTER



VCO

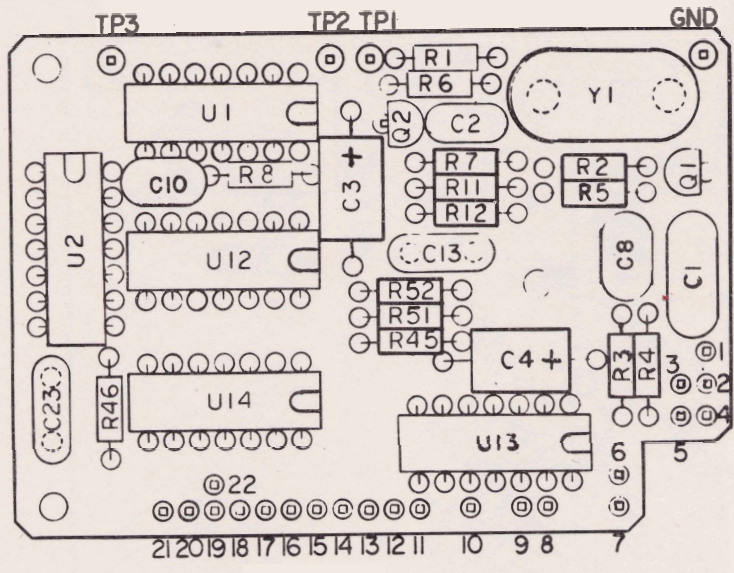
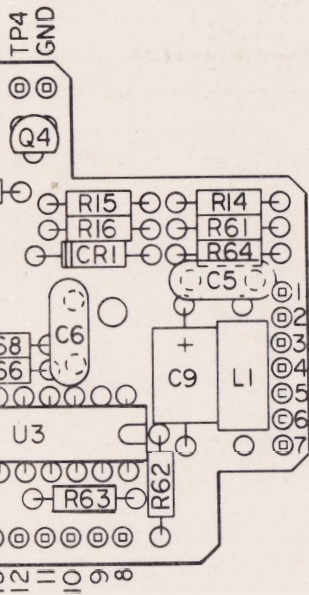
M3608250

201F ADF Receiver, P.C. Boards
Figure 5-2

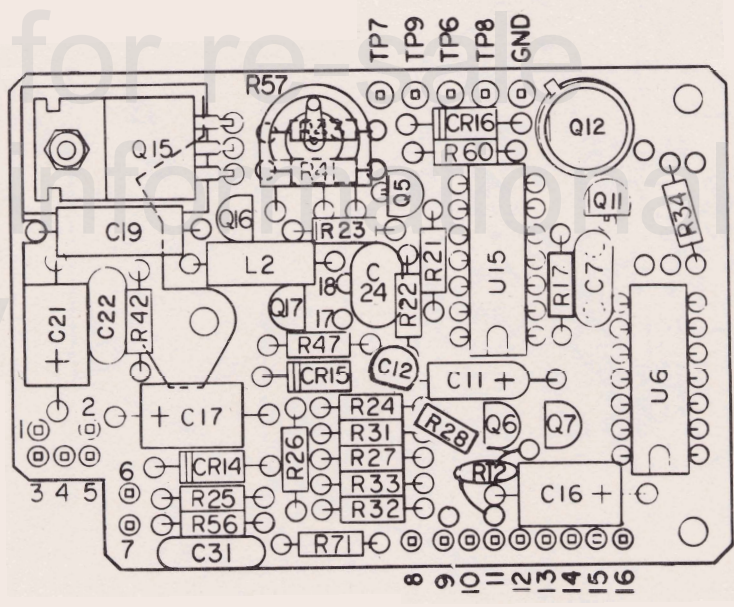
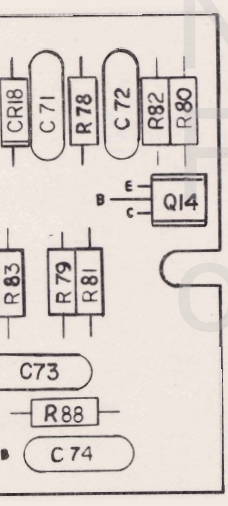
Bendix Avionics Division

I. B. 2012B

5-5/5-6
Revised Dec/72



CLOCK-OFFSET



REGULATOR-DETECTOR

WARNING

This manual which you have requested is furnished for general information purposes only. Service bulletins which supplement this manual are only furnished to Bendix authorized FAA approved repair stations. DO NOT USE THIS MANUAL FOR EFFECTUATING REPAIRS OF THE EQUIPMENT.

SECTION V.
PARTS LISTS
201F ADF RECEIVER
ELECTRICAL PARTS LIST

REF DESIG	DESCRIPTION	BENDIX PART NUMBER
01-99	RECEIVER ASSEMBLY, GENERAL	
	CAPACITORS	
C1	0.047UF P/M10% 50VDC POLYESTER	10171-0006
C3	5 TO 30PF 350VDC TRIMMER	10115-0005
C4	5 TO 30PF 350VDC TRIMMER	10115-0005
C5	68PF P/M2% 500VDC MICA	10205-0235
C6	5 TO 30PF 350VDC TRIMMER	10115-0005
C7	56PF P/M2% 500VDC MICA	10205-0236
C8	0.1UF P/M10% 50VDC POLYESTER	10171-0002
C9	0.1UF P/M10% 50VDC POLYESTER	10171-0002
C10	560PF P/M2% 100VDC MICA	10206-0275
C10	330PF P/M2% 100VDC MICA	10205-0232
	EFFECTIVE S/N1210 AND ABOVE	
C10	560PF P/M5% 300VDC MICA	10205-0490
	EFFECTIVE MOD 7 S/N7263	
C11	160PF P/M2% 500VDC MICA	10205-0233
C11	120PF P/M2% 500VDC MICA	10205-0210
	EFFECTIVE S/N1210 AND ABOVE	
C11	270PF P/M5% 100VDC MICA	10205-0466
	EFFECTIVE MOD 7 S/N7263	
C12	100PF P/M2% 500VDC MICA	10205-0216
C12	68PF P/M2% 500VDC MICA	10205-0235
	EFFECTIVE S/N1210 AND ABOVE	
C13	240PF P/M2% 100VDC MICA	10205-0285
C14	0.1UF P/M10% 50VDC POLYESTER	10171-0002
C15	0.1UF P80M20% 12VDC DISC	10198-0015
C16	0.047UF P/M10% 50VDC POLYESTER	10171-0006
C17	5 TO 30PF 350VDC TRIMMER	10115-0005
C19	5 TO 30PF 350VDC TRIMMER	10115-0005
C20	8PF P/M5% 500VDC MICA	10205-0404
C21	90PF P/M5% 500VDC MICA	10205-0420
	EFFECTIVE S/N1001 AND ABOVE	
C21	68PF P/M5% 500VDC MICA	10205-0435
	EFFECTIVE S/N1166 AND ABOVE	
C21	SELECTED VALUE, REPLACE WITH SAME VALUE	
	EFFECTIVE S/N1601 AND ABOVE	
C22	8 TO 50PF 350VDC TRIMMER	10115-0006
C23	0.01UF P/M10% 50VDC POLYESTER	10171-0010
C24	5 TO 30PF 350VDC TRIMMER	10115-0005
C25	10PF P/M2% 500VDC MICA	10205-0205
C26	5 TO 30PF 350VDC TRIMMER	10115-0005
C28	5 TO 30PF 350VDC TRIMMER	10115-0005
C30	0.015UF P/M10% 50VDC POLYESTER	10171-0003
C31	0.1UF P/M10% 50VDC POLYESTER	10171-0002
C32	82PF P/M2% 500VDC MICA	10205-0247
C33	56PF P/M2% 500VDC MICA	10205-0236
	EFFECTIVE S/N1001 AND ABOVE	
C34	47PF P/M2% 500VDC MICA	10205-0226
C35	925PF P/M2% 100VDC MICA	10205-0274
C36	3000PF P/M2% 500VDC MICA	10206-0264
C37	1800PF P/M2% 500VDC MICA	10206-0235
C39	5 TO 30PF 350VDC TRIMMER	10115-0005
C39	8 TO 50PF 350VDC TRIMMER	10115-0006
	EFFECTIVE S/N2513 AND ABOVE	
C41	5 TO 30PF 350VDC TRIMMER	10115-0005
C41	8 TO 50PF 350VDC TRIMMER	10115-0006
	EFFECTIVE S/N2513 AND ABOVE	

Bendix Avionics Division

SECTION V.
PARTS LISTS
201F ADF RECEIVER
ELECTRICAL PARTS LIST

REF DESIG	DESCRIPTION	BENDIX PART NUMBER
C43	5 TO 30PF 350VDC TRIMMER	10115-0005
C43	8 TO 50PF 350VDC TRIMMER	10115-0006
	EFFECTIVE S/N2513 AND ABOVE	
C44	0.1UF P/M10% 50VDC POLYESTER	10171-0002
C45	10UF P/M20% 15VDC TANTALUM	10183-10R15
C46	0.1UF P/M10% 50VDC POLYESTER	10171-0002
C47	0.1UF P/M10% 50VDC POLYESTER	10171-0002
C48	39UF P/M20% 15VDC TANTALUM	10183-39R15
C49	0.1UF P/M10% 50VDC POLYESTER	10171-0002
C50	0.1UF P/M10% 50VDC POLYESTER	10171-0002
C51	0.47UF P/M10% 50VDC POLYCARBONATE	10171-0004
C52	751PF P/M10% 300VDC SILVERED-MICA	10087-C751K3
C53	1.0UF P/M20% 20VDC TANTALUM	2088201-0003
C54	0.1UF P/M10% 50VDC POLYESTER	10171-0002
C55	39UF P/M20% 15VDC TANTALUM	10183-39R15
C56	0.1UF P/M10% 50VDC POLYESTER	10171-0002
C57	10UF P/M20% 15VDC TANTALUM	10183-10R15
C58	1000UF P100M10% 10VDC ELECTROLYTIC	10049-0001
C59	0.022UF P/M10% 50VDC POLYESTER	10171-0005
C60	2.2UF P/M20% 10VDC TANTALUM	10183-2R210
C61	6.8UF P/M20% 15VDC TANTALUM	10183-6R815
C62	0.047UF P/M10% 50VDC POLYESTER	10171-0006
C63	0.047UF P/M10% 50VDC POLYESTER	10171-0006
C64	0.047UF P/M10% 50VDC POLYESTER	10171-0006
C65	27PF P/M5% 300VDC MICA	10205-0458
C65	SELECTED VALUE, REPLACE WITH SAME VALUE	
	EFFECTIVE S/N5295 AND ABOVE	
C68	75PF P/M2% 500VDC MICA	10205-0246
C69	22UF P50M10% 16VDC ELECTROLYTIC	10227-0031
C71	0.1UF P80M20% 12VDC DISC	10198-0015
C72	0.1UF P80M20% 12VDC DISC	10198-0015
C73	0.1UF P80M20% 12VDC DISC	10198-0015
C74	0.1UF P80M20% 12VDC DISC	10198-0015
C75	24PF P/M5% 500VDC MICA	10205-0465
C76	100UF P150M10% 50VDC ELECTROLYTIC	10111-0007
C77	0.047UF P/M10% 50VDC POLYESTER	10171-0006
C78	39UF P/M20% 15VDC TANTALUM	10183-39R15
C79	SELECTED VALUE, REPLACE WITH SAME VALUE	
C80	0.1UF P80M20% 12VDC DISC	10198-0015
DIODES		
CR1	GERMANIUM JUNCTION	12004-0001
CR1	1N914 EFFECTIVE S/N2475 AND ABOVE	12040-0003
CR2	GERMANIUM JUNCTION	12004-0001
CR2	1N914 EFFECTIVE S/N2475 AND ABOVE	12040-0003
CR3	GERMANIUM JUNCTION	12004-0001
CR3	1N914 EFFECTIVE S/N2475 AND ABOVE	12040-0003
CR4	GERMANIUM JUNCTION	12004-0001
CR4	1N914 EFFECTIVE S/N2475 AND ABOVE	12040-0003
CR5	GERMANIUM JUNCTION	12004-0001
CR5	1N117 EFFECTIVE S/N2883 AND ABOVE	12041-0037
CR7	GERMANIUM JUNCTION DELETED EFF. S/N2850 AND ABOVE	12004-0001
CR9	GERMANIUM JUNCTION	12004-0001
CR9	1N117 EFFECTIVE S/N2883 AND ABOVE	12041-0037
CR10	GERMANIUM JUNCTION	12004-0001
CR10	1N117 EFFECTIVE S/N2883 AND ABOVE	12041-0037
CR11	GERMANIUM JUNCTION	12004-0001

Bendix Avionics Division

SECTION V.
PARTS LISTS
 201F ADF RECEIVER
 ELECTRICAL PARTS LIST

REF DESIG	DESCRIPTION	BENDIX PART NUMBER
CR11	1N117 EFFECTIVE S/N2883 AND ABOVE	12041-0037
CR12	1N2326	12002-0063
CR13	1N2973A ZENER	12043-0017
CR14-17 & CR19	MATCHED SET OF VVC DIODES -INCLUDES CR14, CR15, CR16, CR17, CR19	4007018-0501
CR18	1N748A ZENER	12043-0055
CR20	1N4003	12042-0031
CR21	1N4003 DELETED EFF. S/N2850 AND ABOVE	12042-0031
CR22	1N914 ADDED EFF MOD 6 S/N6602	12040-0003
CR23	1N914 ADDED EFF MOD 6 S/N6602	12040-0003
LAMPS		
DS1	INCANDESCENT 14V	21010-0001
DS2	INCANDESCENT 14V	21010-0001
DS3	INCANDESCENT 14V	21010-0001
DS4	INCANDESCENT 14V	21010-0001
JACKS		
J1	RIBBON 16 CONTACTS	24045-016P
INDUCTORS		
L1	RF COIL ASSEMBLY	900029-0001
L2	RF COIL ASSEMBLY	900029-0005
L3	RF COIL ASSEMBLY	900029-0009
L4	RF COIL ASSEMBLY	900029-0002
L5	RF COIL ASSEMBLY	900029-0006
L6	RF COIL ASSEMBLY	900029-0010
L7	RF COIL ASSEMBLY	900029-0013
L8	RF COIL ASSEMBLY	900029-0015
L9	RF COIL ASSEMBLY	900029-0017
L10	RF COIL ASSEMBLY	900029-0016
L11	RF COIL ASSEMBLY	900029-0008
L12	RF COIL ASSEMBLY	900029-0012
L13	10MH P/M10% FERRITE	17019-0062
L14	FILTER CHOKE	17314-0001
TRANSISTORS		
Q1	2N1637 PNP GERMANIUM	12045-0020
Q1	MPS6516 EFFECTIVE S/N2883 AND ABOVE	12048-0015
Q2	2N1637 PNP GERMANIUM	12045-0020
Q2	MPS6516 EFFECTIVE S/N2883 AND ABOVE	12048-0015
Q3	2N1637 PNP GERMANIUM	12045-0020
Q3	MPS6516 EFFECTIVE S/N2883 AND ABOVE	12048-0015
Q4	2N1637 PNP GERMANIUM	12045-0020
Q4	MPS6516 EFFECTIVE S/N2883 AND ABOVE	12048-0015
Q5	NF500 FET	12050-0024
Q6	2N1638	12001-0056
Q6	MPS6516 EFFECTIVE S/N2883 AND ABOVE	12048-0015
Q7	2N1638	12001-0056
Q7	MPS6516 EFFECTIVE S/N2883 AND ABOVE	12048-0015
Q8	2N1638	12001-0056
Q8	MPS6516 EFFECTIVE S/N2883 AND ABOVE	12048-0015
Q9	2N1304	12001-0053
Q10	2N1193	12001-0064

Bendix Avionics Division

SECTION V.
PARTS LISTS
201F ADF RECEIVER
ELECTRICAL PARTS LIST

REF DESIG	DESCRIPTION	BENDIX PART NUMBER
Q11	SA279	12001-0072
Q12	SA279	12001-0072
Q13	SA279	12001-0072
Q14	SPS-938 NPN SILICON	12047-0072
Q15	SPS-938 NPN SILICON	12047-0072
Q16	SPS-938 NPN SILICON	12047-0072
RESISTORS		
R1	3.3K OHMS P/M5% 1/4W COMPOSITION	RC07GF332J
R2	3.3K OHMS P/M5% 1/4W COMPOSITION	RC07GF332J
R3	82 OHMS P/M5% 1/4W COMPOSITION	RC07GF820J
R4	4.7K OHMS P/M5% 1/4W COMPOSITION	RC07GF472J
R4	3K OHMS P/M5% 1/4W COMPOSITION EFFECTIVE S/N2883 AND ABOVE	RC07GF302J
R5	3.9K OHMS P/M5% 1/4W COMPOSITION	RC07GF392J
R5	2.7K OHMS P/M5% 1/4W COMPOSITION EFFECTIVE S/N2850 AND ABOVE	RC07GF272J
R6	3.9K OHMS P/M5% 1/4W COMPOSITION	RC07GF392J
R6	2.7K OHMS P/M5% 1/4W COMPOSITION EFFECTIVE S/N2850 AND ABOVE	RC07GF272J
R7	3.3K OHMS P/M5% 1/4W COMPOSITION	RC07GF332J
R8	3.3K OHMS P/M5% 1/4W COMPOSITION	RC07GF332J
R9	1K OHMS P/M5% 1/4W COMPOSITION	RC07GF102J
R10	47K OHMS P/M5% 1/4W COMPOSITION	RC07GF473J
R11	2.2K OHMS P/M5% 1/4W COMPOSITION	RC07GF222J
R12	10K OHMS P/M5% 1/4W COMPOSITION	RC07GF103J
R13	10K OHMS P/M5% 1/4W COMPOSITION	RC07GF103J
R14	27K OHMS P/M5% 1/4W COMPOSITION	RC07GF273J
R15	68K OHMS P/M5% 1/4W COMPOSITION	RC07GF683J
R16	27K OHMS P/M5% 1/4W COMPOSITION	RC07GF273J
R17	15K OHMS P/M5% 1/4W COMPOSITION	RC07GF153J
R17	22K OHMS P/M5% 1/4W COMPOSITION EFFECTIVE S/N2850 AND ABOVE	RC07GF223J
R17	15K OHMS P/M5% 1/4W COMPOSITION EFFECTIVE S/N2883 AND ABOVE	RC07GF153J
R18	10K OHMS P/M5% 1/4W COMPOSITION DELETED EFF. S/N2850 AND ABOVE	RC07GF103J
R19	120K OHMS P/M5% 1/4W COMPOSITION DELETED EFF. S/N2850 AND ABOVE	RC07GF124J
R20	470K OHMS P/M5% 1/4W COMPOSITION ADDED EFFECTIVE S/N5868 AND ABOVE	RC07GF474J
R21	270K OHMS P/M5% 1/4W COMPOSITION ADDED EFFECTIVE S/N5868 AND ABOVE	RC07GF274J
R22	3.3 OHMS P/M5% 1/4W COMPOSITION ADDED EFFECTIVE S/N2883 AND ABOVE	RC07GF3R3J
R23	560K OHMS P/M5% 1/4W COMPOSITION	RC07GF564J
R24	270K OHMS P/M5% 1/4W COMPOSITION ADDED EFFECTIVE S/N5868 AND ABOVE	RC07GF274J
R25	47K OHMS P/M10% 1/2W COMPOSITION	RC20GF473K
R26	2.2K OHMS P/M10% 1/2W COMPOSITION	RC20GF222K
R27	10K OHMS P/M10% 1/2W COMPOSITION	RC20GF103K
R28	10K OHMS P/M10% 1/2W COMPOSITION	RC20GF103K
R29	22K OHMS P/M10% 1/2W COMPOSITION	RC20GF223K
R30	47K OHMS P/M10% 1/2W COMPOSITION	RC20GF473K
R31	2.2K OHMS P/M10% 1/2W COMPOSITION	RC20GF222K
R32	10K OHMS P/M10% 1/2W COMPOSITION	RC20GF103K
R33	10K OHMS P/M10% 1/2W COMPOSITION	RC20GF103K
R34	56K OHMS P/M10% 1/2W COMPOSITION	RC20GF563K
R35	6.8K OHMS P/M10% 1/2W COMPOSITION	RC20GF682K
R35	3.9K OHMS P/M10% 1/2W COMPOSITION EFFECTIVE S/N2883 AND ABOVE	RC20GF392K

Bendix Avionics Division

SECTION V.
PARTS LISTS
201F ADF RECEIVER
ELECTRICAL PARTS LIST

REF DESIG	DESCRIPTION	BENDIX PART NUMBER
R36	1K OHMS P/M10% 1/2W COMPOSITION	RC20GF102K
R37	330 OHMS P/M10% 1/2W COMPOSITION	RC20GF331K
R38	6.8K OHMS P/M10% 1/2W COMPOSITION	RC20GF682K
R39	15K OHMS P/M10% 1/2W COMPOSITION	RC20GF153K
R40	1K OHMS P/M10% 1/2W COMPOSITION	RC20GF102K
R41	4.7K OHMS P/M10% 1/2W COMPOSITION DELETED EFF. S/N2083 AND ABOVE	RC20GF472K
R42	8.2K OHMS P/M10% 1/2W COMPOSITION	RC20GF822K
R43	25K OHMS P/M30% TRIMMER	11058-0005
R44	150 OHMS P/M10% 1/2W COMPOSITION	RC20GF151K
R45	2.2K OHMS P/M10% 1/2W COMPOSITION	RC20GF222K
R46	1K OHMS P/M10% 1/2W COMPOSITION	RC20GF102K
R47	33K OHMS P/M10% 1/2W COMPOSITION	RC20GF333K
R48	10K OHMS P/M10% 1/2W COMPOSITION	RC20GF103K
R49	820 OHMS P/M10% 1/2W COMPOSITION	RC20GF821K
R50	1K OHMS P/M10% 1/2W COMPOSITION	RC20GF102K
R51	2K OHMS P/M30% TRIMMER	11058-0002
R51	500 OHMS P/M30% 250VDC CERAMIC EFFECTIVE S/N5295 AND ABOVE	11058-0001
R52	50K OHMS P/M10% 1W VARIABLE	11145-0001
R53	6.8K OHMS P/M10% 1/2W COMPOSITION	RC20GF682K
R54	270 OHMS P/M10% 1/2W COMPOSITION	RC20GF271K
R55	27 OHMS P/M10% 1/2W COMPOSITION	RC20GF270K
R56	1.5K OHMS P/M10% 1/2W COMPOSITION	RC20GF152K
R57	47K OHMS P/M10% 1/2W COMPOSITION	RC20GF473K
R58	10 OHMS P/M10% 1/2W COMPOSITION	RC20GF100K
R59	10 OHMS P/M10% 1/2W COMPOSITION	RC20GF100K
R60	47K OHMS P/M10% 1/2W COMPOSITION	RC20GF473K
R61	270 OHMS P/M5% 1/2W COMPOSITION ADDED EFFECTIVE S/N1601 AND ABOVE	RC20GF271J
R62	10K OHMS P/M10% 1/2W COMPOSITION	RC20GF103K
R66	20 OHMS P/M10% 3W WW	11040-200K
R67	12 OHMS P/M3% 10W WW	11146-0012
R68	22 OHMS P/M10% 1/2W COMPOSITION	RC20GF220K
R69	12 OHMS P/M3% 10W WW	11146-0012
R71	470K OHMS P/M5% 1/4W COMPOSITION	RC07GF474J
R72	560K OHMS P/M5% 1/4W COMPOSITION	RC07GF564J
R73	560K OHMS P/M5% 1/4W COMPOSITION	RC07GF564J
R74	270 OHMS P/M5% 1/4W COMPOSITION	RC07GF271J
R75	510 OHMS P/M5% 1/4W COMPOSITION	RC07GF511J
R76	100 OHMS P/M5% 1/4W COMPOSITION	RC07GF101J
R77	100 OHMS P/M5% 1/4W COMPOSITION	RC07GF101J
R78	4.7K OHMS P/M5% 1/4W COMPOSITION	RC07GF472J
R79	33K OHMS P/M5% 1/4W COMPOSITION	RC07GF333J
R80	5.6K OHMS P/M5% 1/4W COMPOSITION	RC07GF562J
R81	2K OHMS P/M5% 1/4W COMPOSITION	RC07GF202J
R82	150 OHMS P/M5% 1/4W COMPOSITION	RC07GF151J
R83	5.1K OHMS P/M5% 1/4W COMPOSITION	RC07GF512J
R84	150K OHMS P/M5% 1/4W COMPOSITION	RC07GF154J
R85	1.5K OHMS P/M5% 1/4W COMPOSITION	RC07GF152J
R86	6.2K OHMS P/M5% 1/4W COMPOSITION	RC07GF622J
R87	2K OHMS P/M30% TRIMMER	11058-0002
R88	24K OHMS P/M5% 1/4W COMPOSITION EFFECTIVE S/N2513 AND ABOVE	RC07GF243J
R89	7.5K OHMS P/M5% 1/4W COMPOSITION EFFECTIVE S/N2513 AND ABOVE	RC07GF752J
R90	270K OHMS P/M5% 1/4W COMPOSITION EFFECTIVE S/N1200 AND ABOVE	RC07GF274J
R91	100K OHMS P/M5% 1/4W COMPOSITION	RC07GF104J
R93	100 OHMS P/M5% 1/4W COMPOSITION	RC07GF101J

Bendix Avionics Division

SECTION V.
PARTS LISTS
201F ADF RECEIVER
ELECTRICAL PARTS LIST

REF DESIG	DESCRIPTION	BENDIX PART NUMBER
R94	51 OHMS P/M5% 1/4W COMPOSITION	RC07GF510J
R95	1.1K OHMS P/M5% 1/4W COMPOSITION	RC07GF112J
R96	.6.8 OHMS P/M10% 1/2W COMPOSITION ADDED EFFECTIVE S/N2850 AND ABOVE	RC20GF6R8K
SWITCHES		
S1	WAFER	22015-0001
S2	WAFER	22015-0001
S3	WAFER	22015-0001
S4	WAFER	22015-0001
S5	WAFER	22015-0001
S6	PUSH BUTTON	22020-0003
S7	ROTARY, TYPE F	22014-0001
S8	SLIDE DPST	22013-0003
TRANSFORMERS		
T1	RF	90D042-0001
T2	RF	90D042-0001
T3	IF INTERSTAGE	90D069-0001
T4	IF INTERSTAGE	90D069-0001
T5	IF INTERSTAGE	90D069-0001
T6	IF OUTPUT	90D031-0001
T7	AUDIO	90A027-0001
T8	OUTPUT, 500 OHMS	90A026-0001
TERMINAL BOARDS		
TB1	COUNTER ASSEMBLY	4006985-0501
TB2	CLOCK OFFSET ASSEMBLY	4006983-0501
TB3	REGULATOR-DETECTOR ASSEMBLY	4006981-0501
TB4	VCO P.C. BOARD ASSEMBLY	4006990-0502
TB5	IF P.C. BOARD ASSEMBLY	TO BE SUPPLIED
TB6	TERMINAL STRIP, SUB-MINATURE	32044-0003
100-199	SYNTHESIZER ASSEMBLY	
CAPACITORS		
C101	910PF P/M2% 300VDC MICA	10206-0276
C102	4700PF P80M20% 12VDC DISC	10198-0013
C103	22UF P50M10% 16VDC ELECTROLYTIC	10227-0031
C104	22UF P50M10% 16VDC ELECTROLYTIC	10227-0031
C105	0.1UF P80M20% 12VDC DISC	10198-0015
C106	0.1UF P80M20% 12VDC DISC	10198-0015
C107	0.1UF P80M20% 12VDC DISC	10198-0015
C108	20PF P/M2% 500VDC MICA	10205-0207
C109	22UF P50M10% 16VDC ELECTROLYTIC	10227-0031
C110	120PF P/M10% 500VDC MICA	10205-0510
C111	1.0UF P/M10% 15VDC TANTALUM	10124-1310
C112	0.1UF P80M20% 12VDC DISC DELETED EFF. S/N1166 AND ABOVE	10198-0015
C112	0.022UF P80/M20% 30VDC DISC EFFECTIVE S/N1532 AND ABOVE	10198-0023
C113	0.1UF P80M20% 12VDC DISC	10198-0015
C116	22UF P50M10% 16VDC ELECTROLYTIC	10227-0031
C117	22UF P50M10% 16VDC ELECTROLYTIC	10227-0031

Bendix Avionics Division

SECTION V.
PARTS LISTS
 201F ADF RECEIVER
 ELECTRICAL PARTS LIST

REF DESIG	DESCRIPTION	BENDIX PART NUMBER
C119	0.1UF P/M20% 50VDC MYLAR EFFECTIVE S/N1166 AND ABOVE	2068209-0719
C121	22UF P50M10% 16VDC ELECTROLYTIC	10227-0031
C122	0.1UF P80M20% 12VDC DISC	10198-0015
C123	0.1UF P80M20% 12VDC DISC	10198-0015
C124	390PF P/M10% 100VDC MICA	10205-0529
C131	0.1UF P80M20% 12VDC DISC	10198-0015
C131	0.022UF P80/M20% 30VDC DISC EFFECTIVE S/N1532 AND ABOVE	10198-0023
DIODES		
CR101	1N914 SILICON	12013-0001
CR112	1N914 SILICON DELETED EFF. S/N1166 AND ABOVE	12013-0001
CR114	1N959B ZENER	12043-0083
CR114	1N4370 EFFECTIVE S/N1601 AND ABOVE	12043-0024
CR115	1N746A ZENER	12043-0035
CR116	1N751A ZENER	12043-0060
CR117	1N755A ZENER EFFECTIVE S/N3096-3099,3102,3116,3118 AND ABOVE	12043-0066
INDUCTORS		
L101	8.20MH P/M10% FIXED	17018-0016
L102	220UH P/M10% MOLDED EFFECTIVE S/N1166 AND ABOVE	17019-0041
TRANSISTORS		
Q101	SPS-938 NPN SILICON	12047-0072
Q102	SPS-938 NPN SILICON	12047-0072
Q104	SPS-938 NPN SILICON	12047-0072
Q105	SPS-938 NPN SILICON	12047-0072
Q106	SPS-938 NPN SILICON	12047-0072
Q107	SPS-938 NPN SILICON	12047-0072
Q111	SPS-938 NPN SILICON	12047-0072
Q112	2N2270 NPN SILICON	12047-0041
Q115	TIP-29 NPN SILICON	12044-0034
Q116	SPS-938 NPN SILICON	12047-0072
Q117	SPS-938 NPN SILICON	12047-0072
RESISTORS		
R101	470K OHMS P/M5% 1/4W COMPOSITION	RC07GF474J
R101	1MEG OHMS P/M5% 1/4W COMPOSITION EFFECTIVE S/N1166 AND ABOVE	RC07GF105J
R102	120K OHMS P/M5% 1/4W COMPOSITION	RC07GF124J
R102	240K OHMS P/M5% 1/4W COMPOSITION EFFECTIVE S/N1166 AND ABOVE	RC07GF244J
R103	3.9K OHMS P/M5% 1/4W COMPOSITION	RC07GF392J
R104	2.2K OHMS P/M5% 1/4W COMPOSITION	RC07GF222J
R105	680 OHMS P/M5% 1/4W COMPOSITION	RC07GF681J

Bendix Avionics Division

SECTION V.

PARTS LISTS

201F ADF RECEIVER
ELECTRICAL PARTS LIST

REF DESIG	DESCRIPTION	BENDIX PART NUMBER
R106	18K OHMS P/M5% 1/4W COMPOSITION	RC07GF183J
R107	150K OHMS P/M5% 1/4W COMPOSITION	RC07GF154J
R108	3.3K OHMS P/M5% 1/4W COMPOSITION	RC07GF332J
R111	1K OHMS P/M5% 1/4W COMPOSITION	RC07GF102J
R112	10 OHMS P/M5% 1/4W COMPOSITION	RC07GF100J
R114	3K OHMS P/M5% 1/4W COMPOSITION	RC07GF302J
R115	56K OHMS P/M5% 1/4W COMPOSITION	RC07GF563J
R116	1K OHMS P/M5% 1/4W COMPOSITION	RC07GF102J
R117	2.2K OHMS P/M5% 1/4W COMPOSITION	RC07GF222J
R121	2.2K OHMS P/M5% 1/4W COMPOSITION	RC07GF222J
R122	8.2K OHMS P/M5% 1/4W COMPOSITION	RC07GF822J
R123	1K OHMS P/M5% 1/4W COMPOSITION	RC07GF102J
R124	10K OHMS P/M5% 1/4W COMPOSITION	RC07GF103J
R124	6200 OHMS P/M5% 1/4W COMPOSITION EFFECTIVE S/N1601 AND ABOVE	RC07GF622J
R125	75K OHMS P/M5% 1/4W COMPOSITION	RC07GF753J
R125	51K OHMS P/M5% 1/4W COMPOSITION EFFECTIVE S/N1601 AND ABOVE	RC07GF513J
R126	2K OHMS NOM. SELECTED VALUE	RC07GF202J
R126	1.3K OHMS P/M5% 1/4W COMPOSITION EFFECTIVE S/N1601 AND ABOVE	RC07GF132J
R127	20K OHMS P/M5% 1/4W COMPOSITION	RC07GF203J
R128	1.2K OHMS P/M5% 1/4W COMPOSITION EFFECTIVE S/N1166 AND ABOVE	RC07GF122J
R128	3K OHMS P/M5% 1/4W COMPOSITION EFFECTIVE S/N1601 AND ABOVE	RC07GF302J
R131	4.3K OHMS P/M5% 1/4W COMPOSITION	RC07GF432J
R131	1.8K OHMS P/M5% 1/4W COMPOSITION EFFECTIVE S/N1601 AND ABOVE	RC07GF182J
R132	1.1K OHMS P/M5% 1/4W COMPOSITION	RC07GF112J
R133	130 OHMS P/M5% 1/4W COMPOSITION	RC07GF131J
R134	4.3K OHMS P/M5% 1/4W COMPOSITION	RC07GF432J
R134	47K OHMS P/M5% 1/4W COMPOSITION EFFECTIVE S/N1601 AND ABOVE	RC07GF473J
R135	47K OHMS P/M5% 1/4W COMPOSITION DELETED EFF. S/N1166 AND ABOVE	RC07GF473J
R141	10K OHMS P/M5% 1/4W COMPOSITION	RC07GF103J
R142	2.7K OHMS P/M5% 1/4W COMPOSITION	RC07GF272J
R143	12K OHMS P/M5% 1/4W COMPOSITION	RC07GF123J
R144	2.2K OHMS P/M5% 1/4W COMPOSITION	RC07GF222J
R145	2.2K OHMS P/M5% 1/4W COMPOSITION	RC07GF222J
R146	1K OHMS P/M5% 1/4W COMPOSITION	RC07GF102J
R147	91 OHMS P/M5% 1/4W COMPOSITION	RC07GF910J
R151	390 OHMS P/M5% 1/4W COMPOSITION	RC07GF391J
R152	200 OHMS P/M5% 1/4W COMPOSITION	RC07GF201J
R156	22 OHMS P/M5% 1/4W COMPOSITION	RC07GF220J
R156	47 OHMS P/M5% 1/4W COMPOSITION EFFECTIVE S/N1601 AND ABOVE	RC07GF470J
R157	2K OHMS P/M30% TRIMMER	11058-0002
R160	100 OHMS P/M5% 1/4W COMPOSITION	RC07GF101J
R160	270 OHMS P/M5% 1/4W COMPOSITION EFFECTIVE S/N1601 AND ABOVE	RC07GF271J
R160	180 OHMS P/M5% 1/4W COMPOSITION EFFECTIVE S/N3086 AND ABOVE	RC07GF181J
R161	2.2K OHMS P/M5% 1/4W COMPOSITION EFFECTIVE S/N1166 AND ABOVE	RC07GF222J

Bendix Avionics Division

I. B. 2012B

SECTION V.
PARTS LISTS
 201F ADF RECEIVER
 ELECTRICAL PARTS LIST

REF DESIG	DESCRIPTION	BENDIX PART NUMBER
R162	2.2K OHMS P/M5% 1/4W COMPOSITION EFFECTIVE S/N1166 AND ABOVE	RC07GF222J
R163	2.2K OHMS P/M5% 1/4W COMPOSITION EFFECTIVE S/N1166 AND ABOVE	RC07GF222J
R164	2.2K OHMS P/M5% 1/4W COMPOSITION EFFECTIVE S/N1166 AND ABOVE	RC07GF222J
R165	2.2K OHMS P/M5% 1/4W COMPOSITION EFFECTIVE S/N1166 AND ABOVE	RC07GF222J
R166	2.2K OHMS P/M5% 1/4W COMPOSITION EFFECTIVE S/N1166 AND ABOVE	RC07GF222J
R167	2.2K OHMS P/M5% 1/4W COMPOSITION EFFECTIVE S/N1166 AND ABOVE	RC07GF222J
R168	2.2K OHMS P/M5% 1/4W COMPOSITION EFFECTIVE S/N1166 AND ABOVE	RC07GF222J
R171	3.3K OHMS P/M5% 1/4W COMPOSITION EFFECTIVE S/N1166 AND ABOVE	RC07GF332J

THERMISTORS

RT102	10K OHMS @37.8DEG C	2088175-0020
-------	---------------------	--------------

INTEGRATED CIRCUITS

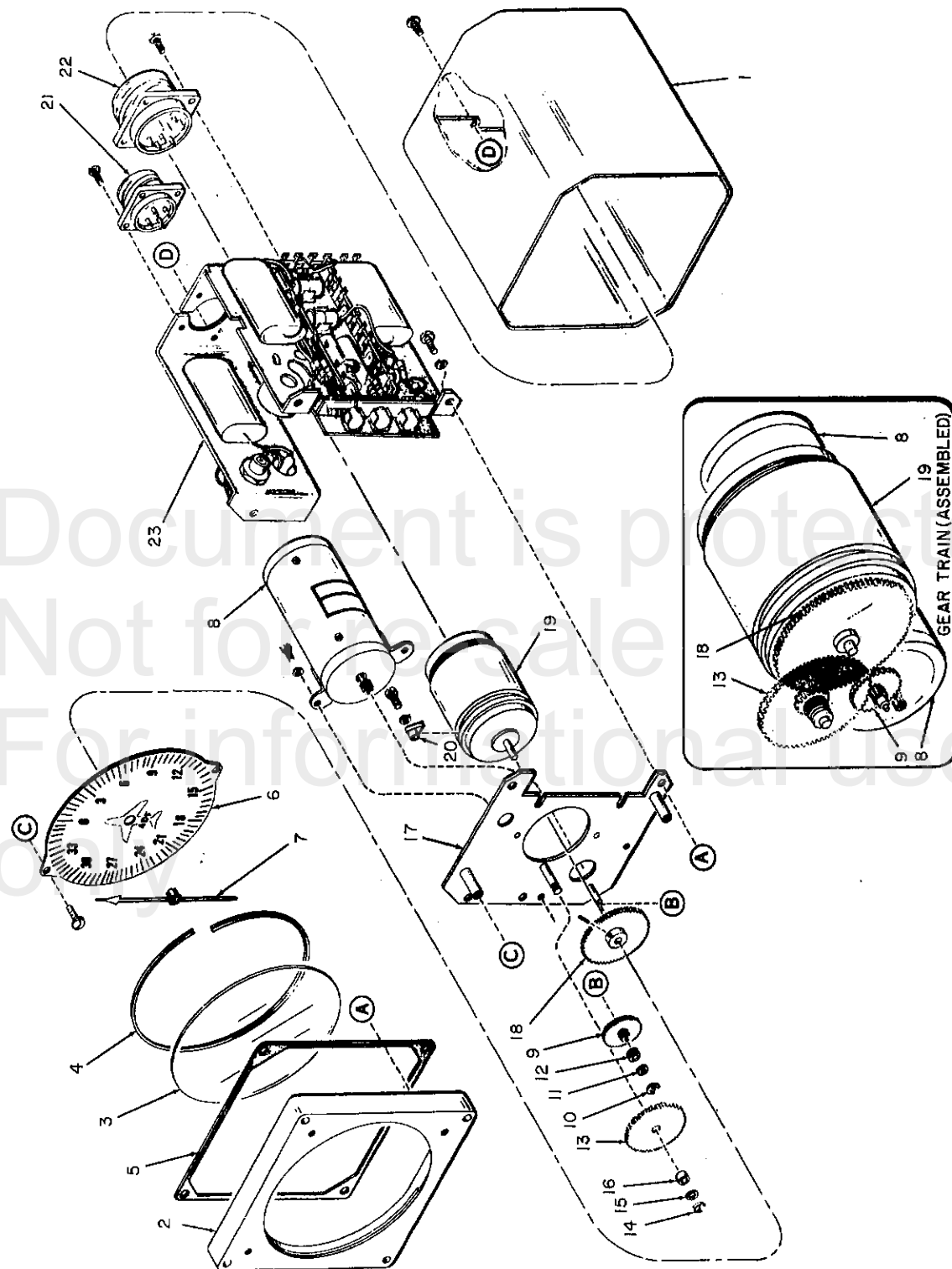
U101	DUAL-IN-LINE 4-BIT BINARY COUNTER	51007-0061
U102	DUAL-IN-LINE 4-BIT BINARY COUNTER	51007-0061
U103	DUAL-IN-LINE PROGRAMMABLE MODULO-N DECADE COUNTER	51007-0062
U104	DUAL-IN-LINE PROGRAMMABLE MODULO-N DECADE COUNTER	51007-0062
U105	DUAL-IN-LINE PROGRAMMABLE MODULO-N DECADE COUNTER	51007-0062
U106	DUAL-IN-LINE DUAL D-TYPE EDGE-TRIGGERED FLIP-FLOP	51007-0060
U107	DUAL-IN-LINE TRIPLE 3-INPUT NAND GATE	51007-0050
U111	DUAL-IN-LINE QUAD 2-INPUT NAND GATE/OPEN-COLL OUTPUT	51007-0058
U112	DUAL-IN-LINE QUAD 2-INPUT NAND GATE	51007-0057
U113	DUAL-IN-LINE DUAL 2-WIDE 2-INPUT AND-OR-INVERT GATE	51007-0059
U114	DUAL-IN-LINE DUAL 2-WIDE 2-INPUT AND-OR-INVERT GATE	51007-0059
U115	PHASE FREQUENCY DETECTOR	51013-0001

CRYSTALS

Y101	QUARTZ 256.00KHZ P/M.02%	13013-0023
------	--------------------------	------------

Bendix Avionics Division

SECTION V.
PARTS LISTS



551A Servo Amplifier-Indicator, Exploded View
Figure 5-3

Bendix Avionics Division

SECTION V.

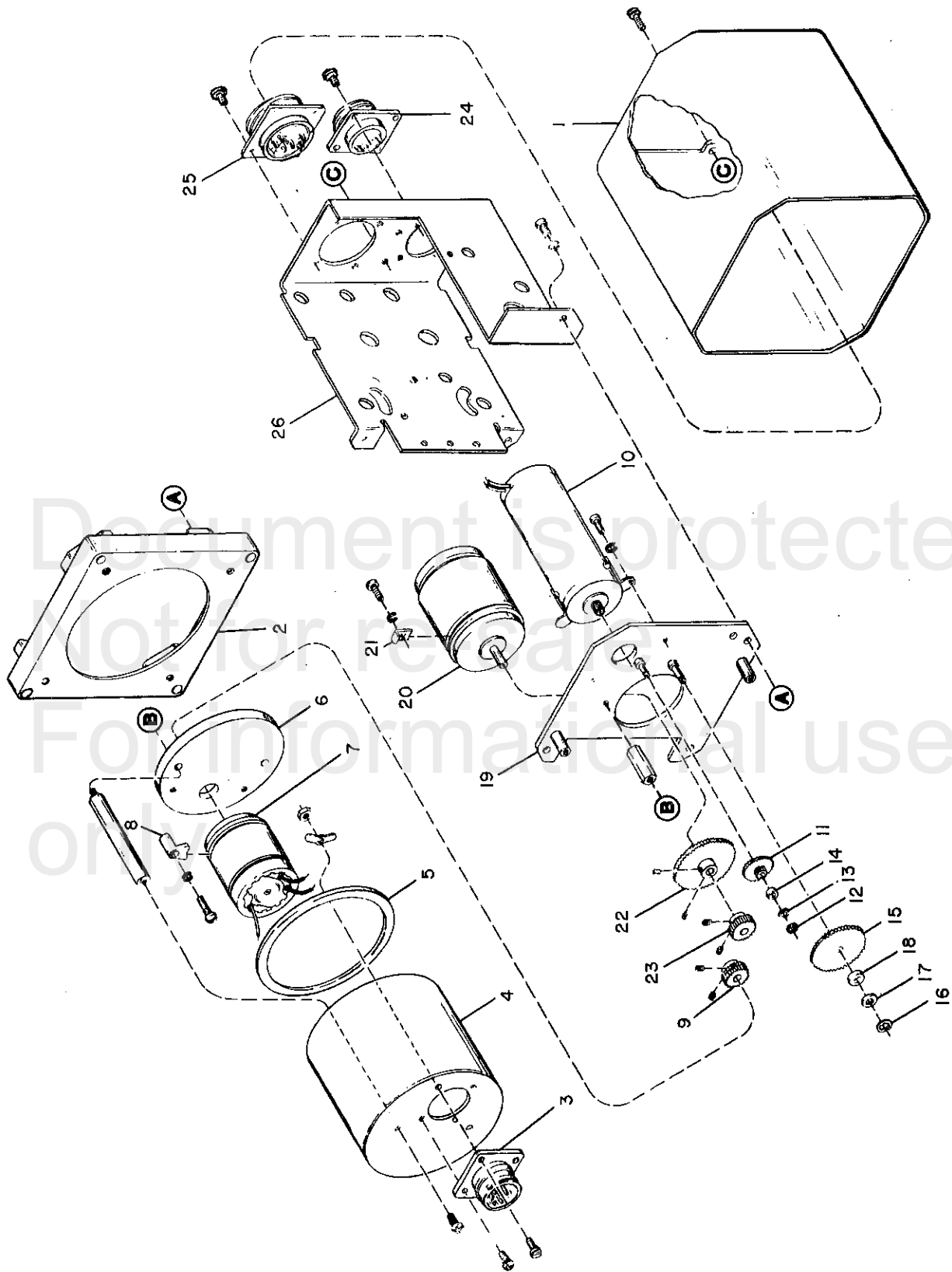
PARTS LISTS

551A SERVO AMPLIFIER - INDICATOR
MECHANICAL PARTS LIST

REF DESIG	FIG ITEM	DESCRIPTION	BENDIX PART NUMBER
	5-3	SERVO AMPLIFIER INDICATOR, MODEL 551A	1U027-01
	1	COVER, INDICATOR BEZEL ASSEMBLY	60B031-0001 4006709-0501
	2	.BEZEL, INDICATOR	70C019-0001
	3	.GLASS, DISC	49002-0002
	4	.RING, GLASS RETAINING	62B037-0002
	5	GASKET, FRAME GEAR TRAIN AND DIAL ASSEMBLY	81C014-0001 1V027-97-1
	6	.DIAL, GONIOMETER	63C062-0001
	7	.POINTER ASSEMBLY .MOTOR AND GEAR TRAIN ASSEMBLY .MOTOR AND GEAR TRAIN ASSEMBLY EFFECTIVE S/N28227 AND ABOVE	63B064-0001 86C009-0001 4007177-0501
B1	8	..MOTOR ...END CAP ASSEMBLY, FRONT -P/O ITEM 8- ...END CAP ASSEMBLY, REAR -P/O ITEM 8-	86C009-0501 86C009-0509 86C009-0510
B1	8A	..MOTOR ASSEMBLY EFFECTIVE S/N28127 AND ABOVE ...MOTOR -P/O ITEM 8A- ...END CAP ASSEMBLY, REAR -P/O MOTOR- ...P.C.BOARD ASSEMBLY -P/O ITEM 8A-	4004554-0501 4004554-0001 4004554-0002 4007098-0001
	9	..GEAR, SPUR REDUCTION	86C009-0503
	9	..GEAR, SPUR REDUCTION EFFECTIVE S/N28227 AND ABOVE	4004542-0001
	10	..RING, RETAINING	36001-0003
	10	..RING, RETAINING EFFECTIVE S/N28227 AND ABOVE	36001-003C
	11	..WASHER, BRASS	86C009-0508
	11	..WASHER, BRASS EFFECTIVE S/N28227 AND ABOVE	36017-0023
	12	..WASHER, FELT	86C009-0506
	12	..WASHER, FELT EFFECTIVE S/N28227 AND ABOVE	36016-0009
	13	..GEAR, SPUR REDUCTION	86C009-0502
	13	..GEAR, SPUR REDUCTION EFFECTIVE S/N28227 AND ABOVE	4004543-0001
	14	..RING, RETAINING	36001-0006
	14	..RING, RETAINING EFFECTIVE S/N28227 AND ABOVE	36001-006C
	15	..WASHER, BRASS	86C009-0507
	15	..WASHER, BRASS EFFECTIVE S/N28227 AND ABOVE	36017-0024
	16	..WASHER, FELT	86C009-0505
	16	..WASHER, FELT EFFECTIVE S/N28227 AND ABOVE	36016-0009
	17	..PLATE, GEAR	86C009-0504
	17	..PLATE, GEAR EFFECTIVE S/N28227 AND ABOVE	4006997-0501
	18	.GEAR, RESOLVER	86C009-0500
	18	.GEAR, RESOLVER EFFECTIVE S/N28227 AND ABOVE	4004545-0001
B2	19	.RESOLVER, GONIOMETER	1V023-01
	20	.CLAMP, SYNCHRO MOUNTING -2 EA-	62C109-0004
J2	21	.CONNECTOR WK-4-32S	24062-0010
J1	22	CONNECTOR GK-9-32S	24062-0001
	23	WIRED CHASSIS ASSEMBLY -INCLUDES COMPONENTS- GASKET, REAR -NOT ILLUSTRATED- SHIELD -NOT ILLUSTRATED-	1V027-98-1 81B021-0001 63B164-0001

Bendix Avionics Division

SECTION V.
PARTS LISTS



551B Remote Servo Amplifier, Exploded View

Figure 5-4

Bendix Avionics Division

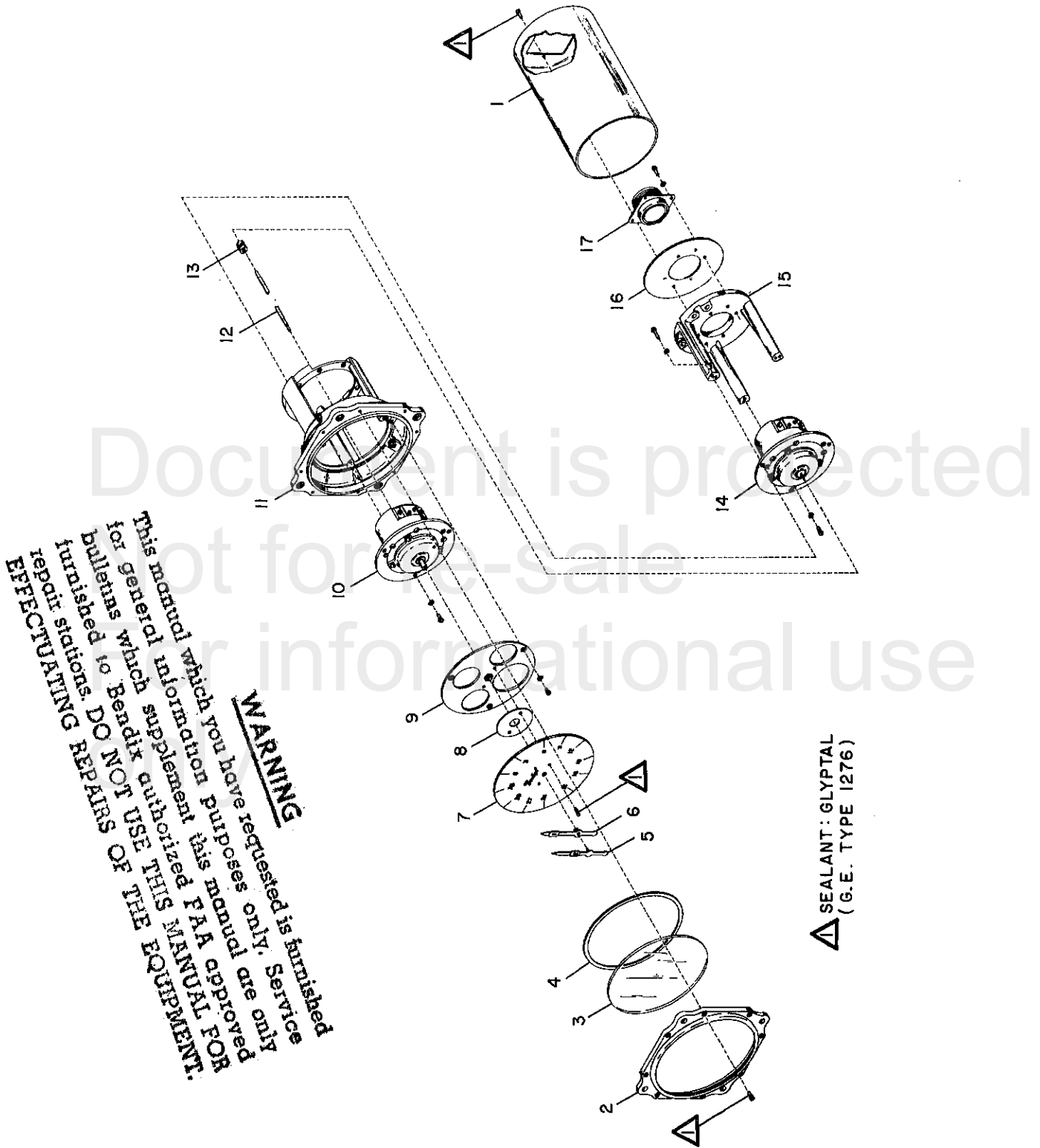
**SECTION V.
PARTS LISTS**

**551B REMOTE GONIO SYNCHRO
MECHANICAL PARTS LIST**

REF DESIG	FIG ITEM	DESCRIPTION	BENDIX PART NUMBER
	5-4	REMOTE GONIO SYNCHRO, MODEL 551B	1U027-02
	1	COVER, INDICATOR	608031-0001
	2	BEZEL	70C019-0001
J3	3	CONNECTOR	24062-0004
	4	COVER, SYNCHRO	608049-0001
	5	GASKET, SYNCHRO COVER SYNCHRO PLATE ASSEMBLY	818055-0001 4006715-0501
	6	.PLATE, SYNCHRO MOUNTING -2 EA-	67B033-0001
B3	7	.SYNCHRO, TRANSMITTER	220908-0002
	8	.CLAMP, SYNCHRO MOUNTING	33006-0005
	9	GEAR ASSEMBLY, ANTI-BACKLASH GEAR TRAIN AND GONIO ASSEMBLY .MOTOR AND GEAR TRAIN ASSEMBLY	1V027-95-1 1V026-96-1 86C009-0001
B1	10	..MOTOR	86C009-0501
		...END CAP ASSEMBLY, FRONT -P/O ITEM 10-	86C009-0509
		...END CAP ASSEMBLY, REAR -P/O ITEM 10-	86C009-0510
	11	..GEAR, SPUR REDUCTION	86C009-0503
	12	..RING, RETAINING	36001-0003
	13	..WASHER, BRASS	86C009-0508
	14	..WASHER, FELT	86C009-0506
	15	..GEAR, SPUR REDUCTION	86C009-0502
	16	..RING, RETAINING	36001-0006
	17	..WASHER, BRASS	86C009-0507
	18	..WASHER, FELT	86C009-0505
	19	..PLATE, GEAR	86C009-0504
B2	20	.RESOLVER, GONIOMETER	1V023-01
	21	.CLAMP, SYNCHRO MOUNTING -2 EA-	62C109-0004
	22	.GEAR, RESOLVER	86C009-0500
	23	.GEAR, RESOLVER	68B055-0001
J2	24	.CONNECTOR WK-4-32S	24062-0010
	25	CONNECTOR GK-9-32S	24062-0001
	26	WIRED CHASSIS ASSEMBLY -INCLUDES COMPONENTS- GASKET, REAR -NOT ILLUSTRATED- GASKET, FRAME -NOT ILLUSTRATED- SHIELD -NOT ILLUSTRATED-	1V027-98-1 81B021-0001 81C014-0001 63B164-0001

Bendix Avionics Division

SECTION V.
PARTS LISTS



551C Dual Synchro Indicator, Exploded View
Figure 5-5

Bendix Avionics Division

SECTION V.
PARTS LISTS

551C DUAL SYNCHRO INDICATOR
MECHANICAL PARTS LIST

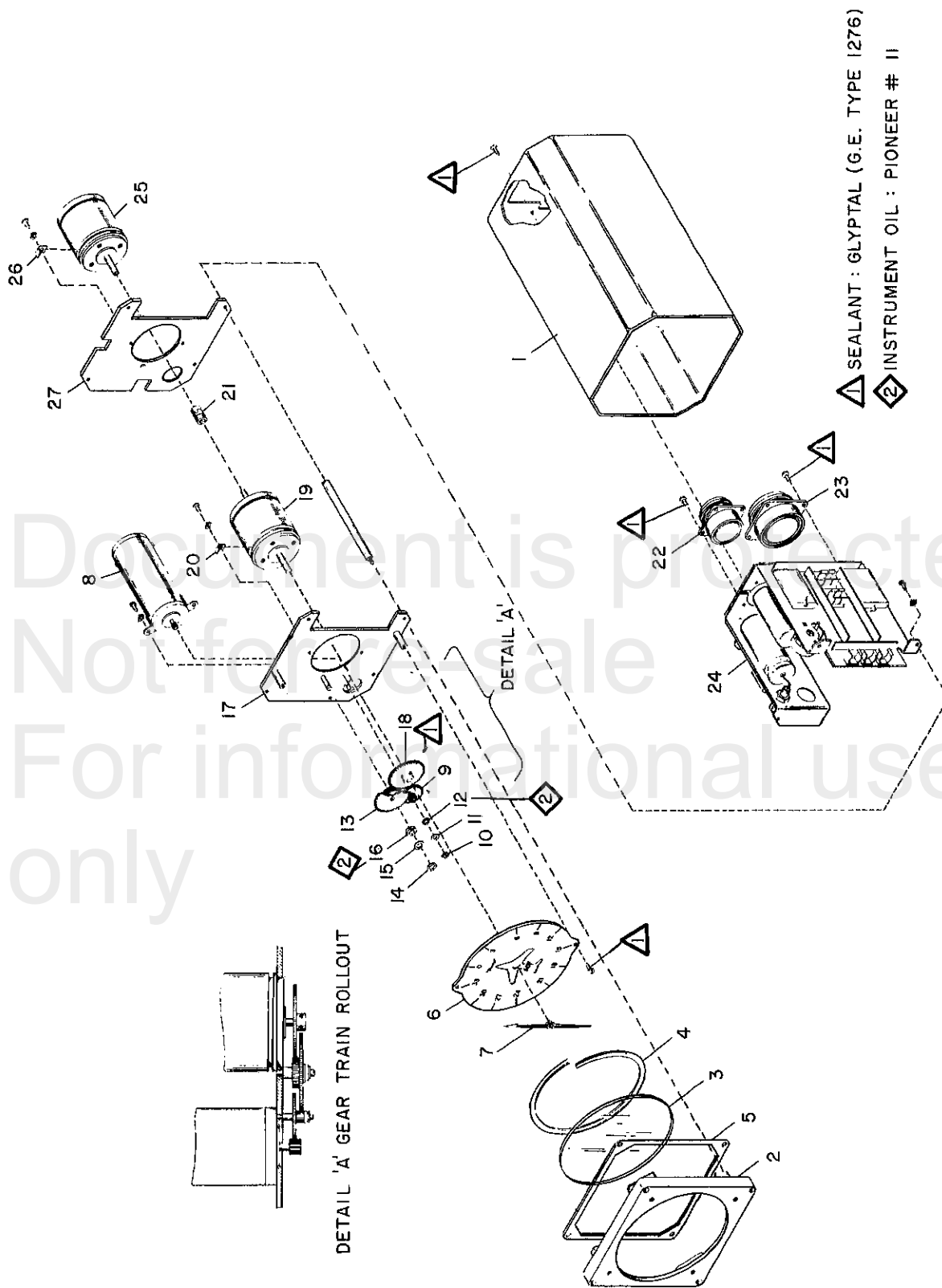
REF DESIG	FIG ITEM	DESCRIPTION	BENDIX PART NUMBER
--------------	-------------	-------------	-----------------------

5-5		DUAL SYNCHRO INDICATOR MODEL 551C	1U63938
	1	COVER	701056-0002
	2	BEZEL	716830-0001
	3	GLASS	716831-0001
	4	GASKET	716832-0001
	5	POINTER,NO.2 WHITE TIP	96919-0002
		POINTER,NO.2 GREEN TIP	96919-0004
	6	POINTER,NO.1 WHITE TIP	96919-0001
		POINTER,NO.1 GREEN TIP	96919-0003
	7	DIAL,WHITE MARKINGS	96729-0001
		DIAL,GREEN MARKINGS	96729-0002
	8	SPACER	716833-0001
	9	FILLER	716834-0001
	10	SYNCHRO ASSEMBLY	1V701057-02
	11	HOUSING	716835-0001
	12	SHAFT	716836-0001
	13	HUB,COUPLING	68A067-0001
	14	SYNCHRO ASSEMBLY	1V701057-02
	15	FRAME	716837-0001
	16	SEAL,FELT	716838-0001
	17	CONNECTOR	716839-0001

Document is protected
Not for re-sale
For informational use
only

Bendix Avionics Division

**SECTION V.
PARTS LISTS**



▲ SEALANT : GLYPTAL (G.E. TYPE 1276)
 ◆ INSTRUMENT OIL : PIONEER # 11

551E Servo Amplifier-Indicator, Exploded View
 Figure 5-6

Bendix Avionics Division

**SECTION V.
PARTS LISTS**

**551E SERVO AMPLIFIER - INDICATOR
MECHANICAL PARTS LIST**

REF DESIG	FIG ITEM	DESCRIPTION	BENDIX PART NUMBER
	5-6	SERVO AMPLIFIER INDICATOR, MODEL 551E WITH MATING CONNECTOR 24061-0019 WITHOUT MATING CONNECTOR	1U027-05 1U027-04
	1	COVER, INDICATOR BEZEL ASSEMBLY	608031-0002 4006709-0501
	2	.BEZEL, INDICATOR	70C019-0001
	3	.GLASS, DISC	49002-0002
	4	.RING, GLASS RETAINING	62B037-0002
	5	GASKET, FRAME	81C014-0001
		GEAR TRAIN AND DIAL ASSEMBLY	1V027-97-3
	6	.DIAL, GONIOMETER	63C062-0001
	7	.POINTER ASSEMBLY .MOTOR AND GEAR TRAIN ASSEMBLY .MOTOR AND GEAR TRAIN ASSEMBLY	63B064-0001 86C009-0001 4007177-0501
		EFFECTIVE S/N3791 AND ABOVE	
B1	8	..MOTOR	86C009-0501
		...END CAP ASSEMBLY, FRONT -P/O ITEM 8-	86C009-0509
		...END CAP ASSEMBLY, REAR -P/O ITEM 8-	86C009-0510
B1	8A	..MOTOR ASSEMBLY	4004554-0501
		EFFECTIVE S/N3741 AND ABOVE	
		...MOTOR -P/O ITEM 8A-	4004554-0001
		...END CAP ASSEMBLY, REAR -P/O MOTOR-	4004554-0002
		...P.C. BOARD ASSEMBLY -P/O ITEM 8A-	4007098-0001
	9	..GEAR, SPUR REDUCTION	86C009-0503
	9	..GEAR, SPUR REDUCTION	4004542-0001
		EFFECTIVE S/N3791 AND ABOVE	
	10	..RING, RETAINING	36001-0003
	10	..RING, RETAINING	36001-003C
		EFFECTIVE S/N3791 AND ABOVE	
	11	..WASHER, BRASS	86C009-0508
	11	..WASHER, BRASS	36017-0023
		EFFECTIVE S/N3791 AND ABOVE	
	12	..WASHER, FELT	86C009-0506
	12	..WASHER, FELT	36016-0009
		EFFECTIVE S/N3791 AND ABOVE	
	13	..GEAR, SPUR REDUCTION	86C009-0502
	13	..GEAR, SPUR REDUCTION	4004543-0001
		EFFECTIVE S/N3791 AND ABOVE	
	14	..RING, RETAINING	36001-0006
	14	..RING, RETAINING	36001-006C
		EFFECTIVE S/N3791 AND ABOVE	
	15	..WASHER, BRASS	86C009-0507
	15	..WASHER, BRASS	36017-0024
		EFFECTIVE S/N3791 AND ABOVE	
	16	..WASHER, FELT	86C009-0505
	16	..WASHER, FELT	36016-0009
		EFFECTIVE S/N3791 AND ABOVE	
	17	..PLATE, GEAR	86C009-0504
	17	..PLATE, GEAR	4006997-0501
		EFFECTIVE S/N3791 AND ABOVE	
	18	.GEAR, RESOLVER	86C009-0500
	18	.GEAR, RESOLVER	4004545-0001
		EFFECTIVE S/N3791 AND ABOVE	
B2	19	.RESOLVER, GONIOMETER	1V023-03
	20	.CLAMP, SYNCHRO MOUNTING -2 EA-	62C109-0004
	21	COUPLING, FLEXIBLE	38001-0005
J2	22	.CONNECTOR WK-4-32S	24062-0001

Bendix Avionics Division

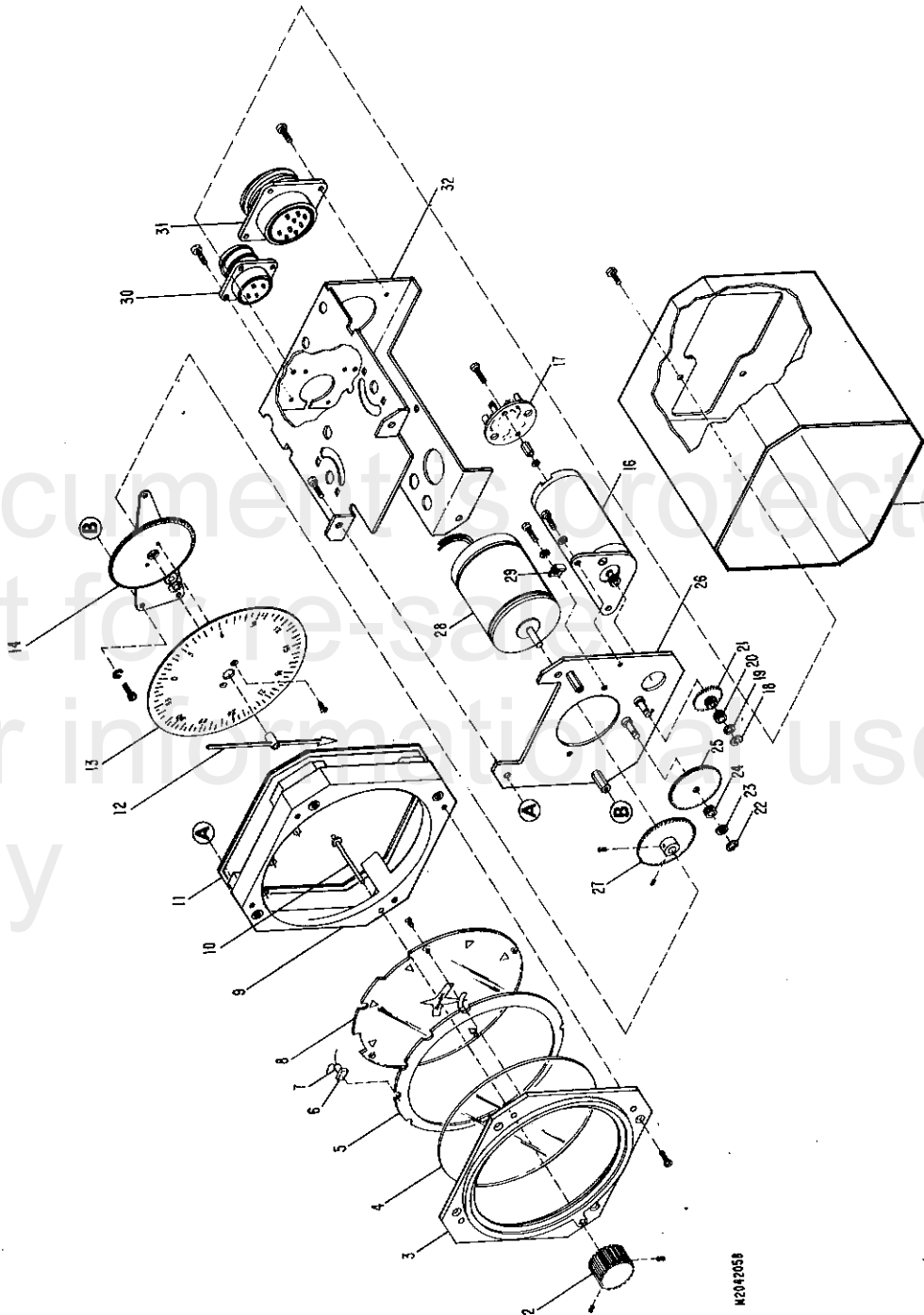
SECTION V.
PARTS LISTS
551E SERVO AMPLIFIER - INDICATOR
MECHANICAL PARTS LIST

REF DESIG	FIG ITEM	DESCRIPTION	BENDIX PART NUMBER
J1	23	CONNECTOR GK-12-32S	24062-0012
	24	WIRED CHASSIS ASSEMBLY -INCLUDES COMPONENTS- SYNCHRO PLATE ASSEMBLY	1V027-98-2 4006712-0501
	25	.SYNCHRO, TRANSMITTER	220908-2
	26	.CLAMP, SYNCHRO MOUNTING -2 EA-	62C109-0004
	27	.PLATE, GEAR	4002418-0001
		GASKET, REAR -NOT ILLUSTRATED-	818021-0001

Document is protected
Not for re-sale
For informational use
only

SECTION V.
PARTS LISTS

551RL SERVO AMPLIFIER-INDICATOR
MECHANICAL PARTS LIST



551RL Servo Amplifier-Indicator, Exploded View
Figure 5-6a

SECTION V.
PARTS LISTS
SERVO AMPLIFIER - INDICATOR
MECHANICAL PARTS LIST

REF DESIG	FIG ITEM	DESCRIPTION	BENDIX PART NUMBER
	5-6A	SERVO AMP INDICATOR, MODEL 551RL	4000240-5101
	1	COVER, INDICATOR	608031-0001
	2	KNOB	4002419-0503
	3	MASK, BEZEL	4003284-0001
	4	LENS	4003285-0001
	5	RING, CONTACT	4003282-0001
	6	FILTER, LAMP	21024-0008
DS1-DS 2	7	LAMP, INDICATOR	21023-0701
	8	PLATE, INDICE	4006654-0502
	9	BEZEL, INDICATOR -MOLDED ASSEMBLY- RETAINING MASK ASSEMBLY	4003279-0501
	10	GEAR, PINION AND KNOB SHAFT	4006653-0501
	11	GASKET, FRAME	688062-0001
		GEAR TRAIN AND DIAL ASSEMBLY	4003276-0001
	12	POINTER ASSEMBLY	1V027-97-2
	13	DIAL, ROTATABLE	638064-0002
	14	PLATE, GEAR ASSEMBLY	4003278-0001
		MOTOR AND GEAR TRAIN ASSEMBLY	87C006-0501
		MOTOR AND GEAR TRAIN ASSEMBLY	86C009-0002
		EFFECTIVE S/N2724 AND ABOVE	4007177-0501
B1	15	MOTOR	86C009-0501
		END CAP ASSEMBLY, FRONT -P/O ITEM 15	86C009-0509
		END CAP ASSEMBLY, REAR -P/O ITEM 15	86C009-0510
	15A	MOTOR ASSEMBLY	4004554-0501
		EFFECTIVE S/N2674 AND ABOVE	
	16	MOTOR -P/O ITEM 15A-	4004554-0001
		EFFECTIVE S/N2674 AND ABOVE	
		END CAP ASSEMBLY, REAR -P/O ITEM 15A-	4004554-0002
	17	BOARD ASSEMBLY -P/O ITEM 15A-	4007098-0501
		EFFECTIVE S/N2674 AND ABOVE	
	18	RING, RETAINING	36001-0003
	18	RING, RETAINING	36001-003C
		EFFECTIVE S/N2724 AND ABOVE	
	19	WASHER, BRASS	86C009-0508
	19	WASHER, BRASS	36017-0023
		EFFECTIVE S/N2724 AND ABOVE	
	20	WASHER, FELT	86C009-0506
	20	WASHER, FELT	36016-0009
		EFFECTIVE S/N2724 AND ABOVE	
	21	GEAR, SPUR REDUCTION	86C009-0503
	21	GEAR, SPUR REDUCTION	4004542-0001
		EFFECTIVE S/N2724 AND ABOVE	
	22	RING, RETAINING	36001-0006
	22	RING, RETAINING	36001-006C
		EFFECTIVE S/N2724 AND ABOVE	
	23	WASHER, BRASS	86C009-0507
	23	WASHER, BRASS	36017-0024
		EFFECTIVE S/N2724 AND ABOVE	
	24	WASHER, FELT	86C009-0505
	24	WASHER, FELT	36016-0019
		EFFECTIVE S/N2724 AND ABOVE	
	25	GEAR, SPUR REDUCTION	86C009-0502
	25	GEAR, SPUR REDUCTION	4004543-0001
		EFFECTIVE S/N2724 AND ABOVE	
	26	PLATE, GEAR	86C009-0504
	26	PLATE, GEAR	4006997-0501
		EFFECTIVE S/N2724 AND ABOVE	

Bendix Avionics Division

SECTION V.
PARTS LISTS
SERVO AMPLIFIER - INDICATOR
MECHANICAL PARTS LIST

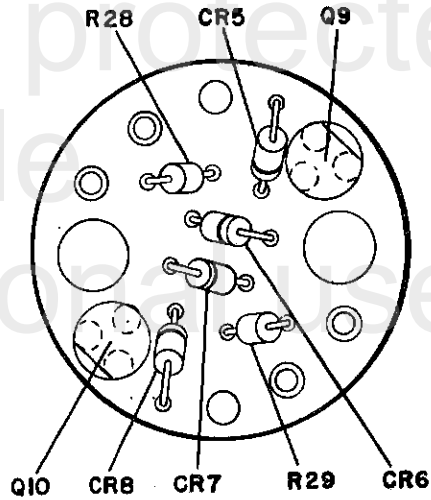
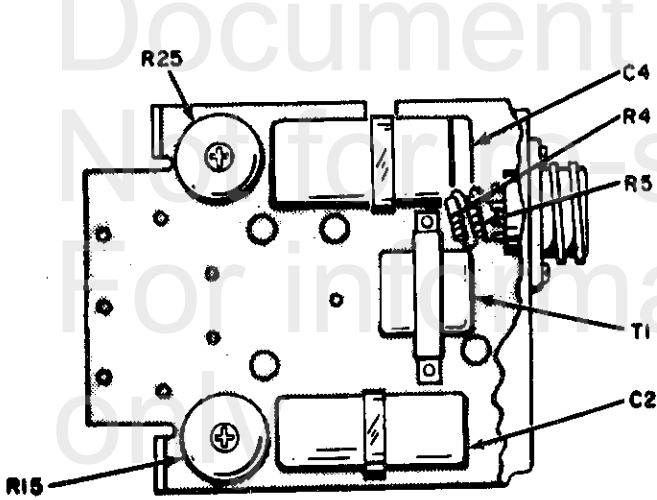
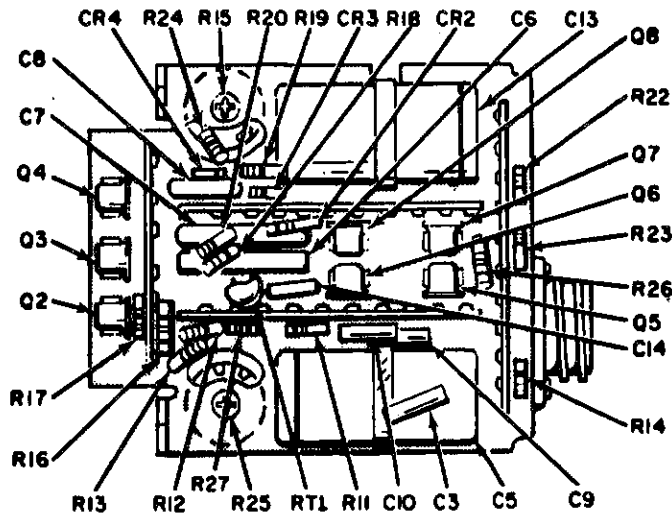
REF DESIG	FIG ITEM	DESCRIPTION	BENDIX PART NUMBER
	27	GEAR, RESOLVER	86C009-0500
	27	GEAR, RESOLVER .EFFECTIVE S/N2724 AND ABOVE	4004545-0001
B2	28	RESOLVER, GONIOMETER	1V023-01
	29	CLAMP, SYNCHRO MOUNTING	62C109-0004
J2	30	CONNECTOR WK-4-32S	24062-0010
J1	31	CONNECTOR GK-9-32S	24062-0001
	32	WIRED CHASSIS ASSEMBLY -INCLUDES COMPONENTS- GASKET, REAR SHIELD	1V027-98-3 818021-0001 638164-0001

Document is protected
Not for re-sale
For informational use
only

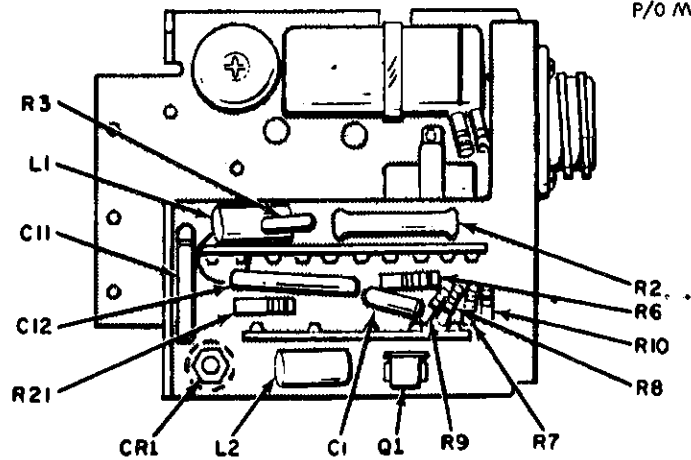
Bendix Avionics Division

SECTION V.
PARTS LISTS

SERVO AMPLIFIER-INDICATOR



(PC BOARD P/N 400709B-0001
P/O MOTOR ASSEMBLY)



Servo Amplifier-Indicators Electrical
Components, Layout Diagram
Figure 5-7

SECTION V.
PARTS LISTS
SERVO AMPLIFIER-INDICATOR CHASSIS
ELECTRICAL PARTS LIST

REF DESIG	DESCRIPTION	BENDIX PART NUMBER
MOTORS/ROTATING COMPONENTS		
B1	MOTOR (REF.)	
B2	GONIOMETER	1V023-01
B3	SYNCHRO TRANSMITTER (551B AND 551E ONLY)	220908-0002
CAPACITORS		
C1	39UF P/M20% 10VDC TANTALUM	10098-0002
C2	1000UF P/M20% 10VDC ELECTROLYTIC	10049-0003
C3	39UF P/M20% 10VDC TANTALUM	10098-0002
C4	1.0UF P/M10% 200VDC MYLAR	10171-0007
C5	1.0UF P/M10% 200VDC MYLAR	10171-0007
C6	0.1UF P/M20% 200VDC MYLAR	10092-0004
C7	0.1UF P/M20% 200VDC MYLAR	10092-0004
C8	39UF P/M20% 10VDC TANTALUM	10098-0002
C9	39UF P/M20% 10VDC TANTALUM	10098-0002
C10	39UF P/M20% 10VDC TANTALUM	10098-0002
C11	0.068UF P/M20% 200VDC MYLAR	10171-0008
C12	0.068UF P/M20% 200VDC MYLAR	10171-0008
C13	1.5UF P/M20% 200VDC MYLAR	10171-0009
C14	39UF P/M20% 10VDC TANTALUM	10098-0002
C15	750UF P/M20% 10VDC ELECTROLYTIC	10101-0001
DIODES		
CR1	1N2973A	12002-0100
CR2	1N645	2088156-0001
CR3	1N645	2088156-0001
CR4	1N645	2088156-0001
CR5	1N4003 ADDED EFFECTIVE S/N28127 AND ABOVE (551A) ADDED EFFECTIVE S/N3741 AND ABOVE (551E) ADDED EFFECTIVE S/N2674 AND ABOVE (551RL)	12042-0031
CR6	1N4003 ADDED EFFECTIVE S/N28127 AND ABOVE (551A) ADDED EFFECTIVE S/N3741 AND ABOVE (551E) ADDED EFFECTIVE S/N2674 AND ABOVE (551RL)	12042-0031
CR7	1N4003 ADDED EFFECTIVE S/N28127 AND ABOVE (551A) ADDED EFFECTIVE S/N3741 AND ABOVE (551E) ADDED EFFECTIVE S/N2674 AND ABOVE (551RL)	12042-0031
CR8	1N4003 ADDED EFFECTIVE S/N28127 AND ABOVE (551A) ADDED EFFECTIVE S/N3741 AND ABOVE (551E) ADDED EFFECTIVE S/N2674 AND ABOVE (551RL)	12042-0031
JACKS		
J1	GK-9-32S 9-PIN (EXCEPT 551E)	24062-0001
J1	GK-12-32S (551E ONLY)	24062-0012
J2	WK-4-32S 4-PIN	24062-0010
J3	WK-6-32S 6-PIN	24062-0004
INDUCTORS		
L1	CHOKE	90A068-0001
L2	CHOKE	90A068-0001

Bendix Avionics Division

SECTION V.
PARTS LISTS
SERVO AMPLIFIER-INDICATOR CHASSIS
ELECTRICAL PARTS LIST

REF DESIG	DESCRIPTION	BENDIX PART NUMBER
TRANSISTORS		
Q1	2N1304	12046-0005
Q1	2N2222A	12051-0003
	EFFECTIVE MOD 4 S/N31778 (551A)	
	EFFECTIVE MOD 4 S/N3812 (551E)	
	EFFECTIVE MOD 4 S/N5445 (551RL)	
Q2	2N1193	12045-0025
Q3	2N1193	12045-0025
Q4	2N1193	12045-0025
Q5	SA319	12045-0083
Q5	2N1193	12045-0025
	ADDED EFFECTIVE S/N28127 AND ABOVE (551A)	
	ADDED EFFECTIVE S/N3741 AND ABOVE (551E)	
	ADDED EFFECTIVE S/N2674 AND ABOVE (551RL)	
Q6	SA319	12045-0083
Q6	2N1193	12045-0025
	ADDED EFFECTIVE S/N28127 AND ABOVE (551A)	
	ADDED EFFECTIVE S/N3741 AND ABOVE (551E)	
	ADDED EFFECTIVE S/N2674 AND ABOVE (551RL)	
Q7	2N1191	12045-0027
Q8	2N1191	12045-0027
Q9	2N3414	12047-0013
	ADDED EFFECTIVE S/N28127 AND ABOVE (551A)	
	ADDED EFFECTIVE S/N3741 AND ABOVE (551E)	
	ADDED EFFECTIVE S/N2674 AND ABOVE (551RL)	
Q10	2N3414	12047-0013
	ADDED EFFECTIVE S/N28127 AND ABOVE (551A)	
	ADDED EFFECTIVE S/N3741 AND ABOVE (551E)	
	ADDED EFFECTIVE S/N2674 AND ABOVE (551RL)	
RESISTORS		
R1	NOT USED	
R2	75 OHMS P/M10% 7W WW	11047-750K
R3	25 OHMS P/M10% 3W WW	11040-250K
R4	4.7K OHMS P/M5% 1/4W COMPOSITION	11011-472J
R5	4.7K OHMS P/M5% 1/4W COMPOSITION	11011-472J
R6	150 OHMS P/M10% 1/2W COMPOSITION	11012-151K
R7	8.2K P/M10% 1/4W COMPOSITION	11011-822K
R8	470 OHMS P/M10% 1/4W COMPOSITION	11011-471K
R8	1K OHMS P/M10% 1/4W COMPOSITION	RC07GF102K
	EFFECTIVE MOD 4 S/N31778 (551A)	
	EFFECTIVE MOD 4 S/N3812 (551E)	
	EFFECTIVE MOD 4 S/N5445 (551RL)	
R9	100 OHMS P/M10% 1/4W COMPOSITION	11011-101K
R10	2.2K OHMS P/M10% 1/4W COMPOSITION	11011-222K
R11	2.7K OHMS P/M10% 1/4W COMPOSITION	11011-272K
R12	1.2K OHMS P/M10% 1/4W COMPOSITION	11011-122K
R13	180 OHMS P/M10% 1/4W COMPOSITION	11011-181K
R14	15K OHMS P/M10% 1/4W COMPOSITION	11011-153K
R15	2.2K OHMS P/M20% 2W VARIABLE	11063-0001
R16	10 OHMS P/M10% 1/2W COMPOSITION	11012-100K
R17	1K OHMS P/M10% 1/4W COMPOSITION	11011-102K
R18	2.2K OHMS P/M10% 1/4W COMPOSITION	11011-222K
R19	10 OHMS P/M10% 1/2W COMPOSITION	11012-100K
R20	2.2K OHMS P/M10% 1/4W COMPOSITION	11011-222K
R21	220 OHMS P/M10% 1/2W COMPOSITION	11012-221K

Bendix Avionics Division

SECTION V.
PARTS LISTS
SERVO AMPLIFIER-INDICATOR CHASSIS
ELECTRICAL PARTS LIST

REF DESIG	DESCRIPTION	BENDIX PART NUMBER
R22	2.2K OHMS P/M10% 1/4W COMPOSITION	11011-222K
R23	100 OHMS P/M10% 1/4W COMPOSITION	11011-101K
R24	330 OHMS P/M10% 1/4W COMPOSITION	11011-331K
R25	20 OHMS P/M20% 2W VARIABLE	11062-0001
R25	40 OHMS P/M20% 2W VARIABLE	11062-0007
	EFFECTIVE MOD 3 S/N31581 (551A)	
	EFFECTIVE MOD 3 S/N3804 (551E)	
	EFFECTIVE MOD 3 S/N5171 (551RL)	
R26	10 OHMS P/M10% 1/2W COMPOSITION	11012-100K
R27	27K OHMS P/M10% 1/4W COMPOSITION	11011-273K
R28	4.7K OHMS P/M5% 1/4W COMPOSITION	RC07GF472J
	ADDED EFFECTIVE S/N28127 AND ABOVE (551A)	
	ADDED EFFECTIVE S/N3741 AND ABOVE (551E)	
	ADDED EFFECTIVE S/N2674 AND ABOVE (551RL)	
R29	4.7K OHMS P/M5% 1/4W COMPOSITION	RC07GF472J
	ADDED EFFECTIVE S/N28127 AND ABOVE (551A)	
	ADDED EFFECTIVE S/N3741 AND ABOVE (551E)	
	ADDED EFFECTIVE S/N2674 AND ABOVE (551RL)	
THERMISTORS		
RT1	250 OHMS P/M10% DISC	11030-0001
TRANSFORMERS		
T1	TRANSFORMER, OSCILLATOR	90A044-0001

Document is protected
Not for re-sale
For informational use
only

Bendix Avionics Division

Document is protected
Not for re-sale
For informational use
only

SECTION V.
PARTS LISTS
 102A/102B AUDIO AMPLIFIER
 ELECTRICAL PARTS LIST

REF DESIG	DESCRIPTION	BENDIX PART NUMBER
	AUDIO AMPLIFIER, MODEL 102A	1U041-01
	AUDIO AMPLIFIER, MODEL 102B	1U041-02
	CAPACITORS	
C1	500UF P/M10% 50VDC ELECTROLYTIC	10101-0004
C2	0.047UF P/M20% 100VDC MYLAR	10083-0030
	JACKS	
J1		24085-0003
	INDUCTORS	
L1	CHOKE, INPUT FILTER	90A067-01
	TRANSISTORS	
Q1	SP764 -MODEL 102A ONLY-	12001-0075
Q1	SP1141 -MODEL 102A ONLY-	12001-0082
Q2	SP764 -MODEL 102A ONLY-	12001-0075
Q2	SP1141 -MODEL 102A ONLY-	12001-0082
	RESISTORS	
R1	680 OHMS P/M10% 1/2W COMPOSITION	RC203F681K
R2	680 OHMS P/M10% 1/2W COMPOSITION	RC20GF681K
R3	1.8 OHMS P/M10% 2W	11064-0005
R4	1.8 OHMS P/M10% 2W	11064-0005
	TRANSFORMERS	
T1	AUDIO DRIVER	90A066-01
T2	AUDIO DRIVER	90A065-01

Bendix Avionics Division

Document is protected
Not for re-sale
For informational use
only

SECTION VI
SCHEMATIC DIAGRAMS

6-1. GENERAL

This section contains schematic diagrams of Model 201F Receiver and its associated Model 551() Indicator and Model 2321E Fixed Loop Antenna. In addition, a wiring diagram is provided for field modification of the model 551() servo amplifier indicator for an installation with a bottom mounted sense antenna.

Document is protected
Not for re-sale
For informational use
only

Document is protected
Not for re-sale
For informational use
only

SECTION VI
SCHEMATIC DIAGRAMS

SUMMARY OF CHANGES TO
201F ADF RECEIVER SCHEMATIC DIAGRAM
NUMBER 4000411, SHEET 1

SCHEMATIC ISSUE	DESCRIPTION OF CHANGE	SERVICE BULLETIN NUMBER *	EFFECTIVITY UNIT S/N
A and B	Changes made prior to release.		
C	Changed value of C21 from 90 pf to 68 pf to provide center tuning of trimmer C22.	1	1166
	Changed values of following capacitors to improve ADF servo loop output voltage: C10 from 560 pf to 330 pf. C11 from 160 pf to 120 pf. C12 from 100 pf to 68 pf.		1210
D	Changed reference designator CR13 (varactor connected to C1) to CR19 to correct error.		
	Added R90 (270 kilohms) to collector of Q7 to improve i-f amplifier stability.		1200
	Changed C21 from 68 pf to a test select and added note 6 to provide center tuning of trimmer C22.		1601
	Deleted wire from R55 to C58 and added R61 (270 ohms) and C78 (39 μ f) to remove audio feedback on the AGC bus.		1601
E	Changed C21 to a fixed value (68 pf) and changed C65 (27 pf) to a test select. Moved note 6 reference designator from C21 to C65. Changed the value of the following: C36 from 5-30-pf to 8-50-pf. C37 from 5-30-pf to 8-50-pf. C39 from 5-30-pf to 8-50-pf. R88 from 39 kilohms to 24 kilohms. R89 from 11 kilohms to 7500 ohms.		2513
	Change was made to increase adjustment range.		

* See Service Bulletin List in front of Manual.

SECTION VI
SCHEMATIC DIAGRAMS

SUMMARY OF CHANGES TO
201F ADF RECEIVER SCHEMATIC DIAGRAM
NUMBER 4000411, SHEET 1

SCHEMATIC ISSUE	DESCRIPTION OF CHANGE	SERVICE BULLETIN NUMBER *	EFFECTIVITY UNIT S/N
	Changed C65 to a fixed value (27 pf) and changed C21 to a test select. Moved note 6 reference designator from C65 to C21. Change was made to compensate for vendor change in CR14.		2538
	Changed reference designator C76 (.1 μ f connected to Q3) to C78 to correct error.		1166
F	<p>Changed values of following parts due to unavailability of ED1808 diodes:</p> <p>CR1 from ED1808 to IN914. CR2 from ED1808 to IN914. CR3 from ED1808 to IN914. CR4 from ED1808 to IN914. R5 from 3900 ohms to 2700 ohms. R6 from 3900 ohms to 2700 ohms. R17 from 15 kilohms to 22 kilohms.</p>		
	Deleted CR7 (ED1808), R18 (10 kilohms), R19 (120 kilohms), and moved C31 (.1 μ f) to connect to Q4 emitter and ground. Change was a cost reduction.		2850
	Replaced CR21 (IN4003) with R96 (6.8 ohm) to reduce dissipation of Q115.		2850
	Added C79 to reduce 1 kHz interference on the tuning bus. Value of C79 is test selected.		2850
G	Moved L14 (1.0 mh) out of OPTIONAL AUDIO AMP + line to eliminate voltage drop.		2883
H	<p>Changed the following parts to replace germanium with silicon:</p> <p>Q1, Q2, Q3, Q4 from 2N1637 to MPS6516. Q6, Q7, Q8 from 2N1638 to MPS6516. CR5, CR9, CR10, CR11 from ED1808 to IN117. R4 from 4700 ohms to 3000 ohms R17 from 22 kilohms to 15 kilohms. R35 from 6800 ohms to 3900 ohms.</p>		2883

* See Service Bulletin List in front of Manual.

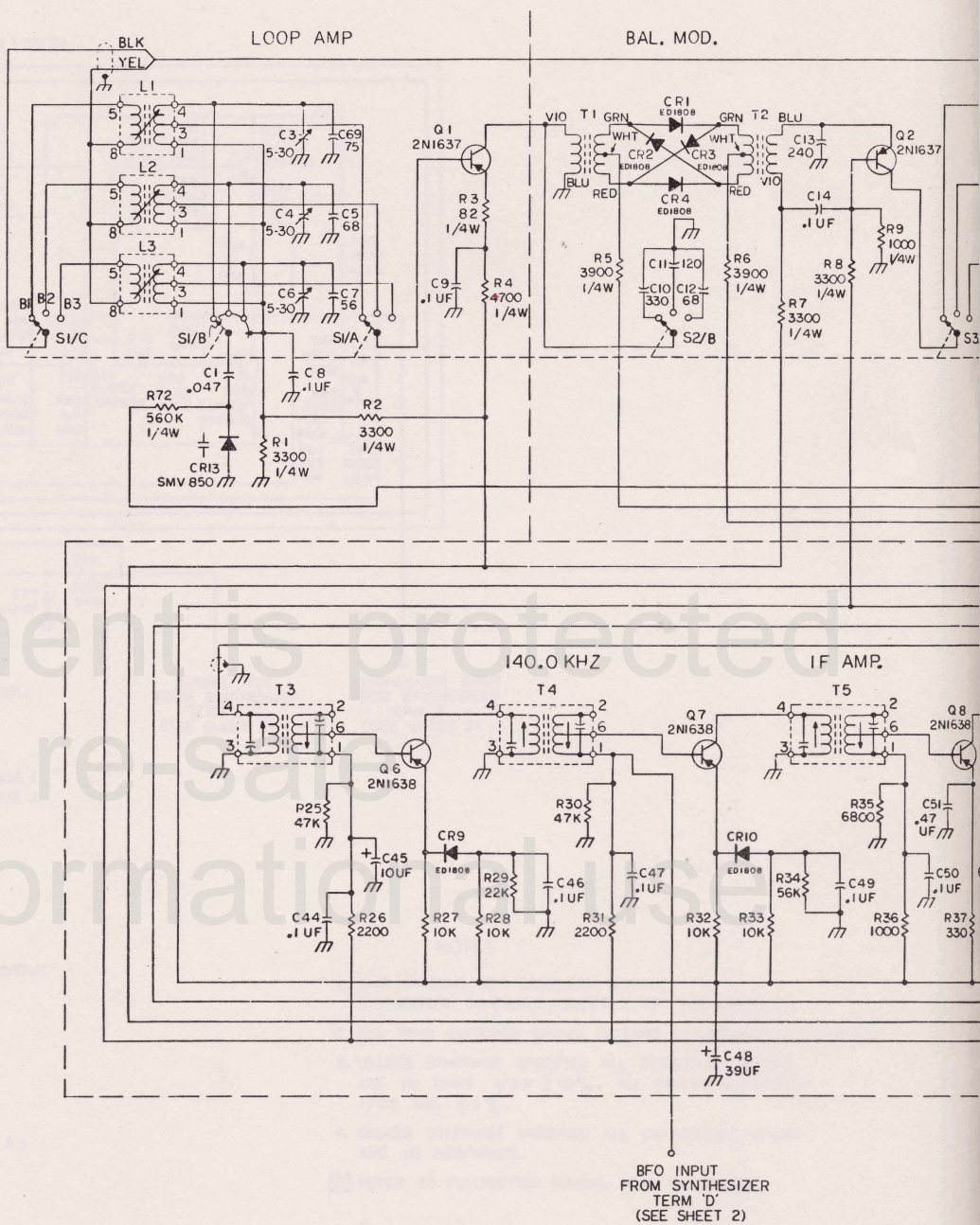
SECTION VI
SCHEMATIC DIAGRAMS

SUMMARY OF CHANGES TO
201F ADF RECEIVER SCHEMATIC DIAGRAM
NUMBER 4000411, SHEET 1

SCHEMATIC ISSUE	DESCRIPTION OF CHANGE	SERVICE BULLETIN NUMBER *	EFFECTIVITY UNIT S/N
	Deleted R41 (4700 ohms) and RT1 (2700 ohms).		
J	Corrected error.		N/A
K	Changed reference designator C78 (.1 uf connected to Q3) to C80. Changed reference designator C69 (75 pf connected to L1 pin 4) to C68. Changes made to correct errors.		
L	Changed C65 (27 pf) to a test select to provide center setting of trimmer C22.		5295
M	Changed value of R51 from 2000 ohms to 500 ohms to reduce low level audio distortion.	T12-011	5295
N	Changed value of C69 from 20 uf to 22 uf. 20 uf capacitor no longer available		N/A
P	Added R20, R21, and R24 to improve bearing accuracy by reducing rf feedback and lowering Q of tuned circuits in the rf amplifier circuit.	T12-013	5868
R	Corrected error.		N/A
S	Added CR22 and CR23 to provide additional transient protection for varicap diodes in rf amplifier.	T12-017	6602
T	Changed value of C10 from 330 pF to 560 pF and changed value of C11 from 120 pF to 270 pF. Changes made to reduce loop signal modulation.	T12-014	7263

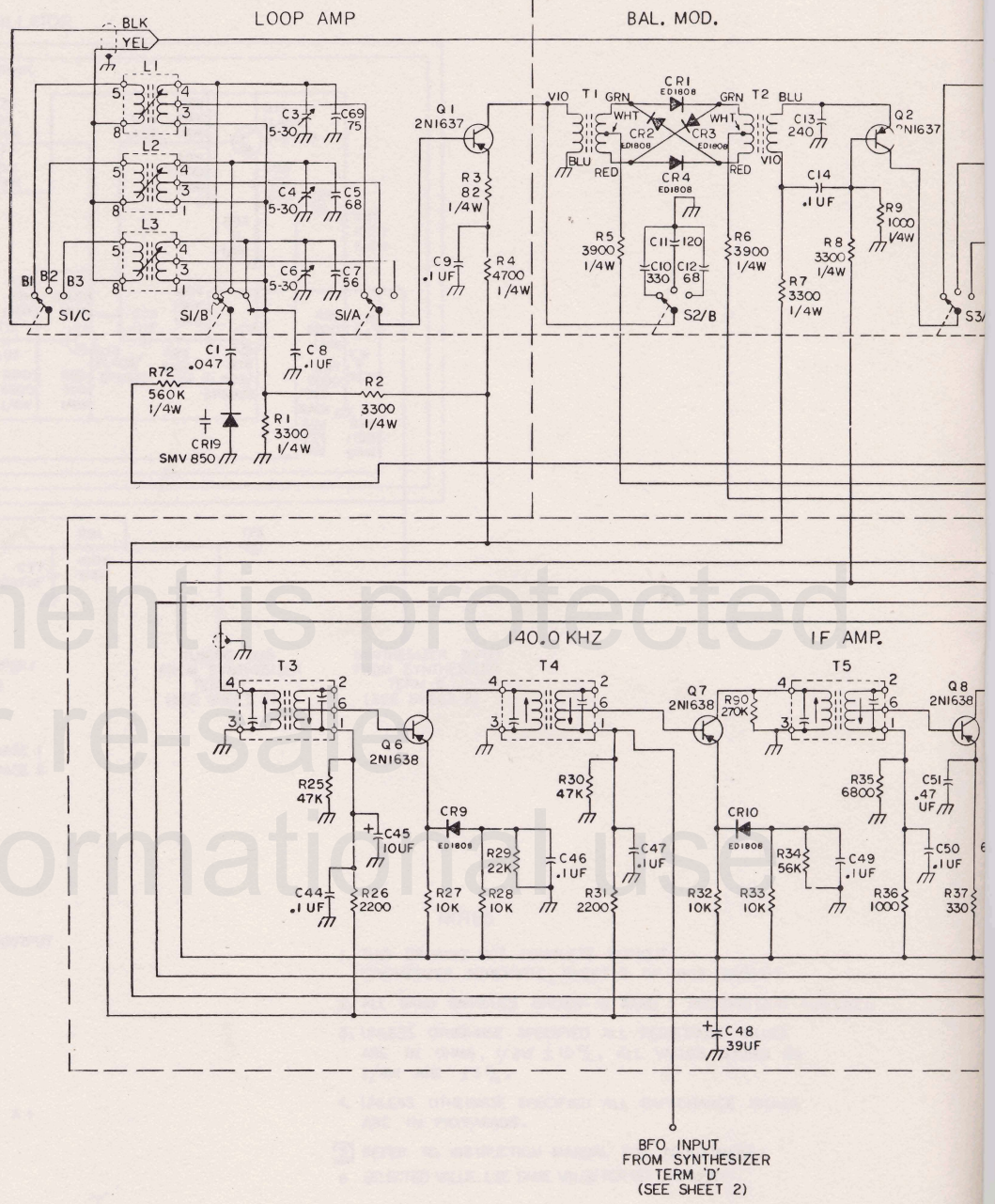
* See Service Bulletin List in front of Manual.

SECTION VI
SCHEMATIC DIAGRAM



Document is protected
Not for re-sale
For information only

SECTION VI
 SCHEMATIC DIAGRAMS



Document is protected
 Not for re-sale
 For informational use
 only

4000411-0000
 E

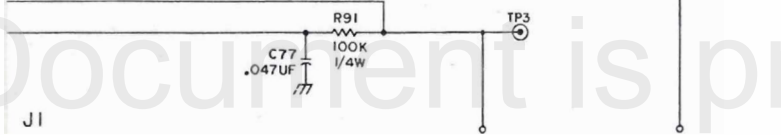
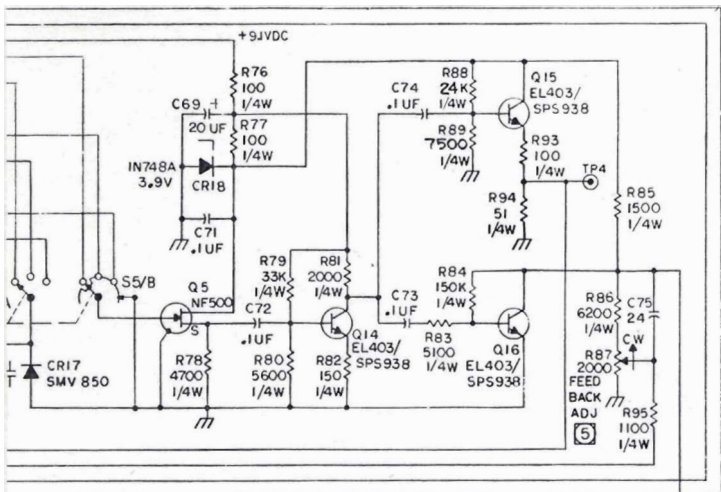
201F ADF Receiver Schematic Diagram

Figure 10

I.B. 2012B

SECTION VI
SCHEMATIC DIAGRAMS

TAGE CONTROLLED OSCILLATOR



- J1
- 4 LOOP INPUT R2 (COPPER)
 - 3 LOOP INPUT R1 (TIN)
 - 2 LOOP SHIELD
 - 1 SENSE ANTENNA
 - 12 47Ω SWITCHING, PHASE 1
 - 8 47Ω SWITCHING, PHASE 2
 - 14 HEADSET (500Ω)
 - 9 GROUND

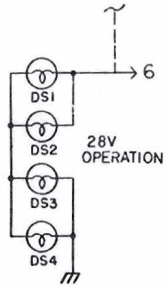
TUNING BUS FROM SYNTHESIZER TERM 'A' (SEE SHEET 2)

SYNTHESIZER INPUT FROM SYNTHESIZER TERM 'B' (SEE SHEET 2)

- 16 ADF SERVO SIGNAL OUTPUT
- 7 SPARE
- 11 SPARE
- 15 DC IN
- 5 OPTIONAL AUDIO AMP A +
- 13 SERVO DC OUTPUT
- 10 SERVO DC OUTPUT

→ 6 DIAL LAMPS

14V OPERATION



NOTES

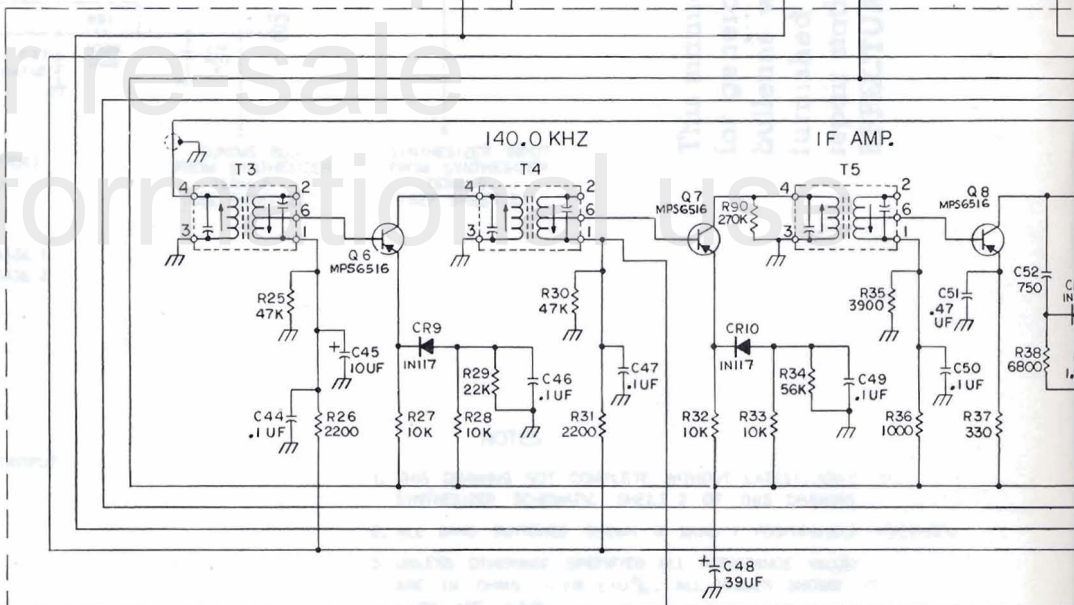
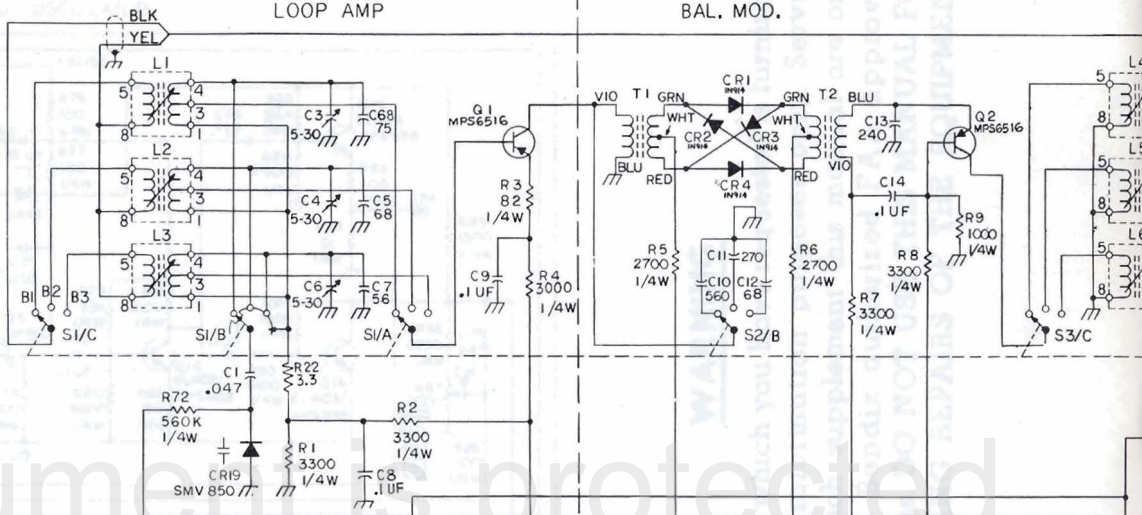
1. THIS DRAWING NOT COMPLETE WITHOUT SYNTHESIZER SCHEMATIC, SHEET 2 OF THIS DRAWING.
2. ALL BAND SWITCHES SHOWN IN BAND 1 POSITION (200-400 KHZ).
3. UNLESS OTHERWISE SPECIFIED ALL RESISTANCE VALUES ARE IN OHMS, 1/2W ±10%. ALL VALUES SHOWN AS 1/4W ARE ±5%.
4. UNLESS OTHERWISE SPECIFIED ALL CAPACITANCE VALUES ARE IN PICOFARADS.
- 5 REFER TO INSTRUCTION MANUAL FOR ADJUSTMENT.
- 6 SELECTED VALUE, USE SAME VALUE FOR REPLACEMENT.

201F ADF Receiver, Schematic Diagram
(Issue E)
Figure 6-1 (Sheet 1 of 2)

CONTROL UNIT

LOOP AMP

BAL. MOD.



BFO INPUT
FROM SYNTHESIZER
TERM 'D'
(SEE SHEET 2)

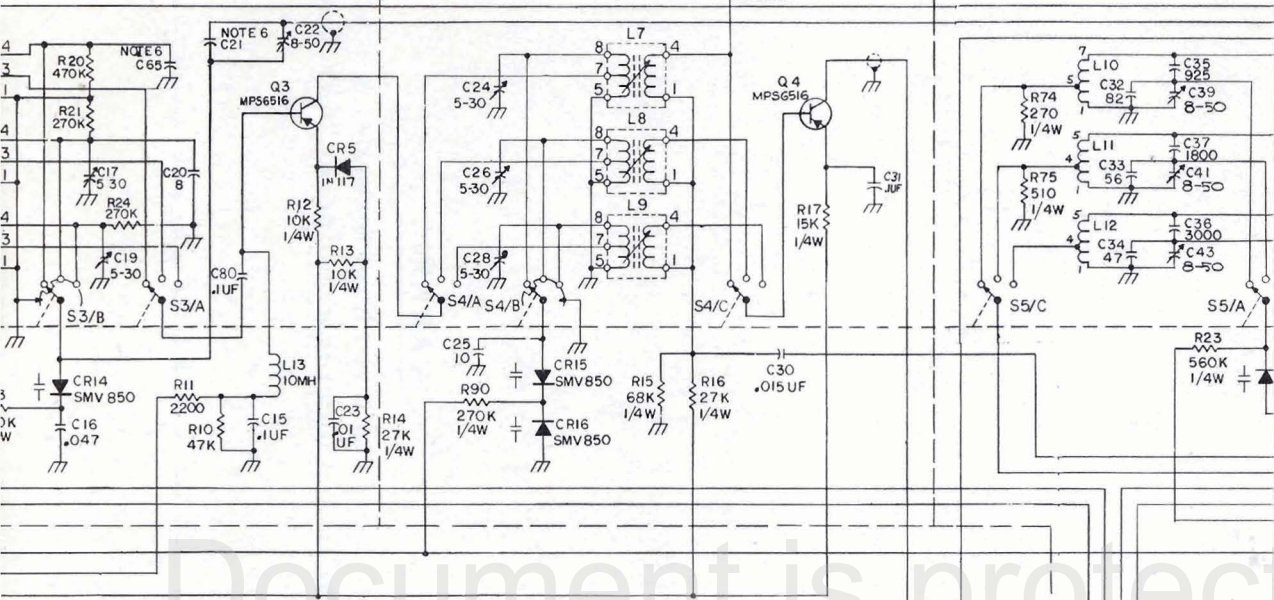
4000411-0000
T

Document is protected
Not for re-sale
For information only

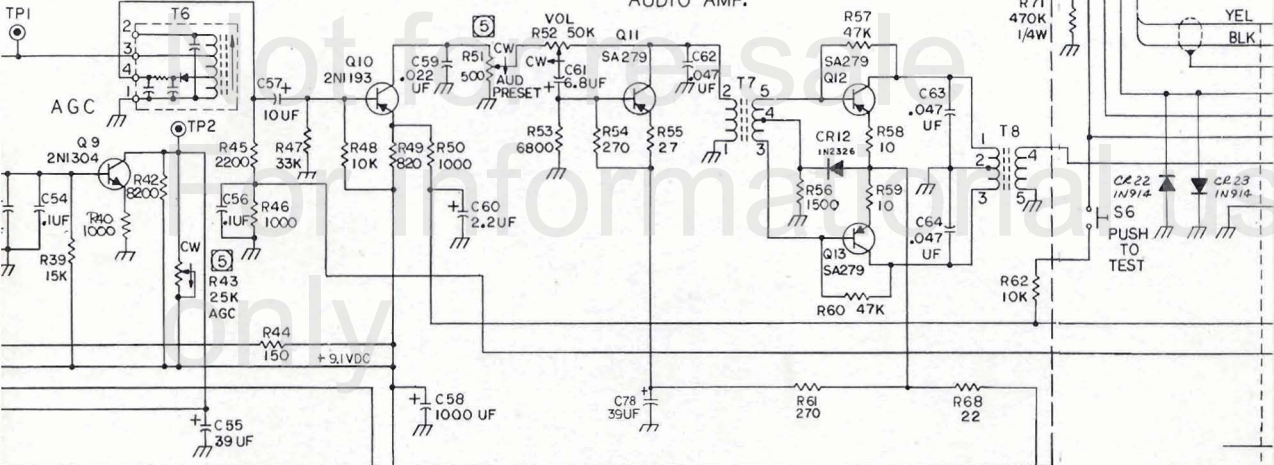
RF AMP.

MIXER

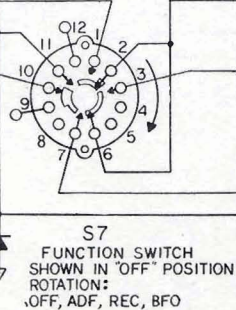
VOLTAG



AUDIO AMP.



BFO CONTROL
TO SYNTHESIZER
TERM 'C'
(SEE SHEET 2)



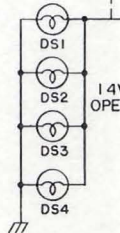
S7
FUNCTION SWITCH
SHOWN IN "OFF" POSITION
ROTATION:
.OFF, ADF, REC, BFO

MONITOR CONTROL
TO SYNTHESIZER
TERM 'E'
(SEE SHEET 2)

MONITOR LAMP

INPUT TO 5V REG
TO SYNTHESIZER
TERM 'A'
(SEE SHEET 2)

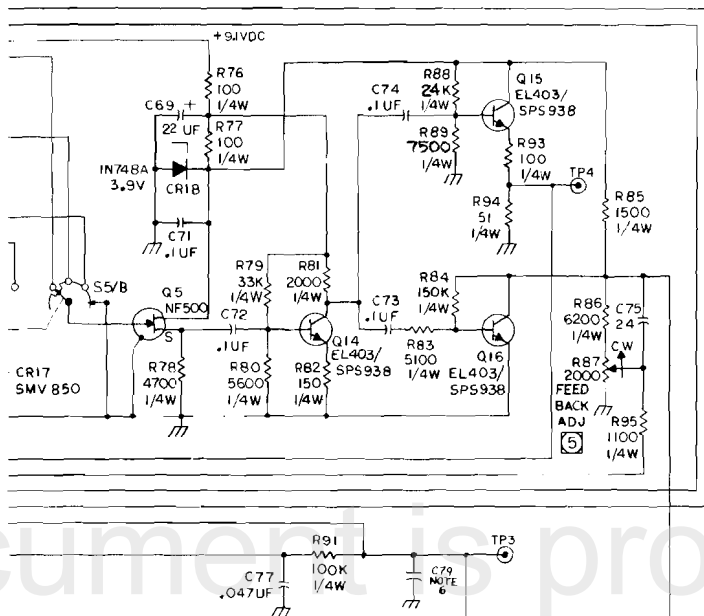
C76
100UF



14V
OPE

SECTION VI
SCHEMATIC DIAGRAMS

E CONTROLLED OSCILLATOR



WARNING

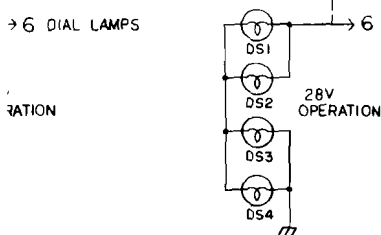
This manual which you have requested is furnished for general information purposes only. Service bulletins which supplement this manual are only furnished to Bendix authorized FAA approved repair stations. DO NOT USE THIS MANUAL FOR EFFECTUATING REPAIRS OF THE EQUIPMENT.

- >4 LOOP INPUT R2 (COPPER)
 - >3 LOOP INPUT R1 (TIN)
 - >2 LOOP SHIELD
 - >1 SENSE ANTENNA
 - >12 47Ω SWITCHING, PHASE 1
 - >8 47Ω SWITCHING, PHASE 2
 - >14 HEADSET (500Ω)
 - >9 GROUND
- TUNING BUS FROM SYNTHESIZER TERM 'F' (SEE SHEET 2)
- SYNTHESIZER INPUT FROM SYNTHESIZER TERM 'B' (SEE SHEET 2)

- >16 ADF SERVO SIGNAL OUTPUT
- >7 TUNING METER
- >11 SPARE
- >15 DC IN
- >5 OPTIONAL AUDIO AMP A+
- >13 SERVO DC OUTPUT
- >10 SERVO DC OUTPUT

NOTES

1. THIS DRAWING NOT COMPLETE WITHOUT LATEST ISSUE OF SYNTHESIZER SCHEMATIC, SHEET 2 OF THIS DRAWING.
2. ALL BAND SWITCHES SHOWN IN BAND 1 POSITION (200-400 KHz).
3. UNLESS OTHERWISE SPECIFIED ALL RESISTANCE VALUES ARE IN OHMS, 1/2W ±10%. ALL VALUES SHOWN AS 1/4W ARE ±5%.
4. UNLESS OTHERWISE SPECIFIED ALL CAPACITANCE VALUES ARE IN PICO FARADS.
5. REFER TO INSTRUCTION MANUAL FOR ADJUSTMENT.
6. SELECTED VALUE. USE SAME VALUE FOR REPLACEMENT.



201F ADF Receiver, Schematic Diagram
(Issue T)
Figure 6-1 (Sheet 1 of 2)

SECTION VI
SCHEMATIC DIAGRAMS

SUMMARY OF CHANGES TO
201F ADF RECEIVER SCHEMATIC DIAGRAM
DRAWING NO. 4000411 SHEET 2

SCHEMATIC ISSUE	DESCRIPTION OF CHANGE	SERVICE BULLETIN NUMBER *	EFFECTIVITY UNIT S/N
A&B	Changes made prior to release.		
C	Changed values of R101 from 470 kilohms to 1 megohm, and R102 from 120 kilohms to 240 kilohms to improve low temperature operation. Added C119 (.1 μ f) and L102 (220 μ h) to reduce noise susceptibility. Added C131 (.1 μ f) and R161 (3.3 kilohms) to reduce ripple on tuning bus. Added R161 through R168 (all 2200 ohms) to improve noise immunity.	1	1166 1166 1166 1166
D	Deleted CR112 (IN914), R135 (39 kilohms), C112 (.1 μ f), and CR114 (IN959B, 8.2V). Added resistor R128 (3000 ohms) in series with R124 and diode CR114 (IN4350, 2.4V) in parallel with R124. Changed the following part values: R160 from 100 ohms to 270 ohms. R124 from 10K ohms to 6200 ohms. R125 from 75K ohms to 51K ohms. R126 from 2K (nom.) ohms to 1300 ohms. R131 from 4300 ohms to 1800 ohms. R156 from 22 ohms to 47 ohms. R134 from 4300 ohms to 47K ohms. Change was made to improve: i-f stability, temperature variation performance, r-f tuning, and monitor lamp operation.		1601
E	Added C112 (.022 μ f) in parallel with R131 and changed the value of C131 from .1 μ f to .022 μ f to stabilize the synthesizer loop at high audio frequencies.	2	1532
F	Changed value of R160 from 270 ohms to 180 ohms to raise voltage across CR16 to 5.1V. Added CR117 (IN755A, 7.5V) to R156 to stabilize the tuning bus voltage.	3	3086 3096 thru 3099, 3102, 3116, 3118 & above

* See Service Bulletin List in front of Manual.

SECTION VI
SCHEMATIC DIAGRAMS

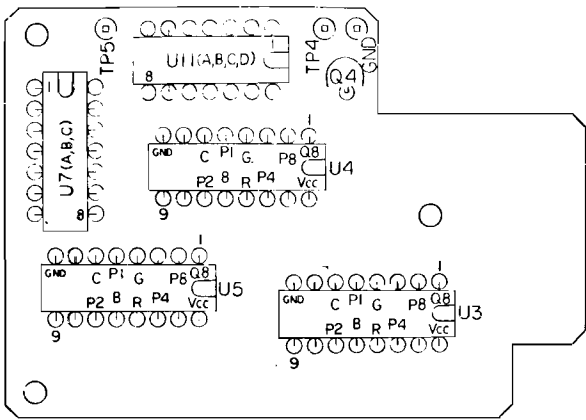
SUMMARY OF CHANGES TO
201F ADF RECEIVER SCHEMATIC DIAGRAM
DRAWING NO. 4000411 SHEET 2

SCHEMATIC ISSUE	DESCRIPTION OF CHANGE	SERVICE BULLETIN NUMBER *	EFFECTIVITY UNIT S/N
G	Error correction		N/A
H	Changed value of C103, C104, C109, C116, C117, C121 from 20 uf to 22 uf. 20 uf capacitor no longer available.		N/A

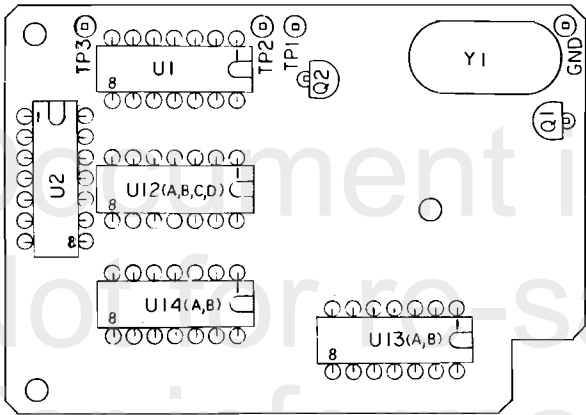
Document is protected
Not for re-sale
For informational use
only

* See Service Bulletin List in front of Manual.

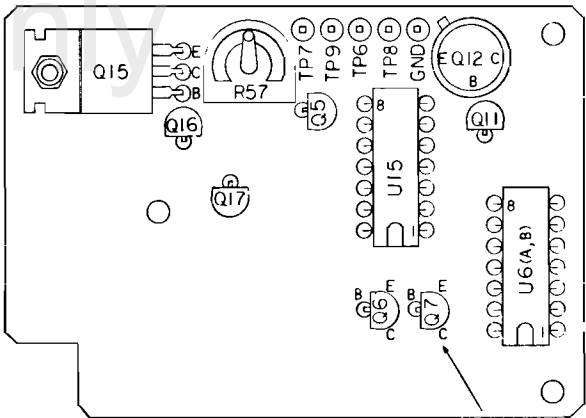
Part of Figure 6-1 Sheet 2
201F ADF Receiver, Schematic Diagram



COUNTER BOARD



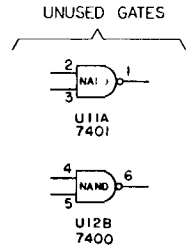
CLOCK - OFFSET BOARD



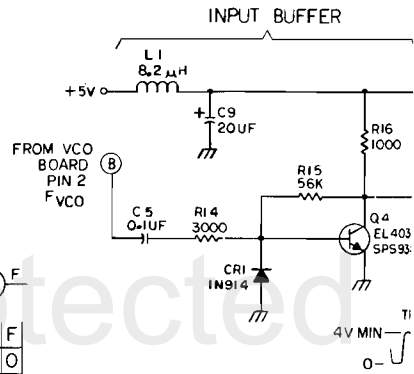
REGULATOR - DETECTOR BOARD

TYPICAL PIN ARRANGEMENT FOR ALL TO-92 TRANSISTORS

4000411
C



+ C4
20 UF



AND

A	B	F
0	0	0
0	1	0
1	0	0
1	1	1

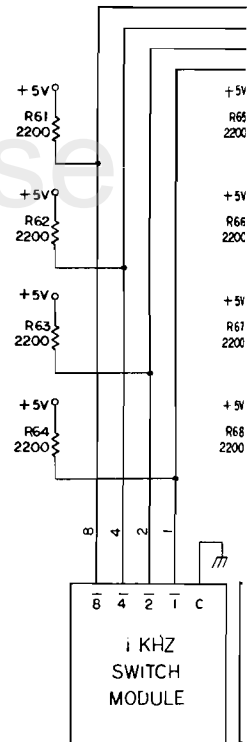
NAND

A	B	F
0	0	1
0	1	1
1	0	1
1	1	0

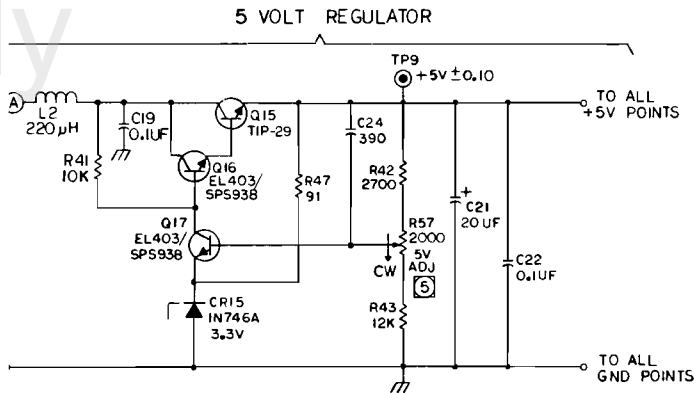
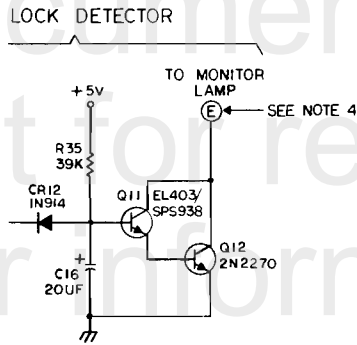
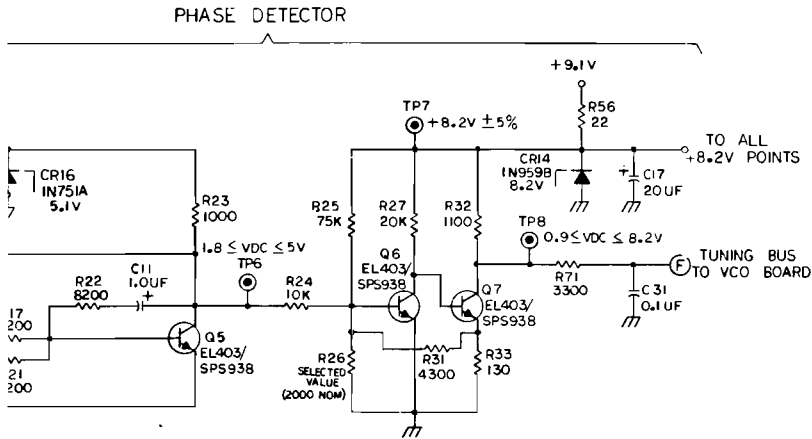
NOR

A	B	F
0	0	1
0	1	0
1	0	0
1	1	0

TRUTH TABLES



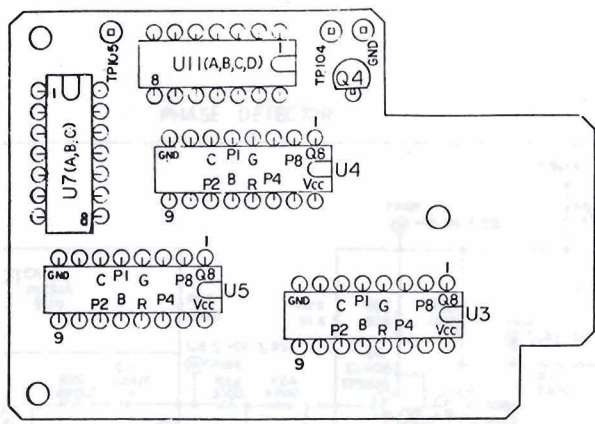
SECTION VI
SCHEMATIC DIAGRAMS



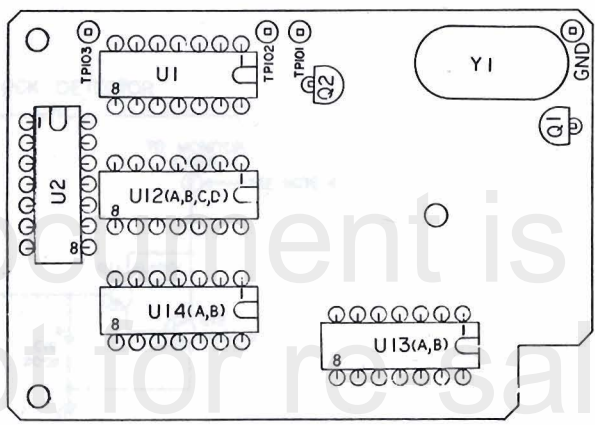
NOTES

1. ADD 100 TO ALL CIRCUIT SYMBOL NUMBERS
2. ALL RESISTANCE VALUES ARE IN OHMS, 1/4W, 5%
3. ALL CAPACITANCE VALUES ARE IN PICAFARADS UNLESS OTHERWISE SPECIFIED.
4. (E) INDICATES TERMINAL LETTER FROM SHEET 1
5. REFER TO INSTRUCTION MANUAL FOR ADJUSTMENT

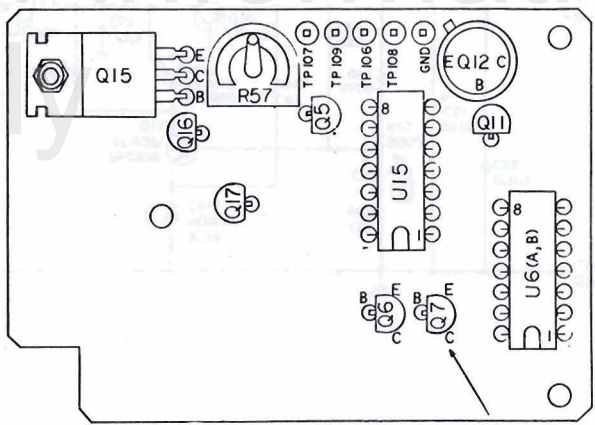
201F ADF Receiver, Schematic Diagram
(Issues A through C)
Figure 6-1 (Sheet 2 of 2)



COUNTER BOARD



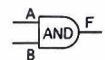
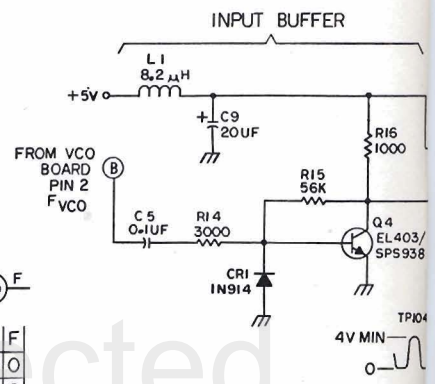
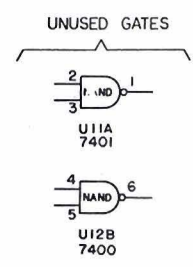
CLOCK - OFFSET BOARD



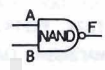
REGULATOR - DETECTOR BOARD

TYPICAL PIN ARRANGEMENT FOR ALL TO-92 TRANSISTORS

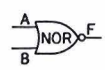
4000411
E



A	B	F
0	0	0
0	1	0
1	0	0
1	1	1

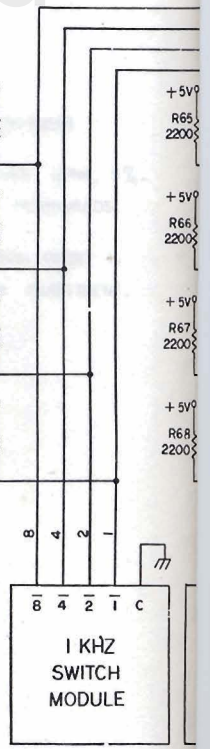


A	B	F
0	0	1
0	1	1
1	0	1
1	1	0



A	B	F
0	0	1
0	1	0
1	0	0
1	1	0

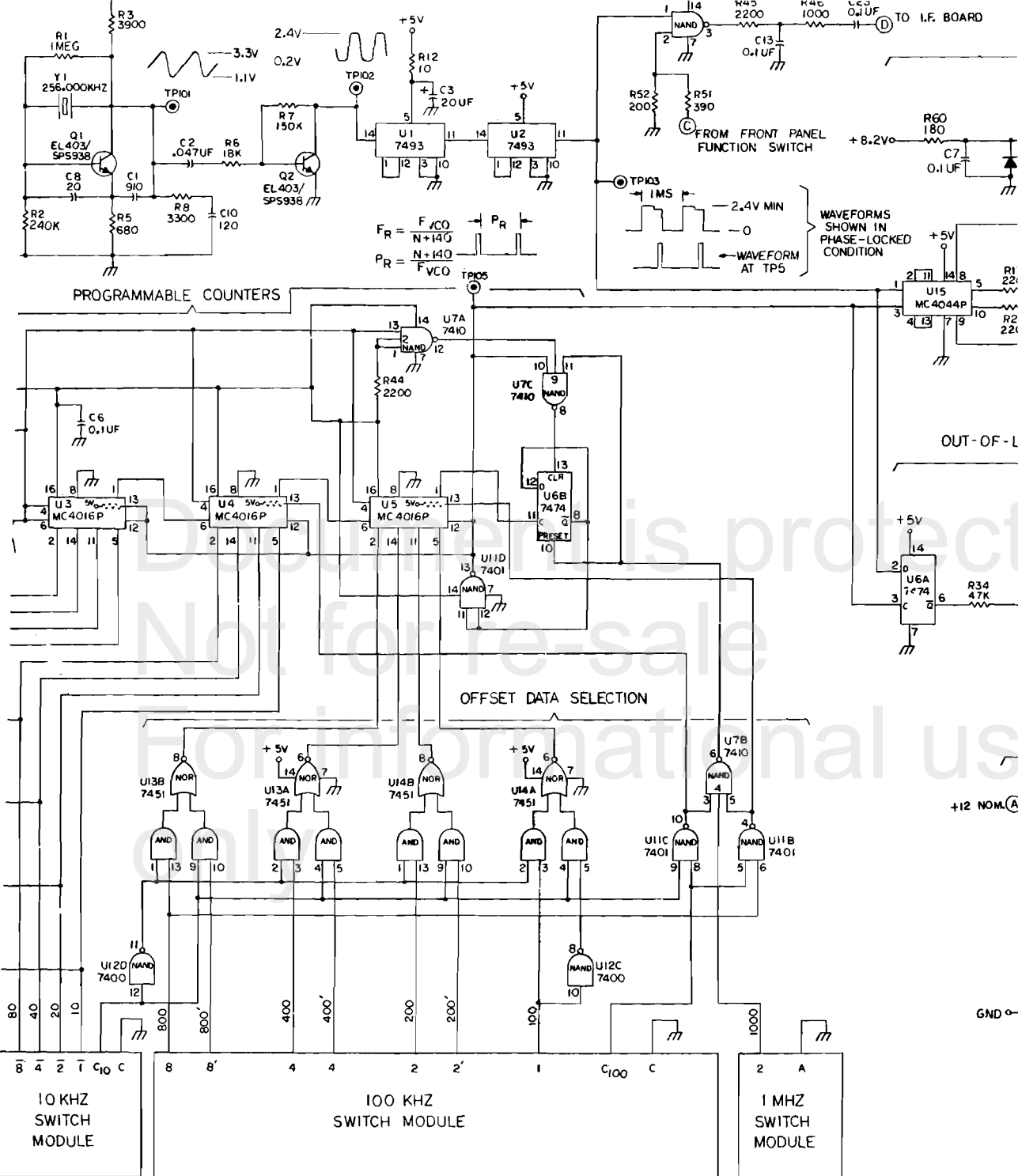
TRUTH TABLES



201P ADP Receiver, Schematic Diagram

Figure 1 (Sheet 1 of 2)

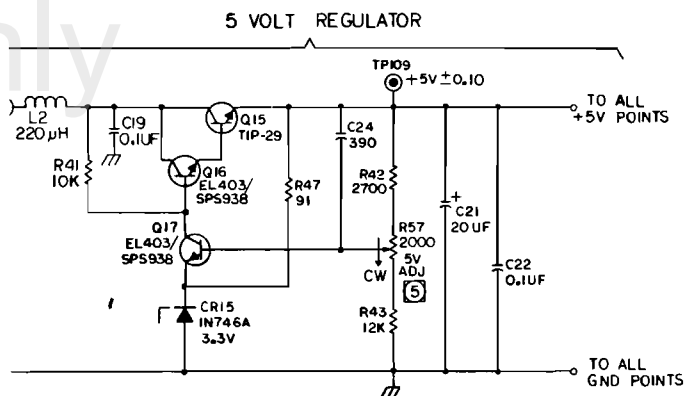
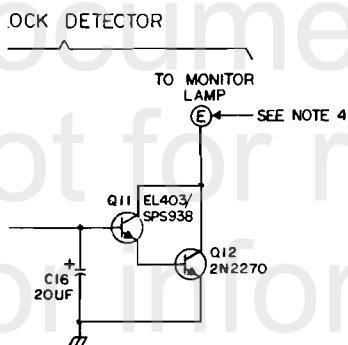
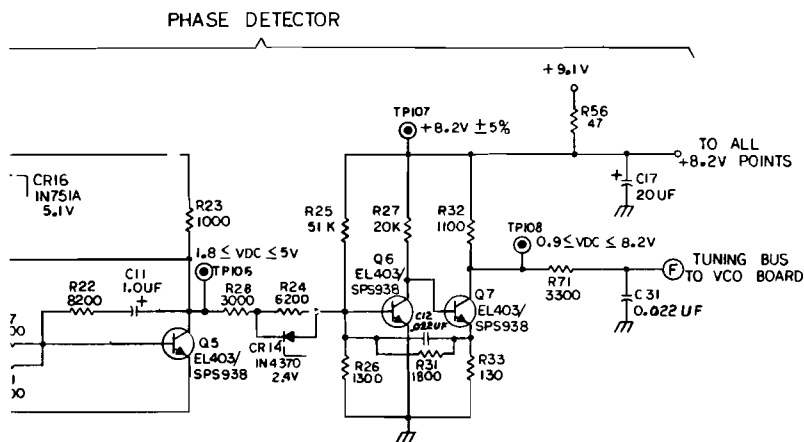
Rev. 1-72



Not for sale

Informational use

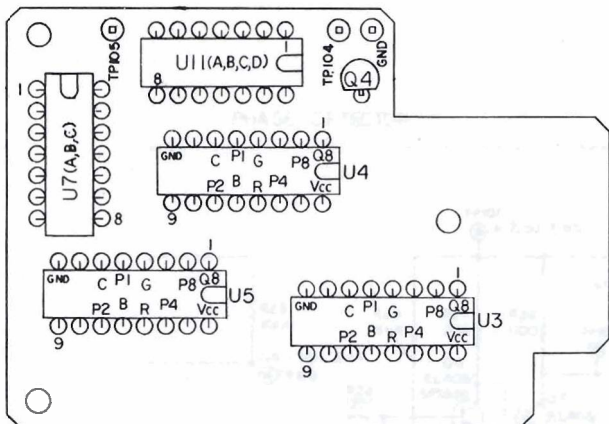
SECTION VI
SCHEMATIC DIAGRAMS



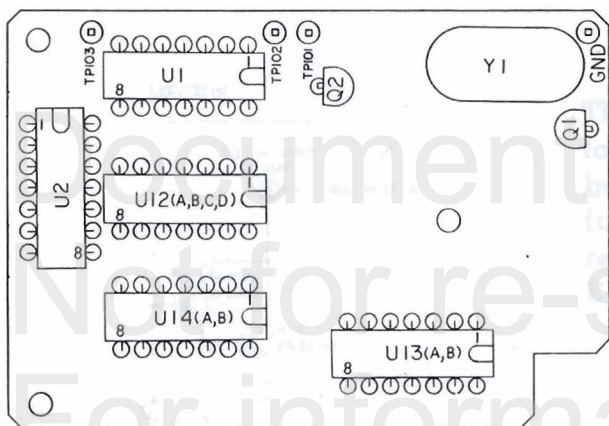
NOTES

1. ADD 100 TO ALL CIRCUIT SYMBOL NUMBERS EXCEPT TEST POINTS.
2. ALL RESISTANCE VALUES ARE IN OHMS, 1/4W, 5%
3. ALL CAPACITANCE VALUES ARE IN PICOFARADS, UNLESS OTHERWISE SPECIFIED.
4. (E) INDICATES TERMINAL LETTER FROM SHEET 1.
5. REFER TO INSTRUCTION MANUAL FOR ADJUSTMENT

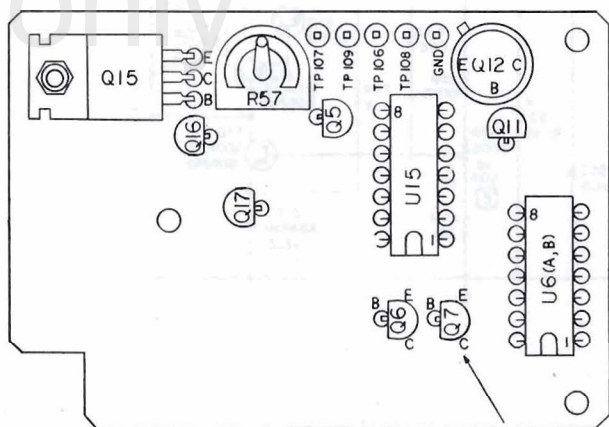
201F ADF Receiver, Schematic Diagram
(Issue E)
Figure 6-1 (Sheet 2 of 2)



COUNTER BOARD

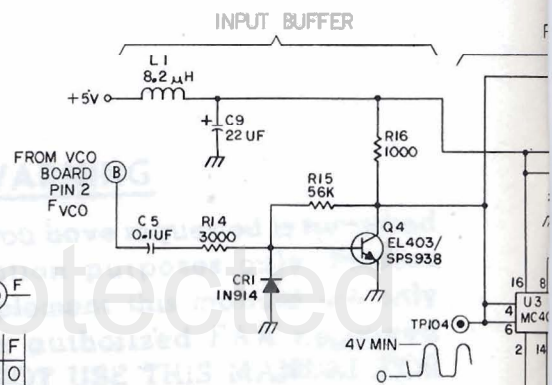
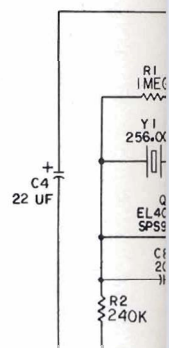
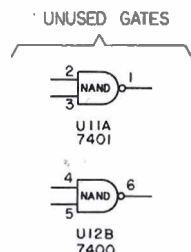


CLOCK - OFFSET BOARD



REGULATOR - DETECTOR BOARD

TYPICAL PIN ARRANGEMENT
FOR ALL TO-92 TRANSISTORS

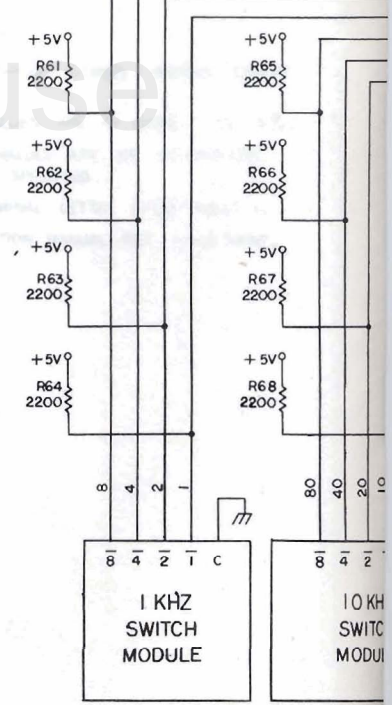


A	B	F
0	0	0
1	0	0
0	1	0
1	1	1

A	B	F
0	0	1
1	0	1
0	1	1
1	1	0

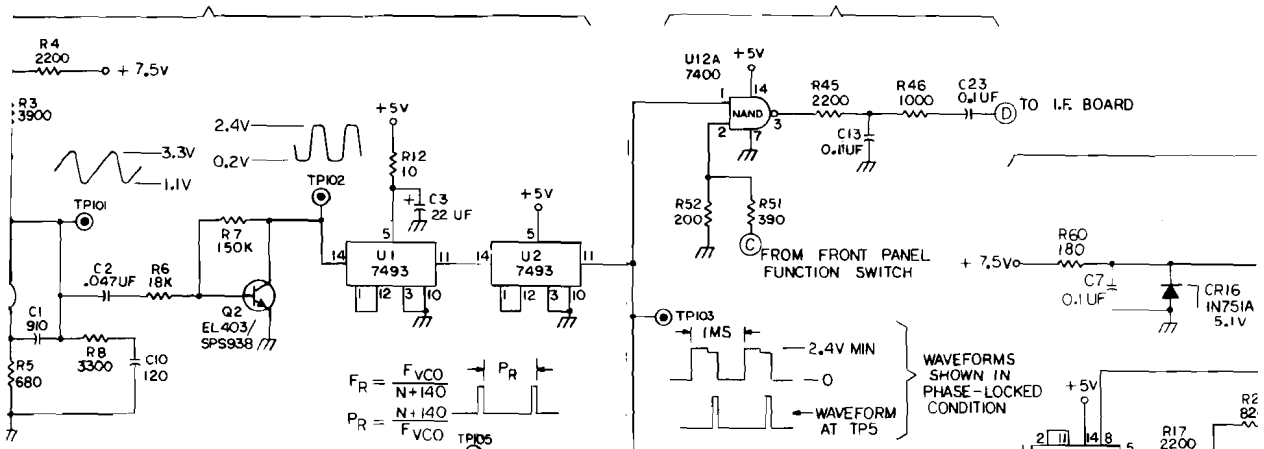
A	B	F
0	0	1
1	0	0
0	1	0
1	1	0

TRUTH TABLES



1.000 KHZ CLOCK

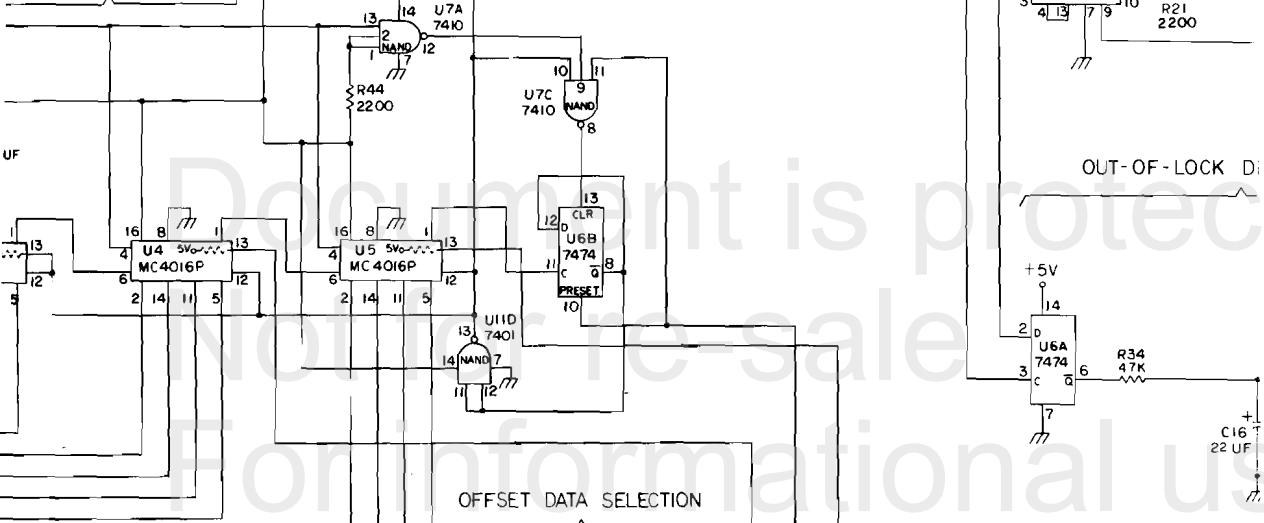
BFO SWITCH



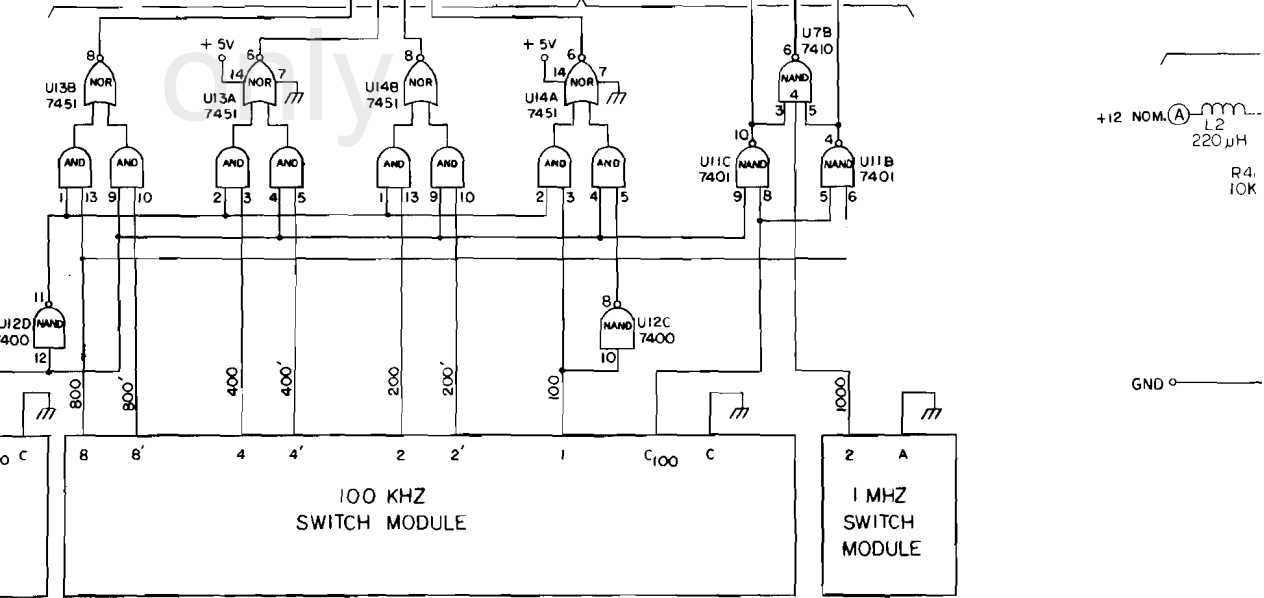
$$F_R = \frac{F_{VCO}}{N+140}$$

$$P_R = \frac{N+140}{F_{VCO}}$$

PROGRAMMABLE COUNTERS



OFFSET DATA SELECTION



OUT-OF-LOCK DI

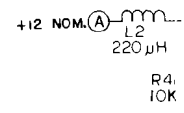
WAVEFORMS SHOWN IN PHASE-LOCKED CONDITION

1MS

2.4V MIN

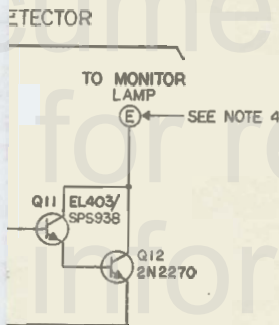
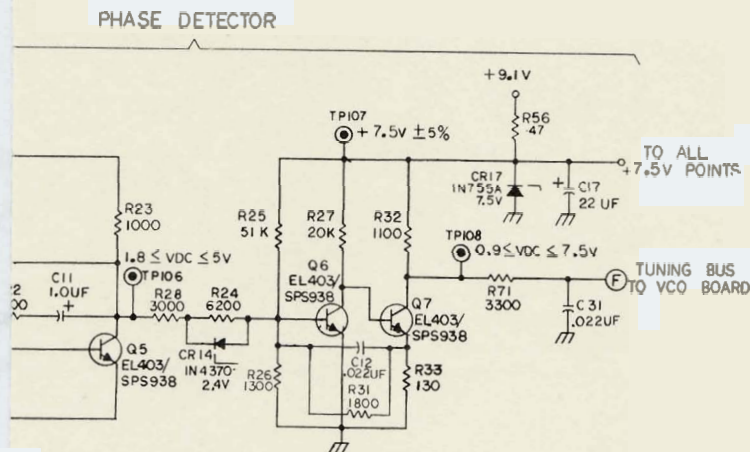
0

WAVEFORM AT TP5



GND

SECTION VI
SCHEMATIC DIAGRAMS

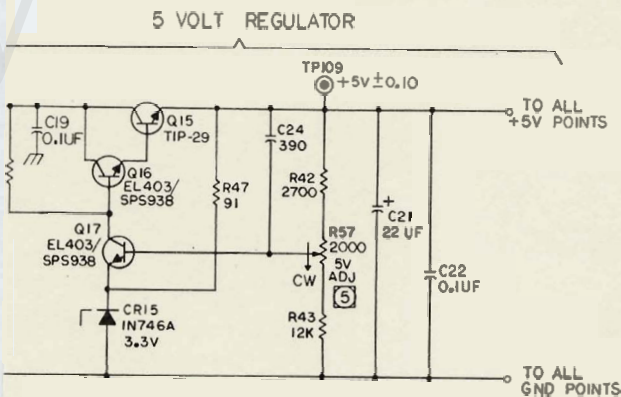


WARNING

This manual which you have requested is furnished for general information purposes only. Service bulletins which supplement this manual are only furnished to Bendix authorized FAA approved repair stations. DO NOT USE THIS MANUAL FOR EFFECTUATING REPAIRS OF THE EQUIPMENT.

NOTES

1. ADD 100 TO ALL CIRCUIT SYMBOL NUMBERS, EXCEPT TEST POINTS.
2. ALL RESISTANCE VALUES ARE IN OHMS, 1/4W, 5%.
3. ALL CAPACITANCE VALUES ARE IN PICOFARADS, UNLESS OTHERWISE SPECIFIED.
4. (E) INDICATES TERMINAL LETTER FROM SHEET 1.
5. REFER TO INSTRUCTION MANUAL FOR ADJUSTMENT.



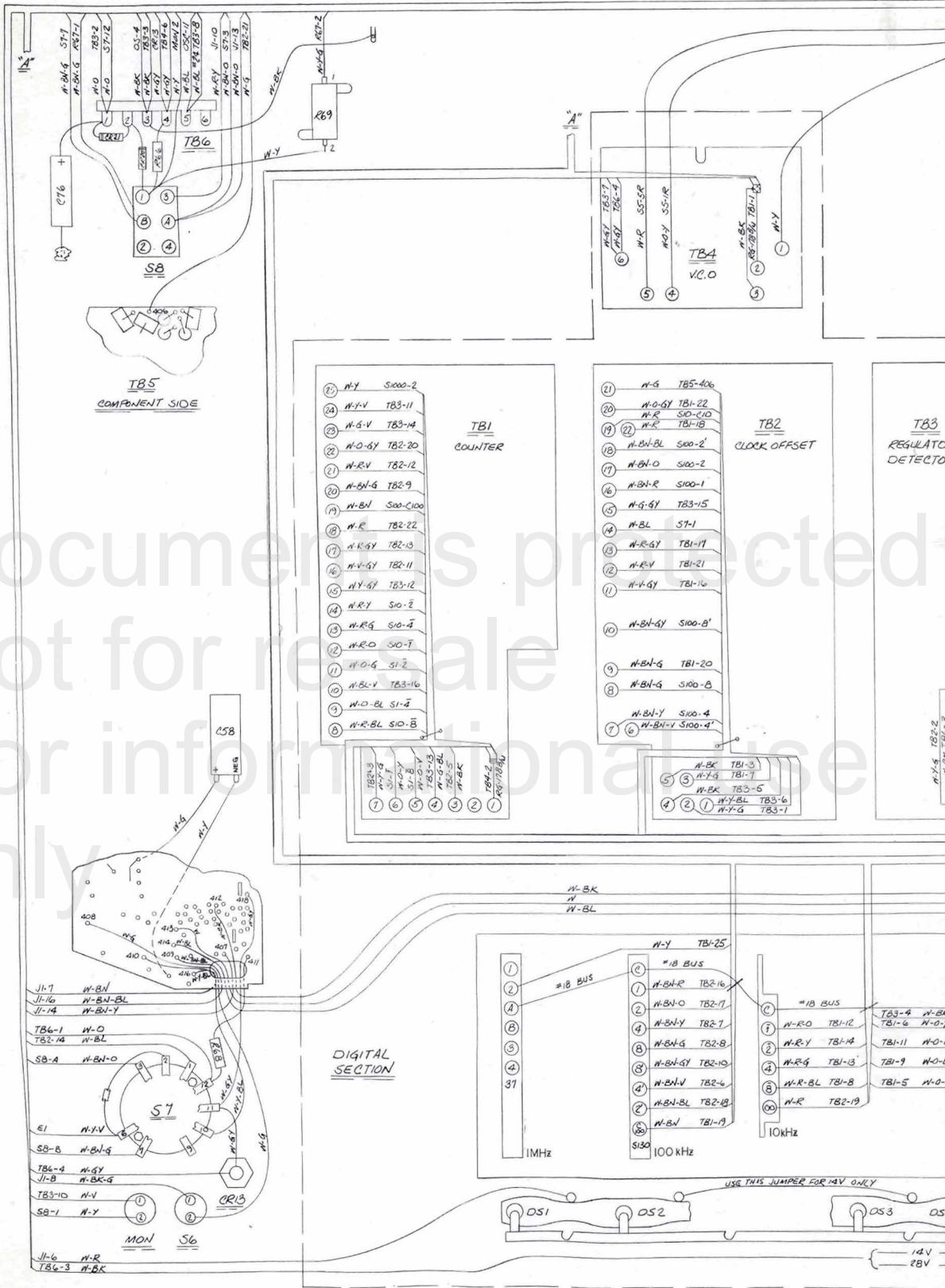
201F ADF Receiver, Schematic Diagram
(Issue H)
Figure 6-1 (Sheet 2 of 2)

SECTION VI
SCHEMATIC DIAGRAMS

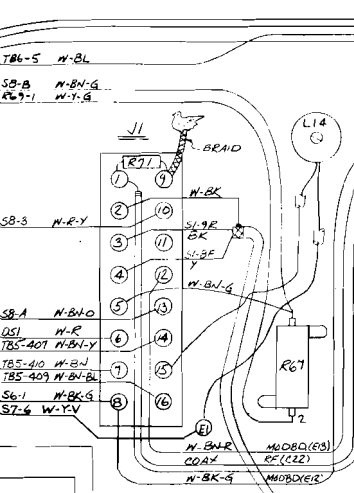
SUMMARY OF CHANGES TO
201F ADF RECEIVER WIRING DIAGRAM

DRAWING ISSUE	DESCRIPTION OF CHANGE	SERVICE BULLETIN NO.	EFFECTIVITY UNIT S/N
A	Changed reference designator on C76 in R-F Module to C78.		1166
	Deleted R68. Changed wiring of S7.		1601
	Deleted CR7, R17, R19 in Mixer Module. Changed reference designator R18 to R17. Changed wiring of C7 in the Loop Module. Changed CR21 to R96 and altered wiring to S8 on TB5.		2850
	Changed wiring of L14.		2883
B	Added C79.		2850
C	Changed reference designator on C78 in R-F Module to C80. Changed reference designator on C69 in Loop Module to C68. Added resistors R20, R21, and R24 between pins 1 and 4 of coils L4, L5 and L6 respectively.		5868
D	Added CR22 and CR23 to J1.		6602

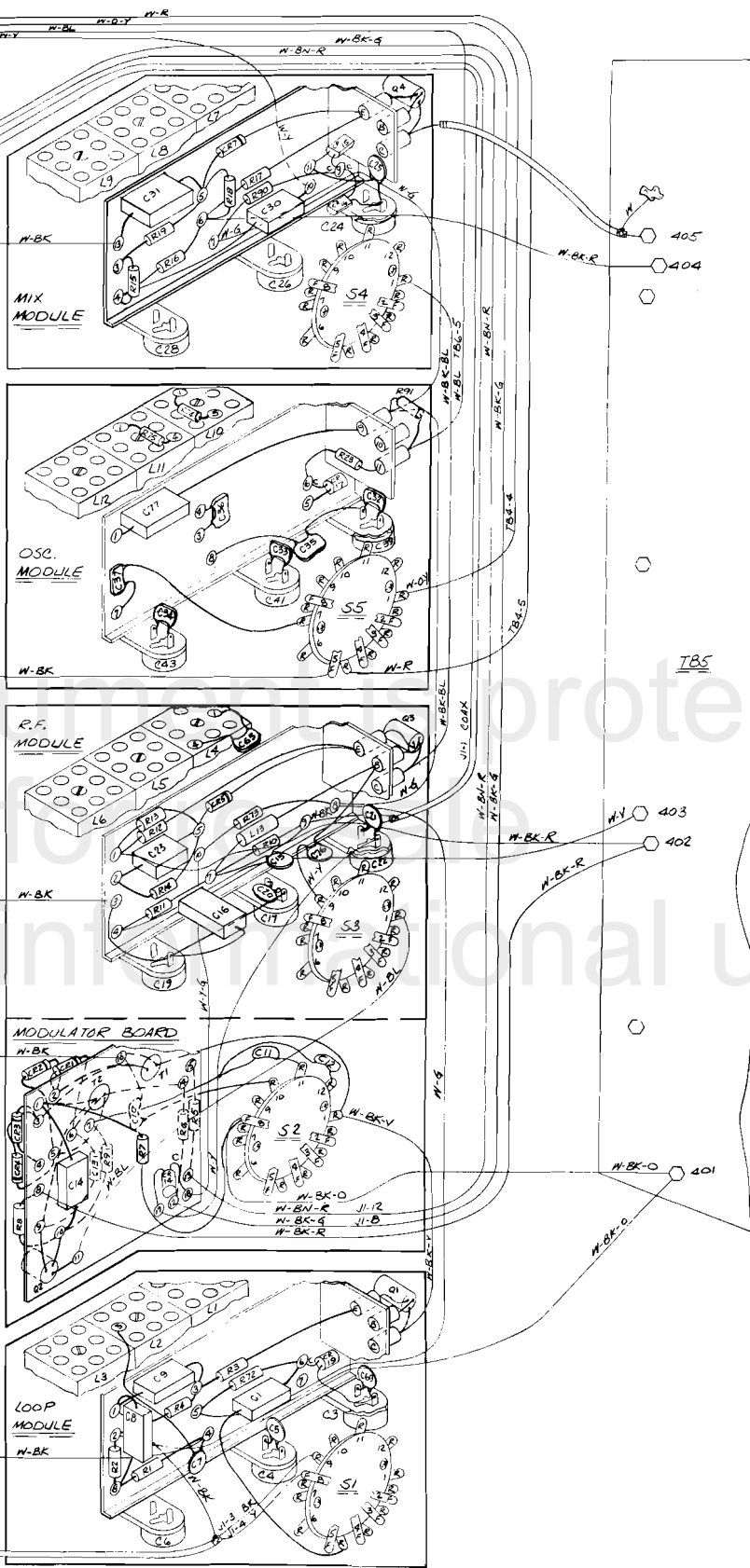
SECTION VI
SCHEMATIC DIAGRAMS



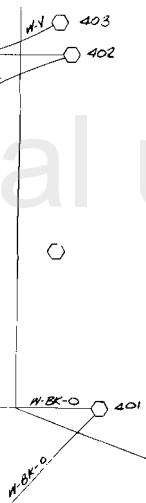
201F ADF Receiver, Wiring Diagram
Figure 6-2



- 1-BL-V (6)
- 1-G-6Y (5)
- 1-G-Y (4)
- 1-G-BL (3)
- 1-X-4Y (2)
- 1-Y-V (1)
- 1-Y (10)
- 1-V (9)
- 1-W-BL (8)

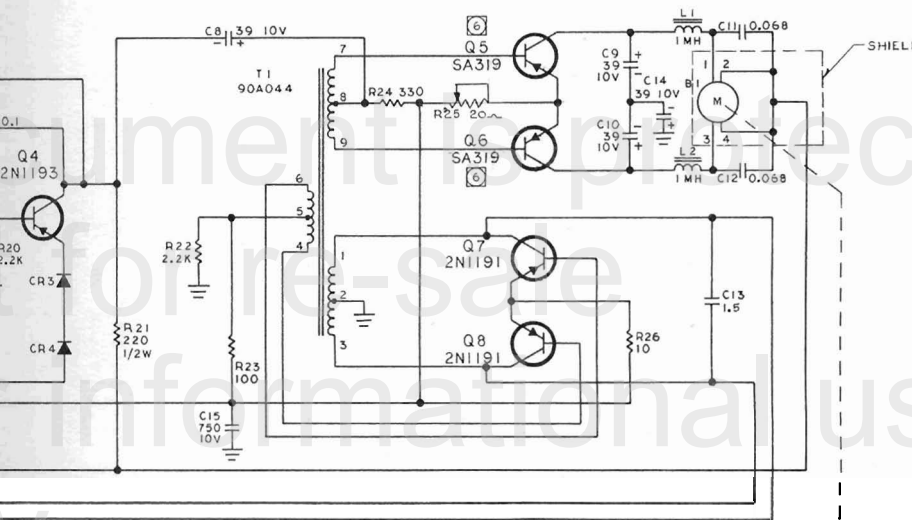


TB5



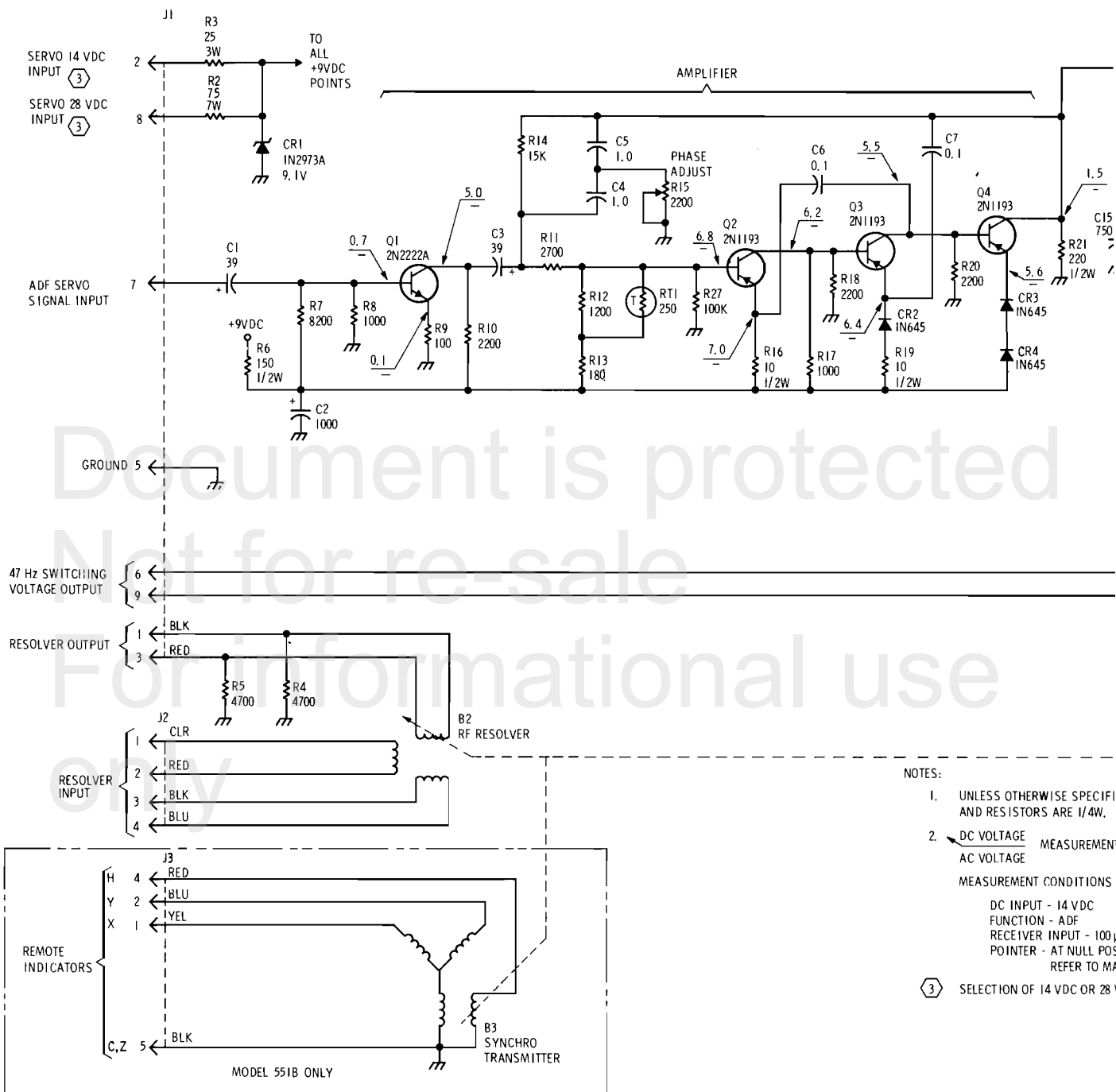
Document protected
Not for
For internal use only

MOTOR CONTROL



OSCILLATOR

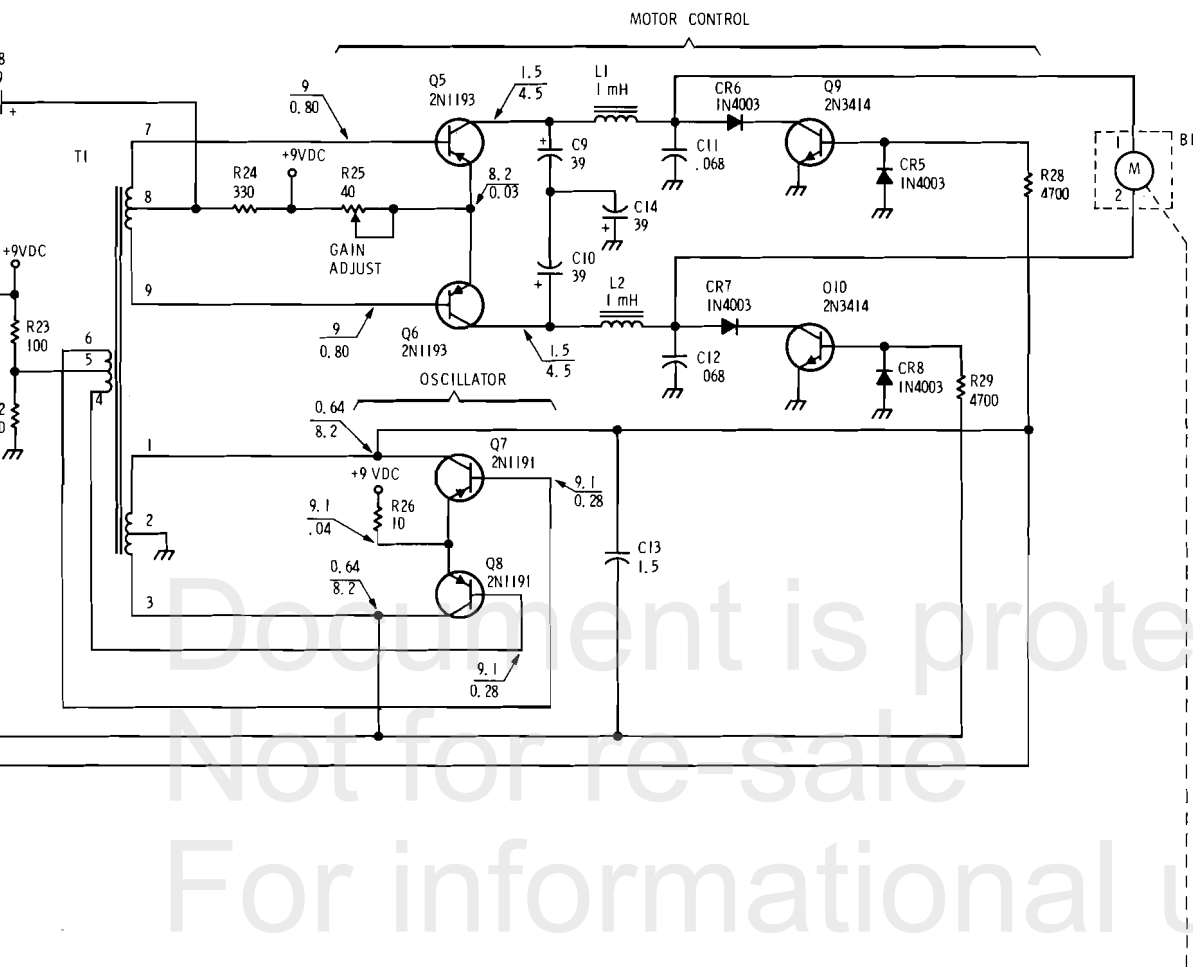
SECTION VI
SCHEMATIC DIAGRAMS



- NOTES:
- UNLESS OTHERWISE SPECIFIED AND RESISTORS ARE 1/4W.
 - DC VOLTAGE MEASUREMENT AC VOLTAGE MEASUREMENT CONDITIONS
DC INPUT - 14 VDC
FUNCTION - ADF
RECEIVER INPUT - 100%
POINTER - AT NULL POS
REFER TO MA
- (3) SELECTION OF 14 VDC OR 28 V

3D065
Z

551A/551B Servo Amplifier-Indicator, Schematic Diagram
(Issue Z)
Figure 6-3



CAPACITANCE IS IN μF , RESISTANCE IS IN OHMS.

MADE WITH A VTVM

AS FOLLOWS:

METER
ON; FOR OFF-NULL CONDITION.
MAINTENANCE SECTION OF MANUAL.

OPERATION IS PERFORMED BY A SWITCH IN THE RECEIVER.

MODEL 551A SERVO AMPLIFIER INDICATOR:
FOR INSTRUMENT PANEL MOUNTING.

MODEL 551B REMOTE SERVO AMPLIFIER:
FOR REMOTE MOUNTING.

MAY BE USED TO DRIVE INSTRUMENT
PANEL MOUNTED INDICATORS.

SECTION VI
SCHEMATIC DIAGRAMS

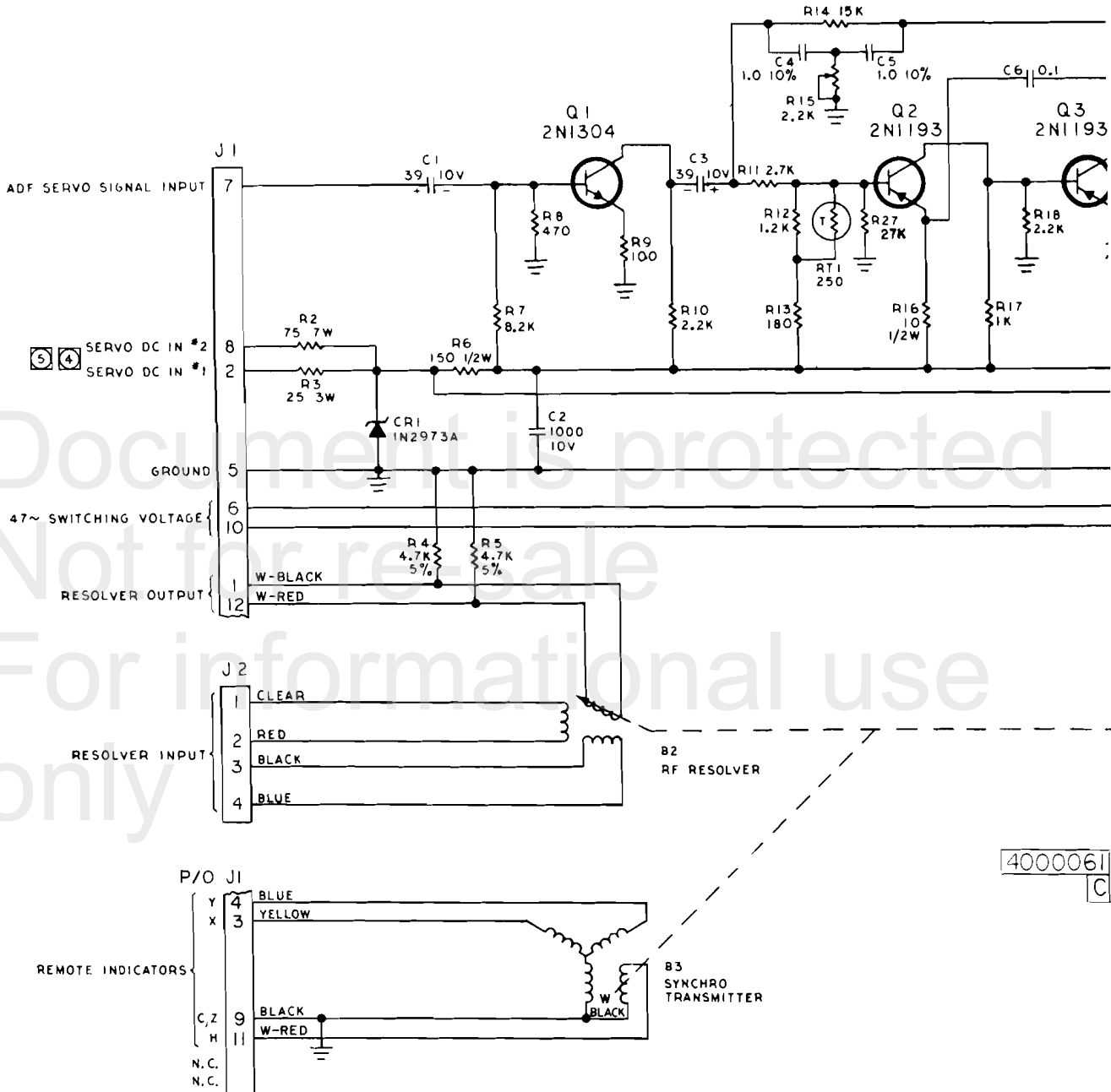
SUMMARY OF CHANGES TO
551E SERVO AMPLIFIER-INDICATOR, SCHEMATIC DIAGRAM
DRAWING NO. 4000061

SCHEMATIC ISSUE	DESCRIPTION OF CHANGE	SERVICE BULLETIN NO.	EFFECTIVITY UNIT S/N
A thru C	Changes made prior to release.		
D	Transistors Q9, Q10 and associated switching circuitry added for new type motor (B1).	T12- 008- 1	3741
E	Changed reference designator of 4700 ohm resistor from R27 to R29. Changed value of C2 from 1 K to 1000. Change to correct drawing errors only.		N/A
F	Changed Q5 and Q6 from SA319 to 2N1193. Matched Pair (SA319) not needed with new type motor (B1).		3741
G	Changed value of R25 from 20 ohms to 40 ohms to increase adjustment range.	T12- 015	3804
H	Changed value of R8 from 470 ohms to 1000 ohms. Changed type number of Q1 from 2N1304 to 2N2222A. Changes made to improve high temperature operation.	T12- 016	3812
J	Illustration redrawn.	-	-

Part of Figure 6-5

SECTION VI
SCHEMATIC DIAGRAM

AMPLIFIER



④ THE VOLTAGE CHANGE FROM 14V TO 28V OPERATION IS ACCOMPLISHED BY A SWITCH IN THE RECEIVER.

3. CR2, CR3 & CR4 ARE BENDIX P/N 512005-01.

2. ALL CAPACITANCE VALUES ARE IN MICROFARADS.

1. ALL RESISTANCE VALUES ARE IN OHMS, $\pm 10\%$, $1/4W$.

⑥ Q5 & Q6 (SA319) ARE USED AND REPLACED AS MATCHED PAIR ONLY.

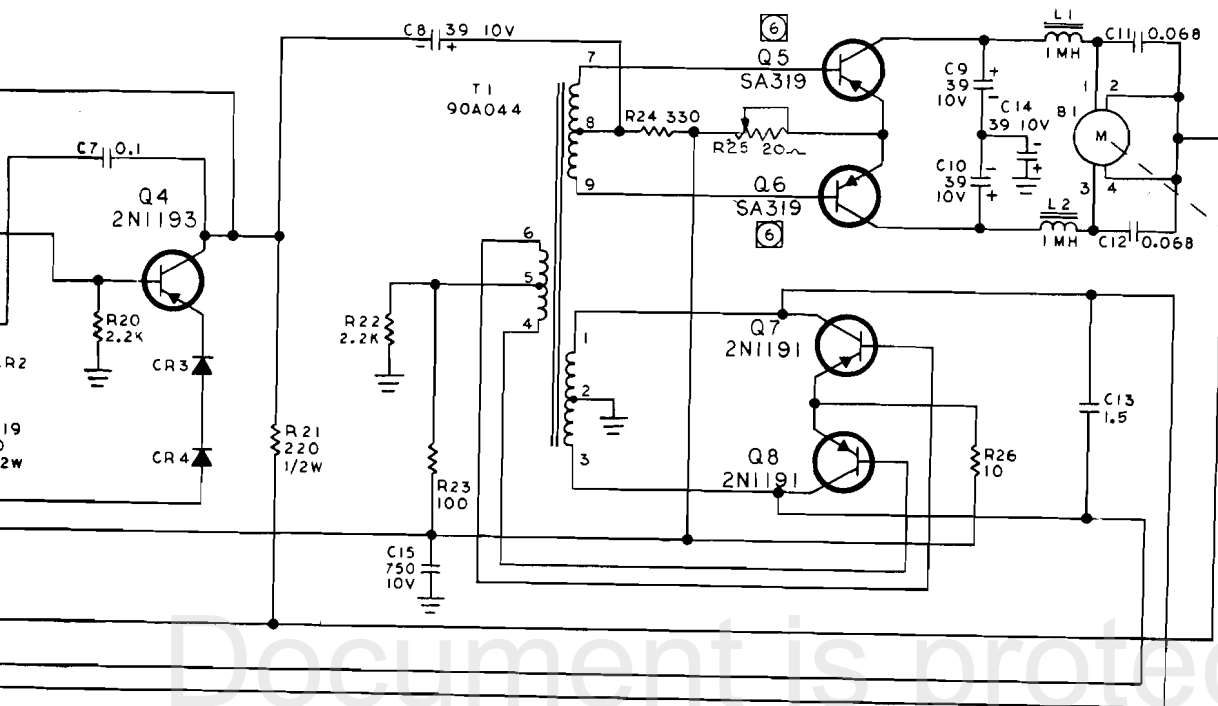
⑤ FOR EMERGENCY OPERATION THIS UNIT MAY BE CONNECTED TO EXTERNAL DRY CELL BATTERIES.

⑦ S R

551E Servo Amplifier-Indicator, Schematic Diagram
Diagram (Issues A through C)

Figure 6-5

MOTOR CONTROL

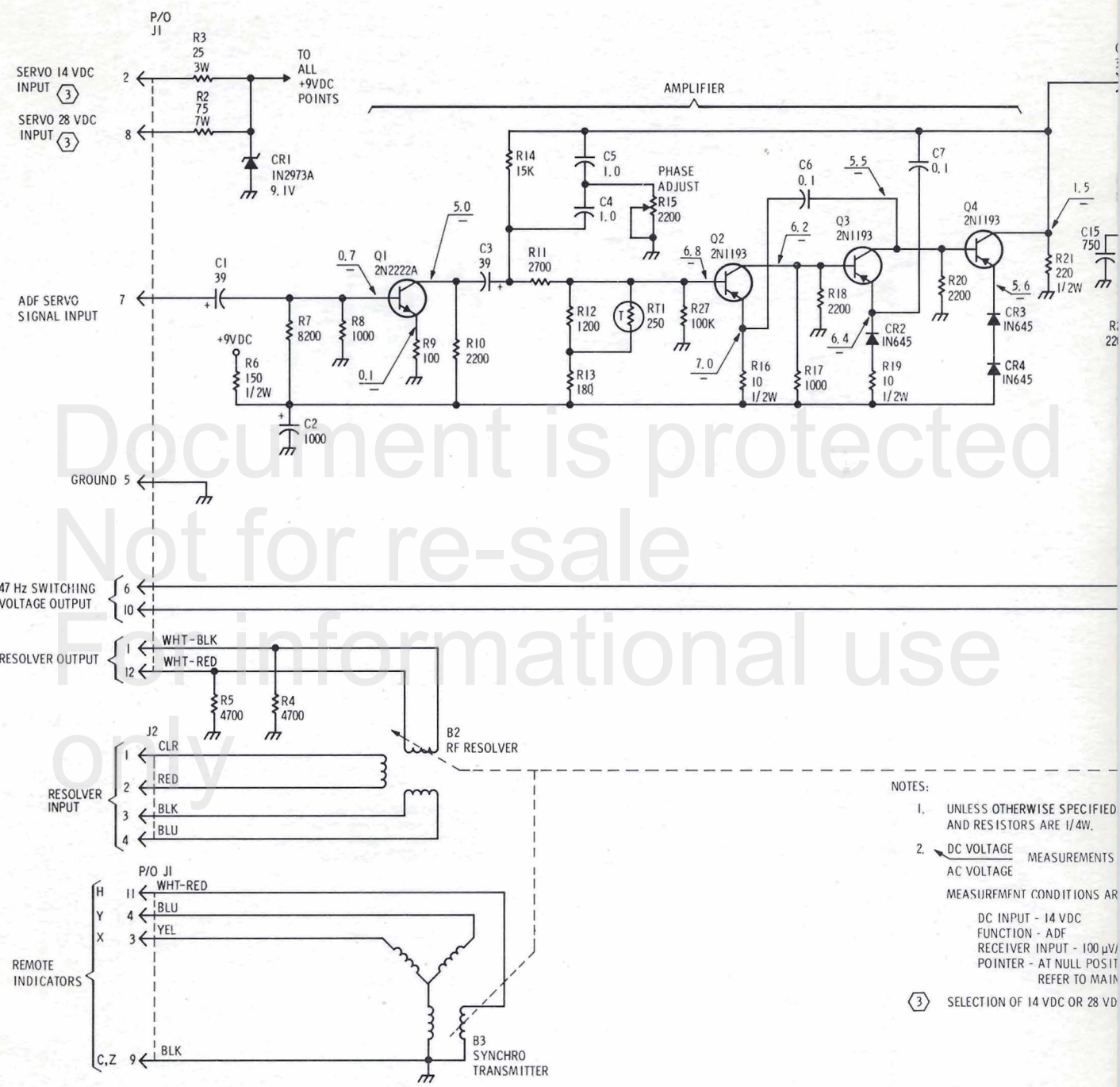


OSCILLATOR

WARNING

This manual which you have requested is furnished for general information purposes only. Service bulletins which supplement this manual are only furnished to Bendix authorized FAA approved repair stations. DO NOT USE THIS MANUAL FOR EFFECTUATING REPAIRS OF THE EQUIPMENT.

SECTION VI
SCHEMATIC DIAGRAMS

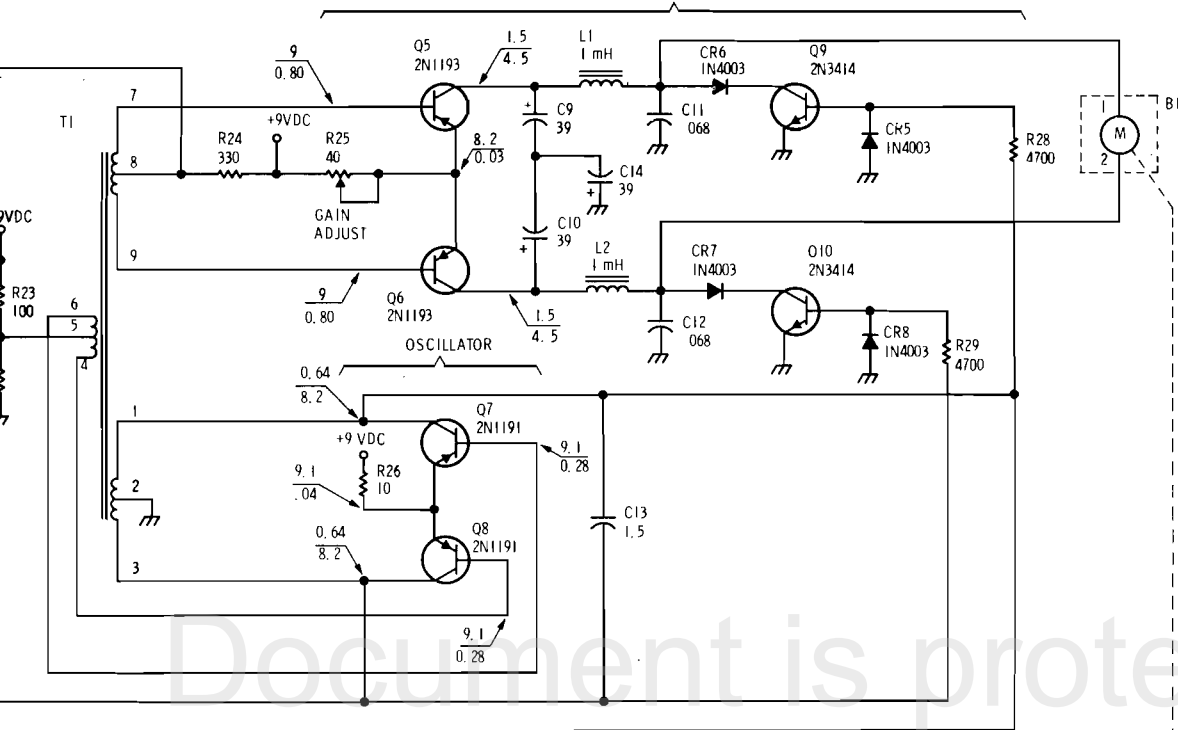


- NOTES:
1. UNLESS OTHERWISE SPECIFIED AND RESISTORS ARE 1/4W.
 2. DC VOLTAGE MEASUREMENTS
AC VOLTAGE MEASUREMENTS
- MEASUREMENT CONDITIONS ARE:
DC INPUT - 14 VDC
FUNCTION - ADF
RECEIVER INPUT - 100 μV/
POINTER - AT NULL POSIT
REFER TO MAIN
- ③ SELECTION OF 14 VDC OR 28 VDC

4000061
J

551E Servo Amplifier-Indicator, Schematic Diagram
(Issue J)
Figure 6-5

MOTOR CONTROL



CAPACITANCE IS IN μF , RESISTANCE IS IN OHMS,

MEASURE WITH A VTVM

AS FOLLOWS:

OPERATION IS PERFORMED BY A SWITCH IN THE RECEIVER.

MODEL 551E REMOTE SERVO AMPLIFIER:
FOR INSTRUMENT PANEL MOUNTING.
MAY BE USED TO DRIVE INSTRUMENT
PANEL MOUNTED INDICATORS.

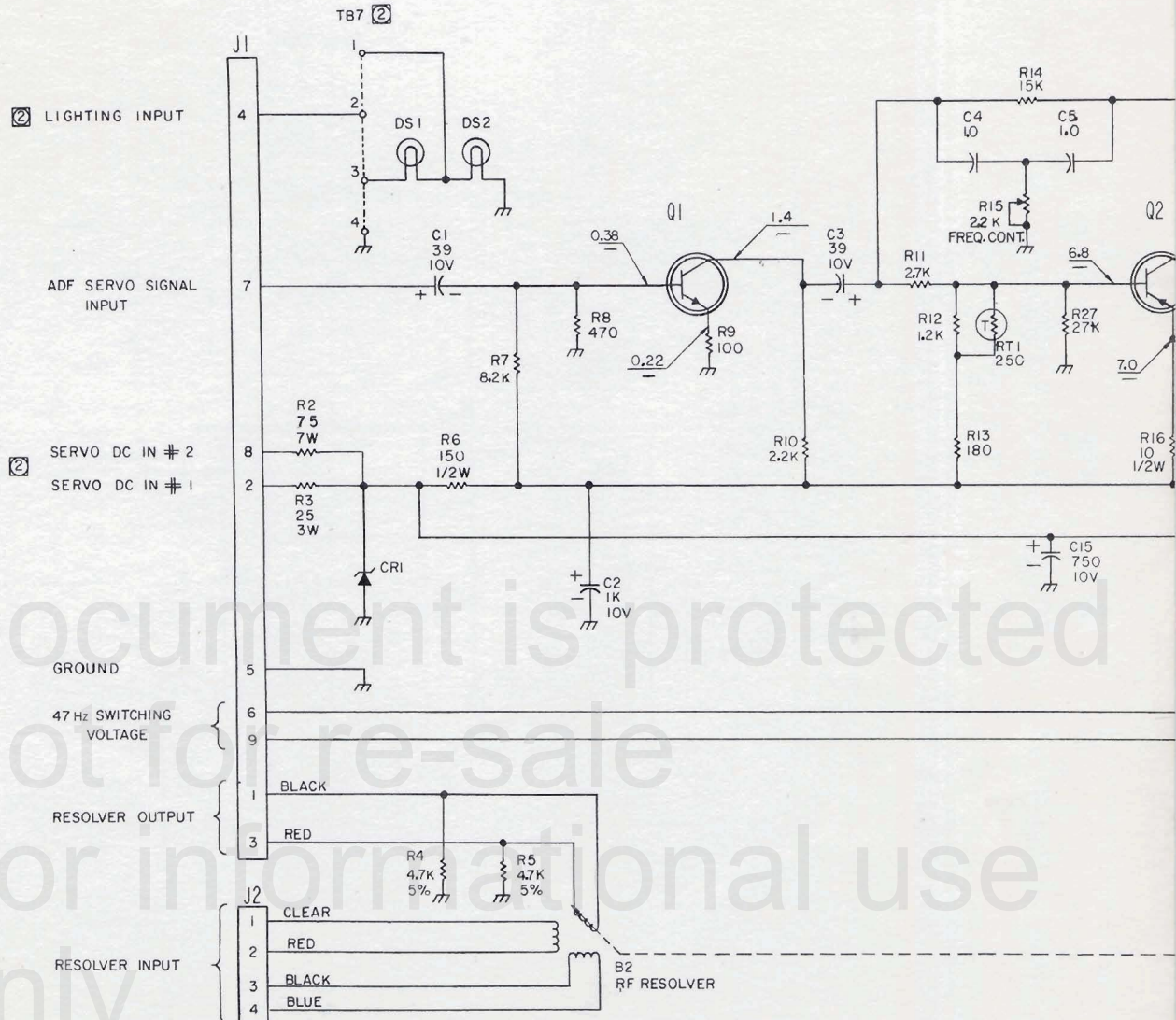
Document is protected
Not for re-sale
For informational use
only

SECTION VI
SCHEMATIC DIAGRAMS

SUMMARY OF CHANGES TO
551RL SERVO AMPLIFIER-INDICATOR, SCHEMATIC DIAGRAM
DRAWING NO. 4000243

SCHEMATIC ISSUE	DESCRIPTION OF CHANGE	SERVICE BULLETIN NO.	EFFECTIVITY UNIT S/N
B	Transistors Q9, Q10 and associated switching circuitry added for new type motor (B1).	T12- 008-	2674
C	Changed reference designator of 4700 ohm resistor R27 to R29. Changed value of C2 from 1K to 1000. Changes made to correct drawing errors.	1	N/A
D	Changed Q5 and Q6 from SA319 to 2N1193. Matched pair (SA319) not needed with new type motor (B1).		2674
E	Changed value of R25 from 20 ohms to 40 ohms to increase adjustment range.	T12- 015	5171
F	Changed value of R8 from 470 ohms to 1000 ohms. Changed type number of Q1 from 2N1304 to 2N2222A. Changes made to improve high temperature operation.	T12- 016	5445
G	Illustration redrawn.		

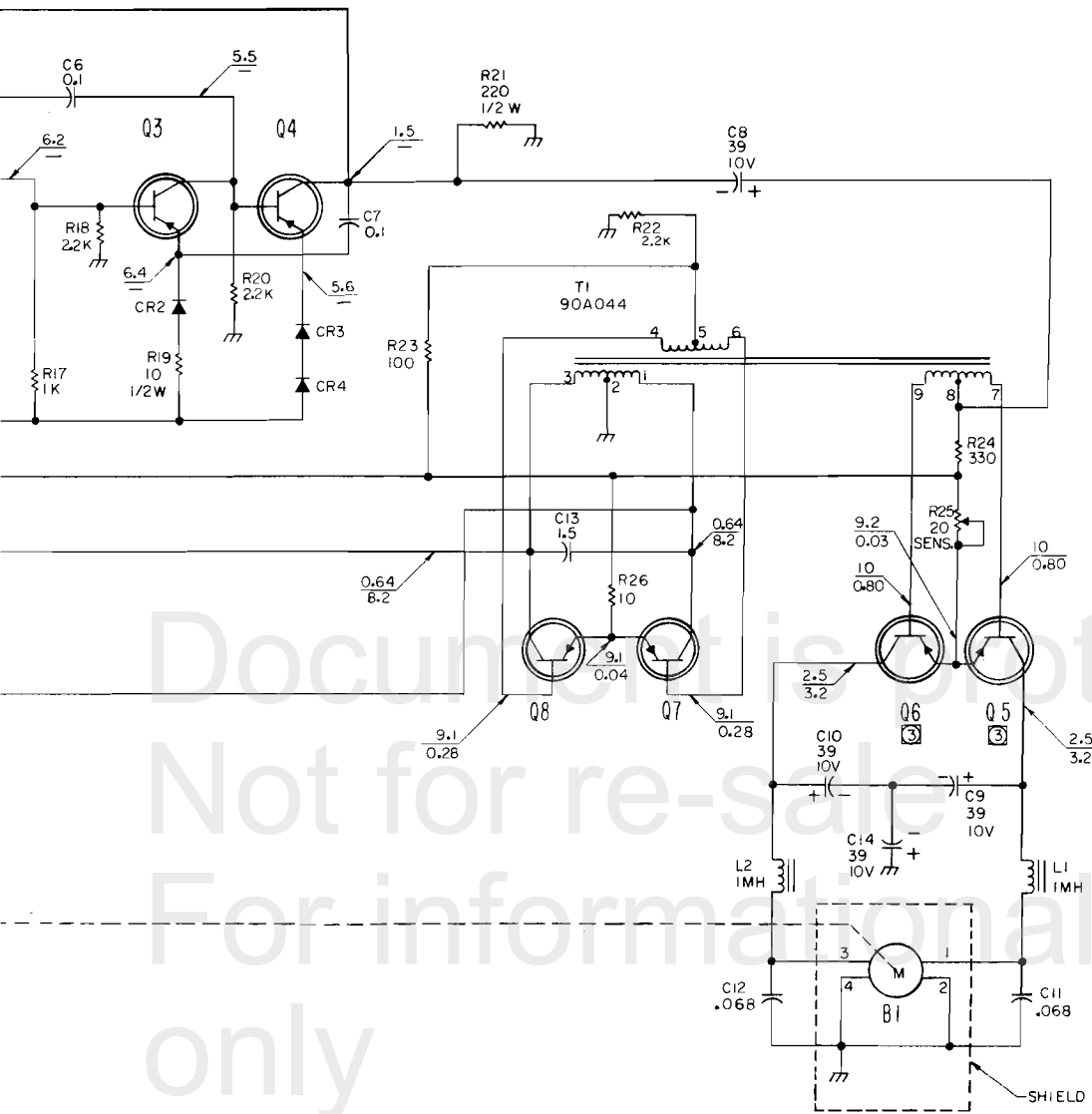
SECTION VI
SCHEMATIC DIAGRAM



NOTES

1. EXCEPT WHERE NOTED ALL RESISTANCE VALUES ARE IN OHMS, $\pm 10\%$, 1/4 W, K=1000, AND ALL CAPACITANCE VALUES ARE IN MICROFARADS.
2. THE 14/28 VOLT CONVERSION IS MADE INTERNALLY FOR THE LIGHTING, AND EXTERNALLY WITH A SWITCH IN THE REC FOR 14V LIGHTING, JUMPER PINS 1+2 AND PINS 3+4 OF TB7 FOR 28V LIGHTING, JUMPER PINS 2+3 OF TB7
3. Q5 & Q6 ARE USED AND REPLACED AS MATCHED PAIR ONLY.
4. DC VOLTAGE MEASUREMENTS MADE WITH A VTVM
 AC VOLTAGE
 MEASUREMENT CONDITIONS:
 DC INPUT-14VDC
 FUNCTION-ADF
 RECEIVER INPUT-100 μ V/METER
 POINTER-AT NULL POSITION; FOR OFF-NULL CONDITION REFER TO MAINTENANCE SECTION OF

551RL Servo Amplifier-Indicator, Schematic Diagram
(Issue A)
Figure 6-6

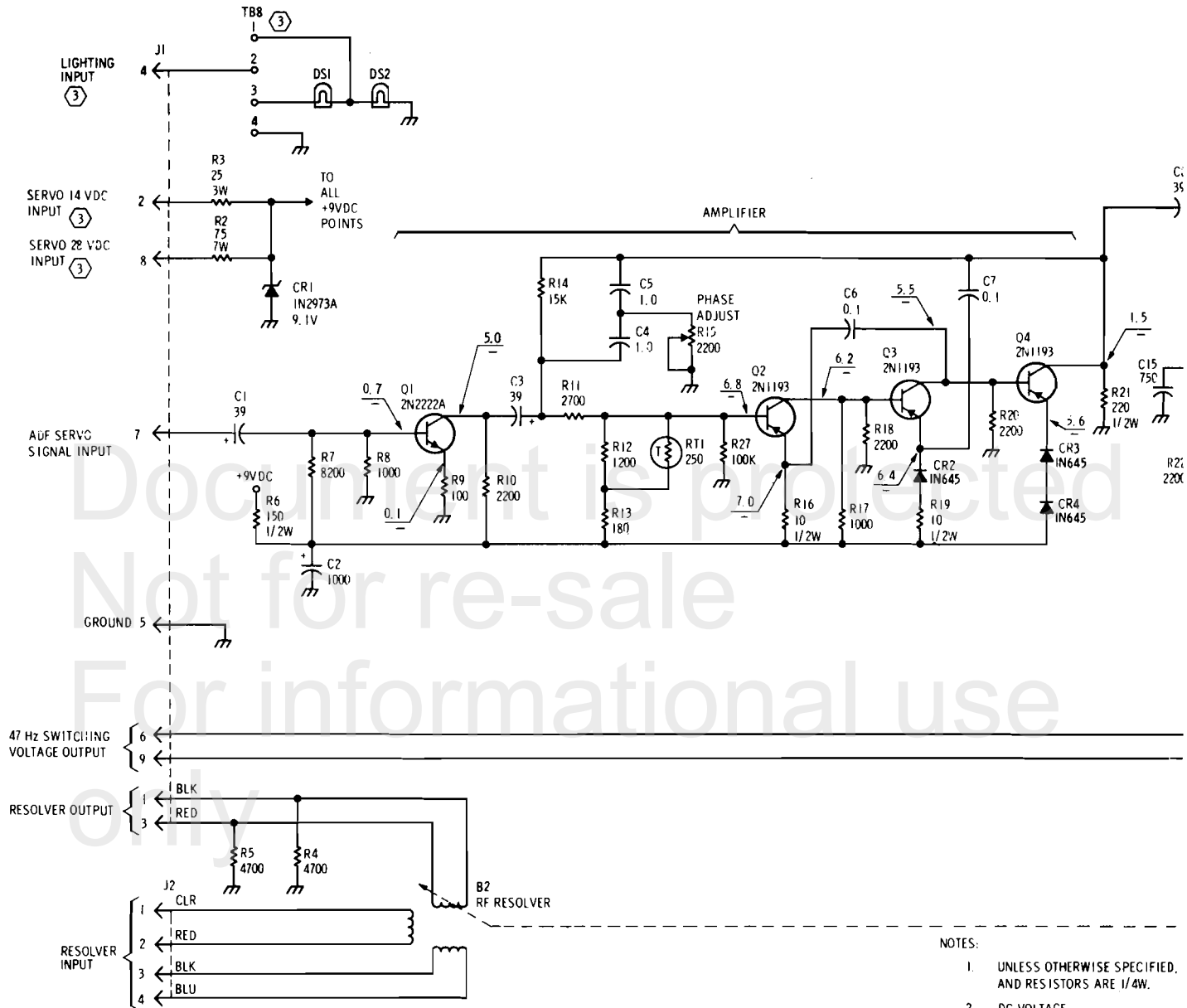


Document is protected
 Not for re-sale
 For informational use
 only

FOR THE CIRCUITRY.

MANUAL.

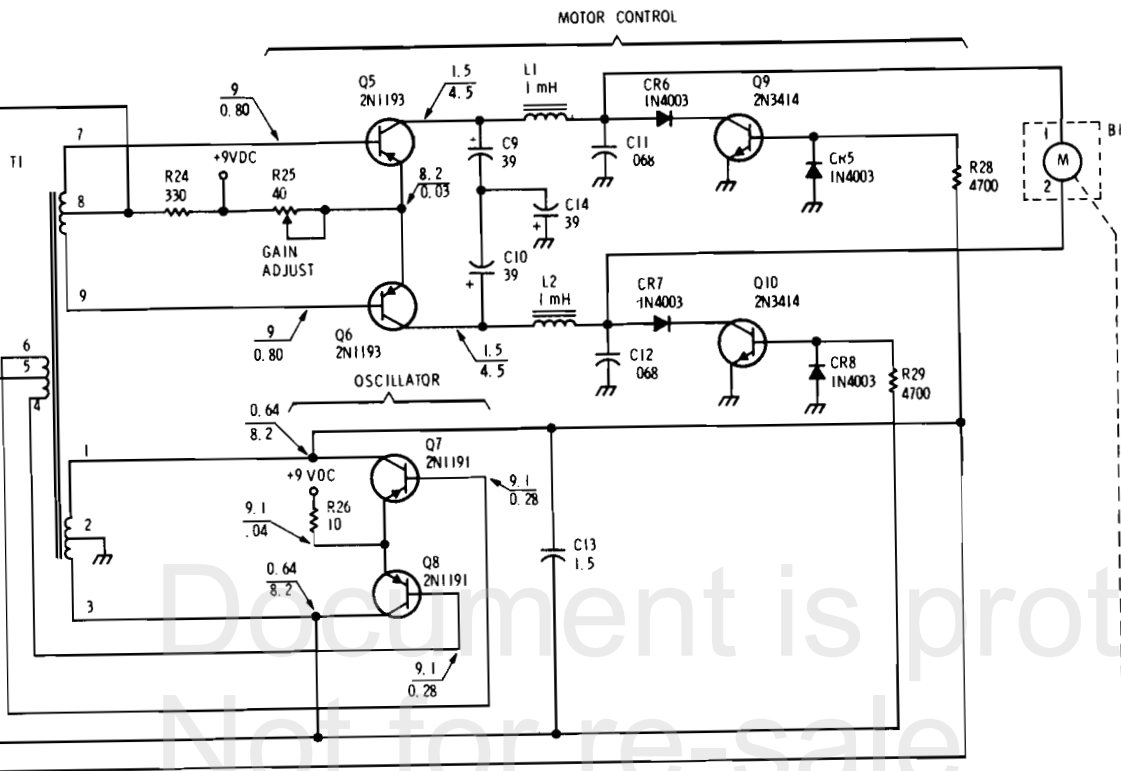
SECTION VI
SCHEMATIC DIAGRAMS



- NOTES:
- UNLESS OTHERWISE SPECIFIED, AND RESISTORS ARE 1/4W.
 - DC VOLTAGE MEASUREMENTS MADE AT NULL POSITION. AC VOLTAGE MEASUREMENTS MADE AT NULL POSITION. REFER TO MAINT.
- MEASUREMENT CONDITIONS ARE:
DC INPUT - 14 VDC
FUNCTION - ADF
RECEIVER INPUT - 100 μV/V
POINTER - AT NULL POSITION
REFER TO MAINT.
- (3) SELECTION OF 14 VDC OR 28 VDC EXCEPT FOR LIGHTING. FOR 14VDC LIGHTING, JUMPER P PIN 1 TO PIN 2 AND PIN 3 TO PIN 4. FOR 28VDC LIGHTING, JUMPER P PIN 1 TO PIN 2 AND PIN 3 TO PIN 4.

4000243
G

551RL Servo Amplifier-Indicator, Schematic Diagram
(Issue G)
Figure 6-6



CAPACITANCE IS IN μF . RESISTANCE IS IN OHMS.

WITH A VTVM

FOLLOWS:

FOR OFF-NULL CONDITION.
SEE SECTION OF MANUAL.

ADJUSTMENT IS PERFORMED BY A SWITCH IN THE RECEIVER.

CONNECT T88 AS FOLLOWS:

4.
CONNECT T88 PIN 2 TO T88 PIN 3.

WARNING

This manual which you have requested is furnished for general information purposes only. Service bulletins which supplement this manual are only furnished to Bendix authorized FAA approved repair stations. DO NOT USE THIS MANUAL FOR EFFECTUATING REPAIRS OF THE EQUIPMENT.

Document is protected
Not for re-sale
For informational use
only

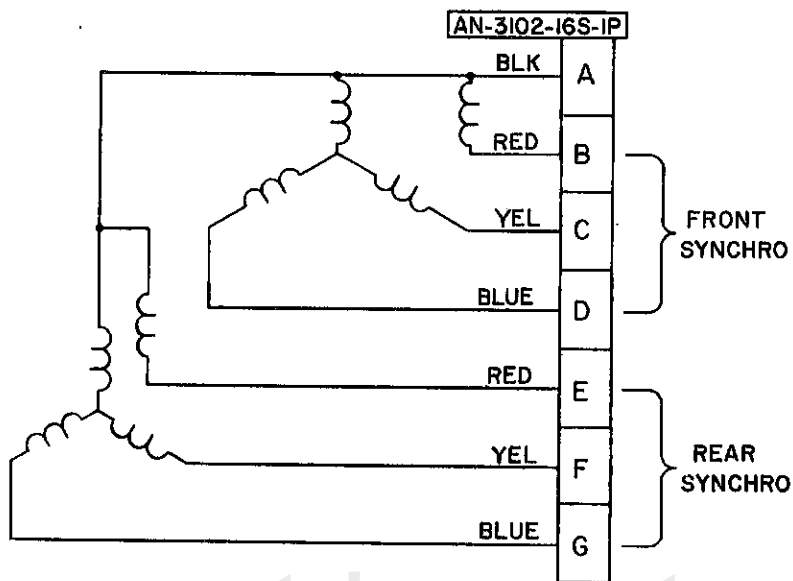
SECTION VI
SCHEMATIC DIAGRAMS

SUMMARY OF CHANGES TO
551A/551B SERVO AMPLIFIER-INDICATOR, SCHEMATIC DIAGRAM
DRAWING NO. 3D065

SCHEMATIC ISSUE	DESCRIPTION OF CHANGE	SERVICE BULLETIN NO.	EFFECTIVITY UNIT S/N
A thru T	Changes made prior to release.		
U	Transistors Q9, Q10 and associated switching circuitry added for new type motor (B1).	T12- 008- 1	28127
V	Changed reference designator of 4700 ohm resistor from R27 to R29. Changed value of C2 from 1 K to 1000. Change to correct drawing errors only.		N/A
W	Changed Q5 and Q6 from SA319 to 2N1193. Matched pair (SA319) not needed with new type motor (B1).		28127
X	Changed value of R25 from 20 ohms to 40 ohms to increase adjustment range.	T12- 015	31581
Y	Changed value of R8 from 470 ohms to 1000 ohms. Changed type number of Q1 from 2N1304 to 2N2222A. Changes made to improve high temperature operation.	T12- 016	31778
Z	Illustration redrawn.	-	-

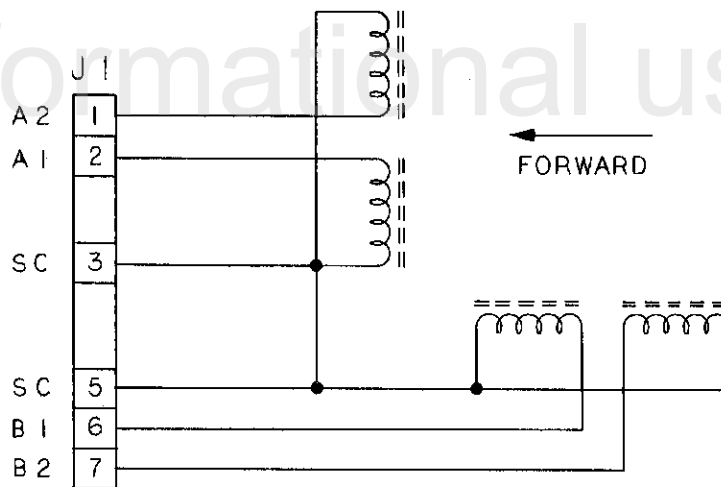
Document is protected
Not for re-sale
For informational use
only

SECTION VI
SCHEMATIC DIAGRAM



705658
A

551C Dual Synchro Indicator, Schematic Diagram
Figure 6-7



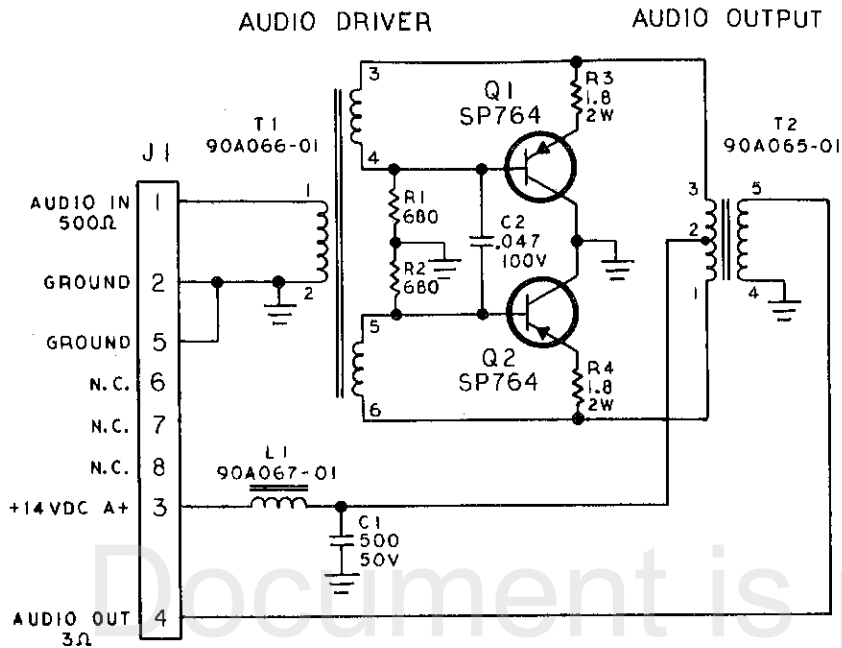
CONNECTOR

(PIN NOS. 1-7 CW FROM
BOTTOM OF LOOP)

3B716164
C

2321E Loop Antenna, Schematic Diagram
Figure 6-8

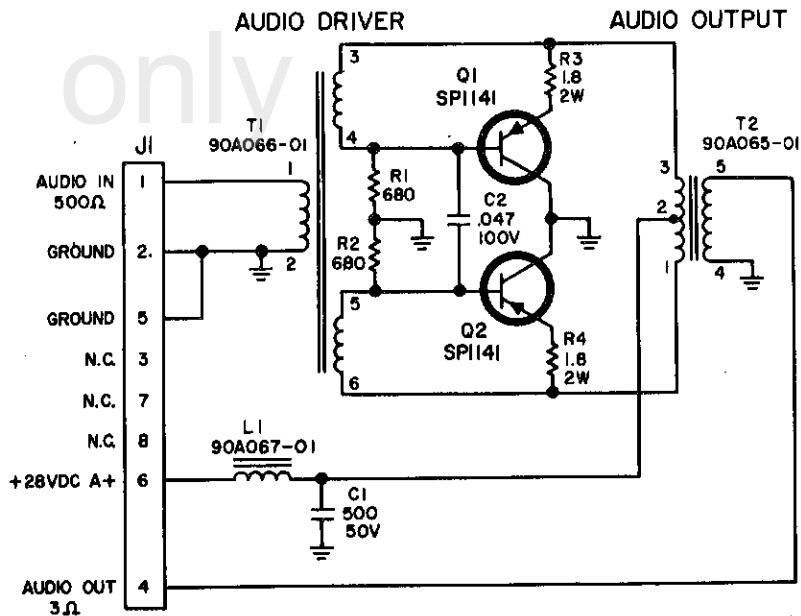
SECTION VI
SCHEMATIC DIAGRAM



- NOTES:
1. ALL RESISTANCE VALUES ARE IN OHMS, $\pm 10\%$, 1/2W. UNLESS OTHERWISE SPECIFIED.
 2. ALL CAPACITANCE VALUES ARE IN MICROFARADS, UNLESS OTHERWISE SPECIFIED.

3B092
A

102A Audio Amplifier, Schematic Diagram
Figure 6-9



- NOTES:
1. ALL RESISTANCE VALUES ARE IN OHMS, $\pm 10\%$, 1/2W. UNLESS OTHERWISE SPECIFIED.
 2. ALL CAPACITANCE VALUES ARE IN MICROFARADS, UNLESS OTHERWISE SPECIFIED.

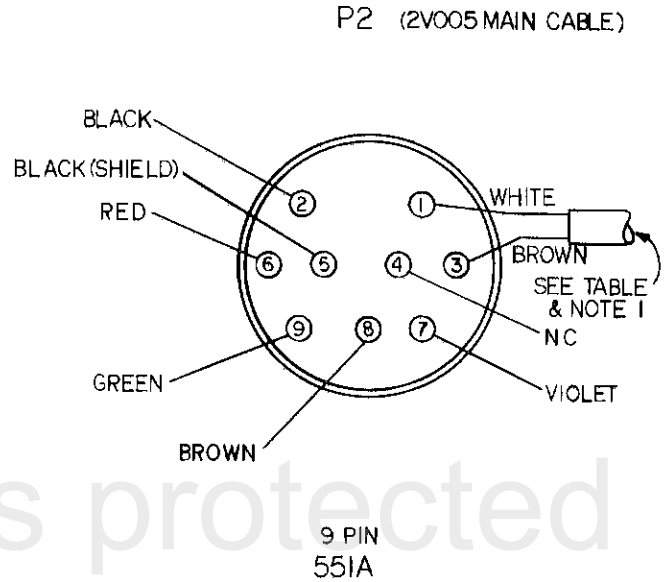
3B264

102B Audio Amplifier, Schematic Diagram
Figure 6-10

SECTION VI
SCHEMATIC DIAGRAM

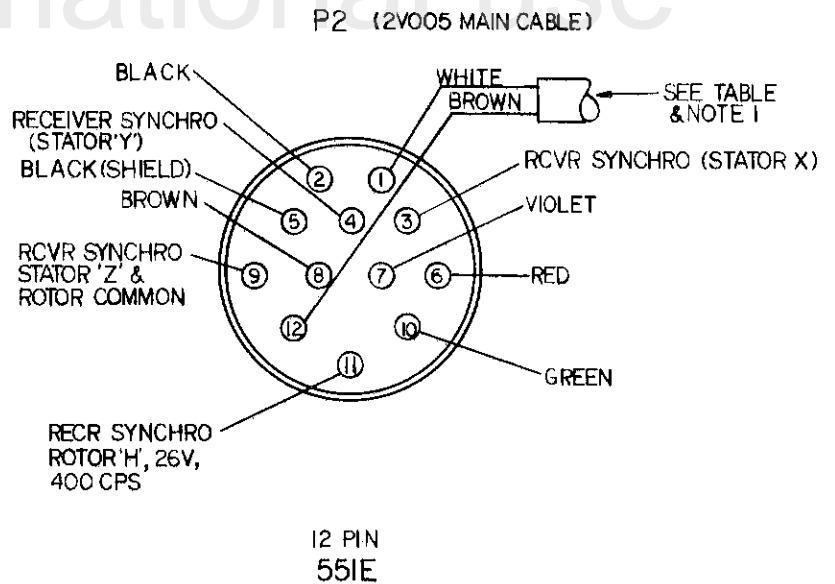
TABLE I
COAX COLOR CAN BE AS FOLLOWS

PIN 1	PIN 3	PIN 12
WHITE	BROWN	BROWN
GOLD	SILVER	SILVER
GREEN	YELLOW	YELLOW
WHITE	BLACK	BLACK



Document is protected
Not for re-sale
For informational use
only

NOTES:
I. REVERSE CONNECTIONS FOR BOTTOM MOUNTED SENSE ANTENNA.



2071610
A

551() Indicator (Connector Field Modification), Wiring Diagram
Figure 6-11

Document is protected
Not for re-sale
For informational use
only