

**Aircraft
Systems, Inc.**

ACCESSORY OVERHAUL

F.A.A. STATION KC2R947K

GREATER ROCKFORD AIRPORT

5187 FALCON ROAD • ROCKFORD, ILLINOIS 61109 • PHONE (815) 399-0225 • FAX (815) 399-0084

FAX TRANSMISSION

TO : _____
ATTENTION: JEFF STEFFAN F 304-254-9740
FROM : TERRY F. NORRIS
DATE : MAY-5-2015
PAGE 1 of 3

JEFF :

PLEASE FIND WIRING SCHEMATIC
FOR BARON SYNCHRONIZER SYSTEM.

★
→ USE CAUTION & DON'T
GO INTO OR PROBE THE SOCKET
WITH A SPADE TERMINAL LARGER
THAN 0.040 THICK BY 0.140 WIDE.

BEST REGARDS :

Terry

PN 5438-218
 FUSE & RESISTOR
 Pin 8 TO 7. 23-27-Ω

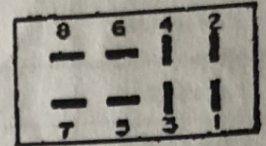

SOCKET FACE

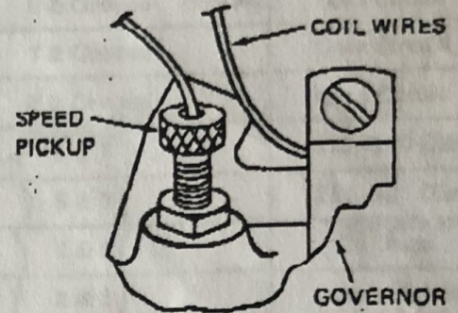
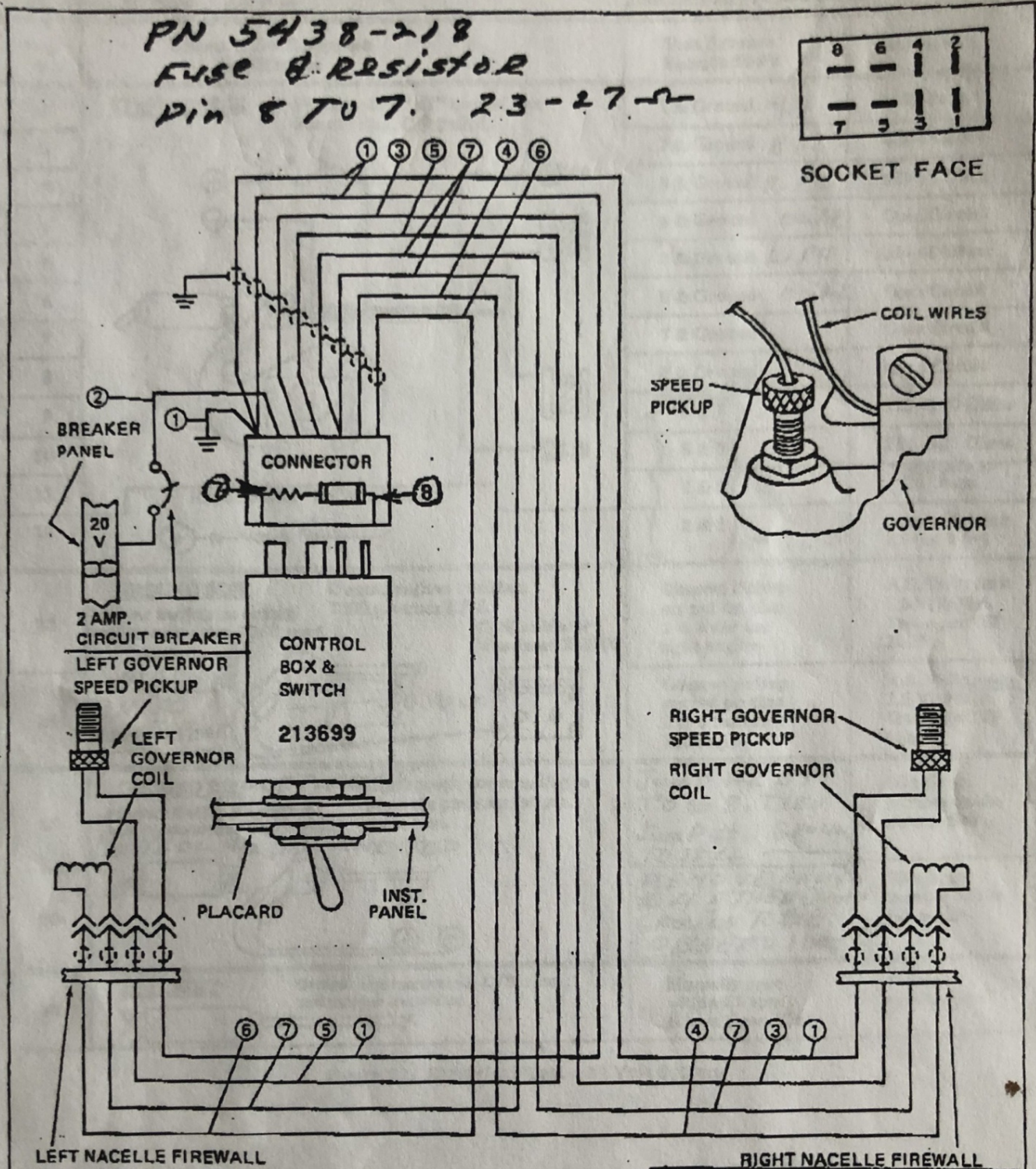

CAUTION

TO ENSURE THAT THERE IS NO DAMAGE TO JONES PLUG RECEPTACLES, OHMMETER PROBES SHOULD HAVE A DIAMETER NO GREATER THAN 0.045 INCH.

ACCESSORY OVERHAUL
Aircraft Systems, Inc.
815-399-0225
 5187 FALCON RD. ROCKFORD, ILL. 61109

Figure 20. Typical System Wiring Diagram



Use Ohmmeter on X1 or X10 Scale		Resistance May Be 10% Higher After Heat Soak	
Test #	System & Test Equipment Configuration	Test Between Receptacle #'s	Required
1	<p>STATIC CHECK Master switch "off" control box disconnected, C/B pulled.</p> 	1 & Ground $\frac{1}{11}$	0 Ohms
2		2 & Ground B+	Open Circuit
3		3 & Ground R. P4	52 - 68 Ohms
4		4 & Ground coil R	Open Circuit
5		5 & Ground L. P4	52 - 68 Ohms
6		6 & Ground coil L	Open Circuit
7		7 & Ground	Open Circuit
8		8 & Ground	Open Circuit
9		1 & 7	110 - 140 Ohms
10		6 & 7	110 - 140 Ohms
11		7 & 8	25 Ohms
12		2 & 1	Supply Voltage 2 (+) & 1 (-)
13	<p>GROUND RUN Operate engines to obtain 2000 governor RPM.</p> <p>Master Switch on control box disconnected, C/B reset</p> <p>Oscilloscope or Woodward 213599</p> 	Observe Pickup output on pins 1 & 3 for the right engine	A.C. Volts peak 1.5 V. @ Min. Cruise per TSP 1555
14	<p>3.0 V AC PEAK TO PEAK</p> <p>3.0 VOLT.</p> 	Observe pickup output on pins 1 & 5 for the left engine	A.C. Volts peak 1.5 V. @ Min. Cruise per TSP 1555
15	<p>GROUND RUN - OR FLIGHT High enough power setting to be on the governors at min. cruise rpm.</p> <p>Master Switch on control box disconnected, C/B reset</p> <p>CONTROL BOX DISCONNECTED</p> 	JUMP #2 B+ TO # 8. THEN JUMP # 1 GROUND TO # 4	50 ± 5 rpm increase on the right engine
16		REMOVE FROM # 4 & THEN JUMP GROUND TO # 6. OBSERVING	50 ± 5 rpm increase on the left engine
17	<p>IN FLIGHT Control box connected, C/B reset and master switch on</p> 	Manually sync within 15 rpm & turn Sync "On"	Propellers synchronized

Figure 21. Electrical Test - 24 Volt System

Baron
Prop Synch

Need $\frac{1}{4}$ amp fuse

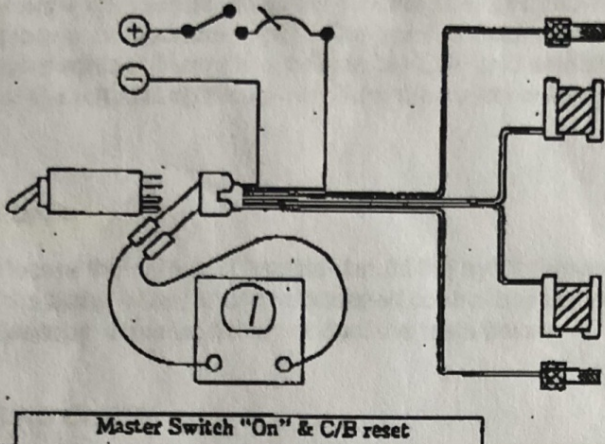
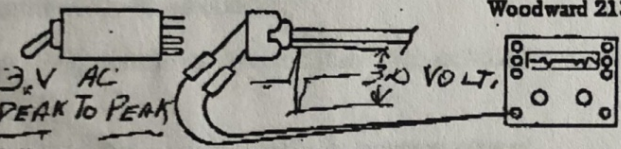
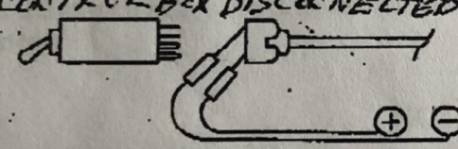
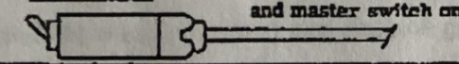

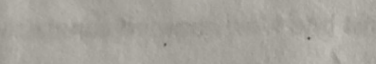
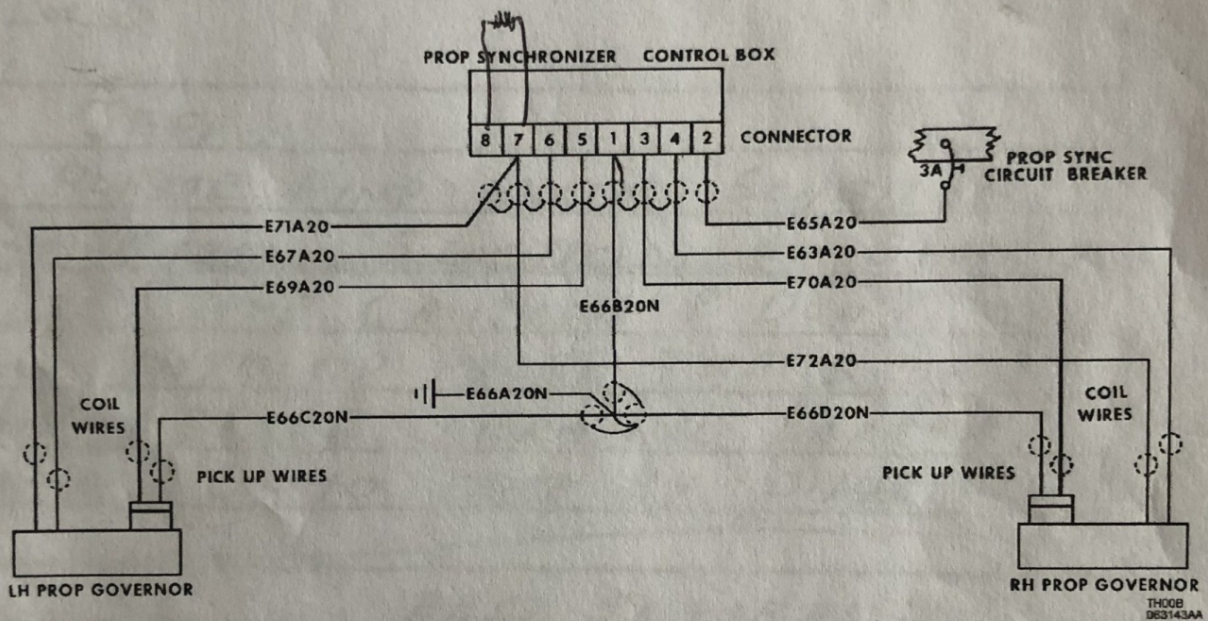
TC-1710 thru TC-1935 except TC-1913; TE-981 thru TE-1063;
TH-467 thru TH-647 except TH-473, TH-474 and TH-598

Terry Norris @ Aircraft Systems, Inc. (815) 399-0225

Socket - no more than .040" wide

Raytheon Aircraft

BEECH BARON 55 AND 58 SHOP MANUAL

SYNCHRONIZER FUNCTIONAL TEST

Proper operation of the propeller synchronizer can be determined by the following method. Manually adjust the propeller control levers to equal rpm. Turn the propeller synchronizer ON. Slowly adjust, in small increments, either propeller governor to increase or decrease rpm. The rpm should remain synchronized over a limited range predetermined by the synchronizer. Turn the synchronizer OFF and establish a maximum of 25 rpm difference between the engine rpm of the left and right engines. Turn the synchronizer ON and the rpm of both engines should synchronize.

SYNCHRONIZER CHECKS

These checks will help locate the source of trouble should the synchronizer system malfunction. If no malfunctions are found among the units being tested, the transistorized control box is probably the source of trouble. An ohmmeter, voltmeter and oscilloscope are required to conduct the tests below.

SYNCHRONIZER WIRING CHECK

- a. To eliminate the most obvious causes for malfunction make sure that the airplane battery master switch is ON, that the propeller synchronizer circuit breaker is not tripped, and that the modified Jones plug receptacle is properly mated with the plug in the airplane electrical system.
- b. Unplug the control box, turn the airplane master switch OFF, and pull the propeller synchronizer circuit breaker before proceeding further with these checks.
- c. Complete the following resistance checks: (See Figure 7-2A.)

CAUTION

Zero the ohmmeter and read on the X1 or X10 scale during the following checks. Do not use a probe greater than 0.045 inch in thickness. Insert and remove the probe carefully to avoid damaging the pin connectors.

NOTE

Readings may be 20 percent higher during heat soak following engine shutdown.

1. Check the resistance between pin 1 and airplane ground. The ohmmeter should indicate 0 ohms. 0.1
2. Check the resistance between pin 2 and airplane ground. The ohmmeter should indicate an open circuit. ✓ 28 volts
3. Check the resistance between pin 3 and airplane ground. The ohmmeter should indicate 52 - 68 ohms. 58.5
4. Check the resistance between pin 4 and airplane ground. The ohmmeter should indicate an open circuit. 270 ohms
5. Check the resistance between pin 5 and airplane ground. The ohmmeter should indicate 52 - 68 ohms. 59.0
6. Check the resistance between pin 6 and airplane ground. The ohmmeter should indicate an open circuit. 10.3 ohms
7. Check the resistance between pin 7 and airplane ground. The ohmmeter should indicate an open circuit. 139.1 ohms
8. Check the resistance between pins 4 and 7. The ohmmeter should indicate 112 - 138 ohms. 129.7

Raytheon Aircraft

BEECH BARON 55 AND 58 SHOP MANUAL

9. Check the resistance between pins 6 and 7. The ohmmeter should indicate 112 - 138 ohms. *129.2 ohms*
10. Check the resistance between pins 7 and 8. The ohmmeter should indicate 23 - 27 ohms. The plug incorporates a resistor and a fuse between these pins. *27 ohms*
- d. Turn the airplane battery master switch ON, and reset the propeller synchronizer circuit breaker, but leave the control box unplugged.
- e. Using the dc voltmeter, check that the voltage between pin receptacles 1 and 2 is the same as the supply voltage, and the polarity of pin number 1 is negative while that of pin number 2 is positive.
- f. Using an oscilloscope, check the voltage between pins 5 and 1, and 3 and 1. With the engine operating at cruise rpm, the oscilloscope should indicate 3.0 volts, peak to peak. The voltage should not read less than 2.0 peak to peak, at minimum cruise rpm nor more than 10.0 volts, peak to peak, at maximum cruise rpm.

NOTE

These readings are based on a magnetic pickup/toothed wheel clearance gap of approximately 0.005 inch. If adjustment is required, refer to the Woodward Test Specification SP-197 for adjustment procedures.

- g. When the system is in compliance with the preceding check values, plug the control box into the synchronizer system and flight check.

FLIGHT CHECK

- a. Check the effect of rpm and/or power setting, particularly in the lower cruise range on synchronizer action. If operation at lower rpm results in improved synchronization, inspect the drives to the governors.
- b. Reduce the electrical load and turn off the generator and all other electrical units, except the master switch and synchronizer. If synchronizing improves, abnormal voltage spikes on the airplane bus from some other electrical accessory may have been upsetting the synchronizer. Isolate the offending accessory and repair it. If the trouble lies in the control box, replace it.

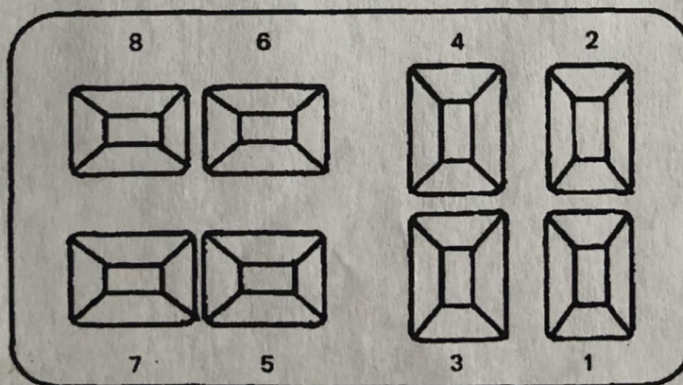

VIEW OF CONTROL BOX CONNECTOR
SHOWING NUMBERED TERMINALS

58P-351-2

Synchronizer Plug
Figure 7-2A