

Beechcraft SERVICE INSTRUCTIONS

CLASS II

55

No. 0614-351
ATA Code 24-30

SUBJECT: ELECTRICAL - NOSE SECTION - REMOVAL OF S550 KLIPVOLT SUPPRESSOR FROM BATTERY MASTER RELAY AND INSTALLATION OF 1N4005 DIODE

EFFECTIVITY: BEECHCRAFT Baron 95-B55 and 95-B55A, serials TC-763 through TC-1204, 95-C55, 95-C55A, D55 and D55A, serials TC-350, TE-1 through TE-674.

REASON: To reduce the possibility of wiring damage should the suppressor malfunction.

COMPLIANCE: As soon as possible after receipt of these service instructions, but no later than the next scheduled inspection.

DESCRIPTION: The existing S550 Klipvolt suppressor, wire P57A18 and wire P58A18 should be removed and an 1N4005 diode installed.

APPROVAL: FAA Approved - DOA CE-2.

MANPOWER: The following information is for planning purposes only:

Estimated man-hours: 1 hour.
Suggested number of men: 1 man.

MATERIAL: The 1N4005 diode and Military Standard, MIL-I-631, sleeving may be obtained locally.

SPECIAL TOOLS: None.

WEIGHT AND BALANCE: None.

REFERENCES: None.

PUBLICATIONS AFFECTED: It is recommended that a note be made on the applicable figure in all Baron Parts Catalog copies to, "See Service Instructions No. 0614-351". The same note should be added to the applicable wiring diagrams of all Baron Shop Manual copies.

ACCOMPLISHMENT INSTRUCTIONS: This modification may be accomplished in the following manner:

1. Gain access to the battery master relay and S550 Klipvolt suppressor through the right hand baggage compartment door. The battery master relay and S550 Klipvolt suppressor are located aft of the baggage compartment door on the support structure.

WARNING

Disconnect the battery connectors, disconnect the external power source and ensure that all electrical power is off.

NO BECP

1 of 2

Operation, care and maintenance of the airplane is the owners responsibility. As conditions warrant BEECH AIRCRAFT CORPORATION issues service instructions, recommending modifications and operational procedures to enable the owner to get the maximum utility and safety from his airplane. These instructions are available to BEECHCRAFT owners through their BEECHCRAFT Distributor or Dealer. An index of Service Instructions is issued periodically. When instructions are issued, a temporary recording of the publication should be made in the appropriate index. Warranty reimbursement will be considered on specific items so noted in the service instruction provided the airplane is within the first six month period after delivery from the Factory and meets the terms and conditions defined in the published standard BEECHCRAFT warranty. Requests for warranty consideration on items so noted must be received within the time limits noted in the service instructions.

Service Instructions No. 0614-351

2. Use Military Standard, MIL-I-631, sleeving to insulate the 1N4005 diode leads. Butt the sleeving against the diode and leave approximately 1/4 inch at the end of each lead bare.
3. Remove the S550 Klipvolt suppressor lead P58A18 from the battery master relay terminal and connect the 1N4005 diode lead, at the banded end of the diode, in its place.
4. Remove wire P57A18 and connect the remaining lead of the 1N4005 diode in its place. Remove the S550 Klipvolt suppressor and leads. (Refer to the illustration for wiring diagram.)
5. Reconnect the battery connectors and secure the nose baggage compartment door.

RECORD COMPLIANCE: Upon completion of these service instructions, make an appropriate maintenance record entry.

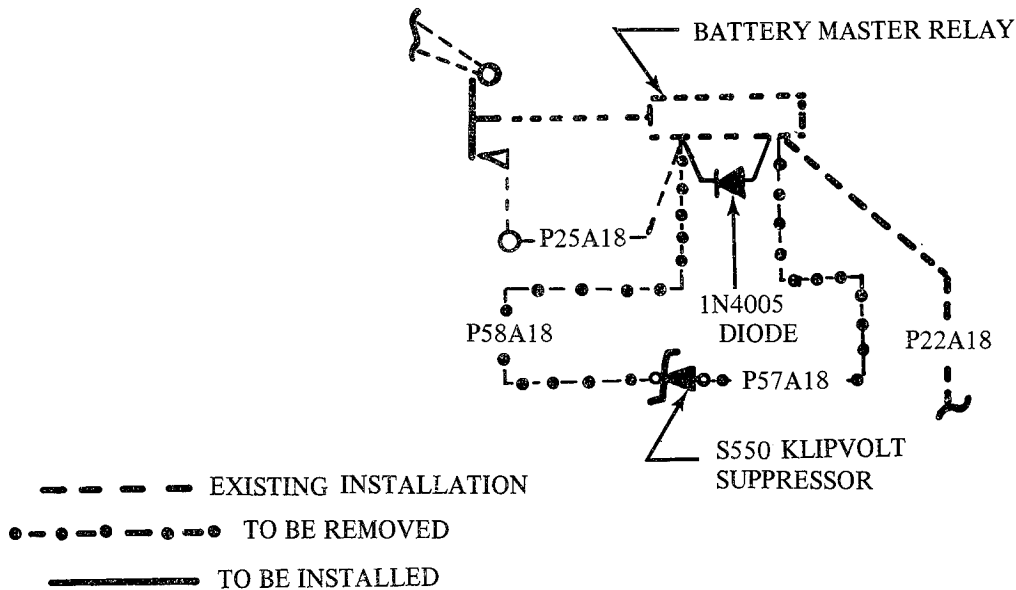

Wiring Diagram

