

EDO AVIONICS
CORPORATION DIVISION

**CENTURY
II, IIB & III**

Flight Systems

Service Manual

68S54

73

TABLE OF CONTENTS

SECTION	PAGE
I. SYSTEM THEORY.1-1
1.1 CENTURY II BASIC OPERATION.1-1
1.2 CENTURY III BASIC OPERATION.1-7
1.3 RADIO COUPLER.1-13
1.4 GLIDE SLOPE COUPLER.1-16
1.5 STABILIZER AND OMNI TRACKER.1-19
1.6 AUTOMATIC TRIM SYSTEM.1-21
II. AUTOPILOT DATA SHEETS.2-1
INDEX.2-1
AERO COMMANDER.2-3
AMERICAN AVIATION.2-9
BEECHCRAFT.2-11
BELLANCA.2-61
BRITTEN-NORMAN.2-65
CESSNA.2-67
DEHAVILLAND.2-121
HELIO.2-123
MAULE.2-125
PIPER.2-127
WREN.2-139
III. TEST EQUIPMENT IN AIRCRAFT TROUBLESHOOTING.3-1
3.0 GENERAL.3-1
3.1 66D141 TEST SET.3-1
3.2 CENTURY II TROUBLESHOOTING.3-2
3.2.1 Quick Check.3-2
3.2.2 Checking the Century II Console Amplifier 1C385 with the 66D141 Test Set.3-4
3.2.3 Checking the Roll Servo.3-7
3.2.4 Checking the Artificial Horizon.3-8
3.2.5 Checking the Directional Gyro.3-9
3.2.6 Checking the Radio Coupler.3-10
3.3 CENTURY III TROUBLESHOOTING.3-13
3.3.1 Quick Checks.3-13
3.3.2 General.3-13
3.3.3 Century III A+ Checks.3-13
3.3.4 Roll Section Checks.3-13
3.3.5 Pitch Section Checks.3-17
3.3.6 Radio Coupler Checks.3-18
3.3.7 Glide Slope Coupler Checks.3-18
3.3.8 Automatic Pitch Trim.3-18
IV. REPAIR AND OVERHAUL.4-1
4.1 GENERAL.4-1
4.2 1C385 CENTURY II AND IIB CONSOLE/AMPLIFIER.4-1
4.2.1 (a) Century II Theory4-1
4.2.1 (b) Century IIB Theory.4-2
4.2.2 Century II Console/Amplifier Tests.4-3
4.2.3 Century IIB Console/Amplifier Tests.4-4
4.3 1D395, 1C515 AND 1C515-1 & -2 AMPLIFIERS.4-11
4.3.1 Theory (1D395 Amplifier).4-11
4.3.2 Theory (1C515 Amplifier).4-

SECTION	PAGE
4.3.3 Theory (1C515 -1 & -2 Amplifiers)	4-13
4.3.4 Century III 1D395 and 1C515 Amplifier Tests.	4-13
4.3.5 Century III 1C515 -1 & -2 Amplifier Tests.	4-15
4.4 ROLL SIGNAL FILTER.	4-29
4.5 PITCH SIGNAL FILTER.	4-34
4.6 RADIO COUPLERS.	4-34
4.6.1 Theory.	4-34
4.6.1 (a) 1C388 Radio Coupler - Serial No. 6,000 and above.	4-34
4.6.1 (b) 1C388 Radio Coupler - Serial No. 1,480 to 6,000.	4-36
4.6.1 (c) 1C388C and 1C388MC Radio Couplers.	4-45
4.6.2 Radio Coupler 1C388 Tests (Serial No. 6,000 and above).	4-45
4.6.3 Radio Coupler 1C388 Tests (Serial No. 6,000 and below).	4-46
4.7 GLIDE SLOPE COUPLER.	4-47
4.7.1 Theory.	4-47
4.7.2 Glide Slope Coupler Tests.	4-48
4.8 TRIM AMPLIFIERS - 79C54 & 79C53.	4-53
4.9 TRIM AMPLIFIERS - 1C646 & 1C671.	4-54
4.10 TRIM AMPLIFIERS - 1B369 & 1B389.	4-54
4.11 SYNCHRONOUS FILTERS.	4-66
4.12 PHASE DETECTOR.	4-67
V. WIRING DIAGRAMS.	5-1
(See List of Illustrations for Contents)	
VI. GROUND CHECKS AND FLIGHT ADJUSTMENTS.	6-1
6.1 CENTURY II AND IIB AUTOPILOTS.	6-1
6.1.1 Ground Checks.	6-1
6.1.2 Flight Checks.	6-2
6.2 CENTURY III AUTOPILOTS.	6-5
6.2.1 Ground Checks.	6-6
6.2.2 Ground Checks and Adjustment - Automatic Pitch Trim.	6-7
6.3 AUTOMATIC PITCH TRIM SYSTEMS.	6-8
6.3.1 General.	6-8
6.3.2 Ground Checks.	6-8
6.4 FLIGHT ADJUSTMENTS FOR 1C515-() AMPLIFIERS.	6-9
6.4.1 Roll Threshold (Rth) Adjustment.	6-10
6.4.2 Pitch Threshold (Pth) Adjustment.	6-10
6.5 FLIGHT ADJUSTMENTS - ALL CENTURY III.	6-10
6.5.1 Roll - No Radio Coupler.	6-10
6.5.2 Roll - With Radio Coupler.	6-11
6.5.3 Pitch.	6-12
6.7 GLIDE SLOPE COUPLER.	6-14
6.7.1 In-Flight Adjustment Procedure for 1C493 Glide Slope Coupler Without 66D94 Test Box.	6-14
6.7.2 In-Flight Adjustment Procedure for 1C493 Glide Slope Coupler With 66D94 Test Box.	6-14

LIST OF ILLUSTRATIONS

FIGURE	TITLE	PAGE
1-1	THE CENTURY FAMILY OF AUTOPILOTS	
1-2	CENTURY II AND IIB CONSOLE/AMPLIFIER.1-1
1-3	DIRECTIONAL GYRO (52D54).1-2
1-4	AIRCRAFT TRIM EFFECTS.1-3
1-5	CENTURY II SYSTEM CONFIGURATIONS.1-4
1-6	BLOCK DIAGRAM - CENTURY II CONSOLE/AMPLIFIER.1-5
1-7	CENTURY III CONSOLE.1-7
1-8	CENTURY III SYSTEM CONFIGURATIONS.1-10
1-9	BLOCK DIAGRAM - CENTURY III 1D395 AMPLIFIER.1-12
1-10	RADIO COUPLER.1-14
1-11	BLOCK DIAGRAM - RADIO COUPLER 1C388.1-15
1-12	BLOCK DIAGRAM - GLIDE SLOPE COUPLER 1C493.1-17
1-13	WIND EFFECTS ON APPROACH.1-18
1-14	STABILIZER/TRACKER SYSTEM.1-20
1-15	BLOCK DIAGRAM - STABILIZER/TRACKER.1-20
1-16	BLOCK DIAGRAM - AUTOMATIC TRIM SYSTEM.1-22
1-17	TYPICAL TRIM SENSORS.1-23
1-18	TYPICAL TRIM SERVO AND AMPLIFIERS.1-24
1-19	TRIM TAB OPERATION.1-25
1-20	TRIM SENSOR IN "UP ELEVATOR" CONDITION.1-26
1-21	TRIM SENSOR IN "DOWN ELEVATOR" CONDITION.1-26
3-1	66D141 TEST SET.3-3
3-2	QUICK CHECKS CENTURY II TROUBLESHOOTING LOGIC CHART.3-5
3-3	CENTURY II INTERCONNECT WIRING DIAGRAM.3-6
3-5	CENTURY III TEST SET-UP.3-12
3-6	QUICK CHECKS CENTURY III TROUBLESHOOTING LOGIC CHART.3-15
3-7	CENTURY III INTERCONNECT WIRING DIAGRAM.3-16
4-1A	CENTURY III SCHEMATIC.4-5
4-1B	CENTURY II PRINTED CIRCUIT BOARD.4-6
4-1C	CENTURY IIB SCHEMATIC.4-7
4-1D	CENTURY IIB PRINTED CIRCUIT BOARD.4-8A
4-2	CENTURY II TEST SET-UP.4-9
4-3	CENTURY II & IIB CONSOLE ADJUSTMENTS.4-10
4-4	CENTURY III CONSOLE SCHEMATIC.4-18
4-4A	1D395 AMPLIFIER SCHEMATIC.4-19
4-4B	1D395 AMPLIFIER PRINTED CIRCUIT BOARD.4-20
4-5A	1C515 AMPLIFIER SCHEMATIC.4-21
4-5B	1C515 AMPLIFIER PRINTED CIRCUIT BOARD.4-23
4-6A	1C515 -1 & -2 AMPLIFIER SCHEMATIC.4-24
4-6B	1C515-1 & -2 AMPLIFIER PRINTED CIRCUIT BOARD.4-26
4-7	CENTURY III AMPLIFIER TEST SET-UP.4-27
4-8	SELECTOR RESISTOR CHART.4-28
4-9A	ROLL SIGNAL FILTER 1B440 SCHEMATIC.4-30
4-9B	ROLL SIGNAL FILTER PRINTED CIRCUIT BOARD.4-31
4-10A	PITCH SIGNAL FILTER SCHEMATIC.4-32
4-10B	PITCH SIGNAL FILTER PRINTED CIRCUIT BOARD.4-33
4-11A	1C388 RADIO COUPLER SCHEMATIC - S/N 6,000 & ABOVE.4-37
4-12A	1C388 RADIO COUPLER SCHEMATIC - S/N 1,480 TO 6,000.4-38
4-13A	1C388 RADIO COUPLER SCHEMATIC - S/N UP TO 1,480.4-39
4-11B	1C388 RADIO COUPLER PRINTED CIRCUIT BOARD S/N 6,000 & ABOVE.4-40
4-12B	1C388 RADIO COUPLER PRINTED CIRCUIT BOARD S/N 1,480 TO 6,000.4-41
4-13B	1C388 RADIO COUPLER PRINTED CIRCUIT BOARD S/N UP TO 1,480.4-42
4-14	1C388C RADIO COUPLER SCHEMATIC S/N 6,000 & ABOVE.4-43
4-15	1C388C RADIO COUPLER SCHEMATIC S/N 1,480 TO 6,000.4-44

FIGURE	TITLE	PAGE
4-16	CENTURY II RADIO COUPLER TEST SET-UP.	4-44A
4-17	CENTURY III RADIO COUPLER TEST SET-UP.	4-44B
4-18	GLIDE SLOPE COUPLER TEST SET-UP.	4-50
4-19A	GLIDE SLOPE COUPLER SCHEMATIC.	4-51
4-19B	GLIDE SLOPE COUPLER PRINTED CIRCUIT BOARD.	4-52
4-20A	TRIM AMPLIFIER 79C54 SCHEMATIC.	4-55
4-20B	TRIM AMPLIFIER 79C54 PRINTED CIRCUIT BOARD.	4-56
4-20C	TRIM AMPLIFIER 79C54-3 SCHEMATIC.. . . .	4-57
4-21A	TRIM AMPLIFIER 79C53 SCHEMATIC.	4-58
4-21B	TRIM AMPLIFIER 79C53 PRINTED CIRCUIT BOARD.	4-59
4-22A	TRIM AMPLIFIER 1C646 SCHEMATIC.	4-60
4-22B	TRIM AMPLIFIER 1C646 PRINTED CIRCUIT BOARD.	4-61
4-23A	TRIM AMPLIFIER 1C671 SCHEMATIC.	4-62
4-23B	TRIM AMPLIFIER 1C671 PRINTED CIRCUIT BOARD.	4-63
4-24A	TRIM AMPLIFIER 1B369 & 1B389 SCHEMATIC.. . . .	4-64
4-24B	TRIM AMPLIFIER 1B369 & 1B389 PRINTED CIRCUIT BOARD.	4-65
4-25	SYNCHRONOUS FILTER.	4-66
4-27	ONE HALF CYCLE CONDITION.. . . .	4-68
4-28	PHASE DETECTOR.	4-68
5-1	CENTURY III 30D207 CABLE HARNESS.	5-1
5-2	CENTURY II 30B198 CABLE HARNESS.	5-2
5-3	GLIDE SLOPE COUPLER 30C291 CABLE HARNESS.. . . .	5-3
6-1	CENTURY IIB CONSOLE/AMPLIFIER.	6-3
6-2	CENTURY III CONSOLE (1C404).. . . .	6-13
6-3	66D94 TEST BOX.	6-15

LIST OF TABLES

TABLES	TITLE	PAGE
4-1	TRIM AMPLIFIER PARTS LIST CHART	3-19
4-2	TRIM AMPLIFIER TEST PROCEDURES AND CENTERING ADJUSTMENTS.	3-22

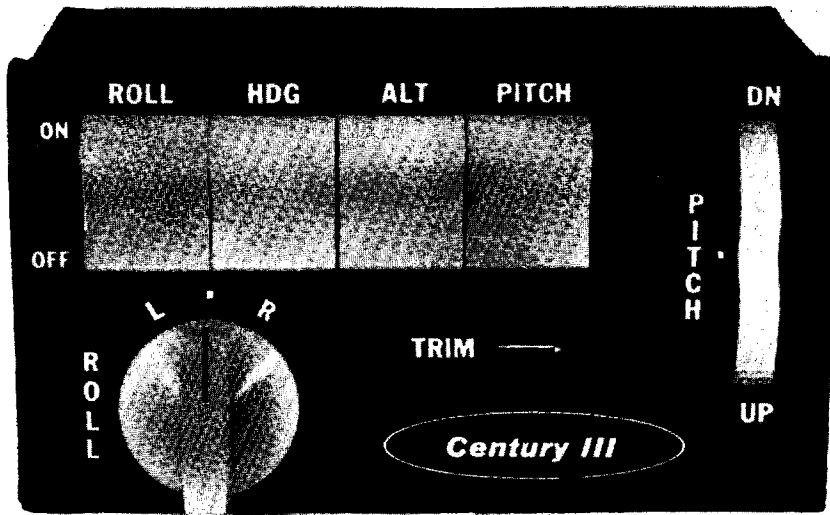

Century III

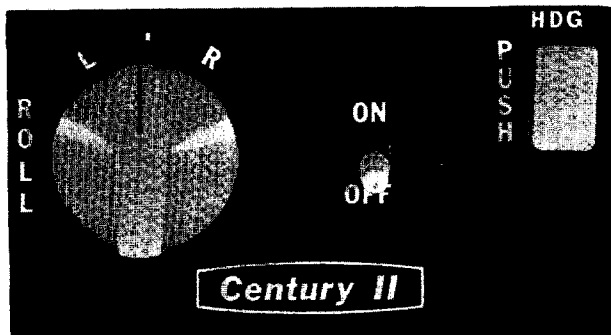

Century II

Century II B

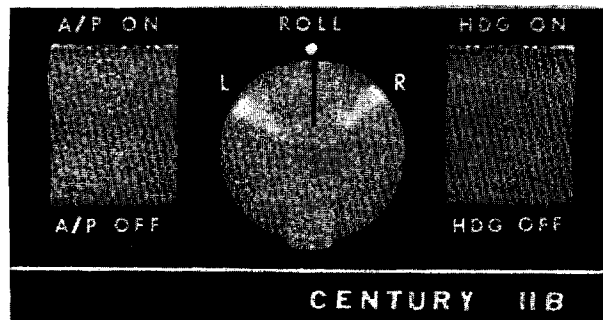

FIGURE 1-1
THE CENTURY FAMILY OF AUTOPILOTS

SECTION I
SYSTEM THEORY

1.1 CENTURY II: BASIC OPERATION

1.1.1 Operator's Manual Extracts - The Century II Autopilot is an extremely simple, all electronic, two-axis autopilot system. It is called a two-axis system because it controls both Heading and Roll.

Before discussing "How It Works", sections of the Operator's Manual are extracted below to acquaint you with "How To Work It".

Roll (Aileron) Engagement - The Century II incorporates a fail-safe electrical engage and disengage mechanism in the roll servo which is operated by an ON-OFF switch in the console (Fig. 1-2). When this switch only is engaged, the autopilot is responsive to only the roll axis outputs of the attitude gyro and the commands of the console roll/turn control.

Roll Command Knob - The roll command knob can be used to maneuver the aircraft through the roll axis without the D.G. Hdg. command. When the Heading mode switch is engaged the roll knob is removed from the autopilot and is ineffective. However; it should be left in the centered position, for convenience, in case the roll switch is engaged.

Heading Mode - The heading mode switch is located to the right of the engage switch on the Century console. It is the function of this Push On-Push Off Switch to remove the roll command knob from the autopilot circuit and add the D.G. heading command and the optional coupler functions to the basic roll attitude control. Prior to engagement of the heading mode, the D.G. course selector and coupler modes should be preset.

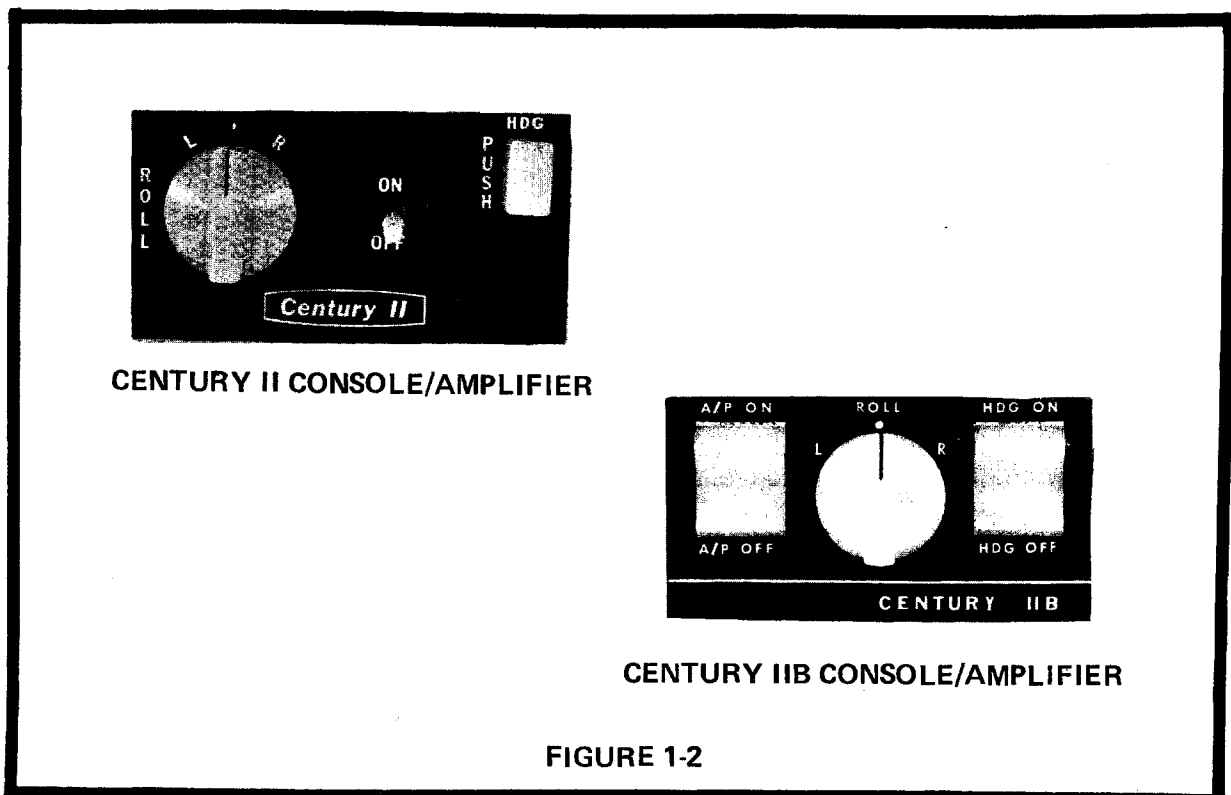
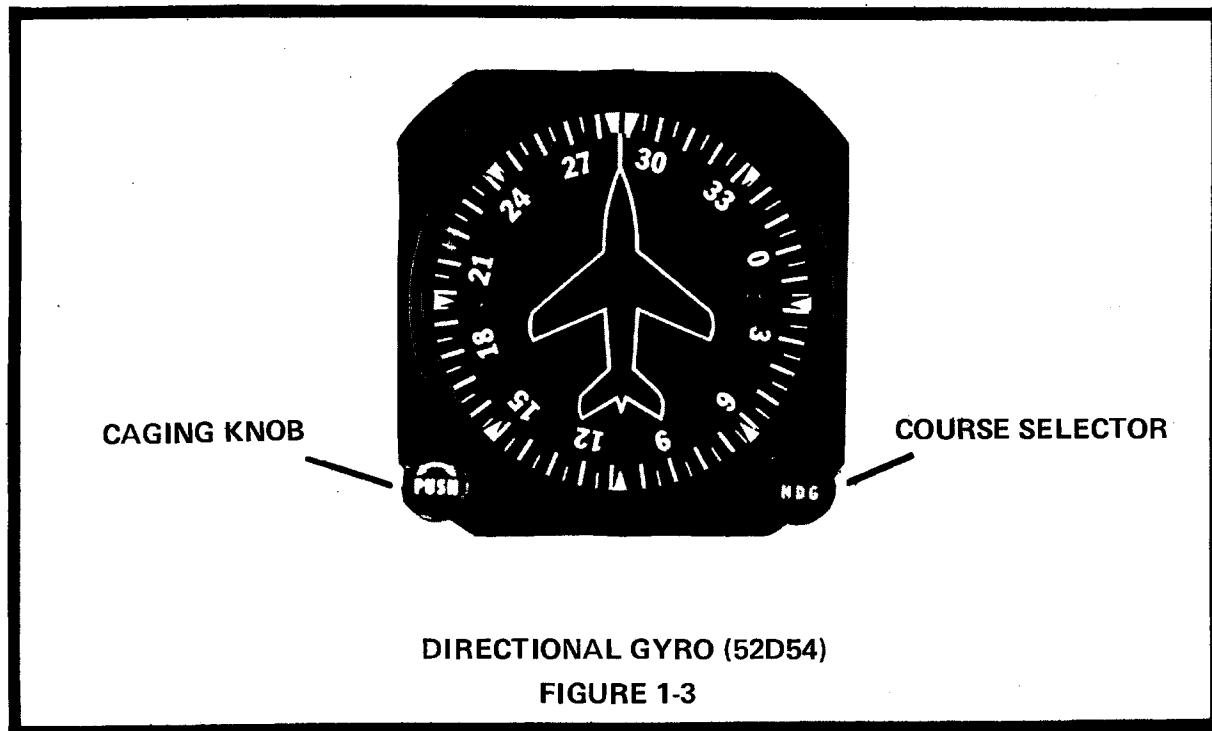

FIGURE 1-2

Course Selector D.G. - The course selector D.G. (Fig. 1-3) replaces the standard directional gyro and provides a fully visible course indicator around the normal D.G. opening. The D.G. dial is marked in 5° intervals and numbered each 30° around its azimuth. A center indice is provided at the top to align selected heading. Additional indices are located each 45° to facilitate rapid heading selection without mental arithmetic. Any heading may be selected, either before or after engagement and turns up to 180° may be programmed directly, either right or left. If the course indicator is rotated beyond 180° from the D.G. dial heading, the course selector will command a reversal on bank to reach the resultant selected heading in the shortest direction.

The D.G. dial is normally set to the magnetic compass with the caging knob on the left in the usual fashion while the course selector indicator is rotated by the Hdg. Knob on the right. Direction of rotation of both the knob and indicator commands the same direction of turn.



Aircraft Trim Effects - An important axiom to remember is that if the airplane is properly "trimmed", an Edo Avionics autopilot in heading mode will never fly the airplane with a wing down.

This statement can be changed slightly to apply to an airplane without an autopilot; In order to fly a "trimmed" airplane on a constant heading, the wings must be held level.

Consider the effect of rudder trim in Figure 1-4. Viewing the airplane from the rear, note that with left rudder applied the right wing must be lowered to offset the rudder effect and keep the heading constant, i. e., the left turn effect of the rudder is canceled by the right turn effect of the bank.

Since the autopilot is slaved to a heading this is exactly what it will do in order to maintain that heading when the rudder is out trim.

Thus when operating on autopilot heading mode with a wing down, rudder trim in the direction toward the low wing is required.

1.1.2 System Configuration - As can be seen from the Operator's Manual, the Century II is an easy system to operate. The most complicated Century II consists of only six parts (seven, considering the interconnecting electrical cable harness) as illustrated in Fig. 1-5. They are as follows:

1. Console-Amplifier - The Console-Amplifier is the focal point of the Century II autopilot. It is both the command console through which the pilot operates the autopilot, and the computer which provides the necessary mixing of signals and voltage amplification to drive the autopilot servos. The Console-Amplifier provides reference excitation voltages to the Directional Gyro and Artificial Horizon which in turn supply the Console-Amplifier with the needed roll reference and directional command signal to fly the aircraft.

2. Artificial Horizon - The Artificial Horizon provides the roll reference signal for the system. It receives excitation from the console-amplifier and converts it to an attitude reference signal to tell the autopilot the roll attitude of the aircraft. Loss of this roll attitude signal will cause the autopilot to fly with its "eyes closed" and therefore it may fly at any bank angle—even upside down.

3. Directional Gyro - The Directional Gyro (D.G.) supplies "compass" information to the Century II. It also receives and controls the frequency of the reference excitation signal used by the system. The pilot, by selecting a heading on the D.G. (aligning "Heading bug"), directs the autopilot to fly that heading.

4. Roll Servo - The Roll Servo receives power from the console amplifier and applies force to the aircraft controls. A solenoid controls engagement to the controls and a force limiting clutch is provided to limit the maximum force the servo can apply. The setting of the clutch is determined during F.A.A. certification and its maximum setting as contained in the servo data should never be exceeded.

5. Roll Signal Filter - The Roll Signal Filter is a "Rate" circuit that plugs in line with the Artificial Horizon. Its purpose is to tell the console-amplifier "how fast" the aircraft is rolling in one direction or the other. The Roll Signal Filter is not used in all types of aircraft. Its need is determined during the F.A.A. certification. In general, incorrect operation of the Roll Signal Filter will cause "overshooting of bank angles or control wheel nervousness".

6. Radio Coupler - The Radio Coupler is an option with all Century II systems except those with PN101's, KPI-550, etc. The Radio Coupler plugs in line with the D.G. and provides radio coupling for navigation and approaches. When a PN101 or KPI-550 is used with the Century II, a special radio coupler, 1C388-C (Collins), must be used to provide correct matching of the heading datum synchro to the autopilot.

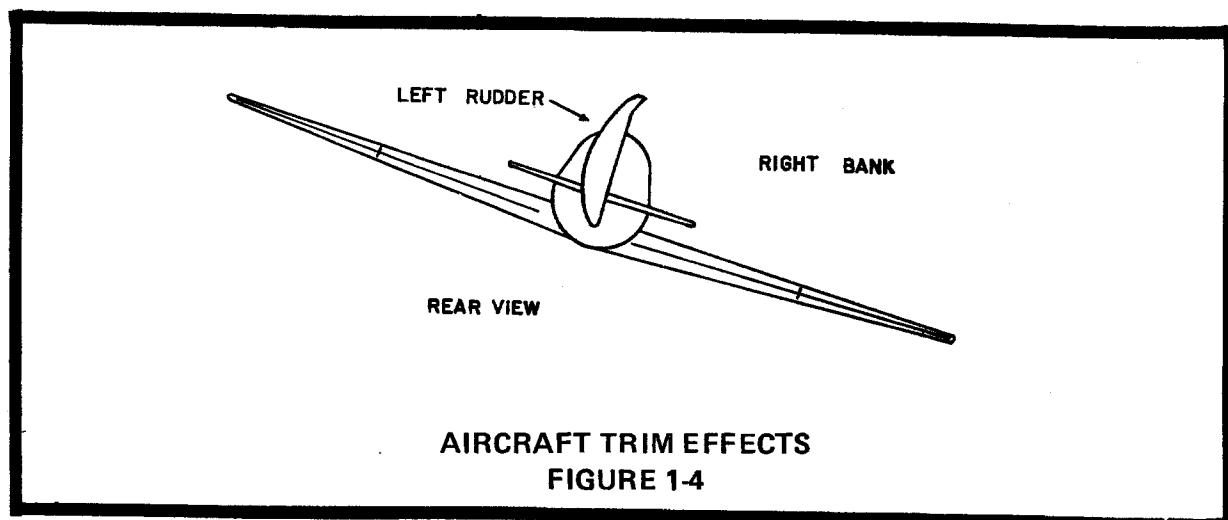

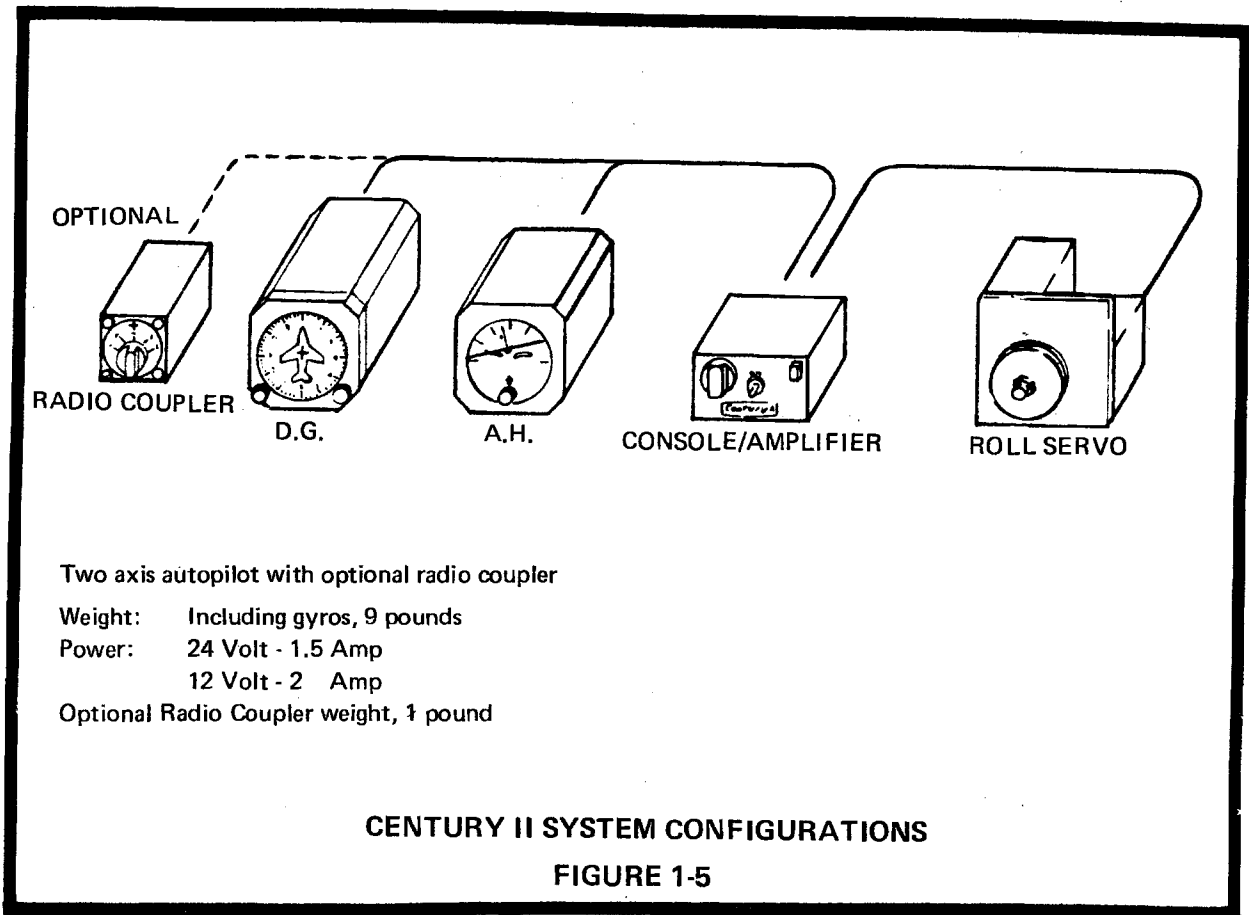

1.1.3 Basic Signal Flow - In the block diagram (Fig. 1-6) aircraft A+ power is supplied to the console amplifier where it is controlled by the ON-OFF switch on the console. After the switch, A+ goes three ways:

1. To the servo engage solenoid.
2. To the servo amplifier circuit.
3. To the voltage regulator and then to the 5KHz oscillator.

The Oscillator supplies the 5 KHz regulated excitation in a 27 ± 1 volt peak to peak square wave to:

1. Internal circuits of the console-amplifier.
2. The D.G. and Radio Coupler if installed.
3. The Artificial Horizon.

The excitation is used in the console-amplifier to:

1. Generate the Roll Command Signal.
2. Control timing circuits (synchronous filters) (Phase detectors).
3. Supply regulated power for amplifier.

The D.G. uses the excitation to generate a "Heading Error Signal" that tells the autopilot how far the heading bug is from the "Lubber Line" on the gyro and which way it needs to turn to get the bug back under the "Lubber Line". The Radio Coupler uses the excitation for power and timing circuits.

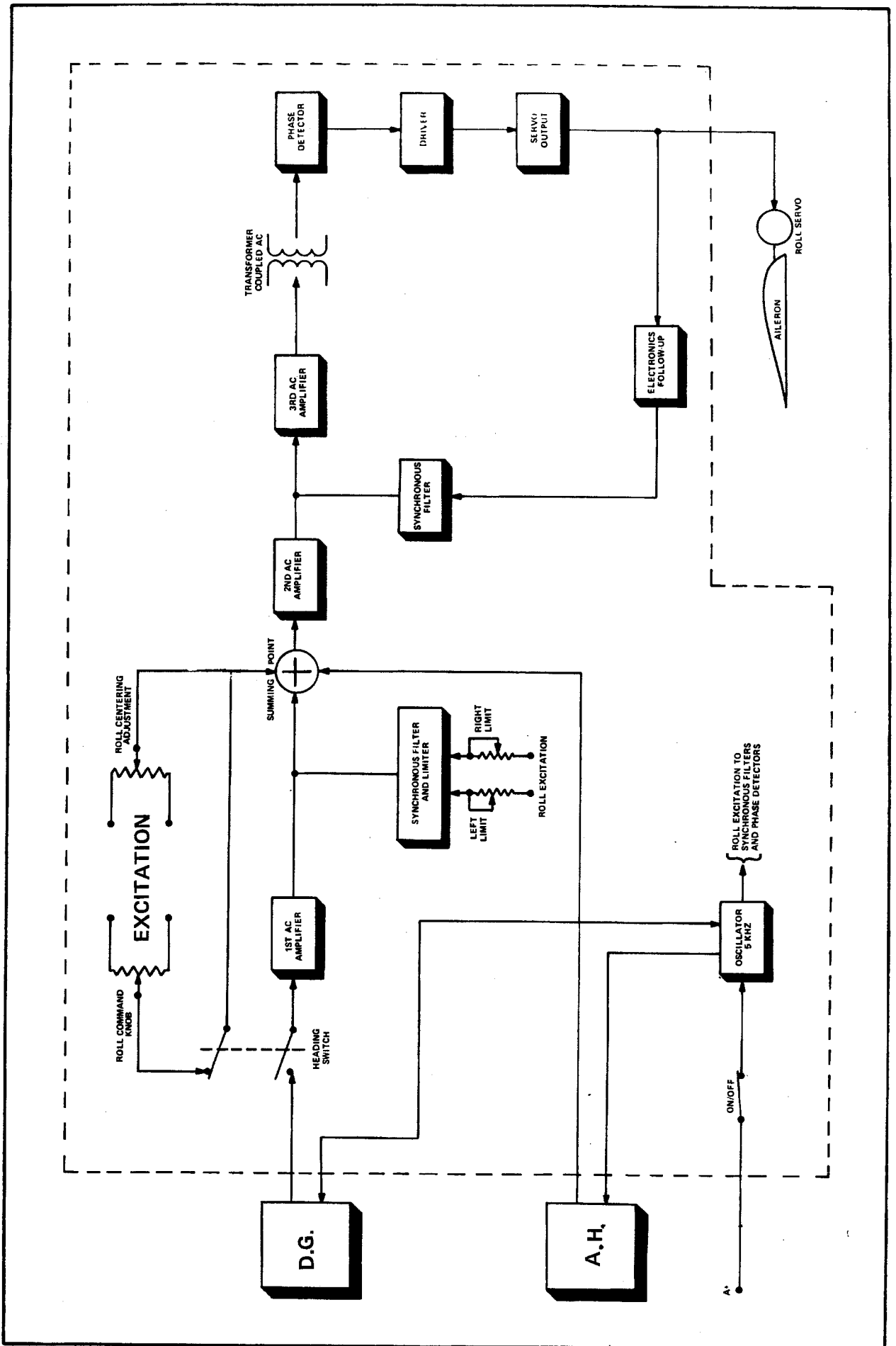

BLOCK DIAGRAM - CENTURY II CONSOLE/AMPLIFIER
 FIGURE 1-6

The Artificial Horizon uses the excitation to generate an Attitude Reference Signal that tells the autopilot the attitude of the aircraft. If a roll signal filter is installed, it uses excitation for power.

As you can see, the excitation signal is very important and anything that disturbs the excitation signal will affect the autopilot though sometimes, the effect is very subtle.

Signal Processing - The most important signal in the autopilot is the Attitude Reference Signal from the Artificial Horizon. Its signal is fed directly to the summing point in the console-amplifier which represents aircraft position. (or position plus rate if a roll signal filter is used). With only this signal, the aircraft can fly straight and level if all adjustments are correct.

To cause turns, the signal from the Roll Command knob is also supplied to the summing point at which time the aircraft will bank until the horizon signal cancels the command signal. It will stay banked until a different command is injected by the pilot.

The D.G. Signal will also cause a bank in the same manner as the roll command knob, but as the aircraft nears the selected course, the command decreases until the aircraft rolls out on the selected heading. Bank limiting is provided by limiting the maximum amplitude of the command and D.G. signal. The Horizon Signal is not limited in any way.

After signals are mixed at the summing point, they are amplified by the second AC amplifier, processed by the second synchronous filter and amplified by the third AC amplifier. They are then transformer coupled to the phase detector, changed to DC, amplified by the driver and the servo output, and sent to the servo motor to move the aircraft controls. Some of the voltage to servo motor is tapped off and sent to the "Electronic Follow-Up Circuit", which is an electronic model of the servo motor. The output of this circuit is used to control the servo amplifier and prevent oscillation.

While this has been a rather brief explanation, a more detailed explanation of the theory of operation of individual circuits may be found in the repair and overhaul section under the specific component containing the circuit. This explanation has been provided to assist troubleshooters in understanding the role that each part plays in the system. For it is only through understanding that the system can be efficiently serviced, adjusted and faulty components located.

The Century IIB system is identical with the Century II and the console-amplifiers are interchangeable except for the retaining clip. The Century IIB offers the following additional features:

1. Easier Operation.
2. Improved switches and heavy-duty internal components.
3. Adjustable roll threshold for "Fine Tuning" the electronic follow-up.
4. Smoother roll action.

1.2 CENTURY III: BASIC OPERATION

1.2.1 **Operator's Manual Extracts** - The Century III is a light weight (approximately 18 pounds), all electronic, three axis autopilot system. It is called a three axis system because it controls heading, roll and pitch. Note that the standard Century III, although referred to as a three axis system, contains only two controls servos.

Before discussing the general theory of operation of the Century III, it is necessary to know how the system operates; therefore, the following extracts from the Century III Pilot's Operating Manual are provided. If you happen to have a copy of the Pilot's Operating Manual handy and are not familiar with the Century III, it would be helpful for you to read the entire manual.

Command Console - The Century III console (Fig. 1-7) is designed to provide convenient fingertip command of all basic autopilot functions. Magnetic engage and mode switches are designed with logical interlocking features for operational ease and simplicity. The lucite face panel incorporates optically engineered night lighting with provisions for dimming control through the standard aircraft instrument rheostat.

Roll (Aileron) Engagement - The Century III is separated into two distinct systems, the Roll/Heading and Pitch Altitude. Each is engaged separately by means of a fail-safe electric servo engage mechanism.

The Roll engage acts as an autopilot master switch as well as the roll engage switch. In this capacity the roll must be engaged for all other engage and mode switches to become operative. With this roll switch only engaged, the autopilot is responsive only to the roll axis of the attitude gyro and the commands of the console roll/turn control.

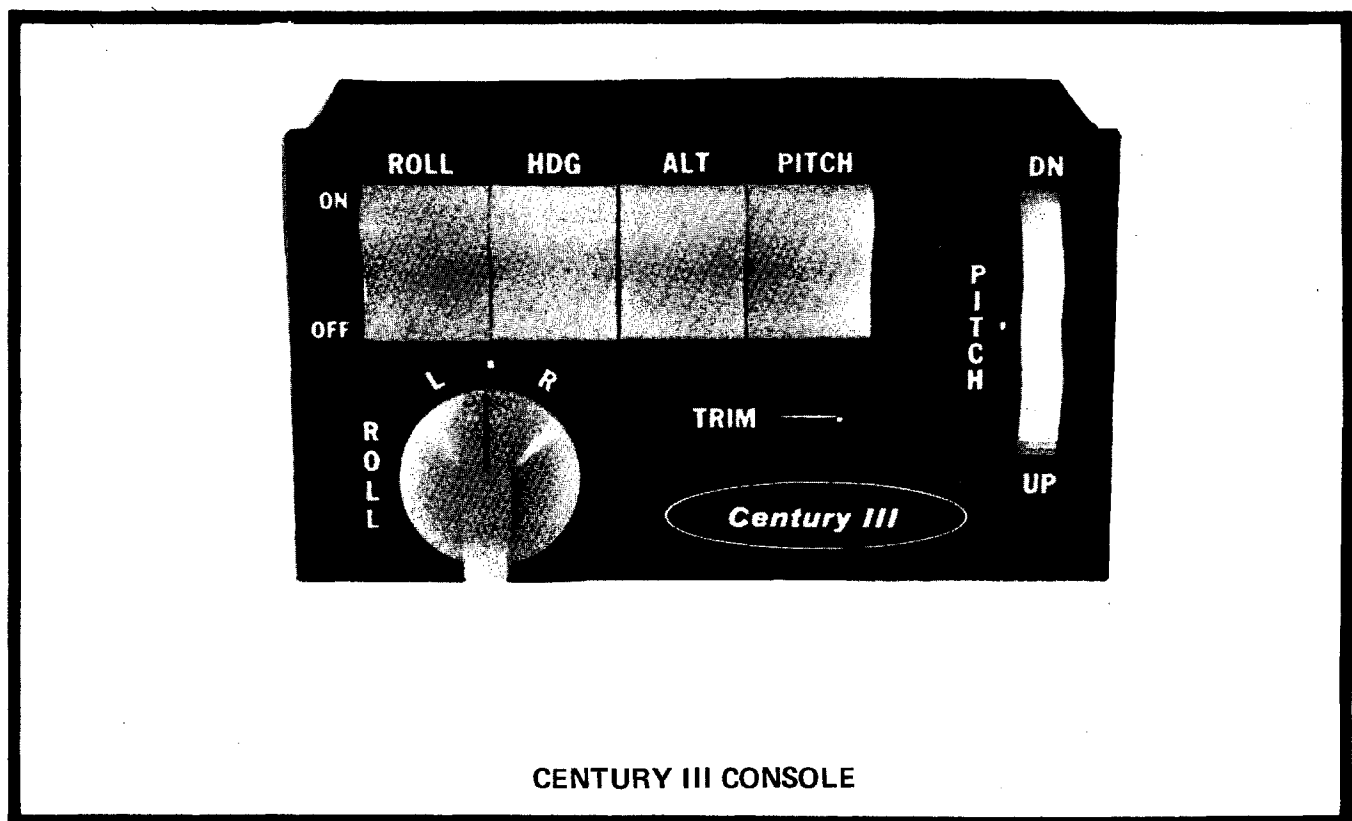

FIGURE 1-7

Roll Command Knob - The roll command knob controls the roll axis of the aircraft when roll mode switch is engaged. It is useful in maneuvering and will permit steeper bank angles (up to 30°) than those resulting from D.G. heading commands. When the heading mode switch is engaged, the roll knob is removed from the autopilot circuit and is ineffective. However it should be left in the centered position for convenience. NOTE: Do not use roll mode during approach configuration on twin engine aircraft as engine failure will result in excessive heading deviation.

Heading Mode - The heading mode switch is located directly adjacent and to the right of the roll engage switch. It is the function of the heading mode switch to remove the roll command knob from the autopilot circuit and add the D.G. heading command and coupler functions to the basic roll attitude control. This switch is interlocked with the roll engage so that the roll function will be engaged simultaneously with the heading mode switch. Prior to engagement of the heading mode, the D.G. course selector and coupler modes should be set. (See sections on coupler operation when optional coupler is installed).

Course Selector D.G. - The course selector D.G. dial is marked in 5° intervals and numbered each 30° around its azimuth. A center indice is provided at the top to align selected heading. Additional indices are located each 45° to facilitate rapid heading selection without mental arithmetic. Any heading may be selected, either before or after engagement, and turns up to 180° may be programmed directly, either right or left. If the course indicator is rotated beyond 180° from the D.G. card heading, the course selector will command a reversal in bank to reach the resultant selected heading in the shortest direction.

The D.G. dial is normally set to the magnetic compass with the caging knob on the left in the usual fashion, while the course selector indicator is rotated by the heading knob on the right. Direction of rotation of both the knob and indicator commands the same direction of turn.

Trim Indicator and Pitch Command Wheel - Prior to engagement of the pitch axis, it is desirable to adjust the autopilot pitch to match the attitude being flown. In this way the pilot can transition from hand flight to autopilot smoothly during the climbout or other pitch maneuvering.

The pitch servo effort meter (labeled "Trim") to the left of the pitch control wheel receives the same error signal as the servo amplifier. Therefore, the effort meter indicates the difference between the autopilot pitch command setting and the attitude of the aircraft.

Thus, if it is pointing upward prior to pitch mode engagement, it indicates that the aircraft can be expected to increase pitch upon engagement. Conversely a down needle indicates a decrease pitch attitude upon engagement.

For a smooth transition, the needle should be centered manually by the pitch command knob before the pitch mode is engaged. After engagement, the needle will stay centered because the servo continuously commands or flies the aircraft to null or zero out the error signal.

The pitch command wheel is in the autopilot circuit when the pitch mode switch only is engaged. It is removed from the circuit and becomes ineffective upon engagement of the altitude hold. During altitude hold operation it may be set to level or preprogrammed to produce a climb or descent upon altitude hold disengagement.

Pitch (Elevator) Engagement - The pitch mode switch engages the autopilot pitch servo and makes the autopilot responsive to the pitch attitude of the artificial horizon and commands of the pitch command wheel. Pitch attitudes may be directed by rotating the command in the appropriate direction. The computer system in combination with optional automatic trim will maintain this constant attitude through power changes and during gear and flap position transitions. On aircraft not equipped with the Edo-Aire Mitchell automatic trim, it will be necessary to disengage the pitch and manually trim the airplane during attitude, airspeed, or gear flap transitions. (See section on automatic trim).

Altitude Hold - The altitude hold is a "command" type which requires no pitch command adjustment prior to engagement. Engagement of the altitude mode switch will remove the pitch command wheel from the circuit and initiate a smooth transition to the pressure altitude at which it was engaged. Barometric sensors provide precise altitude holding with nominal climb and dive limitations for operation in turbulence.

Automatic Trim Operations - The Edo Avionics automatic trim provides full time automatic trim with the autopilot on. The system is F.A.A. approved for full time use from take off to touchdown.

When the autopilot pitch is engaged, the trim system goes on full time and will correct aircraft trim to the attitude and airspeed changes that are called for by the autopilot pitch command, power changes, etc.

When the autopilot is off, the trim button on the control wheel is depressed by the pilot any time he wishes to relieve control forces. This will be particularly helpful during approaches when speed is being reduced and additional trim changes are required by the lowering of flaps and gear.

The pilot can override the trim system at any time by manual operation of the aircraft trim control. In addition, the circuit breaker switch labeled "Trim" on the instrument panel may be pulled to disconnect the electric trim system from the aircraft electrical system.

1.2.2 System Configuration - The basic Century III consists of seven components, not counting the cable harness. With all of its options, the total system is made up of twelve components. These components are illustrated in Fig. 1-8 and are as follows:

1. **Console** - The console is the link between the pilot and the electronic "brain of the autopilot. Through the console system A+ is controlled and all of the basic autopilot functions are commanded to the computer/amplifier. The console also contains the limit and centering potentiometers used during initial flight adjustments. These adjustments are located under the face plate.

2. **Amplifier** - The amplifier contains the computer logic circuits and amplifiers that provide the command signals to the roll and pitch servos. Also, all reference signals such as those from the D.G. and artificial horizon and all command signals from the console are mixed and processed within the amplifier.

3. **Artificial Horizon** - The artificial horizon provides roll and pitch references for the system. It receives excitation from the amplifier and converts it to attitude reference signals which tell the autopilot the roll and pitch attitude of the aircraft. As with the Century II system, loss of the attitude signals would cause the aircraft to fly at any bank angle or at any pitch attitude. Without attitude reference, the autopilot is "blind" and therefore could not tell the difference between right side up or upside-down.

4. **Directional Gyro** - The Directional Gyro (D.G.) provides a "sense of direction" for the autopilot. The pilot, by selecting a heading on the D.G., directs the autopilot to fly that heading. This is accomplished through the excitation signal which the D.G. converts to a heading signal and applies to the amplifier. One other function of the D.G. in the Century III system is controlling the system excitation frequency. The D.G. contains the tuned circuits for the excitation oscillator contained within the amplifier.

5. **Altitude Hold Sensor** - The Altitude Hold Sensor supplies the Century III with an altitude reference signal. The sensor will lock on to the indicated altitude when the altitude mode button on the console is pressed. As long as the aircraft remains at that altitude, the sensor will supply a nulled or zero signal to the amplifier. Any deviation in altitude causes a signal change which is applied to the amplifier and processed to correct the altitude deviation.

6. Roll Servo - The Roll Servo provides the force to control the aircraft ailerons. It receives its power from the amplifier. A solenoid controls engagement of the servo to the controls and a force limiting clutch is provided to limit the maximum force applied by the servo. The setting of the clutch is determined during F.A.A. certification and its maximum setting as contained in the servo data should never be exceeded.

7. Pitch Servo - The Pitch Servo is identical to the roll servo except it controls the elevator or stabulator of the aircraft. It also receives its power from the amplifier.

8. Radio Coupler - The Radio Coupler is an optional unit which provides radio coupling for navigation and approaches when plugged in line with the system's D. G. Three types of radio couplers are used with the system, depending on the aircraft's radio and navigation display system. The 1C388 coupler is used with all systems using a standard Omni/Localizer Converter and Edo Avionics 52D54 Directional Gyro as course and heading inputs. The 1C388-C coupler is required when the Century III is coupler to navigation systems such as the PN101, KPI-550, etc., and the 1C388-2 Radio Coupler is used with Edo Avionics NSD-360 Navigation Situation Display.

9. Glide Slope Coupler - The glide slope coupler is an automatic analog computer that directs the autopilot to intercept and track the approach glide path. This unit, together with the Radio Coupler, provides a complete and automatic ILS intercept capability for the Century III autopilot.

10. Automatic Pitch Trim System - This system consists of a trim amplifier, servo and sensor which provides automatic trim corrections. A detailed discussion on its operation is provided in paragraph 1.6 of this section.

11. Stabilizer and Omni Tracker Back-Up System -(Optional) - The stabilizer back-up system is a yaw and roll axis stabilizer which is capable of performing short term heading as well as omni navigation course functions. Refer to paragraph 1.5 of this section for a complete description of this system.

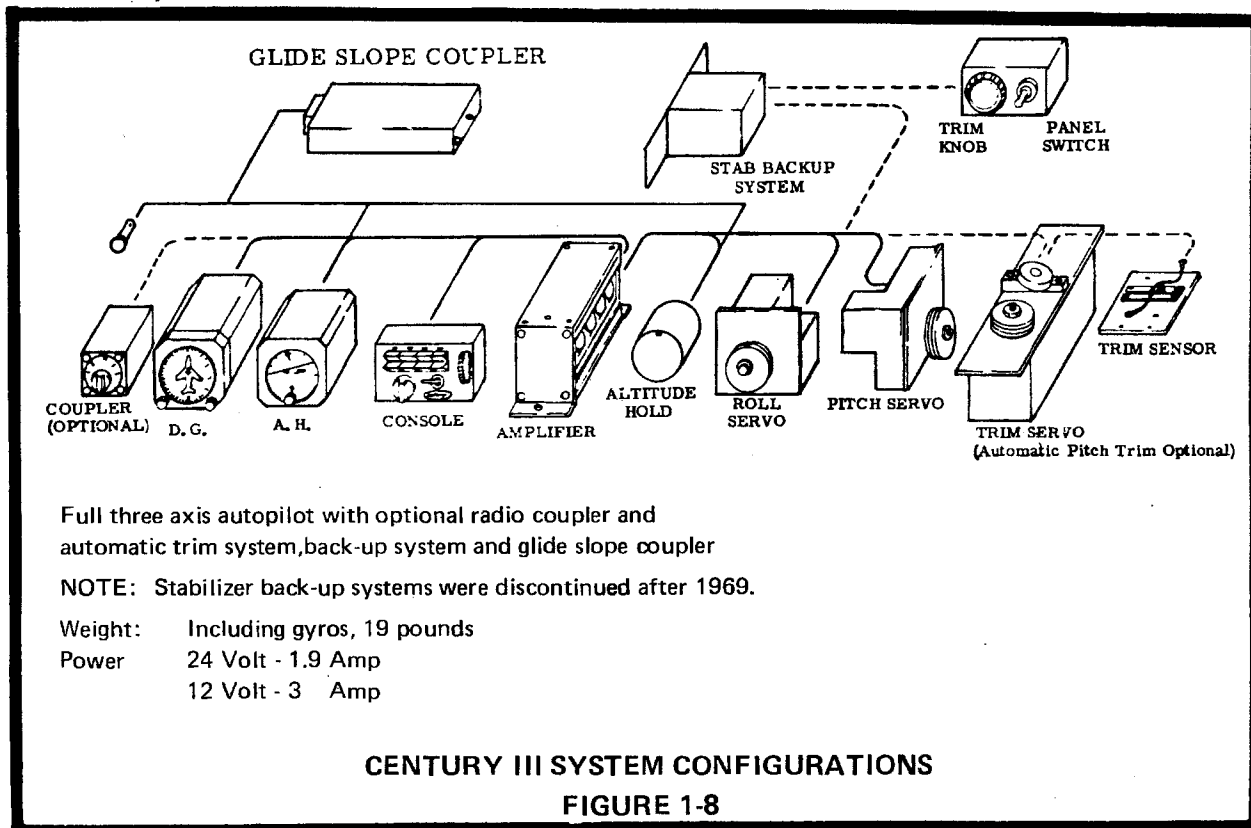

In the block diagram, (Fig. 1-9) it can be seen that the Century III is an expanded Century II system. The Century III uses the same basic circuit as the Century II in the roll section and duplicates it to form the pitch section.

Aircraft power is applied to the system through the console. The "ROLL" mode switch on the console serves two functions: When engaged it applies A+ to the system and also places the autopilot under control of the Roll Command Knob.

With A+ applied to the system, the 5 KHz oscillator within the amplifier is activated and supplies the system with a 5 KHz square wave excitation signal. This signal is virtually the "backbone" of the Century III autopilot. As can be seen in Fig. 1-9, the excitation signal is routed to the D.G. (which is a part of the oscillator since it contains the tuned circuit for the oscillator), the artificial horizon, the console and the various synchronous filters and phase detectors within the amplifier.

The D.G. uses the excitation to generate a "Heading Error Signal" or D.G. signal that tells the autopilot how far and in which direction the "heading bug" is from the gyro "Lubber Line". This signal is applied to the first AC amplifier in the roll section of the amplifier. It is switched in or out by a transistor switching circuit controlled by the roll command signal. Whenever the roll command signal is present (i.e. when the console is in "ROLL" only mode) the switch is open and therefore the D.G. signal will not be passed into the amplifier. By pressing the Heading (HDG) mode on the console, the roll command signal is removed (within the console) and the D.G. signal is allowed to pass into the amplifier.

The Artificial Horizon uses the excitation signal to generate the roll and pitch reference signals for the amplifier. These signals tell the autopilot what attitude the aircraft is in.

The console uses the excitation to generate the roll and pitch command signals. It also uses excitation to generate the roll and pitch limit and threshold signals. These signals are controlled by six screw-driven potentiometers located in the lower right corner of the console, under the face plate.

Pitch excitation is also applied to the altitude sensor to generate the altitude hold signal. This signal is active whenever the ALT mode switch is pressed on the console. The altitude hold signal replaces the pitch command signal and therefore places the pitch section of the amplifier under guidance of the altitude hold signals. In this configuration, the autopilot will cause the aircraft to maintain whatever altitude was present at the time the ALT mode switch was pressed.

The excitation signals are also used by the roll and pitch signal filters and by the optional radio coupler.

From this brief explanation, the important role the excitation signal plays in the system should be apparent. Further understanding of the 5 KHz excitation signal and its function will be related in the simplified theory of operation that follows. A more detailed explanation is provided in Section IV.

1.2.3

Signal Processing - The roll and pitch reference signals originating from the artificial horizon provide the autopilot with aircraft attitude information. In fact, they tell the autopilot what the aircraft is doing. These attitude signals are fed to summing points within the amplifier (See Fig. 1-9). When the 1D395 amplifier is used, the attitude signals may be first passed through a roll or pitch signal filter. These filters are actually rate circuits that tell the amplifier "how fast" an attitude change is occurring; therefore, they provide rate information to the autopilot. Note that a roll and pitch filter will never be used together with a 1D395 amplifier. (Design of the signal filters is such that only one may be plugged in line at a time.) (In the 1D515 and 1D515-1 amplifiers, both the roll and pitch signal filters are built-in.)

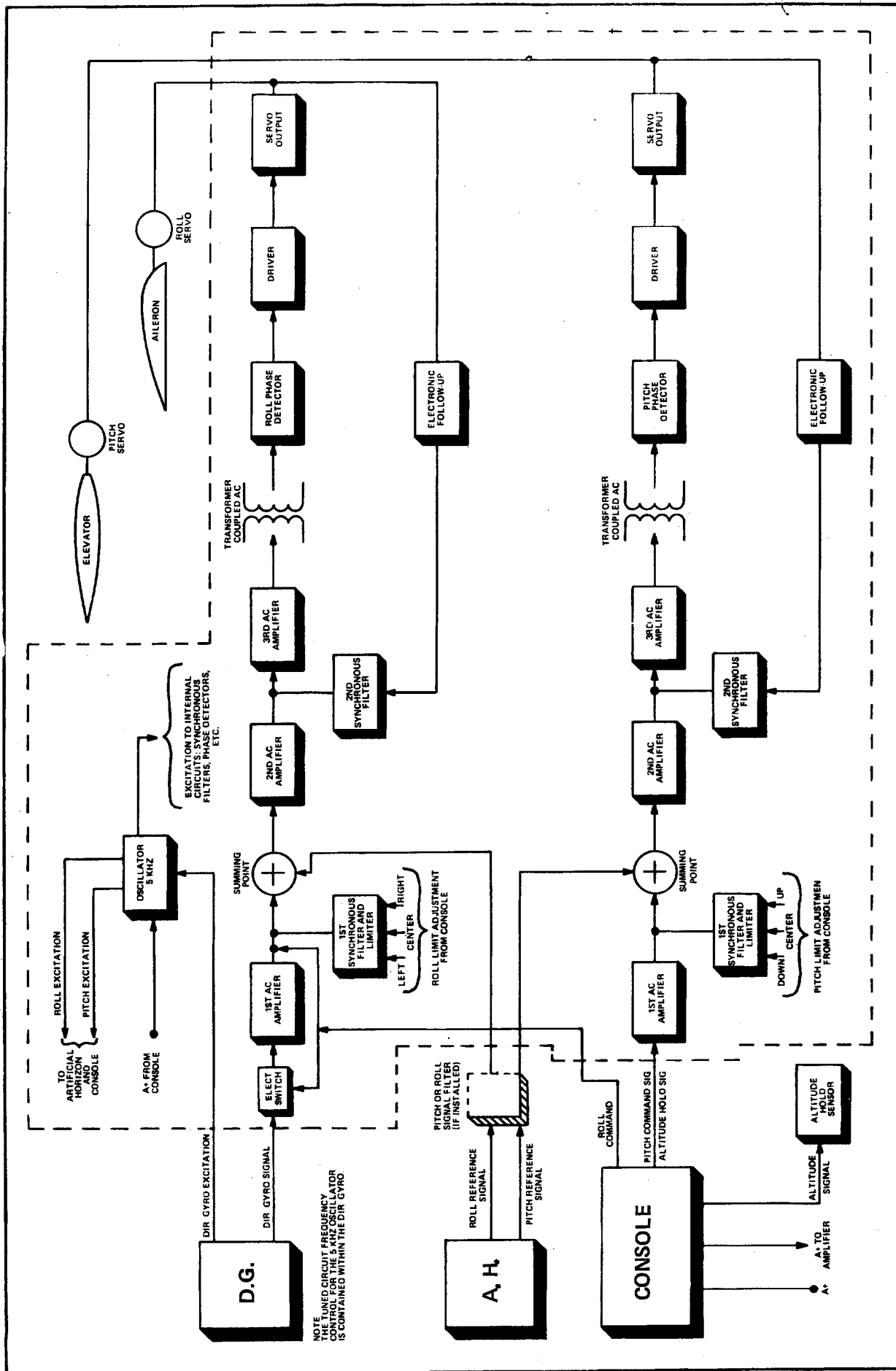

FIGURE 1-9
BLOCK DIAGRAM - CENTURY III 1D395 AMPLIFIER

With just the roll and pitch reference signals, the autopilot, if correctly adjusted, will keep the aircraft straight and level.

To command a turn or climb, the roll command and pitch command knobs on the console may be used. When the roll knob is rotated, a roll command signal is applied to the summing point in the amplifier at which time the aircraft will bank until the roll reference signal from the horizon cancels the command signal. It will stay in a bank until a different command is injected (i. e. return of the roll command knob to center position). The pitch command knob and pitch reference signal produces the same effect, but of course, controls the pitch section of the amplifier.

Depending on the mode of operation, roll and pitch command signals originate from the roll command, D. G. signal, pitch command and altitude hold signal. Regardless of which is present, the result to the summing point is essentially the same. For example, in the HDG mode, a D. G. signal will be generated when the heading bug on the D. G. is not aligned with the lubber line. In this case, the aircraft will bank in a direction that will correct the "error". In doing so, the D. G. signal will gradually decrease the bank and the autopilot will roll out the aircraft on the proper heading.

Bank limiting of the aircraft is provided by limiting the maximum amplitude of the command signal. The bank and pitch limiting of command signals are provided for in this manner before they reach the summing point. The reference signals, however, are not limited in anyway.

After the command and reference signals are mixed at the summing point, they are amplified by the second AC amplifier, processed by the second synchronous filter and amplified by the third AC amplifier. The synchronous filters throughout the amplifier serve to shape the command signals into a more perfect square wave and filter out other signal components, such as noise. After the third amplifier stage, the processed command (command + reference signal) signal is transformer coupled, to the phase detector, changed to DC, amplified by the driver and servo output, and sent to the servo motor to move the controls. A portion of the servo output signal is fed back to the electronic follow-up circuit. The output of this circuit is used to control the servo amplifier and prevent oscillation.

A complete and detailed theory of operation on the Century III is presented in Section IV of this manual. The primary objective in this presentation has been to familiarize you with a general knowledge of the parts which make up a Century III and how they are interconnected to form the autopilot system.

1.3 RADIO COUPLER

One of the optional components which may be interconnected with the Century III is the radio coupler (Fig. 1-10). This device permits guidance of the autopilot with a radio signal.

1.3.1 Basic Operation - The radio coupler is installed in line with the directional gyro and receives its power and excitation from the amplifier. In principle, the radio coupler provides a heading signal which corresponds to the direction of the course to be flown. This heading signal is coupled to a radio deviation signal in such a manner that any radio deviation will cause a proportional heading deviation.

1.3.2 Signal Processing - In Fig. 1-11, the radio coupler is broken down into block diagram form to show how the radio and heading (D.G.) signals are mixed.

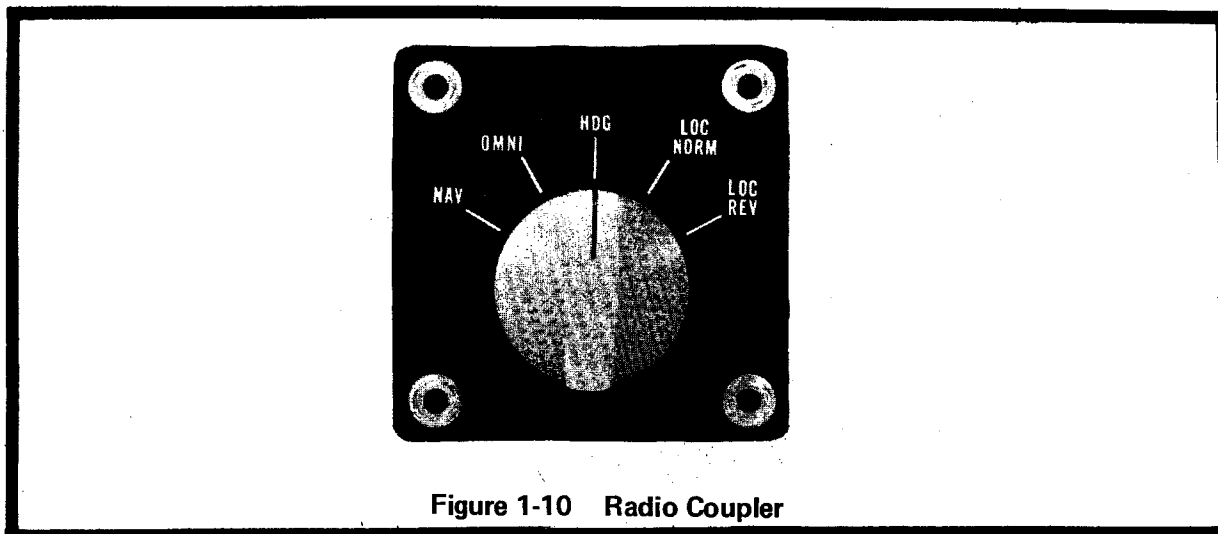

Figure 1-10 Radio Coupler

The radio signal (standard ARINC 150 mv) is applied to a chopper where it is transformed into AC and amplified. It is then coupled, through an isolation transformer, and changed back into DC by the phase detector. The DC signal is then passed on to the radio limiter circuit. Here the signal is limited to a value corresponding to 100% or full scale deviation of the omni/loc indicator. This function is part of the intercept capability of the radio coupler. However, before more is said about it, we will first track the D.G. signal's path.

The D.G. signal is transformer coupled (for isolation purposes) in the radio coupler and changed into a DC voltage by the phase detector. From the phase detector the signal is applied to two diodes and two potentiometers in parallel. This provides the necessary circuitry for establishing a crosswind capability (Ref. Fig. 1-11). The circuit is adjusted in such a manner that any D.G. signal which corresponds to 15° (approximately) of heading deviation or greater is passed. Assume that the aircraft is flying on a heading of 90° and the pilot wishes to track a radial on a course of 130° . He would set his omni course selector to 130° and set the D.G. course indicator to match. This will generate a signal from the D.G. which will be passed through one of the diodes since the deviation at this point is 40° . This D.G. signal is mixed with the limited radio deviation signal at the summing point. Remember, the radio signal is limited to a value of 100% even though the actual deviation at this point is considerably greater. As the aircraft turns in response to the heading and radio command, the D.G. will be nulled by the limited radio signal (the radio signal is opposite in polarity to the D.G. signal). At this point the aircraft will be on a heading that will intercept the radial at a 45° angle. Since the limited radio signal corresponds to 100% of deviation, the autopilot always "thinks" it is just 100% off the selected radial. Therefore, it will always seek to intercept the radial at the same angle regardless of the actual deviation beyond 100%.

When the aircraft approaches the active region of the radial (within 100% deviation) the radio signal will begin to decrease. This change causes the intercept angle to decrease. As the aircraft heading reaches 15° of the radial heading, the D. G. signal is blocked by the crosswind circuit. At this point the system is responding primarily to the radio deviation signal. If the D. G. signal was not blocked, the system would not have a crosswind capability. In this situation, the D. G. and radio signal would null at one specific point or heading—the actual aircraft heading. If a crosswind were present, the D. G. signal would prevent the aircraft from establishing any crab to compensate for the crosswind; therefore, the radio course would have to be offset to compensate for the crosswind. By blocking the D. G. signal at 15° deviation, the radio deviation signal is permitted to crab the aircraft an amount proportional to the crosswind (up to 15°) in order to keep the aircraft on course.

Short term variations in heading such as produced by turbulent air, are passed to the summing point through a high pass filter. Also a very small amount of steady state D.G. signal by-passes the filter to provide dampening.

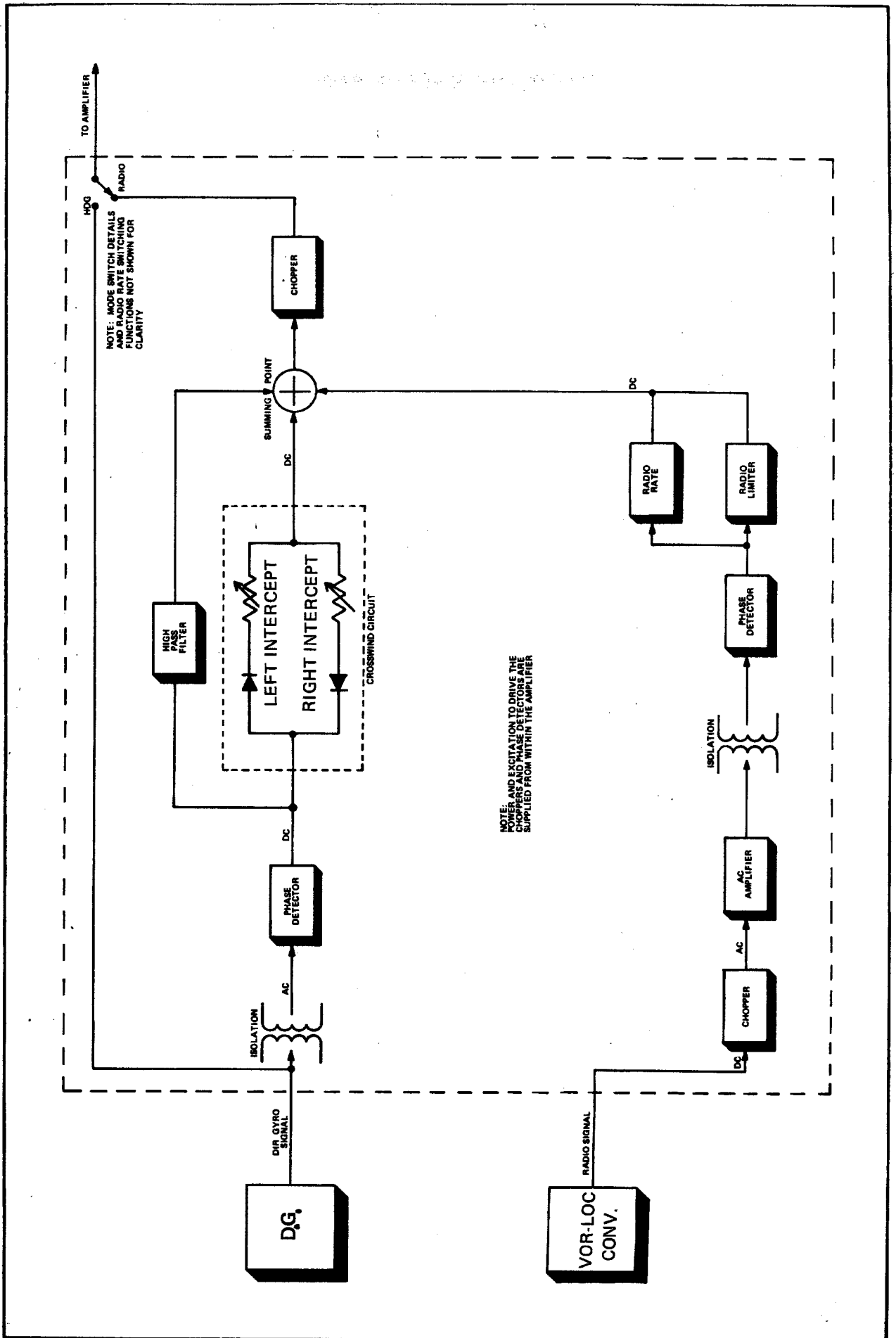

FIGURE 1-11
BLOCK DIAGRAM - RADIO COUPLER 1C388

1.4 GLIDESLOPE COUPLER (OPTIONAL)

The glideslope coupler is an automatic analog computer that directs the autopilot to intercept and track the approach glide path. This unit together with the Radio Coupler, provides a complete and automatic ILS intercept capability for the Century III autopilot.

- 1.4.1 Basic Operation - In order for the glideslope coupler to operate, three conditions must be met. First, the Radio Coupler must be set in the LOC NORM mode. Second, the console must be set in the ALT mode. Third, the glideslope deviation indicator must be deflected upward for a period of twenty seconds. This provides assurance that the glide path will be intercepted from below in the normal manner.

With these three conditions met, the glideslope coupler will arm automatically after the twenty second period.

The arming function assures that approaches to the glideslope will occur in a safe manner. For example, the LOC NORM condition prevents inadvertent coupling when flying reverse course or tracking outbound on the front course. The ALT mode condition prevents coupling from a high rate of descent and the glideslope deviation indicator condition, requiring an up deflection for twenty seconds, prevents coupling from above which could result in a very uncomfortable, if not dangerous, pitch down condition.

- 1.4.2 Signal Processing - Before the glideslope coupler can receive power, the LOC NORM mode must be switched in on the Radio Coupler. This provides the circuit ground for the glideslope coupler electronics. After the ground is established, the glideslope coupler receives a 150 mv meter signal from the aircraft's glideslope receiver. This signal is chopped, amplified and transformer coupled to a phase detector as shown in Fig. 1-42. From the phase detector, the glideslope signal is applied to the arm and engage logic switching circuits.

The arm switching circuit requires a glideslope deviation signal which is equivalent to approximately sixty percent full scale up needle deflection and a +DC altitude engage signal to activate. The sixty percent glideslope deviation signal must be present for at least twenty seconds before arming will take place.

With arming, the arm switching circuit will allow the engage switching circuit to turn on as the glideslope deviation signal reaches zero deviation. At this point, the engage switching circuit activates relay K1.

Before continuing with the function of relay K1, we will back-track and follow the path of the glideslope signal beyond the point of the arm and engage logic switching circuits. The glideslope signal at this point is split into two paths. One leads to a high gain integrator circuit and the other (steady state path) leads to a chopper. During intercept, the steady state path, through the rate circuit, is the primary controlling signal. This signal is chopped and mixed with the pitch reference signal from the horizon at T2. At this point of intercept, when K1 activates, the shunt which had been across T2, and thus preventing mixing of the glideslope signal with the pitch reference signal, is removed. Therefore, the pitch reference signal, now being applied to the amplifier will be a composite of the glideslope signal and the pitch reference signal. Effectively, the autopilot will now be commanded by a varying horizon pitch reference signal.

When glideslope intercept takes place (an instant before center needle), a preset down command is also mixed with the glideslope/pitch reference signal. The command signal provides an automatic 3 degree pitch down command to the autopilot which, along with the rate circuit, helps prevent overshoot and places the aircraft on the proper glide angle. (All glideslopes are adjusted for a no wind 3° up angle of pitch from the ground.)

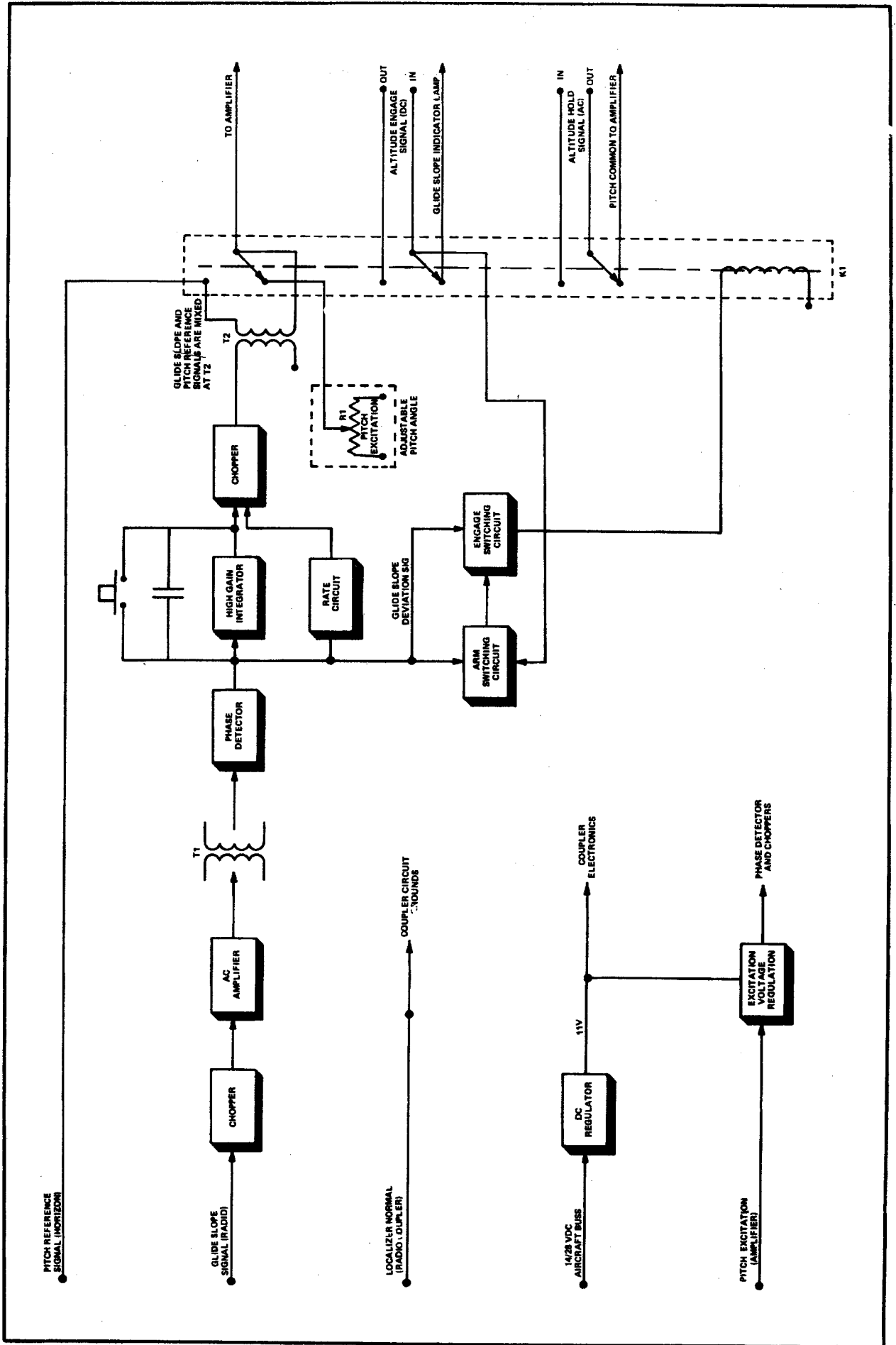
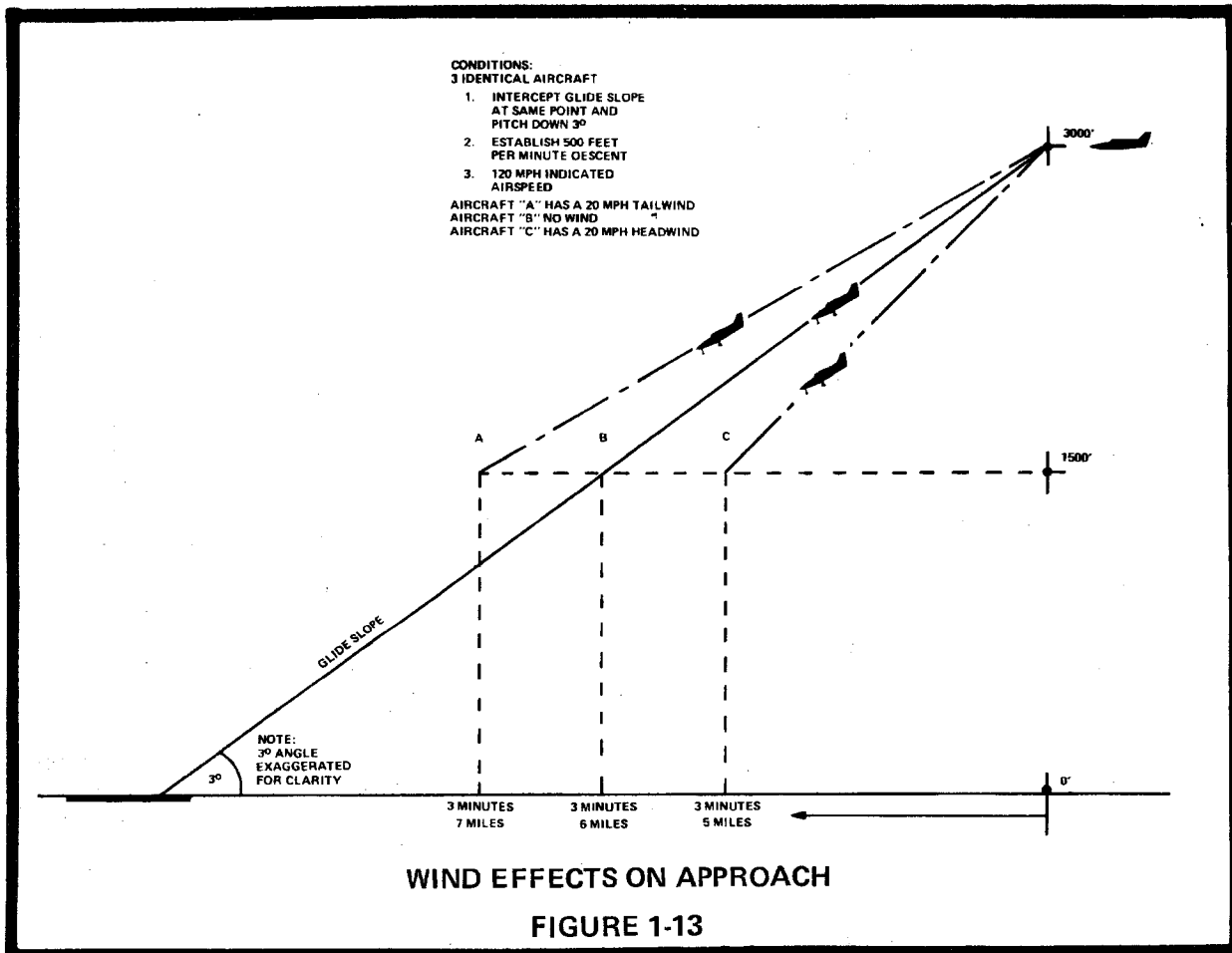

FIGURE 1-12
BLOCK DIAGRAM - GLIDE SLOPE COUPLER 1C493

The integrator circuit mentioned earlier allows the autopilot to fly the aircraft centered on the glideslope regardless of the head or tail wind conditions. Basically, this circuit is a high gain amplifier which provides additional voltage to the glideslope signal. The circuit also has a 200 MFD capacitor feedback which effectively keeps the output of the integrator from acting on short term deviations off center needle. Therefore the integrator will only provide an output when there is a constant deviation. Consider the following example:

Assume that an autopilot without an integrator has intercepted the glideslope and is coupled. A strong headwind is present and the autopilot, due to the headwind, cannot maintain center needle. Instead, some point slightly below center is achieved.

To understand this, refer to Fig. 1-13. In this illustration the path of the aircraft at a fixed 3° angle of descent is shown in a strong headwind condition as compared to a zero wind condition. (Remember that the aircraft is set to approximately 3° pitch down automatically upon glideslope intercept. To the autopilot, this represents the correct attitude on the glideslope). It can be seen that with a strong headwind the aircraft would reach the ground at a much shorter distance than under zero wind conditions. Thus it would undershoot the approach. The electronics of the autopilot together with the glideslope signal, of course, would not allow undershoot to this degree. However, since the preset 3° pitch down command represents the correct attitude, this signal would continuously oppose the glideslope signal which is telling the autopilot that it is below center glideslope. The result is an electronic averaging. This average command would place the aircraft slightly below center needle. Therefore, the aircraft would track the glideslope parallel but slightly below center.



The integrator prevents off center tracking by sensing any constant deviation of the glide slope signal. It allows approximately 10 to 15 seconds to pass before acting upon the signal. In this way short term deviations caused by rough air will not cause an output from the integrator. With long term deviation, however, the integrator provide an additional signal which is mixed with the glide slope signal. The resultant signal corrects the deviation and allows tracking of the glide slope without needle off-set.

In Fig. 1-12, a push button switch is shown across the integrator circuit. This button is located on one end of the glideslope coupler and is used during flight adjustment. It effectively shorts the integrator while adjusting the pitch or glideslope angle. Also note that the integrator is shorted prior to intercept of the glideslope. This is accomplished through a set of contacts on relay K1 (not shown in Fig. 1-12). This assures that the integrator will not provide a false output at the point of intercept.

1.5 STABILIZER SYSTEM AND OMNI TRACKER

1.5.1 Description - The stabilizer system is a yaw and roll axis stabilizer which is capable of performing short term heading hold as well as omni navigation course functions. It may also be used as a stabilizer back-up option, providing a "standby" system to maintain the yaw and roll modes of flight with the Edo-Aire Mitchell Century II and III autopilots.

Its principal components are a rate gyro and servo amplifier combined, a small panel mounted on-off switch, a panel mounted azimuth trim switch, a control wheel mounted azimuth disconnect switch and an aileron servo assembly. See Fig. 1-14.

1.5.2 Basic Operation - The rate gyro used in the stabilizer has only one gyro wheel. It is inclined at a 45° angle (with reference to the fore and aft center line of the fuselage) which permits sensing in both the yaw and roll axis. The rotating gyro wheel is retained by a moveable gimbal which is centered by a pair of calibrated springs. A metal vane attached to the moveable gimbal changes the flux gap of an electrical pickoff to provide gyro error signals, which are sent to the servo amplifier.

The electronic gyro-amp accepts the error signals from the rate gyro and through the process of mixing and comparing like and unlike voltages determines the DC polarity and how much of the corrective signal shall be fed to the aileron servo motor. See Fig. 1-15.

The servo motor is a geared, DC, electrically reversible motor, which is engaged or disengaged to a cable capstan by a solenoid operated idler gear. The cable capstan has a short length of aircraft control cable (commonly called a bridle), wrapped around it, usually one or more turns, with the ends mechanically fastened to the aircraft control cables.

Therefore, the rotational torque generated at the capstan is transmitted to the aircraft control cables.

The omni tracker is an option which can be plugged into the stabilizer system which permits radio navigation course functions. The same signal that is generated by the omni converter to move the course needle is used by the electronic radio tracker. The processed omni signal is summed with the rate gyro signal in the servo amplifier to drive the aileron servo motor. This maintains the aircraft on an omni radial. See Fig. 1-14.

When used as a stabilizer back-up option, a small relay changeover box is added to the installation. This relay box is usually remotely located and contains the relay which automatically engages the stabilizer system when the autopilot system is in the "OFF" position and the back-up system switch is in the "ON" position.

When installed as an autopilot back-up system, the stabilizer uses the same roll (aileron) servo as installed with the autopilot and requires no additional servo.

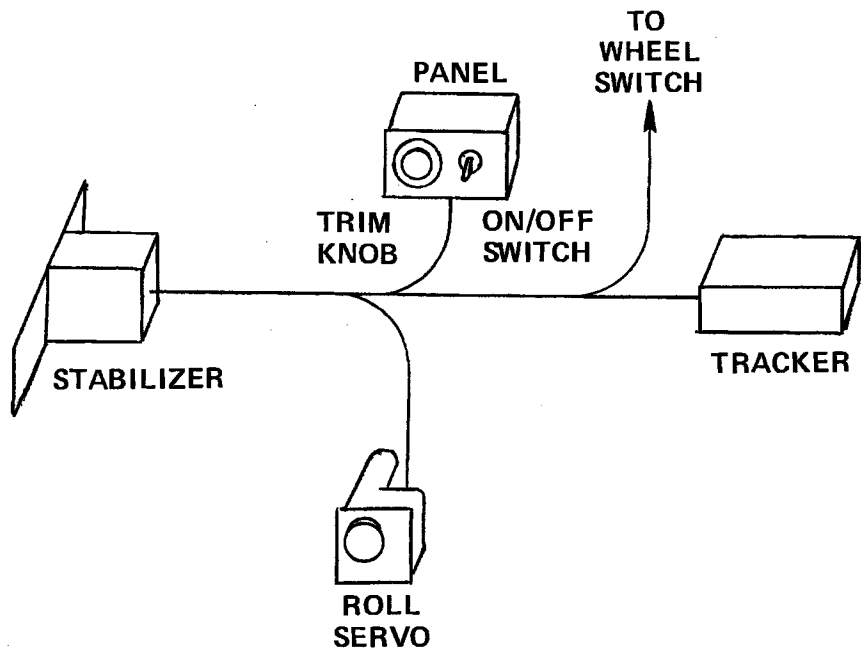

STABILIZER/TRACKER SYSTEM
FIGURE 1-14

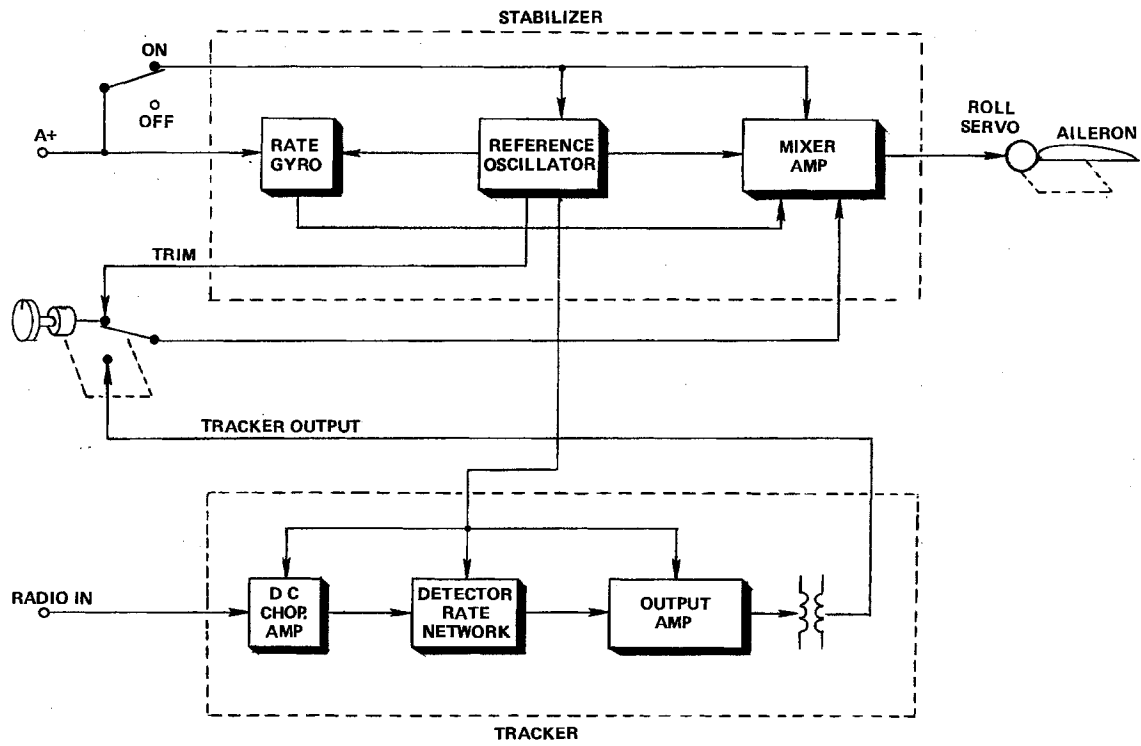

BLOCK DIAGRAM - STABILIZER/TRACKER
FIGURE 1-15

1.6 AUTOMATIC TRIM SYSTEM

1.6.1 Description - The automatic trim system provides an automatic means of positioning the pitch control trim system to relieve the pilot or autopilot of pitch change pressures.

When an aircraft is placed in a climb or descent configuration, or a power change is initiated, (and on some aircraft as fuel is consumed), an attitude change occurs. This causes a deflection of the control surfaces into the moving slipstream, which creates a force that is fed back through the control column to the pilot. To relieve this control pressure, the pilot activates a trim sensor switch mounted on the control wheel which enables the automatic trim system to operate, thereby reducing the fatigue of the pilot. When the Century III autopilot is "ON" (pitch mode), the automatic pitch trim system is in constant operation and no special manipulation is required by the pilot. This provides another added bonus! When the autopilot is switched "OFF" it always hands the aircraft back to the pilot in a "Trimmed" condition.

1.6.2 Basic Theory of Operation - The automatic pitch trim system consists of three basic units, a trim sensor, a pitch trim servo amplifier, and a pilot's wheel mounted control switch. See Fig. 1-16.

The trim sensor is an assembly consisting of a fixed mounting plate with two adjustable contacts and a sliding or rotating bar with a common contact, which is attached to pulleys that ride on the "UP" and "DOWN" elevator cables. Cable tension operates the moveable portion of the trim sensor which initiates appropriate trim action. See Fig. 1-17. Since both types of sensor assemblies work by the same principle, only the sliding bar type, (the most common) will be used for the example.

The pitch trim servo and amplifier are normally installed on the same mounting bracket. See Fig. 1-18. The pitch trim servo is a geared, DC, electrically reversible motor. The servo capstan has a short length of aircraft control cable (bridle) wrapped around it with the ends mechanically fastened to the trim control cables. Therefore, the rotational torque generated at the servo capstan is transmitted to the trim cables.

The pitch trim amplifier supplies the operating power for the servo. It is a dual sided amplifier, one side of which runs the servo motor in a clockwise direction; the opposite side runs the servo motor in a counterclockwise direction.

The contacts on the trim sensor merely determine which side of the dual amp will operate, and for how long, thereby causing the servo motor to run in the desired CW or CCW direction and for the proper amount of time.

The pilot's wheel mounted switch is usually installed in the left side of the control wheel and can be operated with the left thumb. The pilot uses this switch to trim out the control forces when the autopilot is not engaged.

Since the trim sensor works on the principle of "Tension" on the control cables, an understanding of how that tension is applied to and removed from the controls is necessary. The pilot or autopilot, applies it by moving the control yoke fore or aft. This displaces the elevator or pitch control into the moving slipstream. This is perfectly normal and is the pilot's way of controlling or making the aircraft do what he wants.

There are two control cables connected between the control yoke to the elevator or pitch control. Both cables will be pulled respectively for "UP" or "DOWN" deflection of the elevator or pitch control. Obviously, you can not push on a flexible cable and get any work out of the other end.

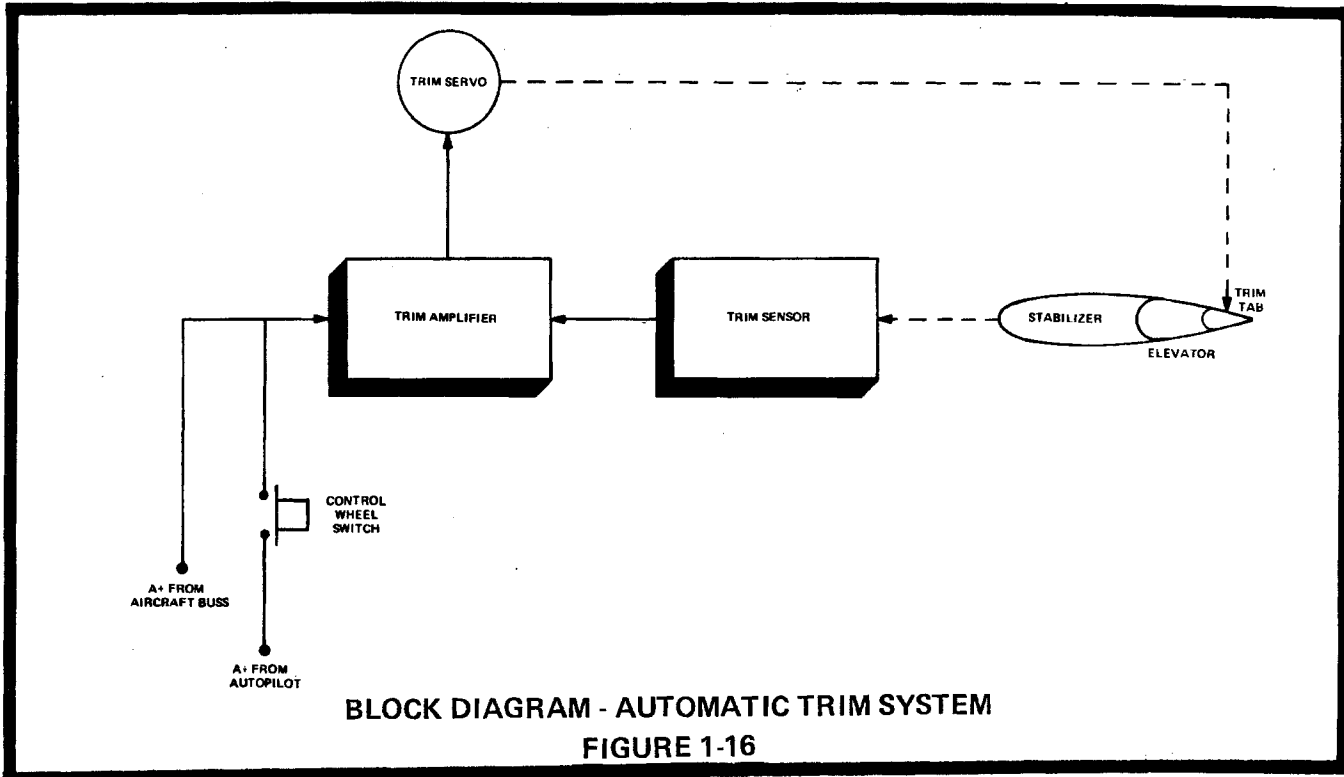

When the pilot pulls the control yoke aft, the control cable is pulled that will deflect the trailing edge of the elevator "UPWARD" into the slipstream. The slipstream immediately tries to return the deflected control surface to a neutral or "Streamlined" position, which it will do unless the pilot holds aft pressure (pulls) on the control column with an equal force that will maintain the control surface in its deflected condition. It is this pulling on the control cable which places it under tension. The opposite (down) control cable will not have tension on it, at this time, as it is not performing any work. In fact, under the above conditions, it could be removed however, when the situation is reversed, it will be needed for the downward pull.

On long cross country flights, the continuous effort of constant pressure on the control column is very tiring for the pilot. To minimize the fatigue problem and to aid in aircraft control, trim tabs are used. They are a small auxiliary control or portion of a primary control which is hinged and built into or mounted on the primary control. In this case, it will be used for pitch trim. It is the trim tabs that remove the "tension" from the aircraft control cables. The trim tabs work by the very same principle as the elevators. They are deflected into the slipstream by the pilot. However, they are not a free floating type of control. Once they are positioned by the pilot or the pitch trim servo, they will remain in that position until moved again by the pilot or automatic trim. They are not connected to the control yoke, but are usually operated by a small hand wheel or crank and aircraft cables (trim cables). They cannot streamline themselves and must be manually operated both ways.

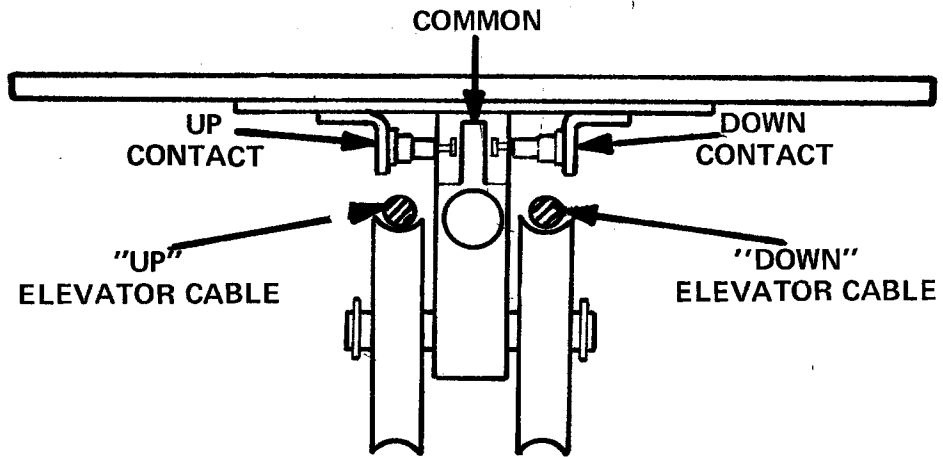

(A)

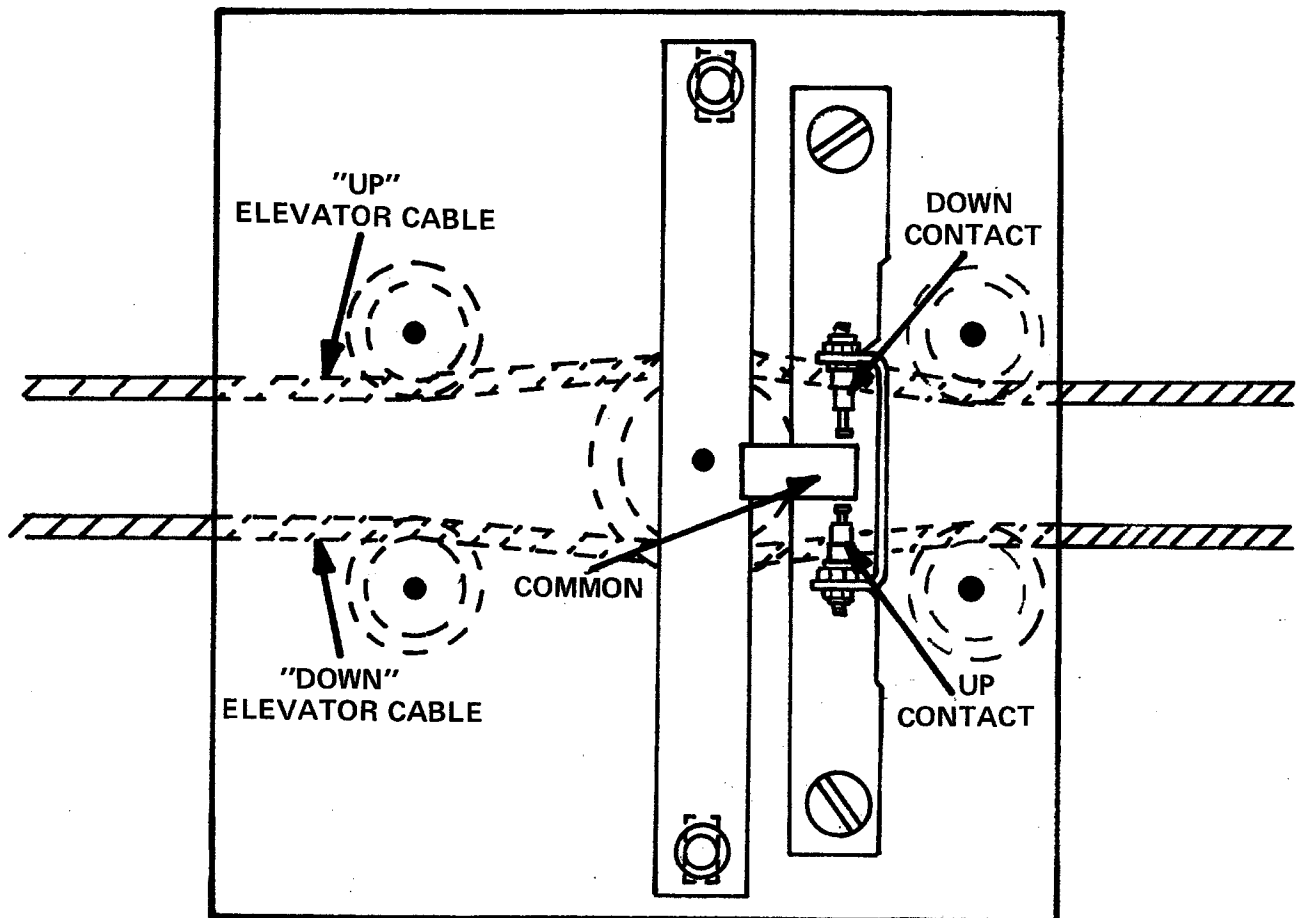

(B)

TYPICAL TRIM SENSORS
FIGURE 1-17

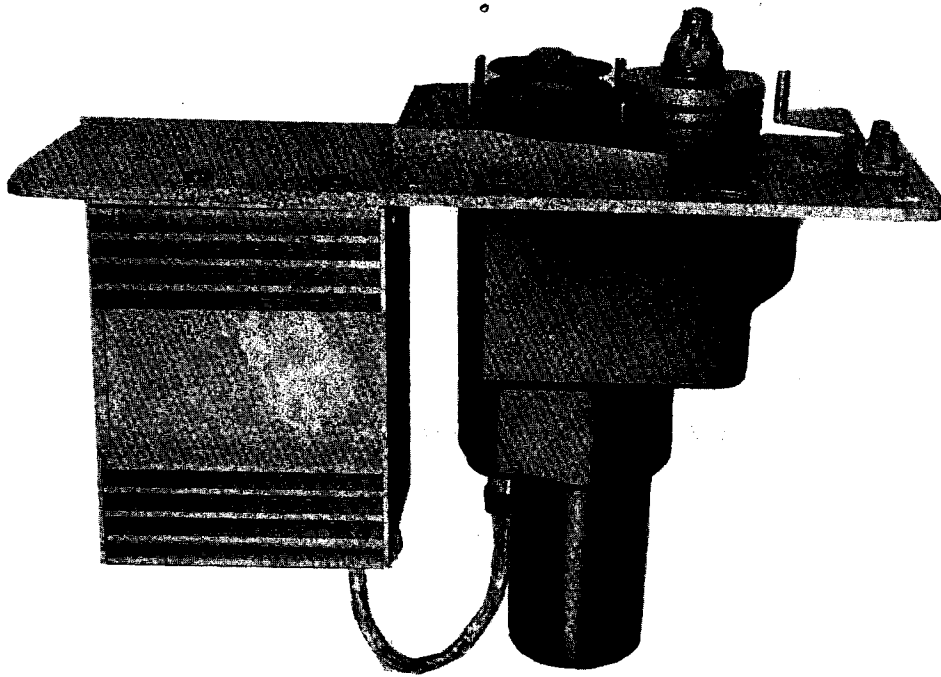

TYPICAL TRIM SERVO AND AMPLIFIER
FIGURE 1-18

Once the pilot deflects a trim tab, the slipstream immediately tries to streamline or neutralize it. Not being free to rotate about its hinge or pivot point, it must move in an up or down direction striving to streamline itself. As it is mechanically attached to the trailing edge of the elevator, it is carried "UP" or "DOWN" by the trim tab's action. As the trim tab is deflected more and more into the slipstream, the greater the "UP" or "DOWN" travel of the elevator. Just as an elevator or pitch control flies an aircraft up or down, a trim tab flies an elevator up or down. See Fig. 1-19.

Therefore, a properly adjusted trim tab can "fly" the elevator into the desired deflected position and maintain it there. As the trim tab has now assumed the entire workload, it has removed the tension from the "pulled" elevator control cable and control yoke.

Now that the principle of applying and removing tension to a control cable has been reviewed, it can be applied to the trim sensor. With the elevator surface in a neutral or streamlined position, both elevator control cables will have equal tension. In this position, the common contact and sliding bar assembly of the trim sensor will be in the "Neutral" position and no trim signal will be generated. See Fig. 1-17(b)

When the elevator is deflected upward, the moving slipstream tries to force it back into the neutral position. This force creates a greater tension on the "UP" elevator cable which causes the sliding bar and its contact to slide upward, making contact with the fixed up command contact. See Fig. 1-20.

This energizes one side of the servo-amp causing it to energize the servo, which begins to move the trim tab in the proper direction. The servo will continue to run until the trim tab is deflected sufficiently to relieve the tension on the up control cable. At this time the sliding bar and its contact will move back to its center or neutral position. This breaks the circuit to the servo-amp which also stops the servo and trim tab.

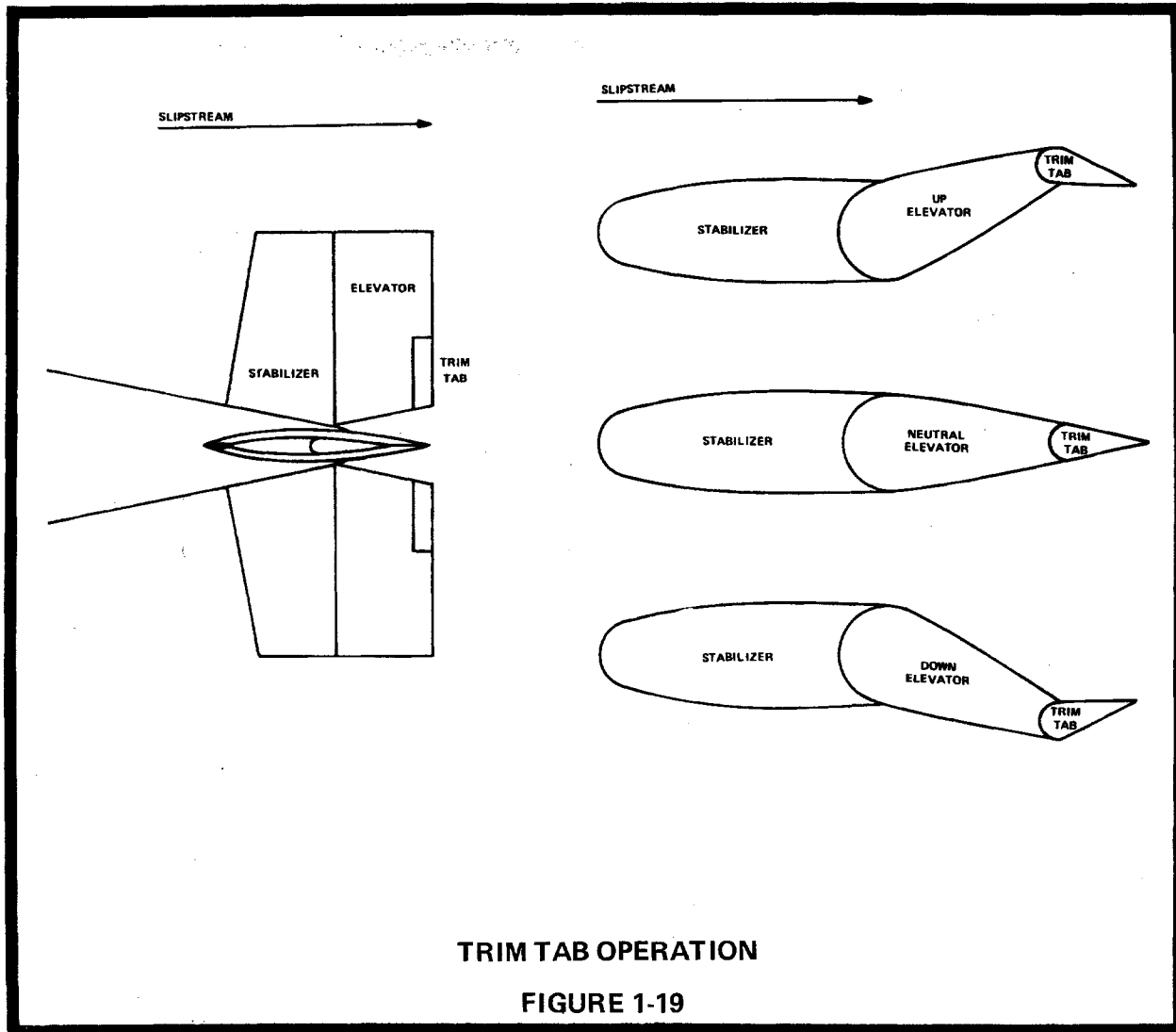

TRIM TAB OPERATION

FIGURE 1-19

When the elevator is deflected downward, the same sequence of events occur. However, the down command and common contacts now energize the opposite side of the servo-amp and the servo runs in the opposite direction. See Fig. 1-21.

Remember! When the autopilot is engaged, the automatic trim system is fully automatic and working 100% of the time.

When the autopilot is off, the automatic trim system will not work until the pilot depresses his control wheel mounted trim switch. The pilot manually positions the control yoke to his desired position, then depresses his trim switch which now supplies the power for the automatic trim system. Once the power has been supplied, the system works exactly as before. When the control forces have been neutralized, the pilot merely releases his trim switch. He can trim the aircraft as often as desired by pressing and releasing his trim switch.

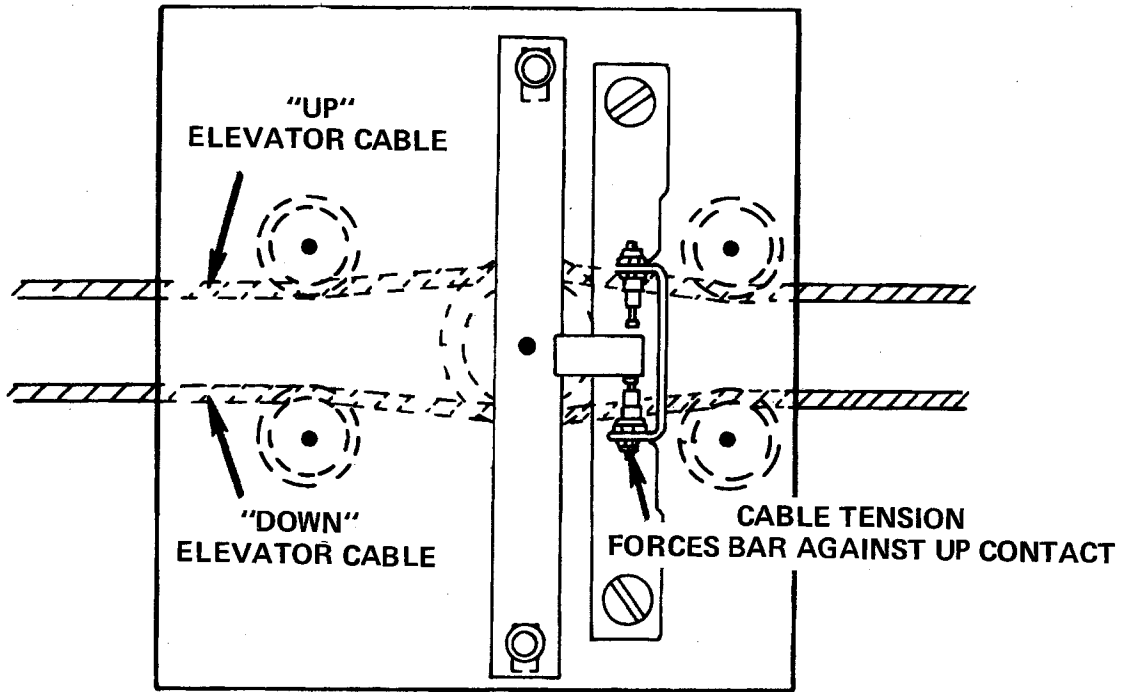

TRIM SENSOR IN "UP ELEVATOR" CONDITION

FIGURE 1-20

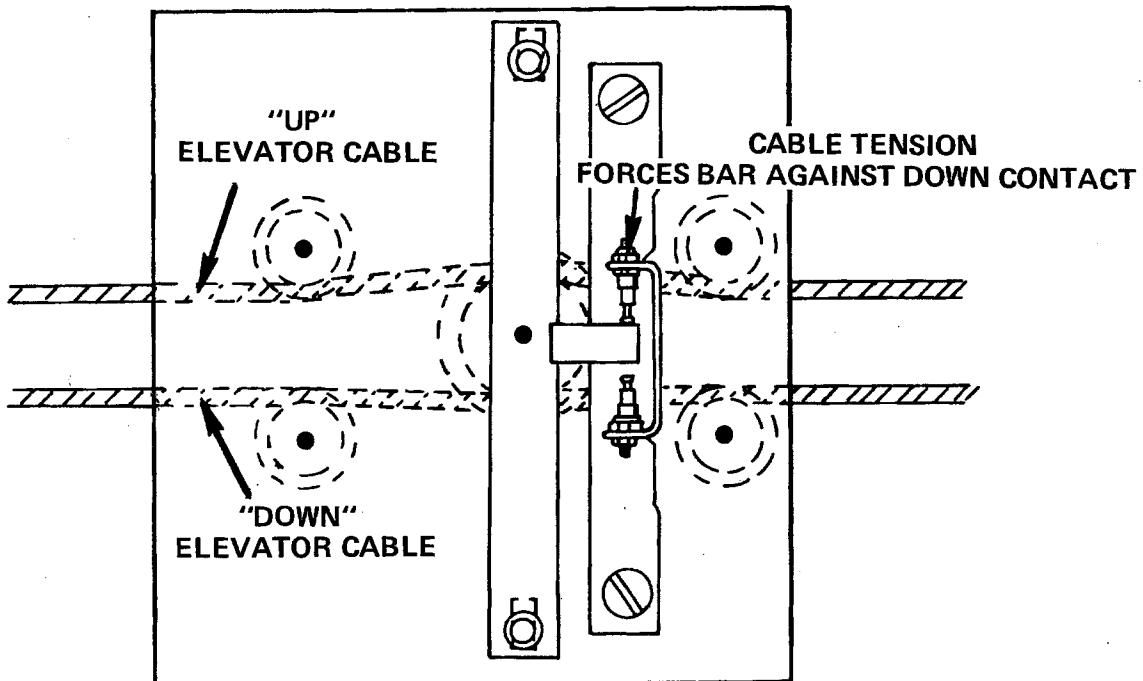

TRIM SENSOR IN "DOWN ELEVATOR" CONDITION

FIGURE 1-21

SECTION II

AUTOPILOT INSTALLATION DATA

The following section contains a parts description, nomenclature and location for each supplemental type certificate (STC) held by Edo Avionics for the Century II and III autopilots. This section is arranged alphabetically according to airframe manufacture and then numerical within a specific manufacture according to aircraft model. An index of manufacturers is provided on the following page.

In addition to the above mentioned information, the data sheets also contain servicing data which include servo clutch settings, trim sensor joint settings and bridle cable part numbers.

At the top of each data page the aircraft manufacturers name, the system (Century II or Century III), the autopilot kit (AK) and STC numbers and the model(s) covered by the STC are listed. To the left of this page is an outline drawing of the listed aircraft. The circled numbers show location of the various autopilot components and correspond to the numbers in parenthesis under the LOCATION column on the data page.

INDEX

AERO COMMANDER-	—	—	—	—	—	—	—	—
AEROSTAR—	—	—	—	—	—	—	—	—
AMERICAN AVIATION	—	—	—	—	—	—	—	—
BEECHCRAFT-	—	—	—	—	—	—	—	—
BELLANCA —	—	—	—	—	—	—	—	—
BRITTEN—NORMAN-	—	—	—	—	—	—	—	—
CESSNA- —	—	—	—	—	—	—	—	—
DEHAVILLAND	—	—	—	—	—	—	—	—
HELIO- —	—	—	—	—	—	—	—	—
MAULE -	—	—	—	—	—	—	—	—
MOONEY	—	—	—	—	—	—	—	—
PIPER—	—	—	—	—	—	—	—	—
WREN—	—	—	—	—	—	—	—	—

AK293

AERO COMMANDER 100/180

AERO COMMANDER

CENTURY II

AK293
STC SA1080SW

AERO COMMANDER 100/180

PART DESCRIPTION AND NOMENCLATURE	LOCATION
CONSOLE-AMPLIFIER 1C385	(1) Instrument panel
ARTIFICIAL HORIZON 52D66	(1) Instrument Panel
DIRECTIONAL GYRO 52D54	(1) Instrument panel
ROLL SERVO 1C363-293R	(3) Under floor, pilot's side, first bay aft of wing strut attach point.
MAIN CABLE HARNESS 30C198	
RADIO COUPLER (OPT.) 1C388	(1) Instrument panel

SERVICING DATA

Roll Servo Clutch Setting (lbs): 35 ± 5

Pitch Servo Clutch Setting (lbs):

Pitch Trim Servo Clutch Setting (lbs):

Trim Sensor Point Gap (in.):

Bridle Cable(s): Roll - 30B221

Limitations Placard Part Number: 13A344-293

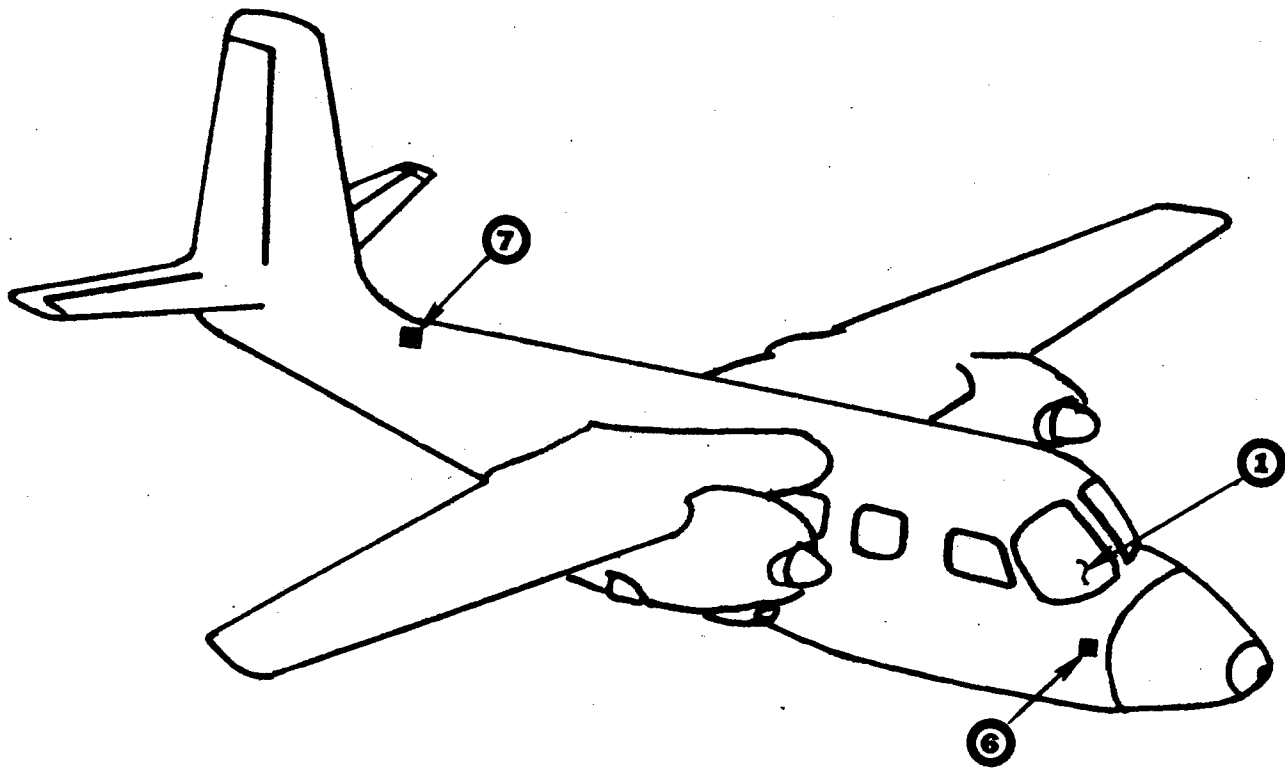
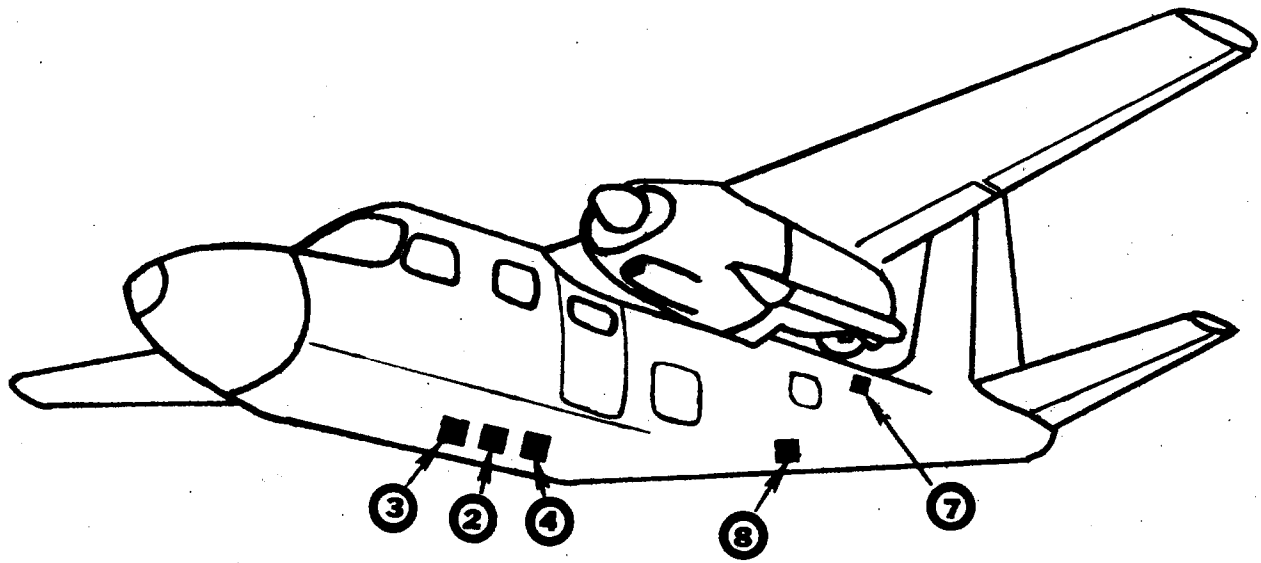

AK221
AK353

AERO COMMANDER 500A, 500B, 500U, AND 500S

AERO COMMANDER

CENTURY III

AK221
STC SA680SW

AERO COMMANDER 500A, 500B, 500U, AND 500S

PART DESCRIPTION AND NOMENCLATURE	LOCATION
ROLL SIGNAL FILTER 1B440	(1) Under instrument panel near artificial horizon
CONSOLE 1C404	(1) Lower portion of pedestal
ARTIFICIAL HORIZON 52D67	(1) Instrument panel
DIRECTIONAL GYRO 52D54	(1) Instrument panel
ROLL SERVO 1C465-1-221R	(3) Under inspection plate in center floorboard
PITCH SERVO 1C470-1-221P	(4) Under center floorboard, just aft of roll servo
ALTITUDE HOLD 1C4071	(6) On forward cabin bulkhead above air duct, right side (middle)
MAIN CABLE HARNESS 30D207-6	
RADIO COUPLER 1C388	(1) Instrument panel
TRIM SERVO 1C469-1221	(7) Just forward of Station 252.0 in aft fuselage at top
TRIM SENSOR 1C365-221	(8) Mounted at bulkhead station 198 at bottom of aft fuselage, center
TRIM SWITCH 40S45	Left side of pilot's control wheel
AMPLIFIER 1C515-1 OR 1C395	(2) Under floorboard between roll and pitch servos
NOTE: AK353 SA1394SW with Command/Electric Trim	

SERVICING DATA

Roll Servo Clutch Setting (lbs): 35 ± 5
 Pitch Servo Clutch Setting (lbs): 20 ± 2
 Pitch Trim Servo Clutch Setting (lbs): 20 ± 2
 Trim Sensor Point Gap (in.): $.010 \pm .002$
 Bridle Cable(s): Roll - 30B262. Pitch - 30B263
 Limitations Placard Part Number: See AFM Supplement

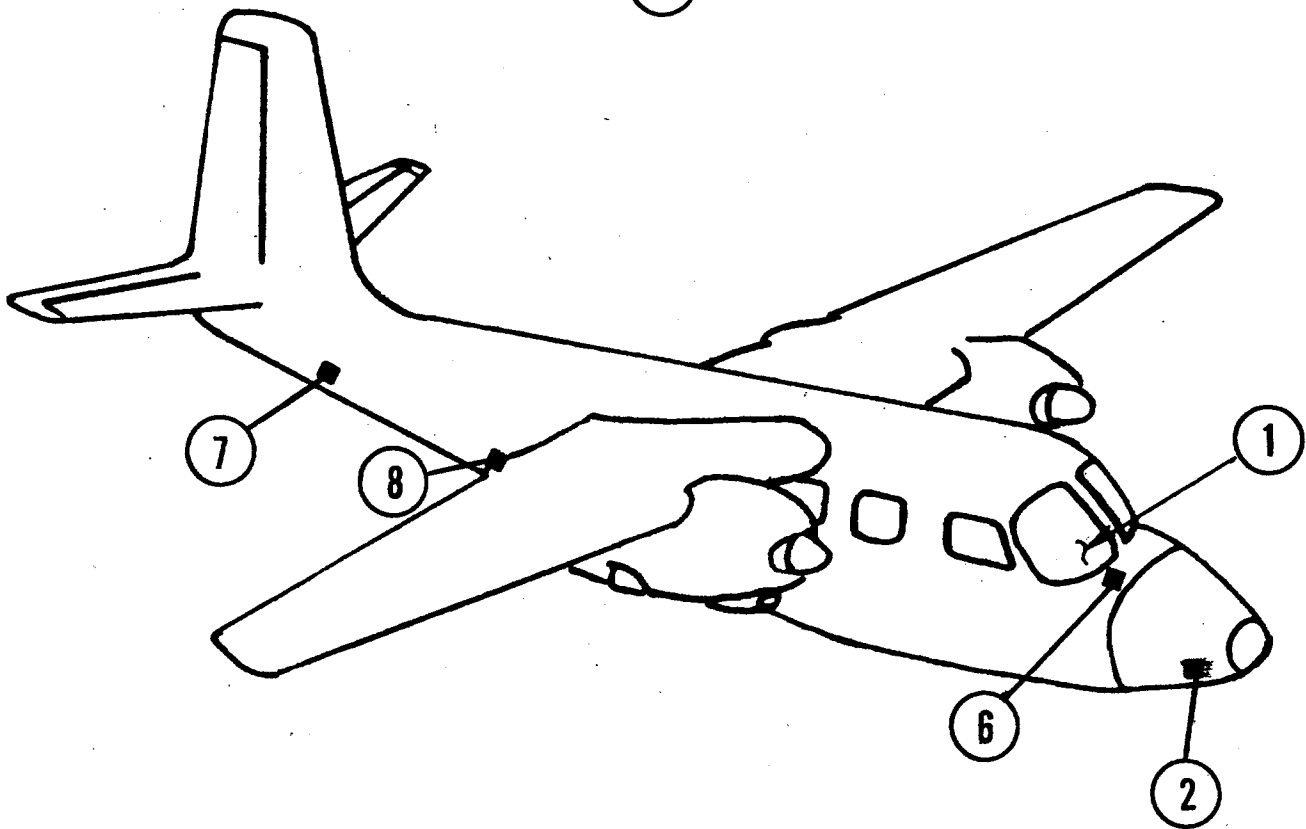
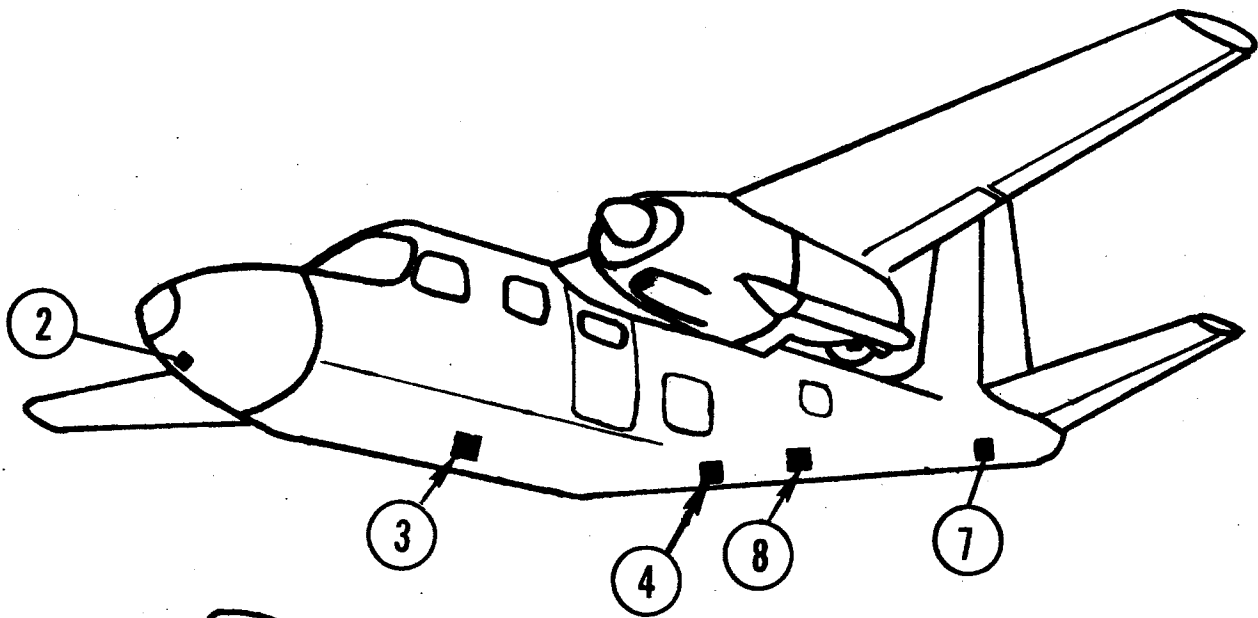

AK270

AERO COMMANDER 680 FL

AERO COMMANDER

CENTURY III

AK270
STC SA929SW

AERO COMMANDER 680FL

PART DESCRIPTION AND NOMENCLATURE	LOCATION
CONSOLE 1C404 ARTIFICIAL HORIZON 52D67 DIRECTIONAL GYRO 52D54 ROLL SERVO 1C465-1-270R PITCH SERVO 1C470-1-270P ALTITUDE HOLD 1C407 MAIN CABLE HARNESS 30D207-7 RADIO COUPLER 1C388 TRIM SERVO 1C469-1-270 TRIM SENSOR 1C365-270 TRIM SWITCH 40S45 AMPLIFIER 1C515	(1) Lower portion of pedestal (1) Instrument panel (1) Instrument panel (3) Under floor between pilot's seats (4) Under floor just aft of Station 178.812. Remove center floor panel in baggage compart. (6) On forward cabin bulkhead on top of air duct, on right side of A/C C/L (1) Instrument panel (7) Aft of fuselage on A/C C/L, just forward of Station 328.0 at top of fuselage (8) At bulkhead Station 254.0 at bottom of fuselage on A/C C/L Left side of pilot's control wheel (2) Forward of Station 5.50, lower section right side in radar compartment

SERVICING DATA

Roll Servo Clutch Setting (lbs): 35 ± 5
 Pitch Servo Clutch Setting (lbs): 20 ± 2
 Pitch Trim Servo Clutch Setting (lbs): 20 ± 3
 Trim Sensor Point Gap (in.): $.010 \pm .002$
 Bridle Cable(s): Roll - 30B262 Pitch - 30B263
 Limitations Placard Part Number: See AFM Supplement

AK374

AMERICAN AA-5 TRAVELER

AMERICAN AVIATION

CENTURY II

AK374
STC SA1486SW

AMERICAN AA-5 YANKEE

PART DESCRIPTION AND NOMENCLATURE	LOCATION
CONSOLE-AMPLIFIER 1C385	(1) Instrument panel
ROLL SIGNAL FILTER 1B440	(1) Near artificial horizon
ARTIFICIAL HORIZON 52D66	(1) Instrument panel
DIRECTIONAL GYRO 52D54	(1) Instrument panel
ROLL SERVO 1C363-1-373R	(3) On lower end of control yoke support bracket, directly below fuel selector valve, on A/C C/L
MAIN CABLE HARNESS 30C198	
RADIO COUPLER (OPT.) 1C388-M	(1) Instrument panel

SERVICING DATA

Roll Servo Clutch Setting (lbs): 20 ± 3

Pitch Servo Clutch Setting (lbs):

Pitch Trim Servo Clutch Setting (lbs):

Trim Sensor Point Gap (in.):

Bridle Cable(s): Roll - 30B200

Limitations Placard Part Number: 13A344-374

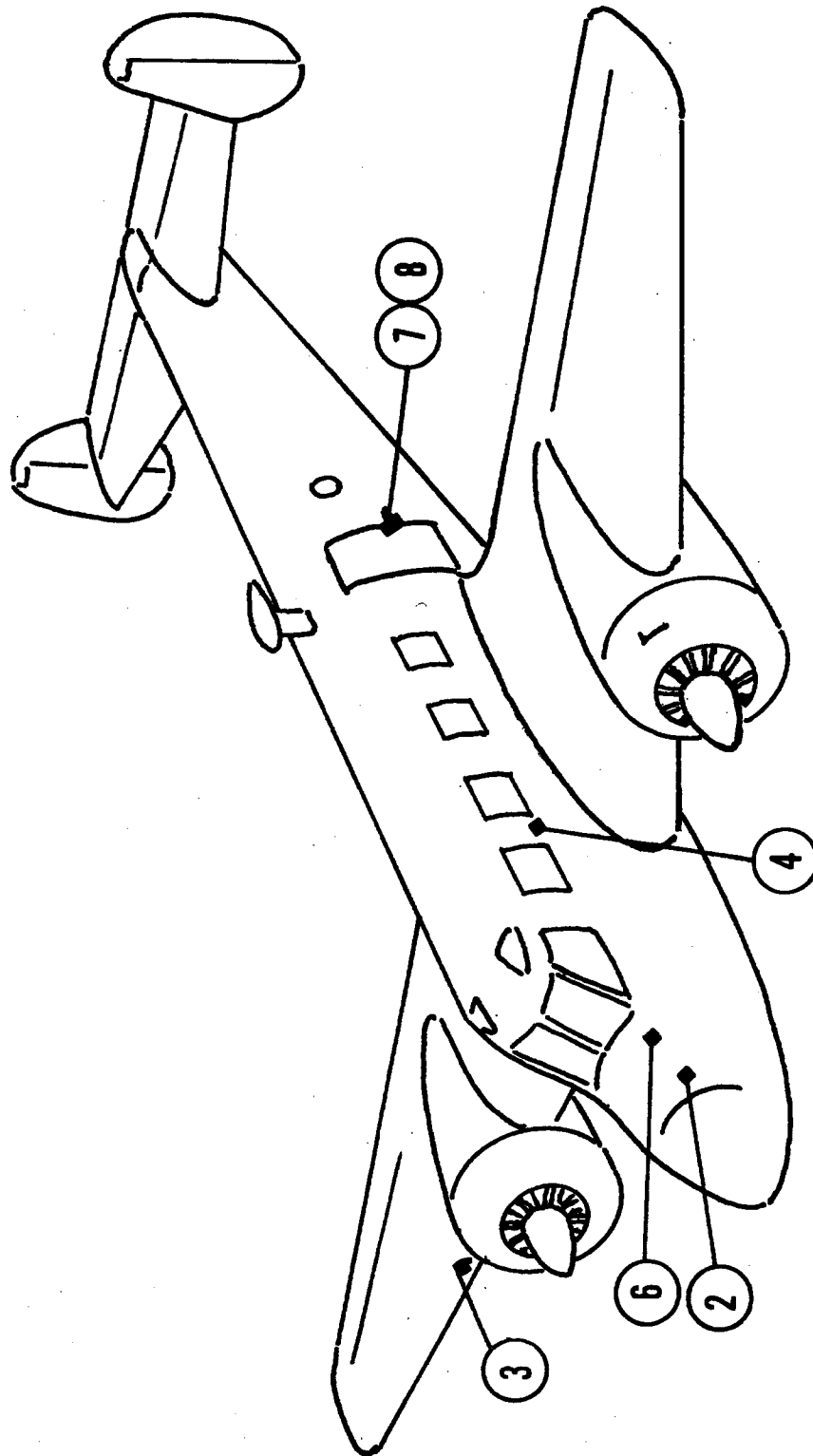

AK235 BEECH JRB-6, TC45-J(SNB-5), D18C, D18S, E18S, C45G, C45H,
TC45H, TC45G, RC45J, E18S-9700, G18S, H18, 3N, 3NM,
3TM

CENTURY III

AK235
STC SA745SW

BEECH JRB-6, D18C, D18S, E18S-9700,
G18S, H18, C-45G, C45-H, TC-45H, TC45-G
and TC-45J (SNB-5)*

PART DESCRIPTION AND NOMENCLATURE	LOCATION
ROLL SIGNAL FILTER 1B440	(1) Under instrument panel near artificial horizon
CONSOLE 1C404	(1) On pedestal beneath throttle quadrant
ARTIFICIAL HORIZON 52D67	(1) Instrument panel
DIRECTIONAL GYRO 52D54	(1) Instrument panel
ROLL SERVO 1C414-235R	(3) Just outboard right engine at rib No. 2 and forward of main spar (taxi light inspection door)
PITCH SERVO 1C470-252P	(4) Underneath floorboard on centerline, between first and second bulkhead ring aft of main spar
ALTITUDE HOLD 1C407	(6) On forward cabin bulkhead or on angle brace, between instrument panel and forward cabin bulkhead, pilot's side
MAIN CABLE HARNESS 30D207-4	
RADIO COUPLER 1C388-()	(1) Instrument panel
GLIDE SLOPE COUPLER 1C493	(1) Behind instrument panel within 3 feet of artificial horizon
G.S. COUPLER HARNESS 30C291	
TRIM SERVO 1D368-235	(7) Under baggage compartment floor of A/C C/L
TRIM SENSOR 1D486-235	(8) Under baggage compartment floor with trim servo on A/C C/L
TRIM SWITCH 30B192	Pilot's control wheel
AMPLIFIER 1D395	(2) On aircraft radio rack in nose section of aircraft
*Model RC45J when modified per Beech Drawing 404-001100 and 3N, 3NM and 3Tm when modified per Beech Drawing 18-5011.	

SERVICING DATA

Roll Servo Clutch Setting (lbs): 55 ± 3
 Pitch Servo Clutch Setting (lbs): 50 ± 3
 Pitch Trim Servo Clutch Setting (lbs): 20 ± 5
 Trim Sensor Point Gap (in.): $.010 \pm .002$
 Bridle Cable(s): Roll - 30B278 Pitch - 30B279
 Limitations Placard Part Number: See AFM Supplement

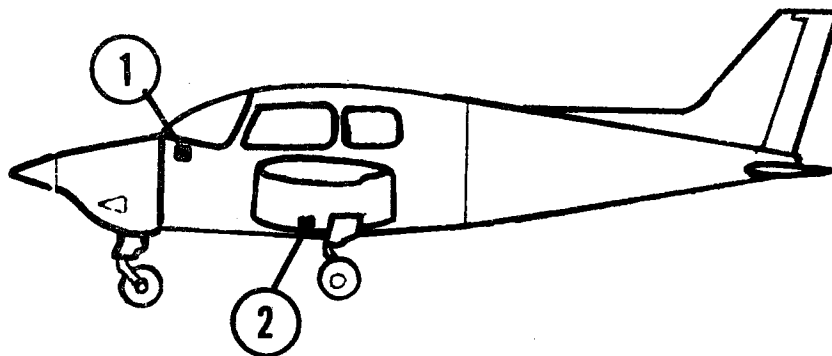
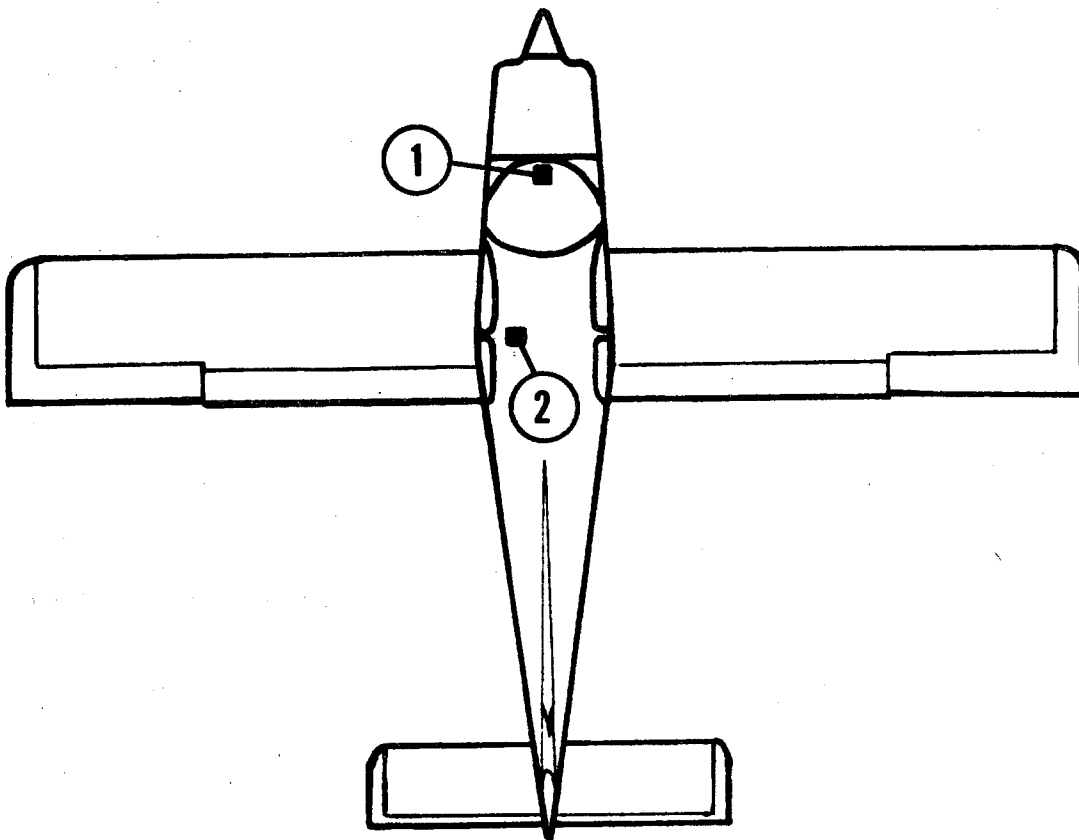

AK342

BEECH

MUSKETEER

19A, 1319, M19A, 23, A23A, B23, C23,
A23-19, A23-24, A24, A24R, A23

CENTURY II

AK342
STC SA1348SW

BEECH 19A, 1319, M19A, 23,
A23A, B23, C23, A23-19, A23-24
A24, A24R, A23

PART DESCRIPTION AND NOMENCLATURE	LOCATION
CONSOLE-AMPLIFIER 1C385	(1) Under the throttle quadrant
ROLL SIGNAL FILTER 1B440	(1) Under instrument panel near artificial horizon
ARTIFICIAL HORIZON 52D66	(1) Instrument panel
DIRECTIONAL GYRO 52D54	(1) Instrument panel
ROLL SERVO 1C363-1-341R	(2) Under floor and just aft of elevator trim pedestal. 8 1/2" forward of Station 126.75 left of C/L.
MAIN CABLE HARNESS 30C198	
RADIO COUPLER (OPT.) 1C388-()	(1) Instrument panel
<p>* Aircraft Models 23,A23 and A23A with aircraft serial numbers M-1 through M-962 and MA-1 through MA-27 must be modified in accordance with Beech Service News Letter, Volume XX No. 11 dated November 1967, before they are eligible for this autopilot installation.</p>	

SERVICING DATA

Roll Servo Clutch Setting (lbs): 30 ± 5

Pitch Servo Clutch Setting (lbs):

Pitch Trim Servo Clutch Setting (lbs):

Trim Sensor Point Gap (in.):

Bridle Cable(s): Roll - 30B383

Limitations Placard Part Number: 13A344-342

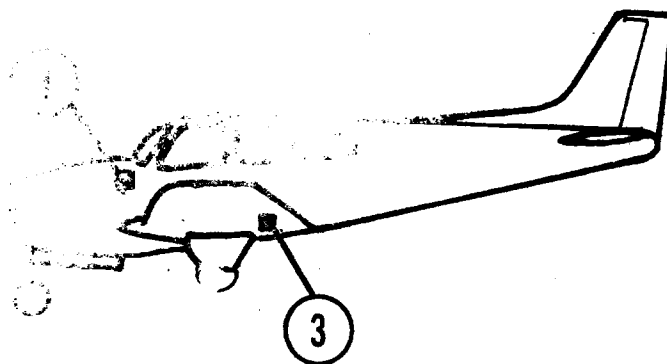
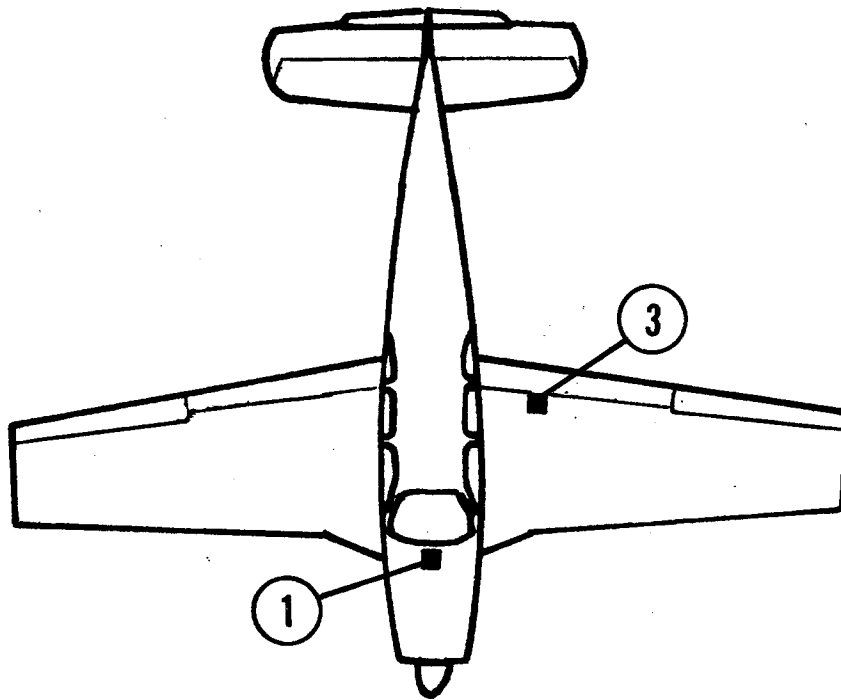

BEECH

BONANZA and DEBONAIR

35-A33, 35-B33, 35-C33
35C33A, E33, E33A, E33C, F83, F33A, F33C, G33

CENTURY II

AK311
STC SA1231SW

BEECH MODELS 35-A33, 35-B33, 35-C33
35-C33A, E33, E33A, E33C, F33, F33A,
F33C, G33,36 AND A36

PART DESCRIPTION AND NOMENCLATURE	LOCATION
CONSOLE-AMPLIFIER 1C385	(1) Instrument panel
ARTIFICIAL HORIZON 52D66	(1) Instrument panel
DIRECTIONAL GYRO 52D54	(1) Instrument panel
ROLL SERVO 1C363-1-275R	(3) Just aft of left main gear, just forward of rear spar, and between the first and second ribs.
MAIN CABLE HARNESS 30C198	
RADIO COUPLER (OPT.) 1C388	(1) Instrument panel

SERVICING DATA

Roll Servo Clutch Setting (lbs): $37 \begin{smallmatrix} +5 \\ -4 \end{smallmatrix}$
 Pitch Servo Clutch Setting (lbs):
 Pitch Trim Servo Clutch Setting (lbs):
 Trim Sensor Point Gap (in.):
 Bridle Cable(s): Roll - 30B258
 Limitations Placard Part Number: 13A344-311

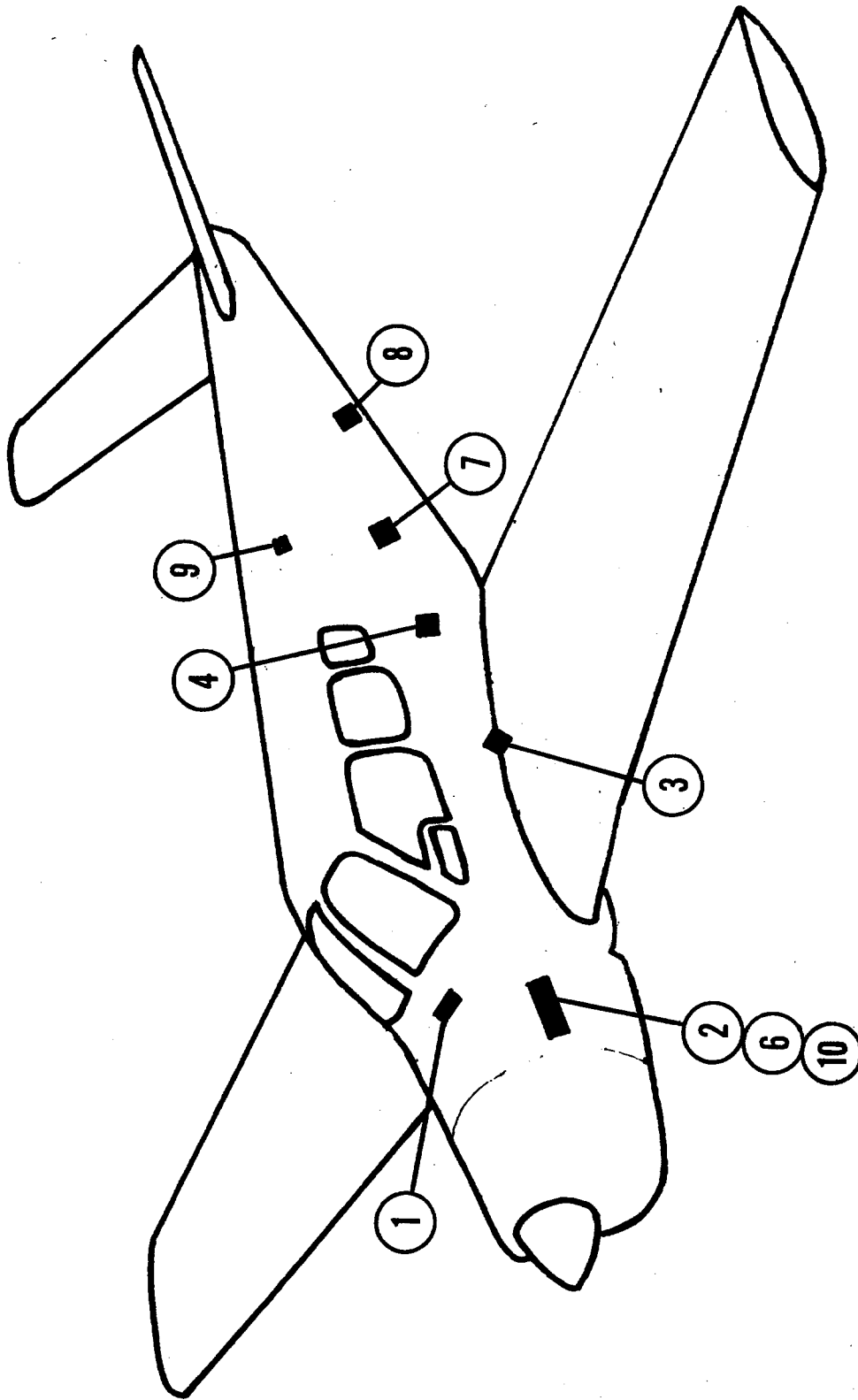

35-A33, 35-B33

BONANZA

BEECH

AK264

CENTURY III

AK264
STC SA896SW

BEECH 35-C33, 35A33

PART DESCRIPTION AND NOMENCLATURE	LOCATION
ROLL SIGNAL FILTER 1B440	(1) Under instrument panel near artificial horizon
CONSOLE 1C404	(1) Instrument panel
ARTIFICIAL HORIZON 52D67	(1) Instrument panel
DIRECTIONAL GYRO 52D54	(1) Instrument panel
ROLL SERVO 1C363-1-264R	(3) In front of rear spar, beneath center seats, left side
PITCH SERVO 1C508-1-264P	(4) In first bay aft of the partition between baggage compartment and aft fuselage at C/L bottom
ALTITUDE HOLD 1C407	(6) Aircraft radio rack, pilot's side, between instrument panel and firewall, left side
MAIN CABLE HARNESS 30D207-1	
* GYRO-AMPLIFIER 1C359	(9) Mounted to aft-side of partition between baggage compartment and aft fuselage, top lft.
RADIO COUPLER 1C388-()	(1) Instrument panel
TRIM SERVO 1C373-1-264	(7) In aft fuselage in second bay aft of baggage compartment near Station 179.00 left of A/C C/L
TRIM SENSOR 1C326-264	(8) At second bulkhead aft of the partition between baggage compartment and aft fuselage Station 207.00 center
TRIM AMP 79C54-1	
TRIM SWITCH 30B192	Left side pilot's wheel
AMPLIFIER 1D395	(2) aircraft radio rack, pilot's side, between instrument panel and firewall
SWITCH BOX 1B405	(10) On radio rack, between instrument panel and firewall, pilot's side
*1C359 Gyro-Amplifier optional with 1B405 Switch Box and 30B184 Cable Assembly	

SERVICING DATA

Roll Servo Clutch Setting (lbs): $37 \pm \frac{3}{2}$
 Pitch Servo Clutch Setting (lbs): 18 ± 2
 Pitch Trim Servo Clutch Setting (lbs): 35 ± 5
 Trim Sensor Point Gap (in.):
 Bridle Cable(s): Roll - 30B304 Pitch - 30B276
 Limitations Placard Part Number: 13A329-264

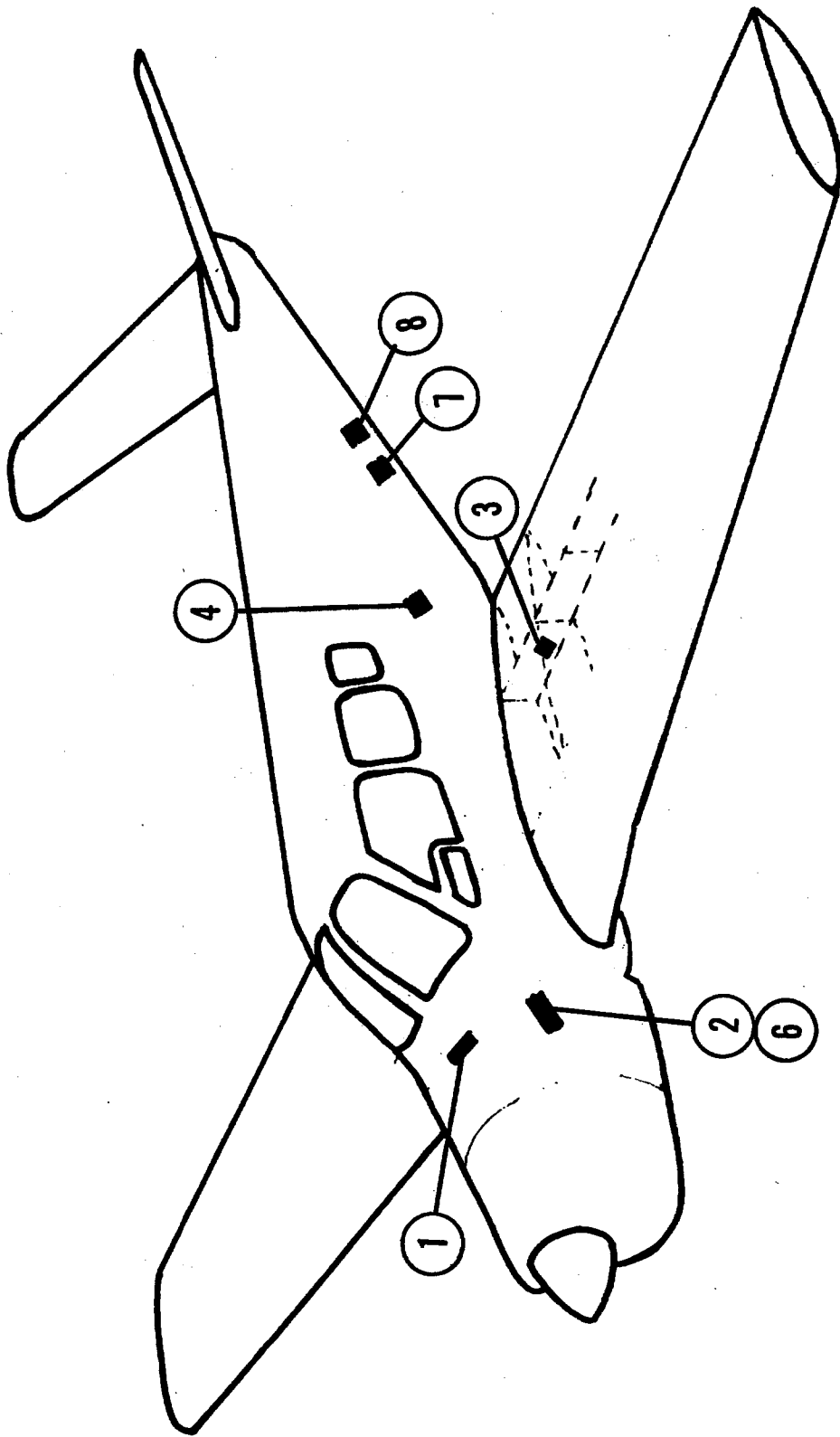

AK347 BEECH BONANZA 35-C33, E33, F33

CENTURY III

AK347
STC SA1365SW

BEECH 35-C33, E33 AND F33

PART DESCRIPTION AND NOMENCLATURE	LOCATION
CONSOLE 1C404	(1) Instrument panel
ARTIFICIAL HORIZON 52D67	(1) Instrument panel
DIRECTIONAL GYRO 52D54	(1) Instrument panel
ROLL SERVO 1C363-1-306R	(3) aft of left main landing gear well, forward of rear spar
PITCH SERVO 1C508-1-264P	(4) First bay aft of partition between baggage compartment and aft fuselage on C/L
ALTITUDE HOLD 1C407	(6) On aircraft radio rack, pilot's side between instrument panel and firewall
MAIN CABLE HARNESS 30D207-3	
RELAY BOX 1A526	(1) Under instrument panel
RADIO COUPLER 1C388-()	(1) Instrument panel
GLIDE SLOPE COUPLER 1C493	(1) Behind instrument panel within 3 feet of artificial horizon
G.S. COUPLER HARNESS 30C291	
TRIM SERVO 1C373-5-316	(7) Second bay aft of baggage compartment in aft fuselage left of C/L
TRIM SENSOR 1C654-316	(8) At second bulkhead aft of partition between baggage compartment and aft fuselage on C/L
TRIM SWITCH 30B416	Pilot's control wheel
TRIM AMP AMPLIFIER 1C515-1	Second bay aft of baggage compartment in aft fuselage left of C/L (2) On aircraft radio rack, pilot's side, between instrument panel and firewall

SERVICING DATA

Roll Servo Clutch Setting (lbs): 35 ± 10

Pitch Servo Clutch Setting (lbs): 18 ± 2

Trim Servo Clutch Setting (lbs): 26 ± 7

Trim Sensor Point Gap (in.): $.007 \pm .002$

Bridle Cable(s): Roll - 30B258 Pitch - 30B276

Limitations Placard Part Number: See AFM Supplement

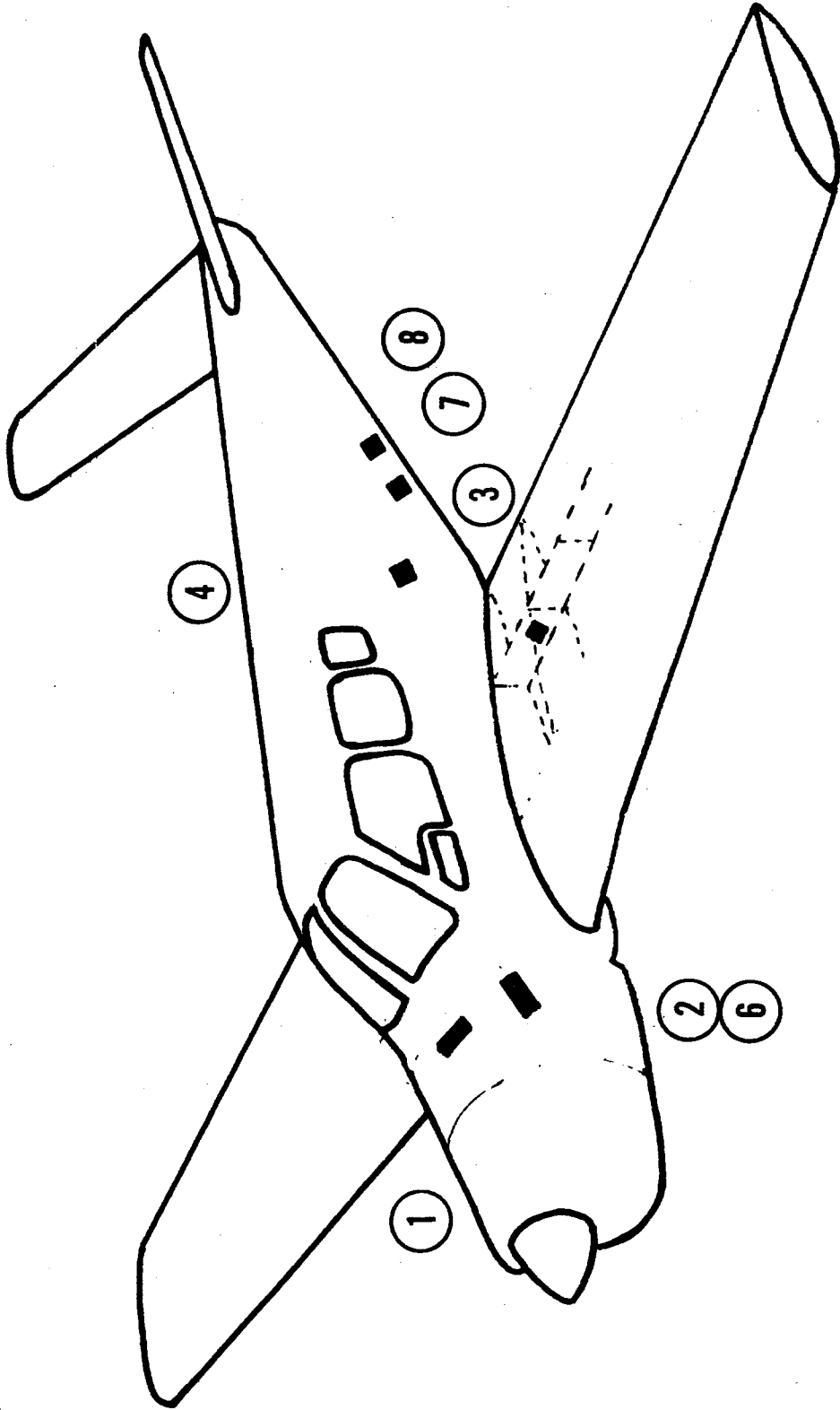

AK316 BEECH BONANZA 35C33A, E33A, E33C, F33A(CE-315 and below), F33C, G33

CENTURY III

AK316
STC SA1366SW

BEECH 35-C33A, E33A,
E33C, F33A AND G33

PART DESCRIPTION AND NOMENCLATURE	LOCATION
<p>CONSOLE 1C404</p> <p>ARTIFICIAL HORIZON 52D67</p> <p>DIRECTIONAL GYRO 52D54</p> <p>ROLL SERVO 1C363-1-306R</p> <p>PITCH SERVO 1C508-1-316P</p> <p>ALTITUDE HOLD 1C407</p> <p>MAIN CABLE HARNESS 30D207-3</p> <p>RELAY BOX 1A526</p> <p>RADIO COUPLER 1C388-M and MC</p> <p>GLIDE SLOPE COUPLER 1C493</p> <p>G.S. COUPLER HARNESS 30C291</p> <p>TRIM SERVO 1C373-5-316</p> <p>TRIM SENSOR 1C654-316</p> <p>TRIM SWITCH 30B416</p> <p>TRIM AMP 1C671</p> <p>AMPLIFIER 1C515-1</p>	<p>(1) Instrument panel</p> <p>(1) Instrument panel</p> <p>(1) Instrument panel</p> <p>(3) Aft of left main gear well and just forward of rear spar</p> <p>(4) In first bay aft of partition between baggage compartment and aft fuselage on C/L</p> <p>(6) On aircraft radio rack, pilot's side between instrument panel and firewall</p> <p>(5) Under instrument panel</p> <p>(1) Instrument panel</p> <p>(1) Behind instrument panel within 3 feet of artificial horizon</p> <p>(7) In aft fuselage in second bay aft of baggage compartment Station 179.00, left of C/L</p> <p>(8) In aft fuselage in second bay aft of baggage compartment, Station 207.00 on C/L</p> <p>Pilot's control wheel</p> <p>In aft fuselage in second bay aft of baggage compartment, Station 179.00, left of C/L</p> <p>(2) on aircraft radio rack, pilot's side between instrument panel and firewall.</p>

SERVICING DATA

Roll Servo Clutch Setting (lbs): 35 ± 10
 Pitch Servo Clutch Setting (lbs): 19 ± 4
 Trim Servo Clutch Setting (lbs): 26 ± 7
 Trim Sensor Point Gap (in.): $.007 \pm .002$
 Bridle Cable(s): Roll - 30B258 Pitch - 30B276
 Limitations Placard Part Number: See AFM Supplement

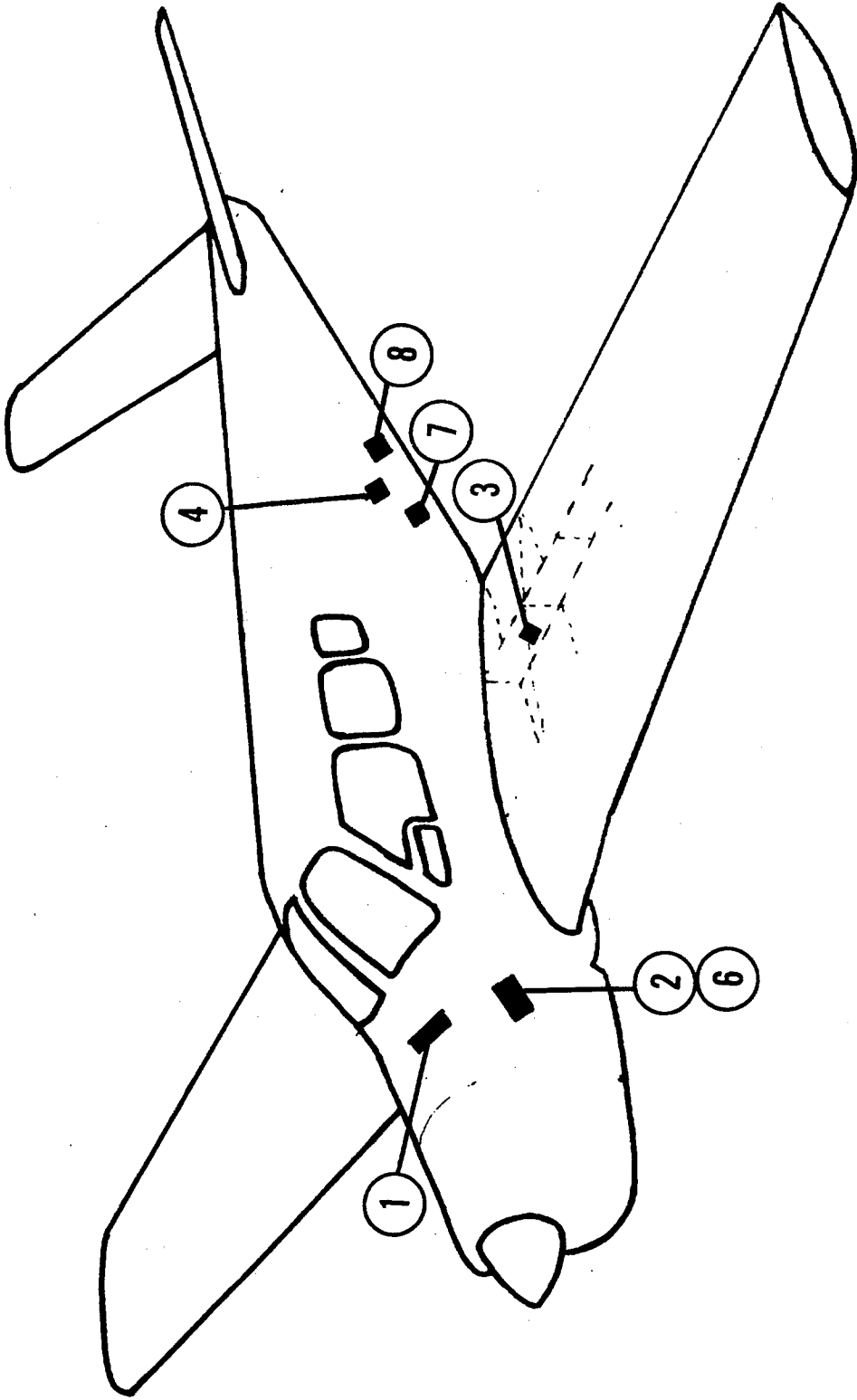

AK315 BEECH BONANZA F33A, S/N CE316 and up.

CENTURY III

AK315
STC SA1232SW

BEECH F33A S/N CE316 and UP

PART DESCRIPTION AND NOMENCLATURE	LOCATION
CONSOLE 1C404	(1) Instrument panel
ARTIFICIAL HORIZON 52D67	(1) Instrument panel
DIRECTIONAL GYRO 52D54	(1) Instrument panel
ROLL SERVO 1C363-1-306R	(3) Aft of left main gear well and just forward of rear spar
PITCH SERVO 1C508-1-315P	(4) Just aft of Station 216 and near centerline of aircraft
ALTITUDE HOLD 1C407	(6) On aircraft radio rack, pilot's side between instrument panel and firewall
MAIN CABLE HARNESS 30C207-3	
RELAY BOX 1A526	(5) Under instrument panel
RADIO COUPLER 1C388	(1) Instrument panel
GLIDE SLOPE COUPLER	REFER TO AK262
TRIM SERVO 1C373-5-315	(7) Just forward of second bulkhead (Station 207) aft of rear baggage compartment door post
TRIM SENSOR 1C647-315	(8) Aft fuselage section at Station 233.5 near centerline of aircraft, left side of C/L
TRIM SWITCH 30A364	Pilot's control wheel
AMPLIFIER 1C515-1	(2) Aircraft radio rack, pilot's side, between instrument panel and firewall

SERVICING DATA

Roll Servo Clutch Setting (lbs): 35 ± 10

Pitch Servo Clutch Setting (lbs): 19 ± 4

Trim Servo Clutch Setting (lbs): 26 ± 7

Trim Sensor Point Gap (in.): $.007 \pm .002$

Bridle Cable(s): Roll - 30B258 Pitch - 30B407

Limitations Placard Part Number: See AFM Supplement

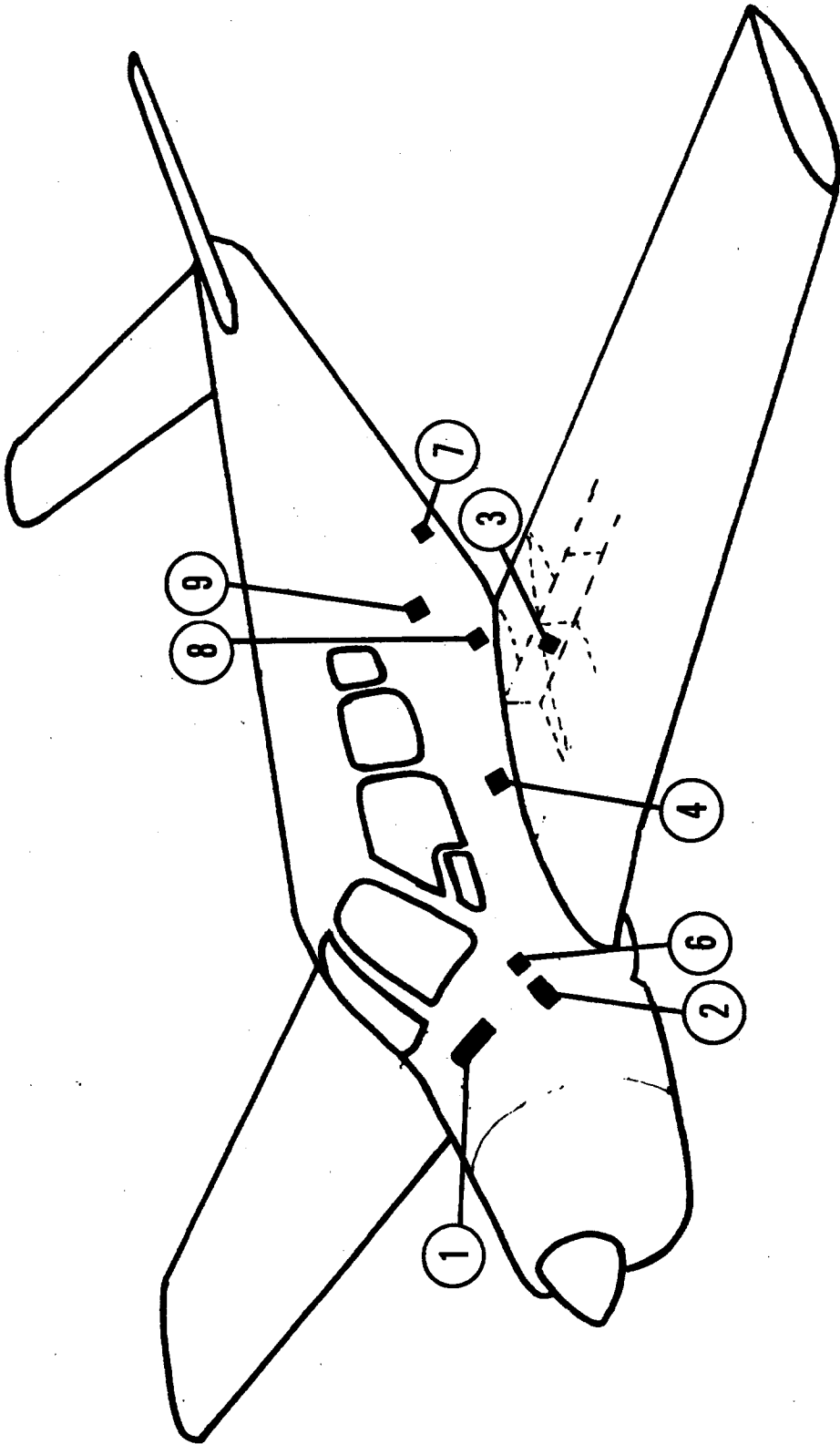

AK202 BEECH BONANZA J35, K35, M35, N35, P35, S35

AK202 BEECH BONANZA

AK202

CENTURY III

AK202
STC SA638SW

BEECH J35, K35, M35, N35,
P35, S35

PART DESCRIPTION AND NOMENCLATURE	LOCATION
CONSOLE 1C404	(1) Instrument panel
ARTIFICIAL HORIZON 52D67	(1) Instrument panel
DIRECTIONAL GYRO 52D54	(1) Instrument panel
ROLL SERVO 1D363-202R	(3) Just outboard of fuselage in left wing forward of rear spar (landing gear wheel door)
PITCH SERVO 1D363-202P	(4) Under floor, in front of rear wing spar, left of A/C centerline
ALTITUDE HOLD 1C407	(6) aircraft radio rack, pilot's side between instrument panel and firewall
MAIN CABLE HARNESS 30D207-1	
* GYRO-AMPLIFIER 1C359	(9) On the partition between baggage compartment and aft fuselage, co-pilot's side
RADIO COUPLER 1C388	(1) Instrument panel
TRIM SERVO 1D373-167	(7) Behind baggage compartment left side where trim cables go up from bottom of fuselage
TRIM SENSOR 1C318-194	(8) Under floor, center, just aft of rear spar
TRIM SWITCH 30A204	Pilot's control wheel
AMPLIFIER 1D395	(2) Aircraft radio rack, pilot's side between instrument panel and firewall
<p>* 1C359 Gyro-Amplifier optional with 1B405 Switch Box and 30B184 Cable Assembly</p>	

SERVICING DATA

Roll Servo Clutch Setting (lbs): 32 + 3
 Pitch Servo Clutch Setting (lbs): 16 ± 3
 Pitch Trim Servo Clutch Setting (lbs): 25 ± 5
 Trim Sensor Point Gap (in.): .014 ± .002
 Bridle Cable(s): Roll - 30B242 Pitch - 30B241
 Limitations Placard Part Number: 13A392-202

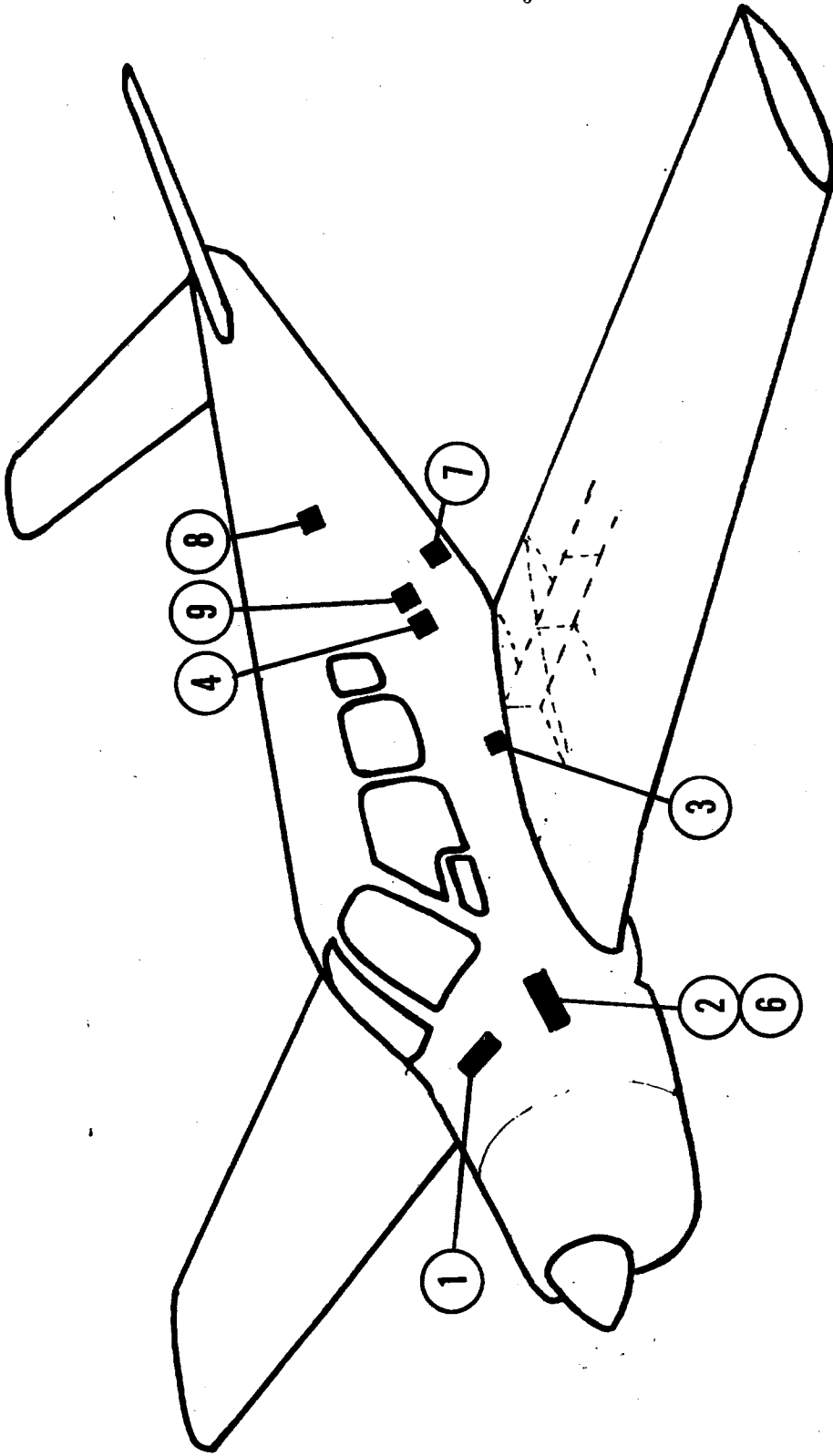

AK260

BEECH BONANZA

V35ATC, V35BTC

CENTURY III

AK260
STC SA882SW

BEECH V35ATC & V35BTC WHEN
MODIFIED PER STC SA1035WE

PART DESCRIPTION AND NOMENCLATURE	LOCATION
CONSOLE 1C404	(1) Instrument panel
ARTIFICIAL HORIZON 52D67	(1) Instrument panel
DIRECTIONAL GYRO 52D54	(1) Instrument panel
ROLL SERVO 1C363-1-260R	(3) In front of rear spar, under center seats, left side
PITCH SERVO 1C508-1-260P	(4) In first bay aft of partition between baggage compartment and aft fuselage right C/L on bottom
ALTITUDE HOLD 1C407	(6) On aircraft radio rack, pilot's side between instrument panel and firewall
MAIN CABLE HARNESS 30D207-1	
*GYRO-AMPLIFIER 1C359	(9) Mounted to aft side, right bottom of partition between baggage compartment and aft fuselage.
RADIO COUPLER 1C388	(1) Instrument panel
TRIM SERVO 1D373-260	(7) In aft of fuselage where trim cables go up from bottom of aircraft, left side
TRIM SENSOR 1C318-260	(8) Just aft of second bulkhead, aft of partition between baggage compartment and aft fuselage
AMPLIFIER 1D395	(2) On aircraft radio rack, pilot's side, between instrument panel and firewall
SWITCH BOX 1B405	(10) On radio rack between instrument panel and firewall, left side
*1C359 Gyro-Amplifier (Stabilizer) Optional with 1B405 Switch Box and 30B184 Cable Assembly.	

SERVICING DATA

Roll Servo Clutch Setting (lbs): 32 ± 3
 Pitch Servo Clutch Setting (lbs): 24 ± 4
 Pitch Trim Servo Clutch Setting (lbs): 20 ± 5
 Trim Sensor Point Gap (in.): $.010 \pm .002$
 Bridle Cable(s): Roll - 30B304 Pitch - 30B302
 Limitations Placard Part Number: 13A329-260

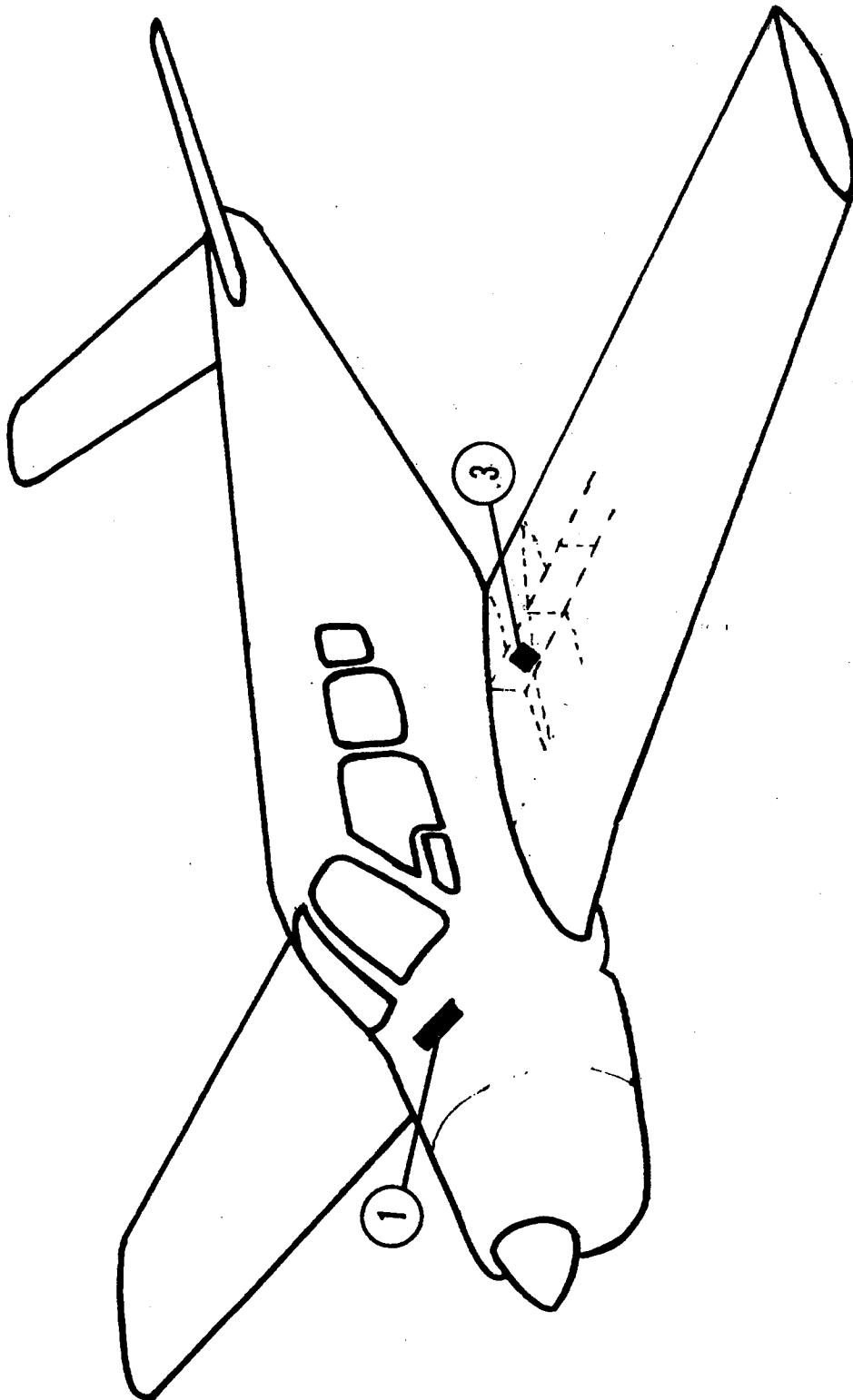

AK245 BEECH BONANZA 35

CENTURY II

AK245
STC SA800SW

BEECH MODEL 35

PART DESCRIPTION AND NOMENCLATURE	LOCATION
CONSOLE-AMPLIFIER 1C385	(1) Instrument panel
ARTIFICIAL HORIZON 52D66	(1) Instrument panel
DIRECTIONAL GYRO 52D54	(1) Instrument panel
ROLL SERVO 1D363-226R	(3) Forward of rear spar just outboard of fuselage, left side (left gear door)
MAIN CABLE HARNESS 30C198	
RADIO COUPLER (OPT.) 1C388-()	(1) Instrument panel

SERVICING DATA

Roll Servo Clutch Setting (lbs): 45 ± 5
 Pitch Servo Clutch Setting (lbs):
 Pitch Trim Servo Clutch Setting (lbs):
 Trim Sensor Point Gap (in.):
 Bridle Cable(s): Roll - 30B242,
 Limitations Placard Part Number: 13A344-245

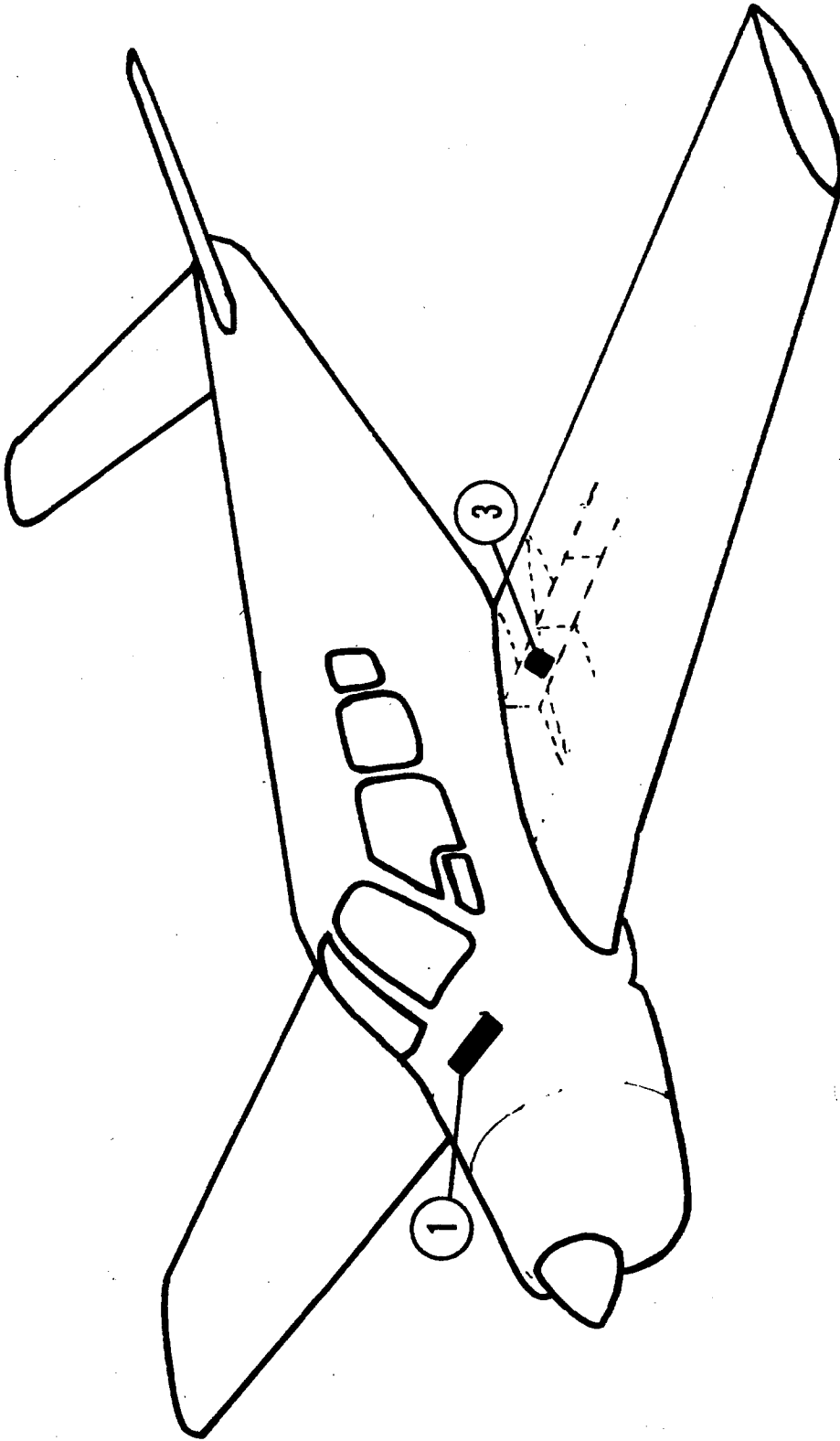

AK248 BEECH BONANZA
A35, B35, C35, D35, E35, F35, G35, H35,
J35, K35, M35, N35, P35, S35 and V35

CENTURY II

AK248
STC SA824SW

BEECH MODEL 35 SERIES:
A35, B35, C35, D35, E35, F35, G35, H35
J35, K35, M35, N35, P35, S35

PART DESCRIPTION AND NOMENCLATURE	LOCATION
CONSOLE-AMPLIFIER 1C385	(1) Instrument panel
ARTIFICIAL HORIZON 52D67	(1) Instrument panel
DIRECTIONAL GYRO 52D54	(1) Instrument panel
ROLL SERVO 1D363-202R	(3) Just outboard of fuselage in left wing forward of rear spar (landing gear wheel door)
MAIN CABLE HARNESS 30C198	
RADIO COUPLER (OPT.) 1C388	(1) Instrument panel

SERVICING DATA

Roll Servo Clutch Setting (lbs): 32 ± 3
 Pitch Servo Clutch Setting (lbs):
 Pitch Trim Servo Clutch Setting (lbs):
 Trim Sensor Point Gap (in.):
 Bridle Cable(s): Roll - 30B242
 Limitations Placard Part Number: 13A344-248

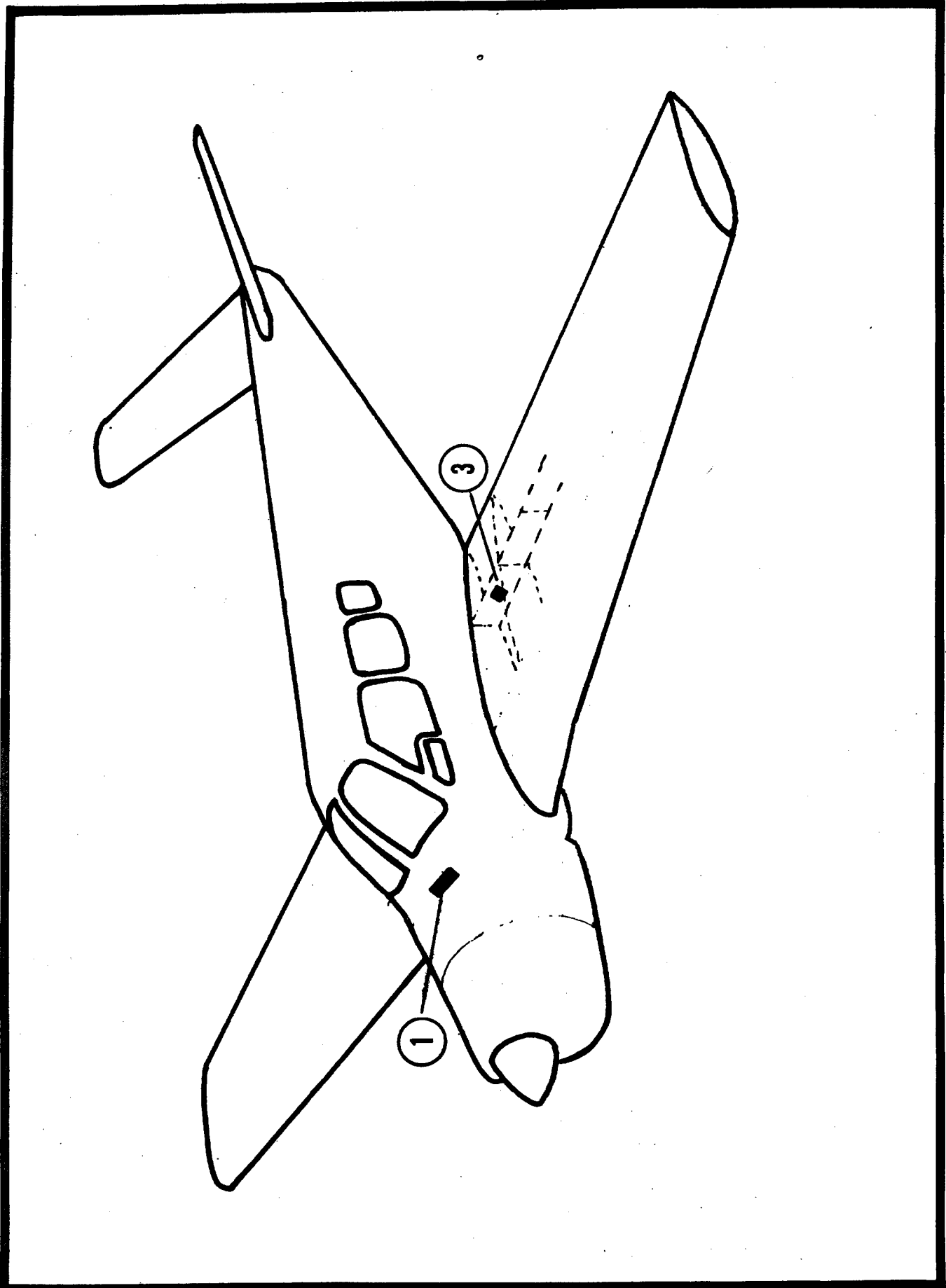

CENTURY II

AK263
STC SA925SW

BEECH MODELS V35, V35A,
V35B

PART DESCRIPTION AND NOMENCLATURE	LOCATION
CONSOLE-AMPLIFIER 1C385	(1) Instrument panel
ARTIFICIAL HORIZON 52D66	(1) Instrument panel
DIRECTIONAL GYRO 52D54	(1) Instrument panel
ROLL SERVO 1C363-1-260R	(3) In front of rear spar, under center seats, left side
MAIN CABLE HARNESS 30C198	
RADIO COUPLER (OPT.) 1C388-M	(1) Instrument panel

SERVICING DATA

Roll Servo Clutch Setting (lbs): 32 ± 3
 Pitch Servo Clutch Setting (lbs):
 Pitch Trim Servo Clutch Setting (lbs):
 Trim Sensor Point Gap (in.):
 Bridle Cable(s): Roll - 30B304
 Limitations Placard Part Number: 13A344-263

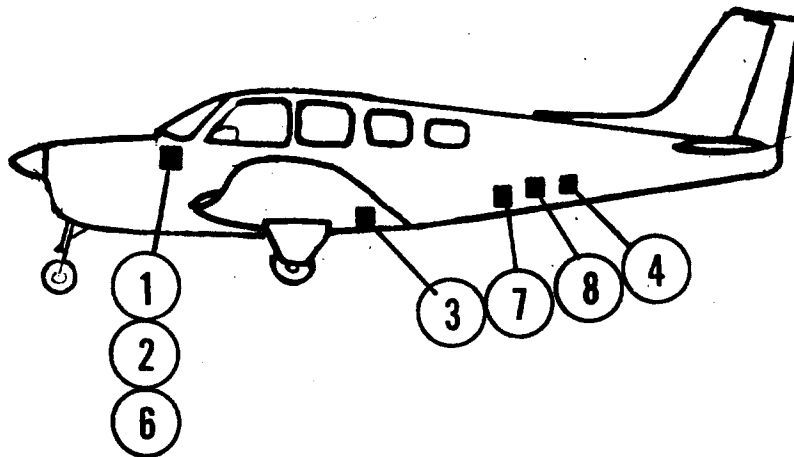
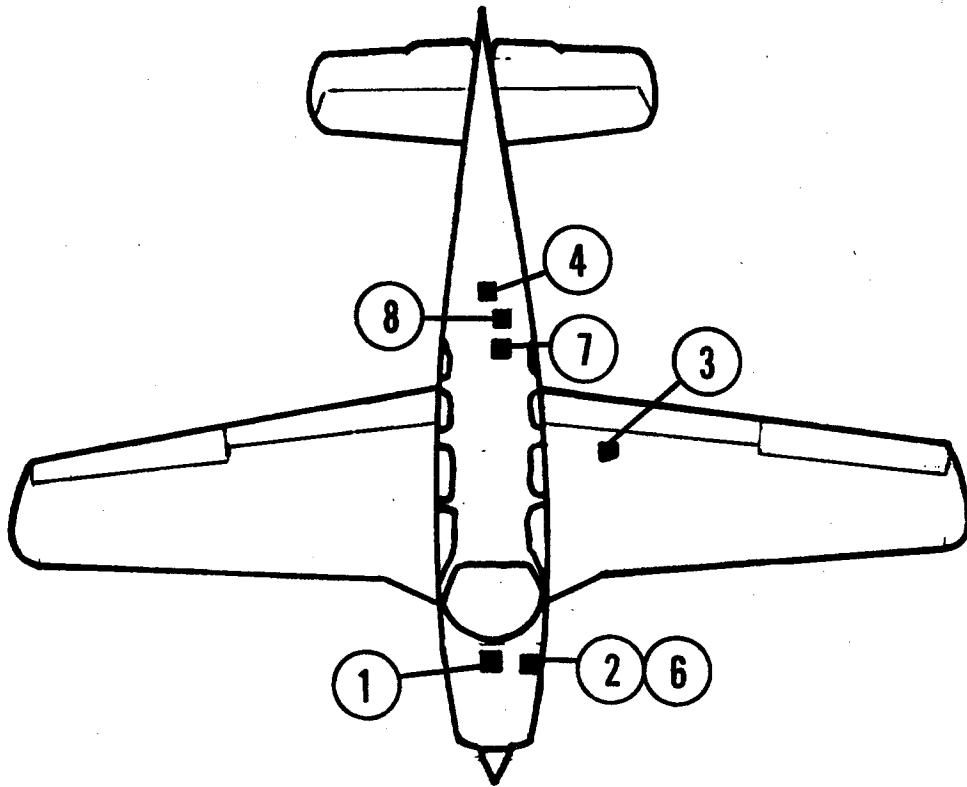

AK346

BEECH

BONANZA

36, A36

CENTURY III

AK346
STC SA1360SW

BEECH 36 AND A36

PART DESCRIPTION AND NOMENCLATURE	LOCATION
CONSOLE 1C404	(1) Instrument panel
ARTIFICIAL HORIZON 52D67	(1) Instrument panel
DIRECTIONAL GYRO 52D54	(1) Instrument panel
ROLL SERVO 1C363-1-306R	(3) Aft of left main gear well and just forward of rear spar
PITCH SERVO 1C508-1-346P	(4) Just aft of Station 216 near centerline of aircraft
ALTITUDE HOLD 1C407	(6) On aircraft radio rack, pilot's side between instrument panel and firewall
MAIN CABLE HARNESS 30D207-3	
RELAY BOX 1A526	(5) Under Instrument panel
RADIO COUPLER 1C388-()	(1) Instrument panel
GLIDE SLOPE COUPLER 1C493	Behind instrument panel within 3 feet of artificial horizon
G.S. COUPLER HARNESS 30C291	
TRIM SERVO 1C373-5-315	(7) Just forward of second bulkhead left of C/L, aft of rear baggage compartment door post (remove 5th and 6th seats)
TRIM SENSOR 1C647-315	(8) Aft fuselage at station 233.5 near centerline of aircraft
TRIM SWITCH 30B416	Pilot's control wheel
TRIM AMP 1C671	Just forward of second bulkhead left of C/L, aft of rear baggage compartment door post (remove 5th and 6th seats)
AMPLIFIER 1C515-1	(2) On aircraft radio rack, pilot's side, between instrument panel and firewall

SERVICING DATA

Roll Servo Clutch Setting (lbs): 35 ± 10

Pitch Servo Clutch Setting (lbs): $30 \begin{matrix} +3 \\ -2 \end{matrix}$

Roll Trim Servo Clutch Setting (lbs): 26 ± 7

Trim Sensor Point Gap (in.): $.007 \pm .002$

Bridle Cable(s): Roll - 30B258 Pitch - 30B407

Limitations Placard Part Number: See AFM Supplement

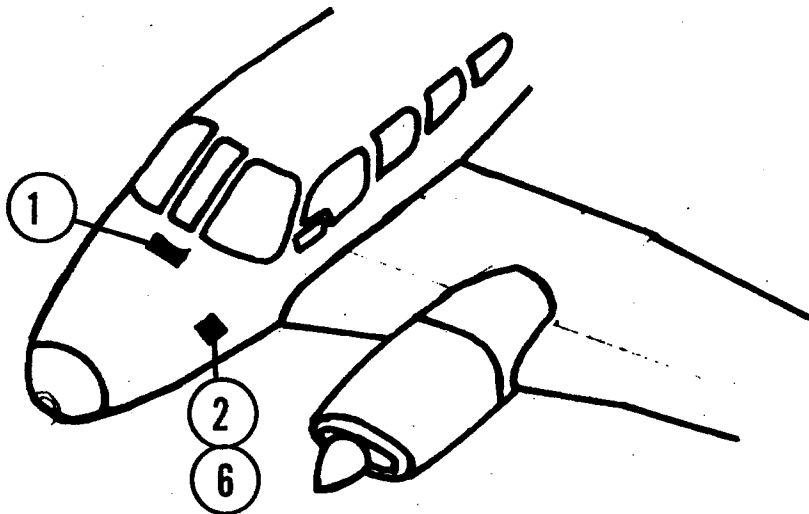
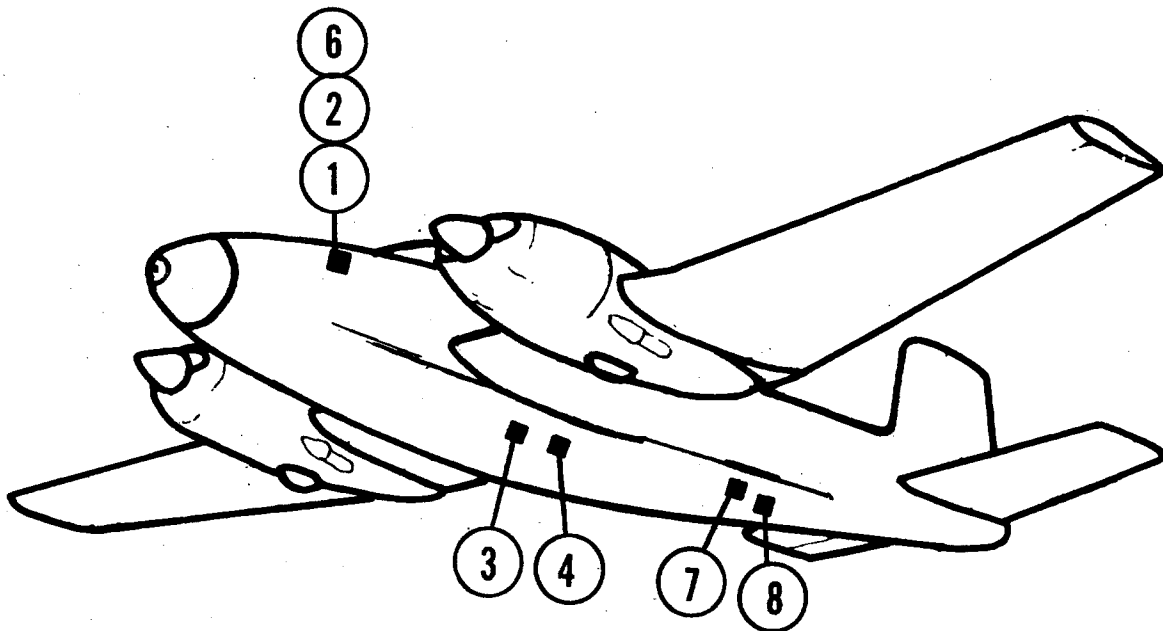

AK337

BEECH TWIN BONANZA

D50A, D50B, D50, D50E

CENTURY II

AK337
STC SA1334SW

BEECH D50A, D50B,
D50C, D50E

PART DESCRIPTION AND NOMENCLATURE	LOCATION
CONSOLE-AMPLIFIER 1C385-24	(1) Instrument panel
ARTIFICIAL HORIZON 52D66	(1) Instrument panel
* DIRECTIONAL GYRO 52D54	(1) Instrument panel
ROLL SERVO 1C470-255R	(3) Under floorboard in center cabin section, aft of main spar
MAIN CABLE HARNESS 30C198	
RADIO COUPLER (OPT.) 1C388-M	(1) Instrument panel
* 1C465-1-225R (60 ± 4) for D50C	- Same location as 1C470-255R

SERVICING DATA

Roll Servo Clutch Setting (lbs): 60 ± 4
 Pitch Servo Clutch Setting (lbs):
 Pitch Trim Servo Clutch Setting (lbs):
 Trim Sensor Point Gap (in.):
 Bridle Cable(s): Roll -30B425 , 30B200
 Limitations Placard Part Number: 13A344-337

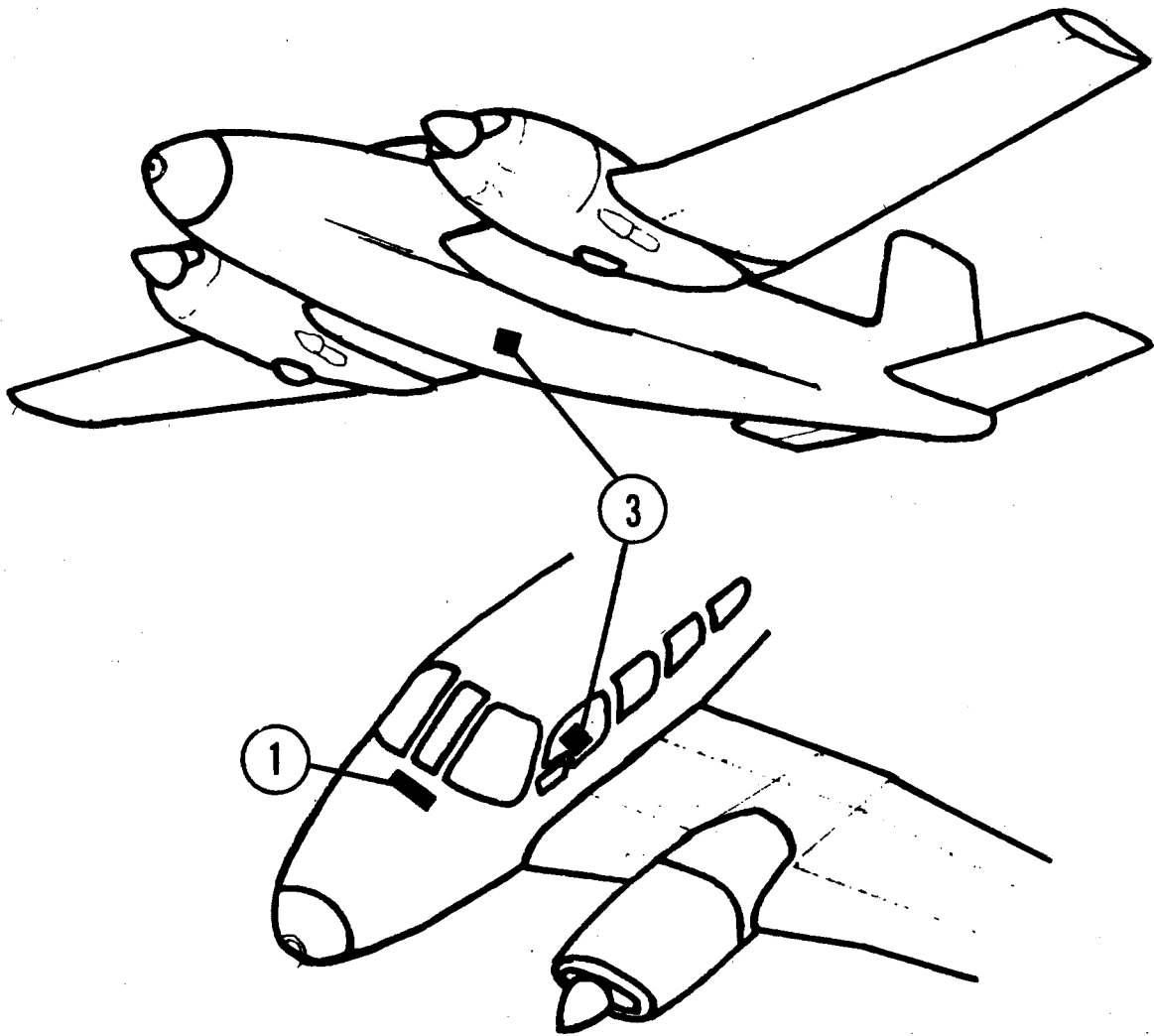

AK255

BEECH TWIN BONANZA

D50E

CENTURY III

AK255
STC SA837SW

BEECH D50E

PART DESCRIPTION AND NOMENCLATURE	LOCATION
CONSOLE 1C404	(1) Instrument panel
ARTIFICIAL HORIZON 52D67	(1) Instrument panel
DIRECTIONAL GYRO 52D54	(1) Instrument panel
ROLL SERVO 1C470-255R	(3) Just aft of main wing spar under floorboard, left side
PITCH SERVO 1C502-255P	(4) Under floorboard, in second bay aft of rear main spar, left side
ALTITUDE HOLD 1C407	(6) On bulkhead ring, left side, between instrument panel and forward bulkhead
MAIN CABLE HARNESS 30D207-3	
RADIO COUPLER 1C388-M	(1) Instrument panel
TRIM SERVO 1D368-255	(7) Just aft of the aft baggage compartment bulkhead, on A/C left side, bottom
TRIM SENSOR 1C326-255	(8) Just aft of the second bulkhead, aft, of the aft baggage compartment, bottom on C/L
AMPLIFIER 1D395	(2) On bulkhead ring between instrument panel and forward bulkhead, left side

SERVICING DATA

Roll Servo Clutch Setting (lbs): 60 ± 4
 Pitch Servo Clutch Setting (lbs): 18 ± 2
 Pitch Trim Servo Clutch Setting (lbs): 21 ± 2
 Trim Sensor Point Gap (in.): $.014 \pm .002$
 Bridle Cable(s): Roll - 30B200 Pitch - 30B267
 Limitations Placard Part Number: See AFM Supplement

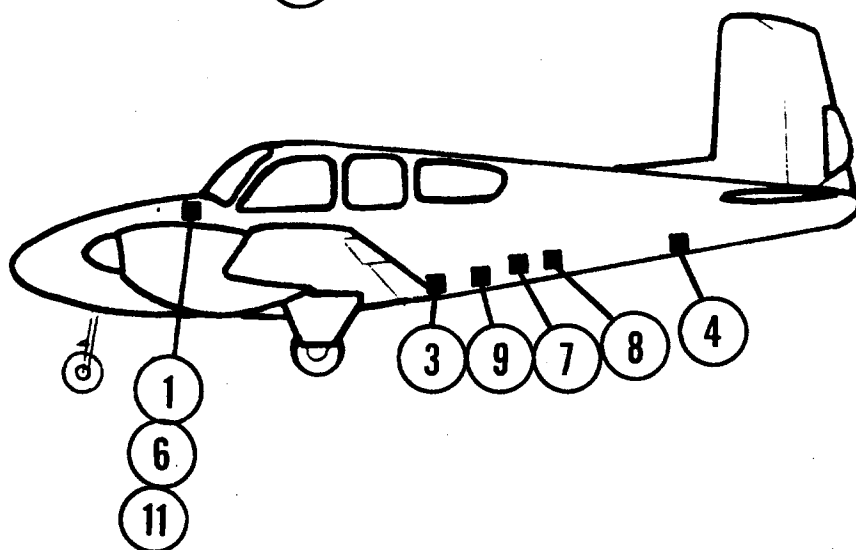
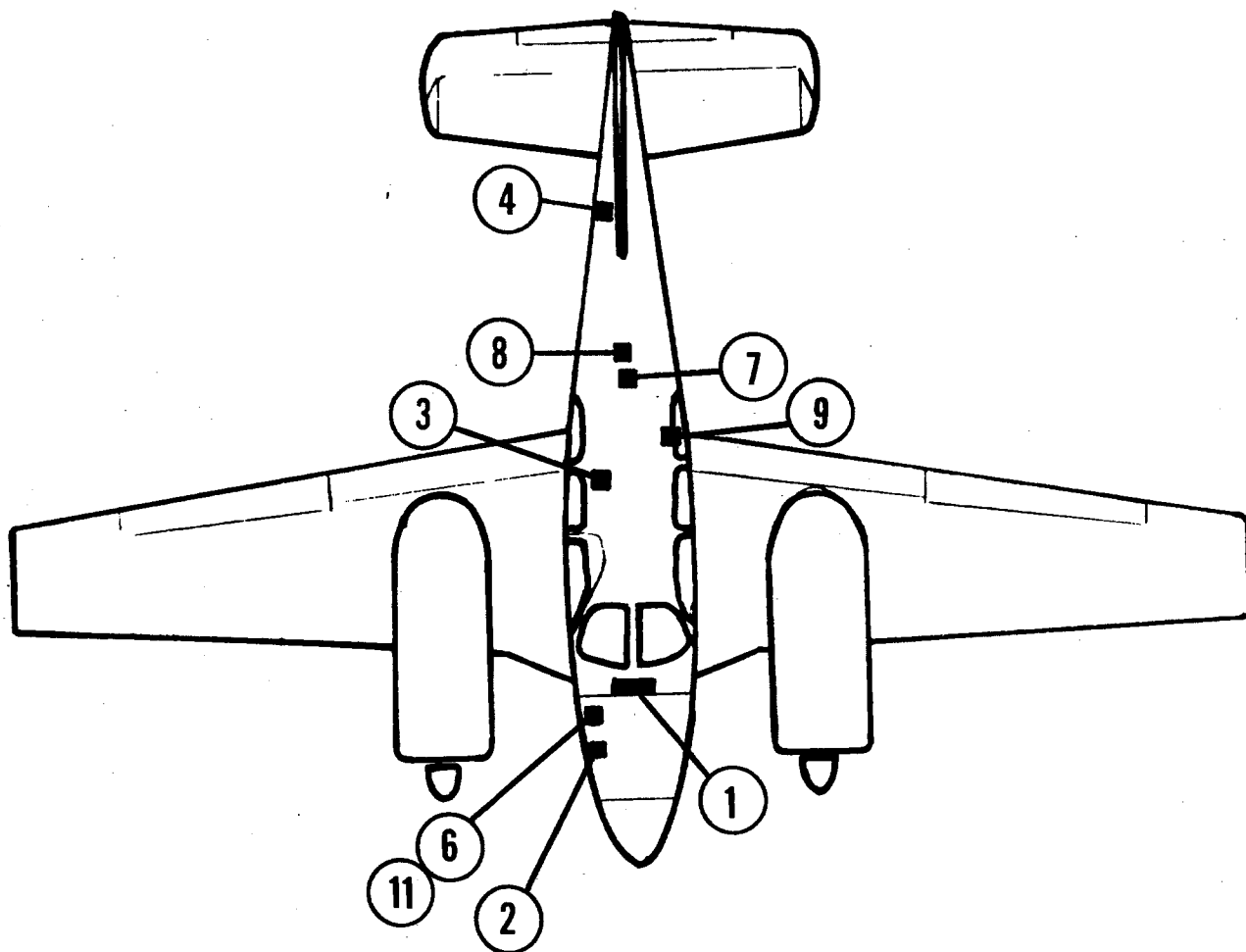

AK292

BEECH BARON

95-55, 95-A55, 95-B55, 95-C55, 95-B55B,
D55, D55A, E55, E55A

CENTURY III

AK292
STC SA1173SW

BEECH BARON 95-55, 95-A55, 95-B55,
95B-55B, 95C-55, D55, D55A, E55 AND
E55A

PART DESCRIPTION AND NOMENCLATURE	LOCATION
PITCH SIGNAL FILTER 1B440-1	(1) Under instrument panel near artificial horizon (For 1D395 only)
CONSOLE 1C404	(1) Upper portion radio panel
ARTIFICIAL HORIZON 52D67	(1) Instrument panel
DIRECTIONAL GYRO. 52D54	(1) Instrument panel
ROLL SERVO 1C465-1-303R	(3) Under center seats, forward edge of rear spar, right side of A/C
PITCH SERVO 1C470-1-292P	(4) Aft of rear baggage compartment between first and second bulkheads
ALTITUDE HOLD 1C407	(6) Aircraft structure between low center of instrument panel and forward cabin bulkhead, on co-pilot's side
MAIN CABLE HARNESS 30D207-4	
GYRO-AMPLIFIER 1C359	(9) Beneath aft baggage floor, pilot's side
RADIO COUPLER 1C388-M	(1) Instrument panel
TRIM SERVO 1C469-1-303	(7) In aft fuselage behind baggage compartment, left of C/L of A/C
TRIM SENSOR 1C647-303	(8) Second bulkhead aft of the rear baggage compartment, C/L of A/C
AMPLIFIER (24V) 1D395 or 1C515-1	(2) Aft corner of nose baggage compartment, co-pilot's side or forward side of forward cabin bulkhead or radio rack in nose baggage compartment
SWITCH BOX 1B405-24	(10) Any available space within 8 inches of the roll servo
INVERTER 48C17	(11) Under instrument panel, co-pilot's side, and forward cabin bulkhead or on radio rack forward nose baggage compartment or forward side of forward cabin bulkhead

SERVICING DATA

Roll Servo Clutch Setting (lbs): $45 \begin{smallmatrix} +5 \\ -6 \end{smallmatrix}$
 Pitch Servo Clutch Setting (lbs): 13 ± 2
 Pitch Trim Servo Clutch Setting (lbs): $25 \begin{smallmatrix} +5 \\ -2 \end{smallmatrix}$
 Trim Sensor Point Gap (in.): $.007 \pm .002$
 Bridle Cable(s): Roll - 30B221 Pitch - 30B263
 Limitations Placard Part Number: See AFM Supplement

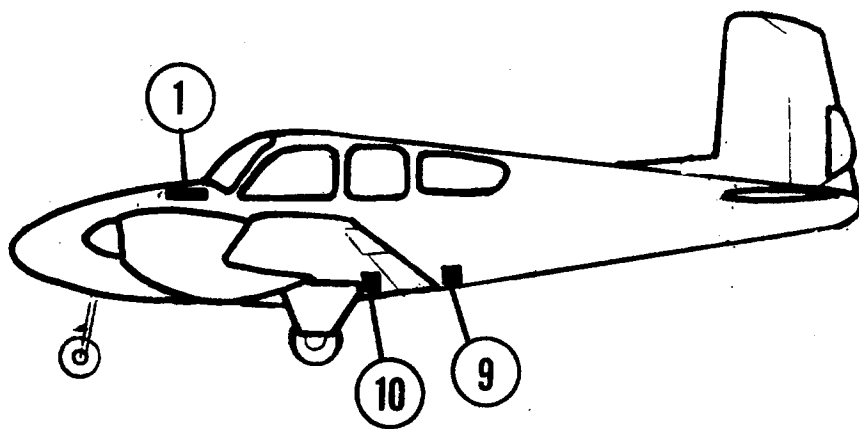
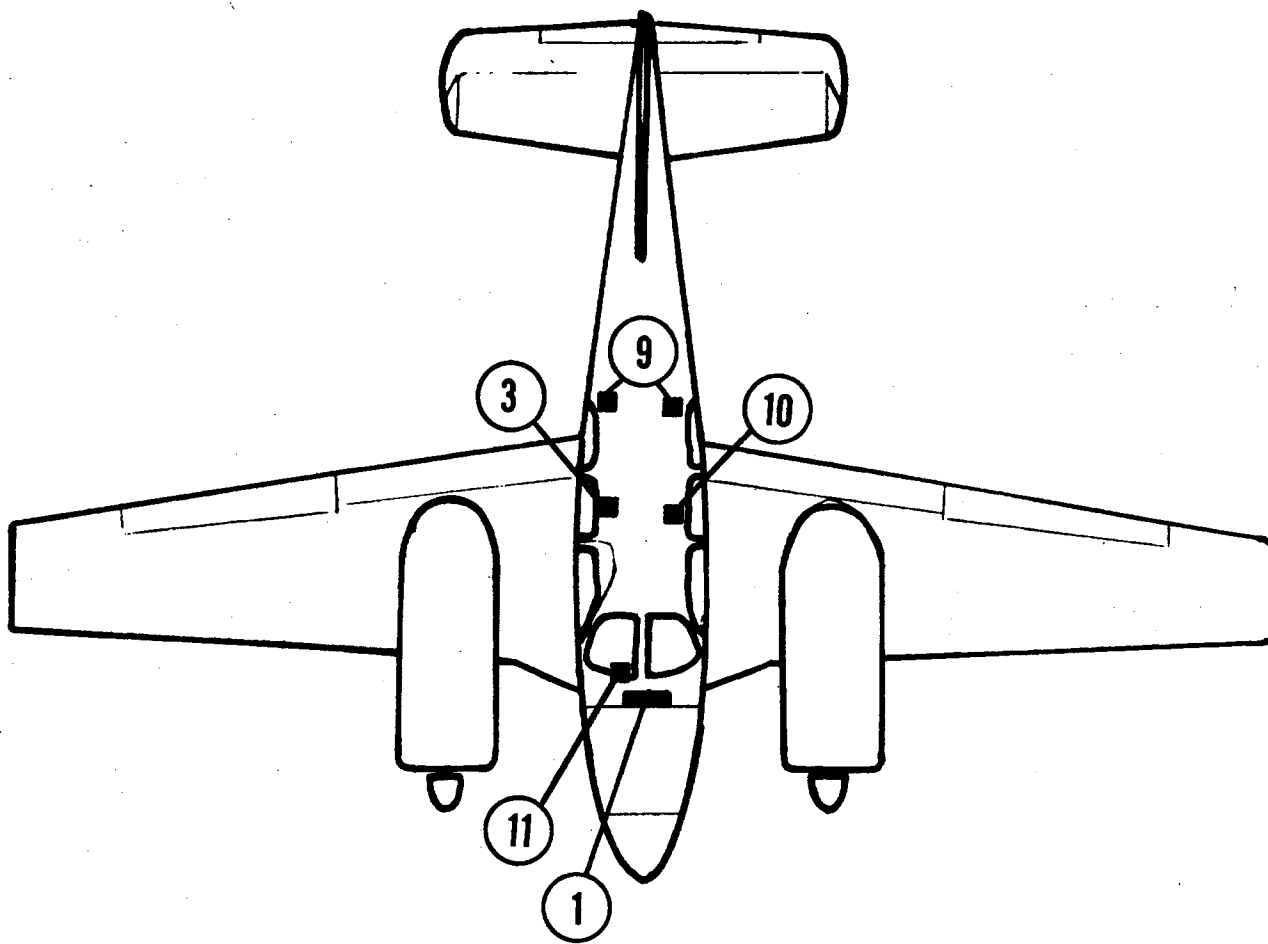

AK408

BEECH BARON

95-55, 95-A55, 95-B55, 95-C55, 95-B55B,
D55, D55A, E55, E55A, 56TC and A56TC

CENTURY II

AK408
STC SA1565SW

BEECH MODELS 95-55, 95-A55, 95-B55,
95B55B, 95-C55, D55, E55, 56TC and A56TC

PART DESCRIPTION AND NOMENCLATURE	LOCATION
Console-Amplifier 1C385-24	(1) Instrument panel
Artificial Horizon 52D66	(1) Instrument panel
Directional Gyro 52D54	(1) Instrument panel
Roll Servo 1C465-1-194R	(3) In front of rear spar, under floor, beneath center seats, co-pilot's side
Main Cable Harness 30C198	
Radio Coupler (Opt.) 1C388-M	(1) Instrument panel
Stabilizer (Opt.) 1C359	(9) Beneath aft baggage floor, either side of aircraft
Switch Box 1B405-24	(10) Under floor, just forward of rear spar, left side
Inverter 48A17	(11) Right side of throttle control pedestal.

SERVICING DATA

Roll Servo Clutch Setting (lbs): 43 ± 7

Pitch Servo Clutch Setting (lbs):

Pitch Trim Servo Clutch Setting (lbs):

Trim Sensor Point Gap (in.):

Bridle Cable(s): Roll - 30B221

Limitations Placard Part Number: 13A344-196

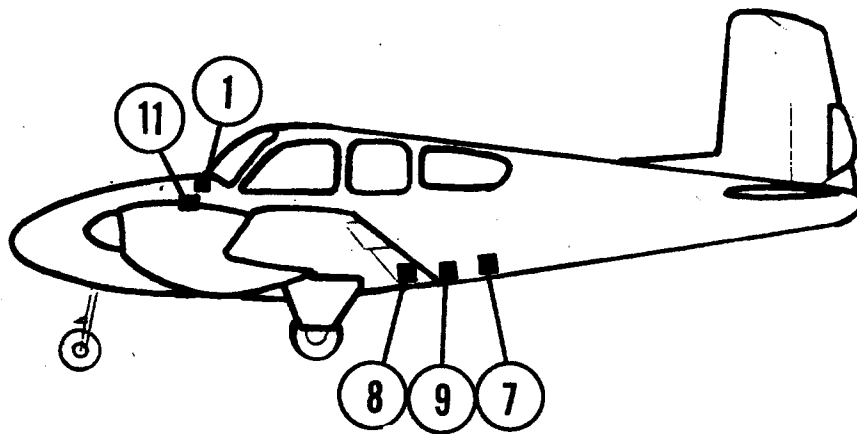
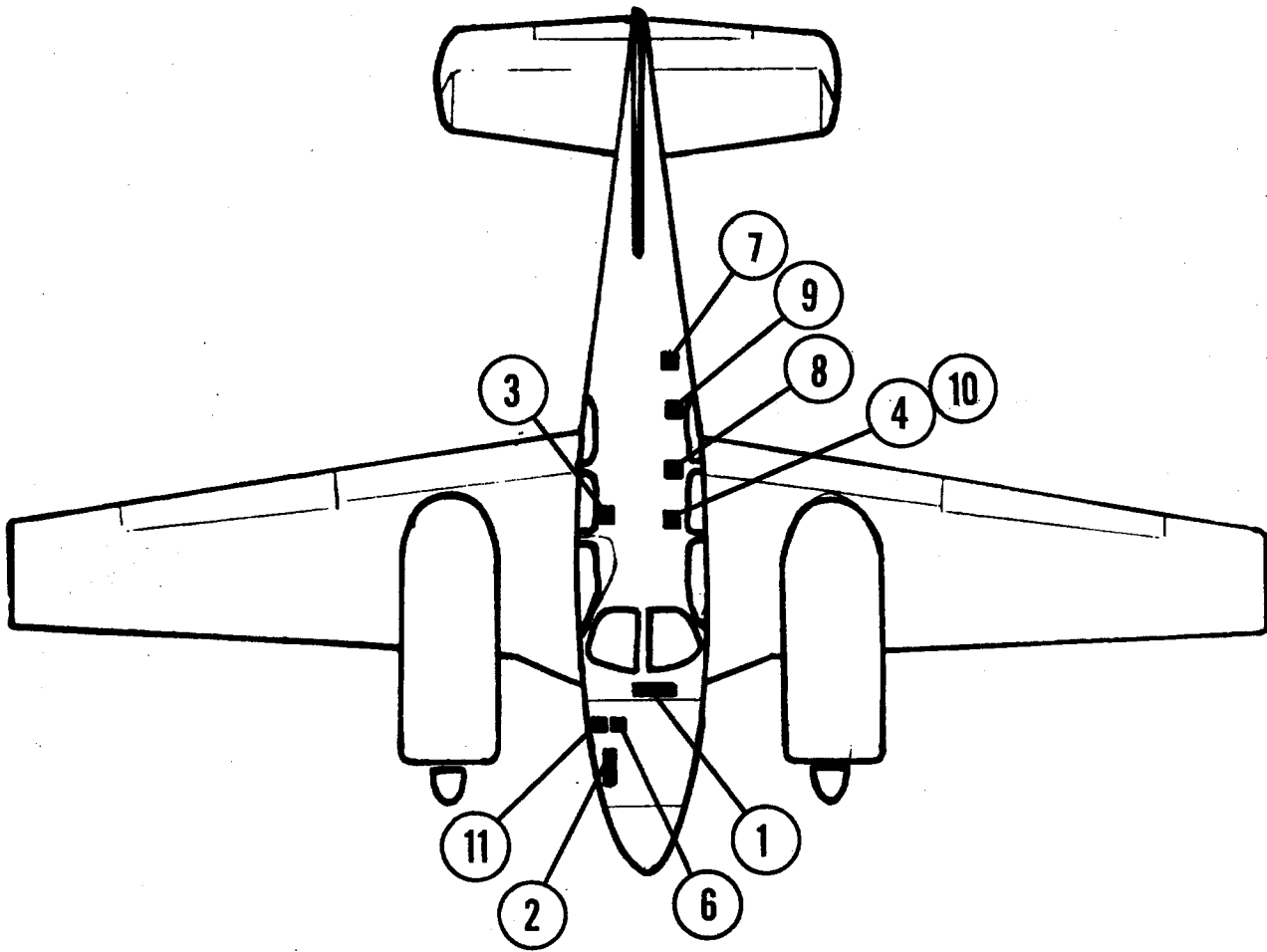

AK194

BEECH

BARON

56TC and A56TC

CENTURY III

AK194
STC SA617SW

BEECH 56TC AND A56TC

PART DESCRIPTION AND NOMENCLATURE	LOCATION
PITCH SIGNAL FILTER. 1B440-1	(1) Under instrument panel near artificial horizon
CONSOLE 1C404	(1) Upper portion radio panel
ARTIFICIAL HORIZON 52D67	(1) Instrument panel
DIRECTIONAL GYRO 52D54	(1) Instrument panel
ROLL SERVO 1C465-1-194R	(3) In front of rear spar under floor, co-pilot's side
PITCH SERVO 1C477-194P	(4) In front of rear spar, pilot's side
ALTITUDE HOLD 1C470	(6) Lower center of instrument panel and forward cabin bulkhead, co-pilot's side
MAIN CABLE HARNESS 30D207-4	
GYRO-AMPLIFIER 1C359	(9) Beneath aft baggage floor, left side
RADIO COUPLER 1C388-M	(1) Instrument panel
TRIM SERVO 1C469-1-194	(7) In aft fuselage behind baggage compartment, pilot's side
TRIM SENSOR 1C318-194	(8) Under floor aft of rear wing spar, pilot's side
AMPLIFIER 1D395	(2) Co-pilot's side, aft corner of nose baggage compartment or forward side of forward cabin bulkhead or radio rack in nose baggage compartment
SWITCH BOX 1B405-24	(10) Under floor in front of rear spar, near pitch servo, pilot's side
INVERTER 48C17	(11) Under instrument panel and forward cabin bulkhead or on radio rack forward nose baggage compartment or forward side of forward cabin bulkhead, co-pilot's side

SERVICING DATA

Roll Servo Clutch Setting (lbs): 43 ± 7
 Pitch Servo Clutch Setting (lbs): 13 ± 2
 Pitch Trim Servo Clutch Setting (lbs): $26 \begin{smallmatrix} +6 \\ -7 \end{smallmatrix}$
 Trim Sensor Point Gap (in.): $.014 \pm .002$
 Bridle Cable(s): Roll - 30B221 Pitch - 30B222
 Limitations Placard Part Number: 13A329-194

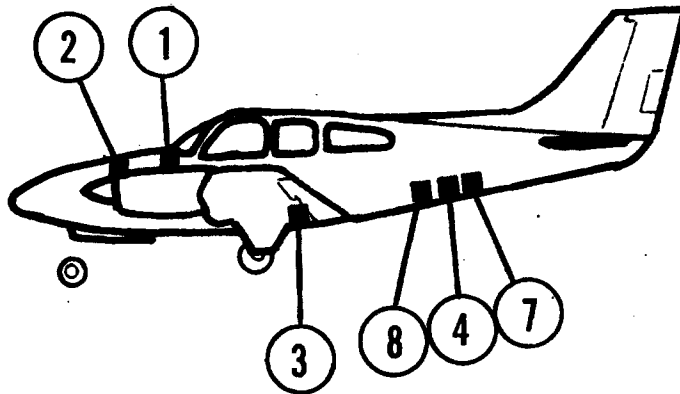
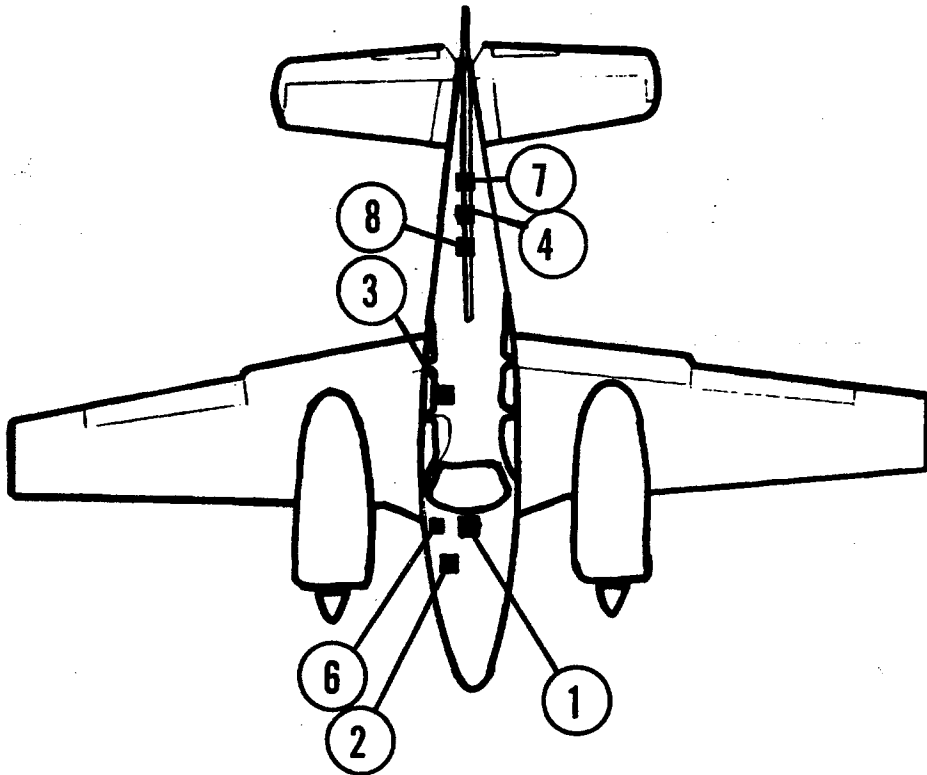

AK303

BEECH

BARON

58 and 58A

CENTURY III

AK303
STC SA1175SW

BEECH 58 and 58A

PART DESCRIPTION AND NOMENCLATURE	LOCATION
CONSOLE 1C404	(1) Upper portion of radio panel
ARTIFICIAL HORIZON 52D67-M	(1) Instrument panel
DIRECTIONAL GYRO 52D54-M	(1) Instrument panel
ROLL SERVO 1C465-1-303R	(3) Under floor, forward edge of rear spar, right side of A/C
PITCH SERVO 1C470-1-303P	(4) Aft of rear baggage compartment between second and third bulkheads on C/L
ALTITUDE HOLD 1C407	(6) Between lower center of instrument panel and forward cabin bulkhead, co-pilot's side
MAIN CABLE HARNESS 30D207-4	
RELAY BOX 1A526-1	(5) Under instrument panel
RADIO COUPLER 1C388-M	(1) Instrument panel
GLIDE SLOPE COUPLER 1C493	(1) Under instrument panel within 3 feet of artificial horizon
G.S. COUPLER HARNESS 30C291	
TRIM SERVO 1C469-1-303	(7) Aft of rear baggage compartment at Station bulkhead 207, right side of C/L
TRIM SENSOR 1C647-303	(8) At second bulkhead aft of the rear baggage compartment, on C/L of A/C
TRIM SWITCH 30A364	Pilot's control wheel
TRIM AMP 1C646-28	Aft of rear baggage compartment at Station bulkhead 207, right side of C/L
AMPLIFIER 1C515-1	(2) Aft corner of nose baggage compartment co-pilot's side, or forward side of forward cabin bulkhead, or the radio rack in nose baggage compartment

SERVICING DATA

Roll Servo Clutch Setting (lbs): $45 \begin{smallmatrix} +5 \\ -6 \end{smallmatrix}$
 Pitch Servo Clutch Setting (lbs): $24 \begin{smallmatrix} +3 \\ -4 \end{smallmatrix}$
 Pitch Trim Servo Clutch Setting (lbs): $25 \begin{smallmatrix} +5 \\ -2 \end{smallmatrix}$
 Trim Sensor Point Gap (in.): $.007 \pm .002$
 Bridle Cable(s): Roll - 30B221 Pitch - 30B263
 Limitations Placard Part Number: See AFM Supplement

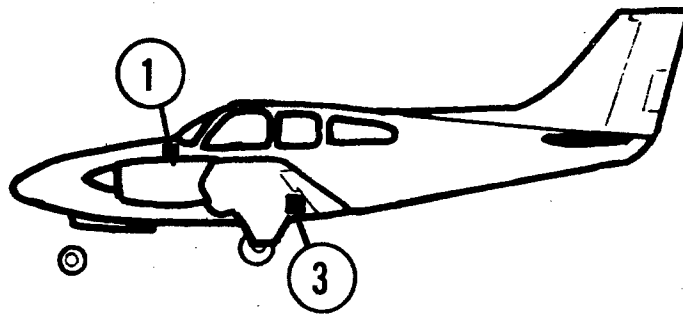
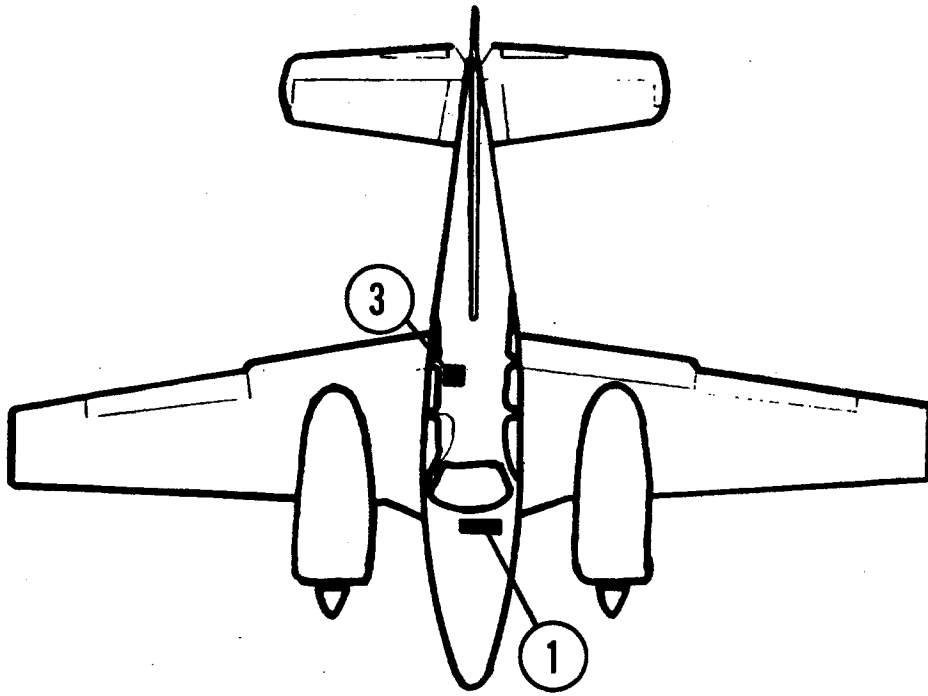

AK305

BEECH

BARON

58 and 58A

CENTURY II

AK305
STC SA1199SW

BEECH 58 AND 58A

PART DESCRIPTION AND NOMENCLATURE	LOCATION
CONSOLE-AMPLIFIER 1C385-24	(1) Instrument panel
ROLL SIGNAL FILTER 1B440	(1) Under instrument panel near artificial horizon
ARTIFICIAL HORIZON 52D66	(1) Instrument panel
DIRECTIONAL GYRO 52D54	(1) Instrument panel
ROLL SERVO 1C465-1-303R	(3) Forward edge of rear spar, right side, beneath center seats.
MAIN CABLE HARNESS 30C198	
RADIO COUPLER (OPT.) 1C388-M	(1) Instrument panel

SERVICING DATA

Roll Servo Clutch Setting (lbs): 45 +5
 Pitch Servo Clutch Setting (lbs): -6
 Pitch Trim Servo Clutch Setting (lbs):
 Trim Sensor Point Gap (in.):
 Bridle Cable(s): Roll - 30B221
 Limitations Placard Part Number: 13A344-305

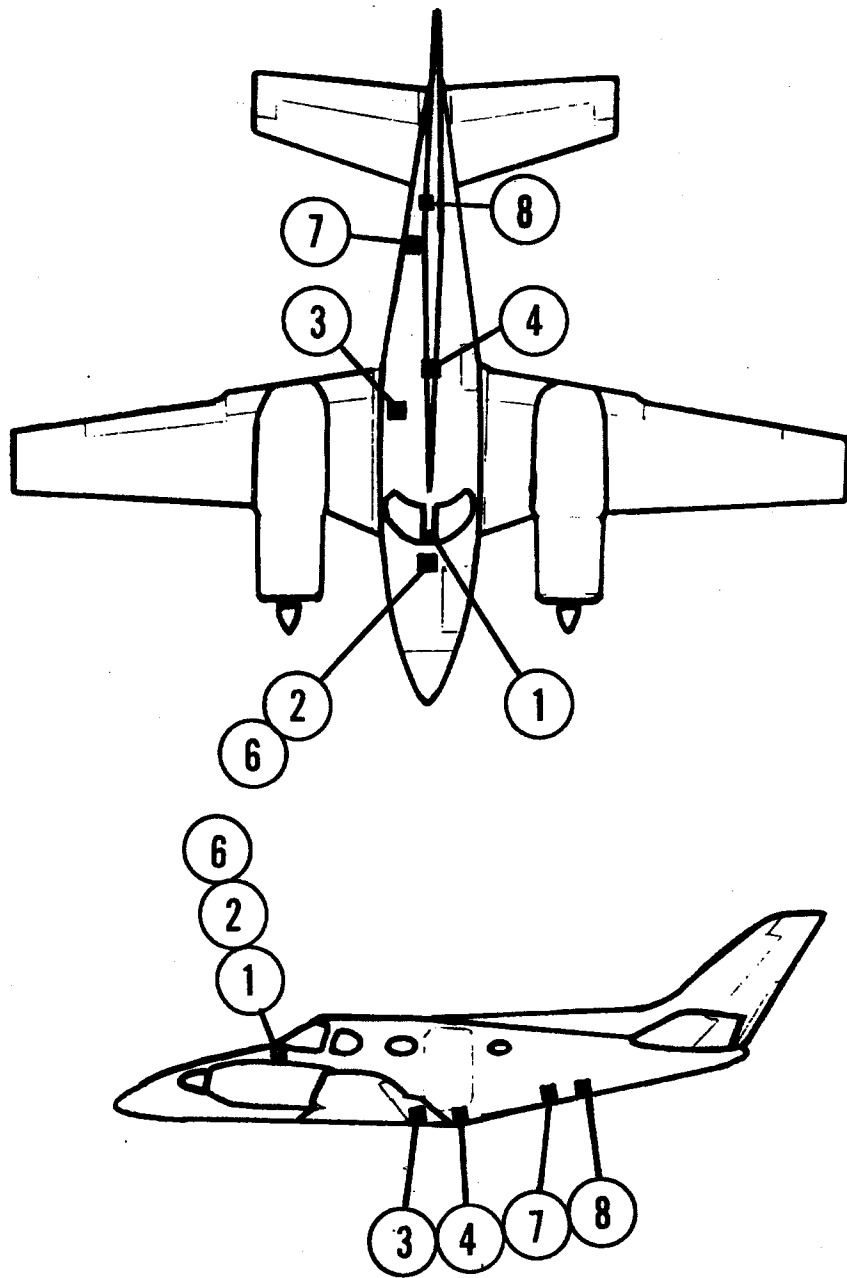

AK291

BEECH

DUKE

60, A60

CENTURY III

AK291
STC SA1006SW

BEECH 60 AND A60

PART DESCRIPTION AND NOMENCLATURE	LOCATION
<p>CONSOLE 1C404 OR *1C404-1</p> <p>ARTIFICIAL HORIZON 52D67</p> <p>DIRECTIONAL GYRO 52D54</p> <p>ROLL SERVO 1C465-1-291R</p> <p>PITCH SERVO 1C470-1-291P</p> <p>ALTITUDE HOLD 1C407</p> <p>MAIN CABLE HARNESS 30D207-4</p> <p>RADIO COUPLER 1C388-M</p> <p>TRIM SERVO 1C469-1-291</p> <p>TRIM SENSOR 1D474-291</p> <p>AMPLIFIER 1C515-1</p>	<p>(1) In center pedestal, immediately below throttle quadrant</p> <p>(1) Instrument panel</p> <p>(1) Instrument panel</p> <p>(3) In aft wing spar box just left of aircraft centerline</p> <p>(4) Just forward of bulkhead at Station 214.0, under floor, on centerline</p> <p>(6) On instrument panel support, directly forward of mixture levers</p> <p>(1) Instrument panel</p> <p>(7) In aft fuselage, just aft of Station 265.0, right side</p> <p>(8) In aft fuselage, aft of Station 288.0 on C/L of Aircraft</p> <p>(2) Under instrument panel, just aft of firewall, right side</p>
<p>* 1C404-1 CONSOLE specially built for BEECH Factory only. (Has additional pigtail connection)</p>	

SERVICING DATA

Roll Servo Clutch Setting (lbs): 43 ± 8
 Pitch Servo Clutch Setting (lbs): 21 ± 4
 Pitch Trim Servo Clutch Setting (lbs): 37 ± 3
 Trim Sensor Point Gap (in.): $.010 \pm .002$
 Bridle Cable(s): Roll - 30B383 Pitch - 30B350
 Limitations Placard Part Number: See AFM Supplement

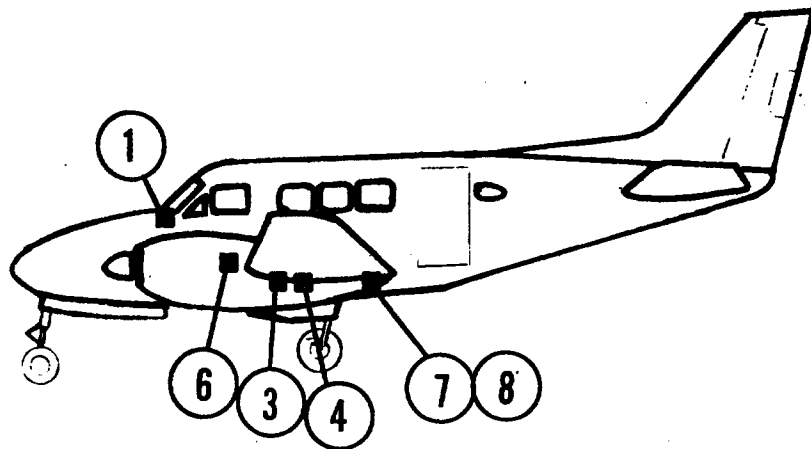
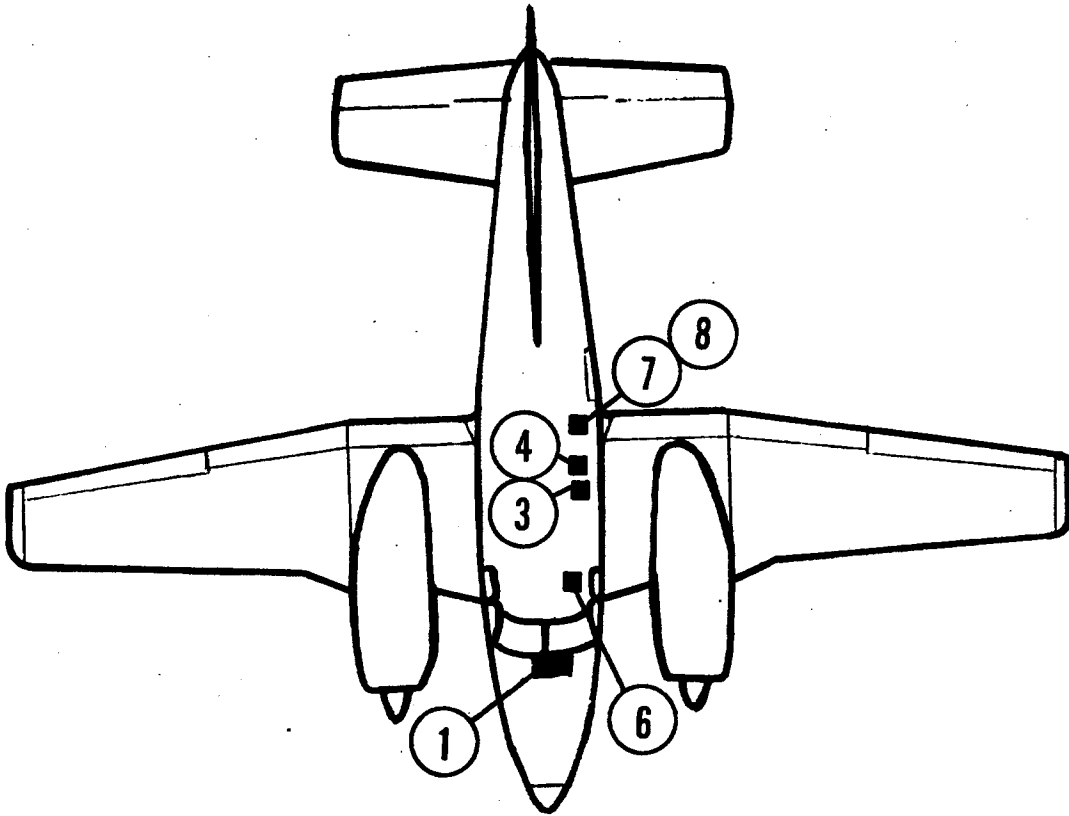

AK239

BEECH

QUEENAIR

65, A65, 65-80, 65-A80, 65-A80-8800
65-B80, A65-8200, 70

CENTURY III

AK239
STC SA767SW

BEECH 65, A65, 65-80, 65-A80
65-A80-8800, 65-B80 AND A65-8200 & 70

703

PART DESCRIPTION AND NOMENCLATURE	LOCATION
CONSOLE 1C404	(1) In center pedestal
ARTIFICIAL HORIZON 52D67	(1) Instrument panel
DIRECTIONAL GYRO 52D54	(1) Instrument panel
ROLL SERVO 1C465-1-239R	(3) Inside first access hole aft of main spar, pilot's side of aircraft
PITCH SERVO 1C465-1-239P	(4) Installed in next bay, aft of roll servo, pilot's side
ALTITUDE HOLD 1C407	(6) Mounted to floor under pilot's seat
MAIN CABLE HARNESS 30D207-2	
RADIO COUPLER 1C388-M	(1) Instrument panel
TRIM SERVO 1C469-1-239	(7) Under floor in first compartment forward of passenger compartment door, pilot's side
TRIM SENSOR 1C365-239	(8) In round access hole just forward of door between seat tracks, pilot's side
AMPLIFIER 1D395	(2) On third inspection plate, pilot's side, aft of main spar

SERVICING DATA

Roll Servo Clutch Setting (lbs): 55 ± 5
 Pitch Servo Clutch Setting (lbs): 22 ± 2
 Pitch Trim Servo Clutch Setting (lbs): 21 ± 3
 Trim Sensor Point Gap (in.): $.010 \pm .002$
 Bridle Cable(s): Roll - 30B252 Pitch - 30B253
 Limitations Placard Part Number: See AFM Supplement

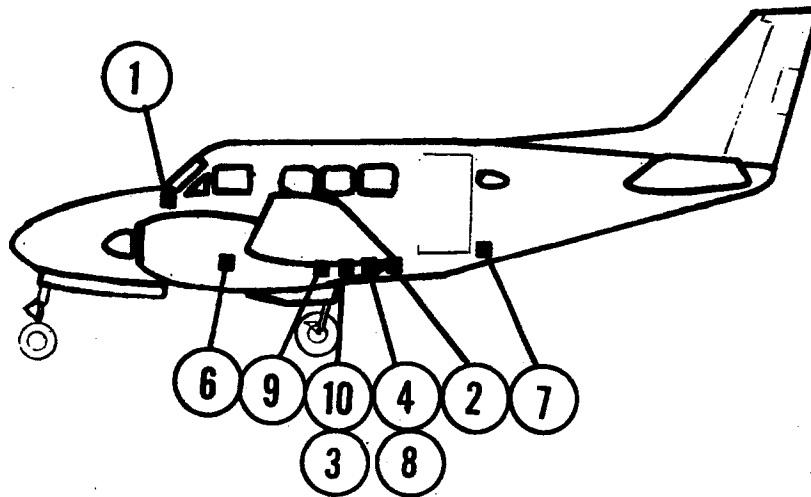
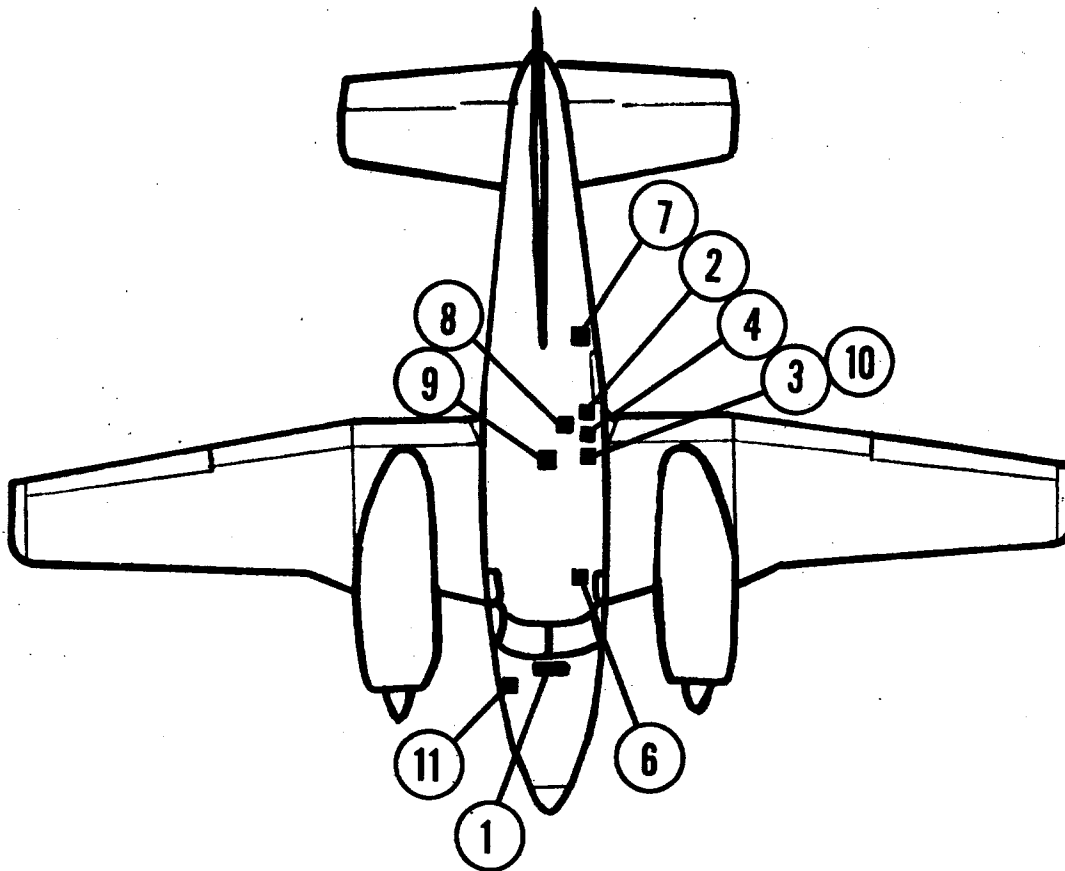

AK206

BEECH QUEENAIR

65-88

CENTURY III

AK206
STC SA651SW

BEECH 65-88 Queenair

PART DESCRIPTION AND NOMENCLATURE	LOCATION
<p>CONSOLE 1C404</p> <p>ARTIFICIAL HORIZON 52D67</p> <p>DIRECTIONAL GYRO 52D54</p> <p>ROLL SERVO 1D414-206R</p> <p>PITCH SERVO 1D414-206P</p> <p>ALTITUDE HOLD 1C407</p> <p>MAIN CABLE HARNESS 30D207-2</p> <p>GYRO-AMPLIFIER 1C359</p> <p>RADIO COUPLER 1C388-M</p> <p>TRIM SERVO 1D457-206</p> <p>TRIM SENSOR 1C365-206</p> <p>AMPLIFIER 1D395</p> <p>SWITCH BOX 1B405-24</p> <p>INVERTER 48C17</p>	<p>(1) In center pedestal</p> <p>(1) Instrument panel</p> <p>(1) Instrument panel</p> <p>(3) Inside first access hole aft of main spar, pilot's side</p> <p>(4) In next bay aft of roll servo, pilot's side</p> <p>(6) On floor beneath pilot's seat</p> <p>(9) Beneath center walkway just aft of rear spar</p> <p>(1) Instrument panel</p> <p>(7) On bulkhead, aft side of oblong access hole, pilot's side, pax entrance</p> <p>(8) Round access hole just forward of door between seat tracks, pilot's side</p> <p>(2) On third inspection plate aft of main spar, pilot's side</p> <p>(10) Beneath floor above roll servo, pilot's side</p> <p>(11) On forward cabin bulkhead, co-pilot's side</p>

SERVICING DATA

Roll Servo Clutch Setting (lbs): 55 ± 5
 Pitch Servo Clutch Setting (lbs): 22 ± 2
 Pitch Trim Servo Clutch Setting (lbs): 21 ± 3
 Trim Sensor Point Gap (in.): $.010 \pm .002$
 Bridle Cable(s): Roll - 30B252 Pitch - 30B253
 Limitations Placard Part Number: See AFM Supplement

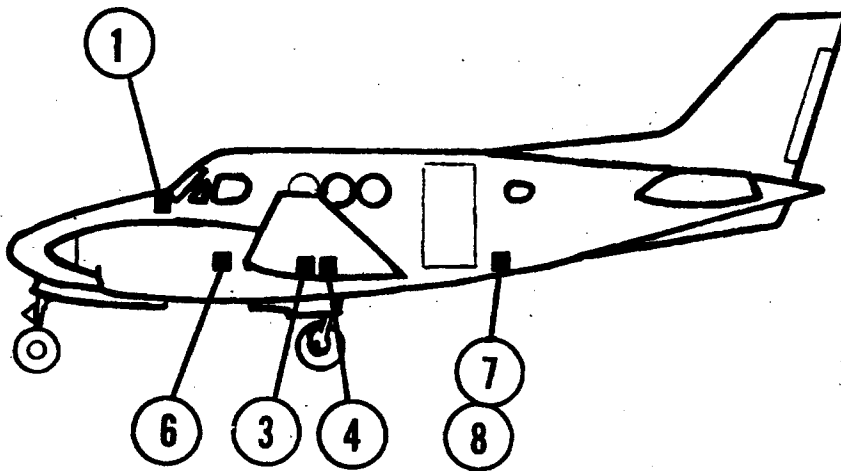
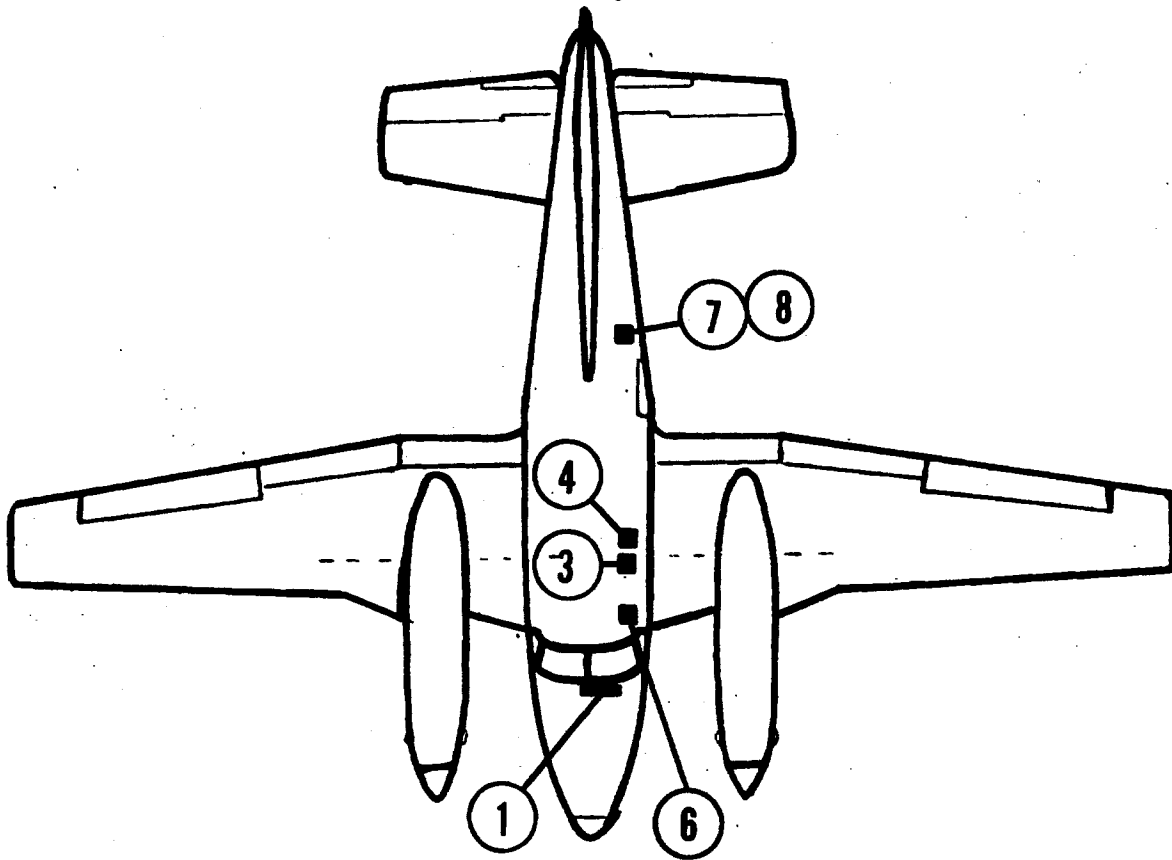

AK238

BEECH

KINGAIR

65-90, 65-A90

CENTURY III

AK238
STC SA761SW

BEECH 65-90 and 65A90

PART DESCRIPTION AND NOMENCLATURE	LOCATION
PITCH SIGNAL FILTER 1B440-1	(1) Under instrument panel
CONSOLE 1C404	(1) In center pedestal
ARTIFICIAL HORIZON 52D67	(1) Instrument panel
DIRECTIONAL GYRO 52D54	(1) Instrument panel
ROLL SERVO 1D414-206R	(3) Inside first access hole, aft of main spar on pilot's side
PITCH SERVO 1D414-238P	(4) Next bay aft of roll servo, on pilot's side
ALTITUDE HOLD 1C407	(6) To floor beneath pilot's seat
MAIN CABLE HARNESS 30D207-2	
RADIO COUPLER 1C388-M	(1) Instrument panel
TRIM SERVO 1D457-206	(7) On bulkhead, aft side of oblong access hole, pilot's side.
TRIM SENSOR 1C365-238	(8) Same access hole with pitch trim servo
AMPLIFIER 1D395	(2) Mounted on third inspection plate, pilot's side, aft of main spar

SERVICING DATA

Roll Servo Clutch Setting (lbs): 55 ± 5
 Pitch Servo Clutch Setting (lbs): 16 ± 2
 Pitch Trim Servo Clutch Setting (lbs): 21 ± 3
 Trim Sensor Point Gap (in.): $.010 \pm .002$
 Bridle Cable(s): Roll - 30B252 Pitch - 30B253
 Limitations Placard Part Number: See AFM Supplement

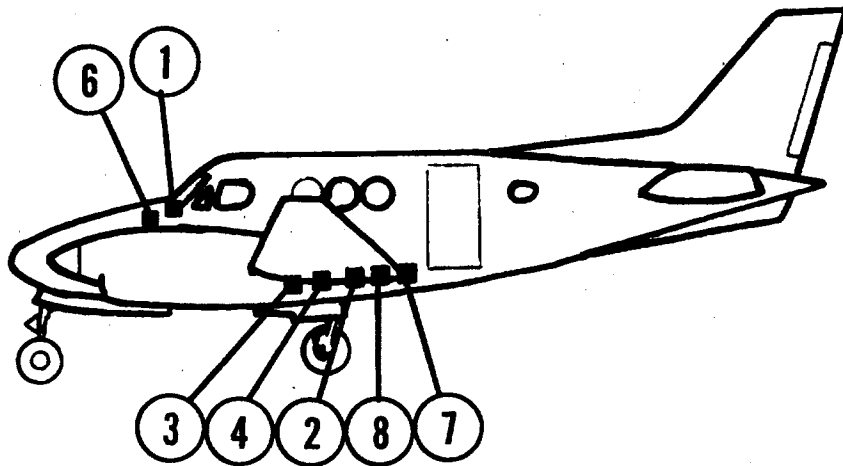
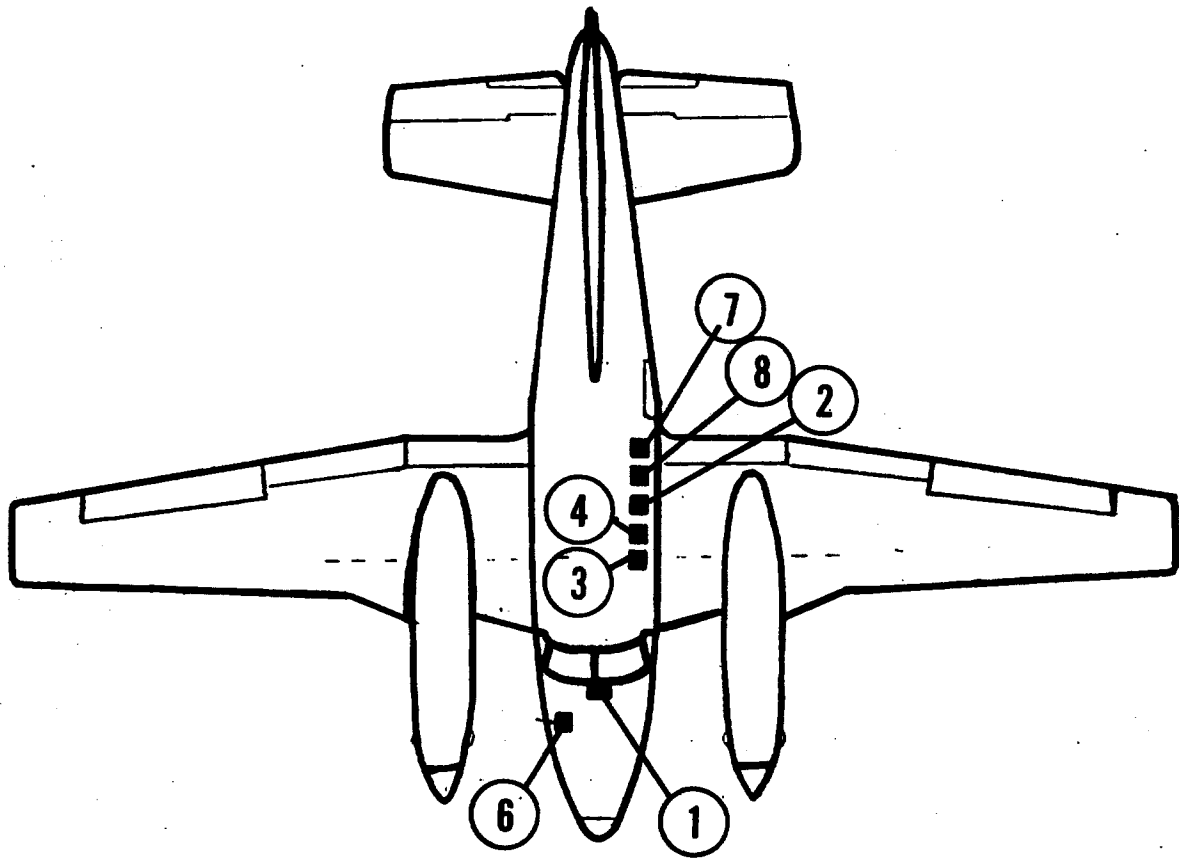

AK318

BEECH KING AIR

B90, C90

CENTURY III

AK318
STC SA1458SW

BEECH B90 AND C90 King Air

PART DESCRIPTION AND NOMENCLATURE	LOCATION
CONSOLE 1C404	(1) On center pedestal
ARTIFICIAL HORIZON 52D67	(1) Instrument panel
DIRECTIONAL GYRO 52D54	(1) Instrument panel
ROLL SERVO 1C465-1-318R	(3) Under floor, first bay aft of main spar left side of A/C
PITCH SERVO 1C470-1-318P	(4) Second bay aft of mainspar, aft side of bulkhead, at Station 176.50, under floor, left side
ALTITUDE HOLD 1C470	(6) On forward cabin pressure bulkhead Station 84.00 right side
MAIN CABLE HARNESS 30D207-2	
RELAY BOX 1A526-1	(5) Under instrument panel
RADIO COUPLER 1C388	(1) Instrument panel
GLIDE SLOPE COUPLER 1C493	(1) Behind instrument panel, within 3 feet of artificial horizon
G.S. COUPLER HARNESS 30C291	
TRIM SERVO 1C469-318	(7) Second bay forward of forward cabin door post under floor, left side, Station 216.00
* TRIM SENSOR 1C655-318	(8) Under floor, left side just forward of bulkhead station 216.00
AMPLIFIER 1C515-1	(2) On third inspection plate aft of main spar, pilot's side

SERVICING DATA

Roll Servo Clutch Setting (lbs): 35 ± 5
 Pitch Servo Clutch Setting (lbs): 23 ± 3
 Clutch Trim Servo Clutch Setting (lbs): 17 ± 2
 Trim Sensor Point Gap (in.): Bracket No. 1: $.010$ *(CD-100) Bracket No. 2: $.010$ *(CD-41)
 Limitations Placard Part Number: See AFM Supplement
 Bridle Cable(s): Roll - 30B442 Pitch - 30B253

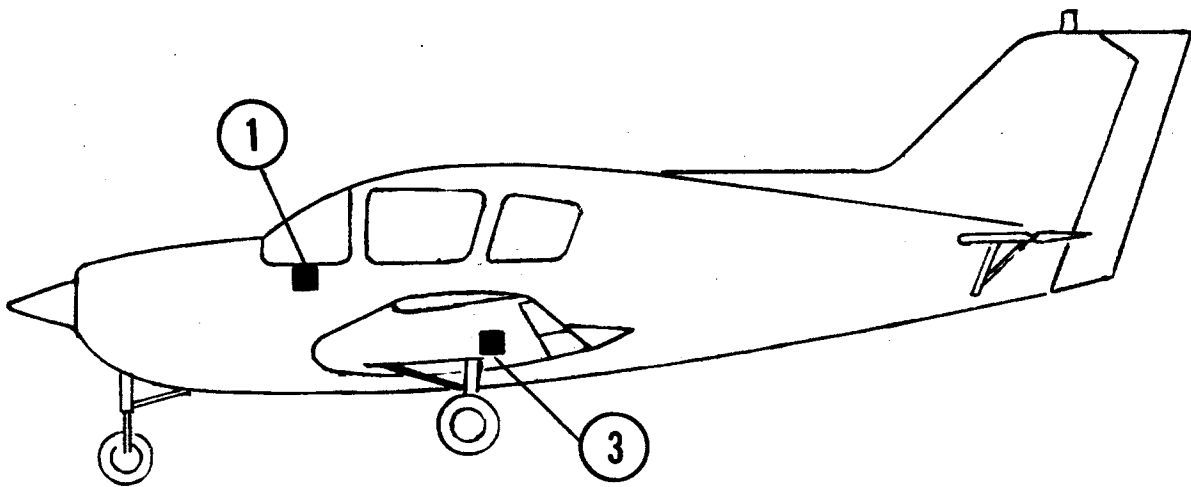
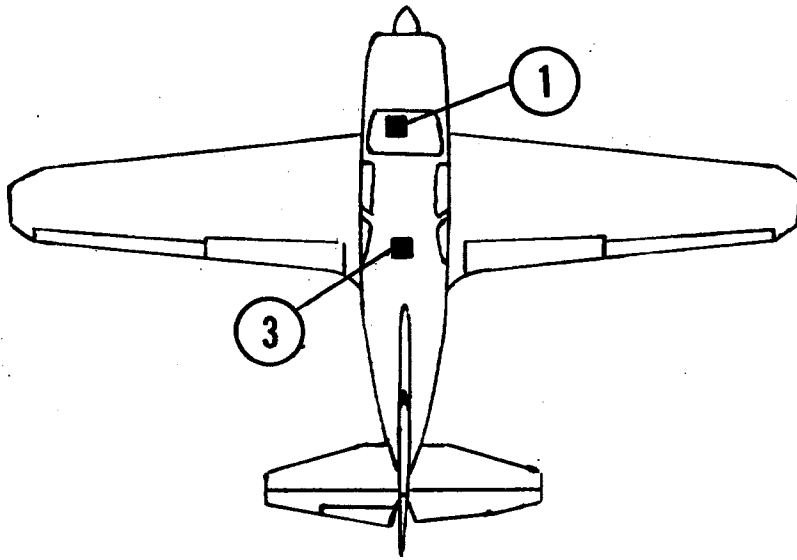

AK215

BELLANCA · CRUISEMASTER 14-19-3, 14-19-3A, 17-30, 17-30A,
17-31A, 17-31TC, 17-31ATC, 17-31

CENTURY II

AK215
STC SA645SW

BELLANCA 14-19-3A, 17-30, 17-31, 17-31TC,
17-30A, 17-31A, 17-31ATC

PART DESCRIPTION AND NOMENCLATURE	LOCATION
Console-Amplifier 1C385	(1) Pilot's side instrument panel
Roll Signal Filter 1B440	(1) Under instrument panel near artificial horizon
Artificial Horizon 52D66	(1) Instrument panel
Directional Gyro 52D54	(1) Instrument panel
Roll Servo 1D456-215R	(3) Under rear seat, on center line
Main Cable Harness 30C198	
Radio Coupler (Opt.) 1C388	(1) Instrument panel
<p>NOTES: 14-19-3A, 17-30, 17-30A, 17-31 and 17-31A Manual Electric Trim AK276</p>	

SERVICING DATA

Roll Servo Clutch Setting (lbs): 35 ± 5

Pitch Servo Clutch Setting (lbs):

Pitch Trim Servo Clutch Setting (lbs):

Trim Sensor Point Gap (in.):

Bridle Cable(s): Roll - 30B251

Limitations Placard Part Number: 13A344-215

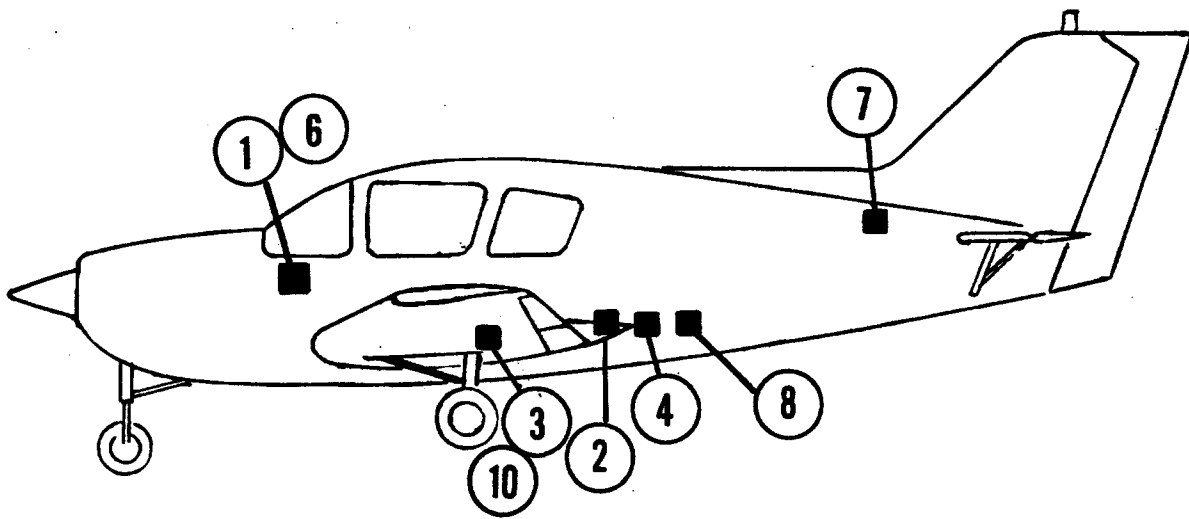
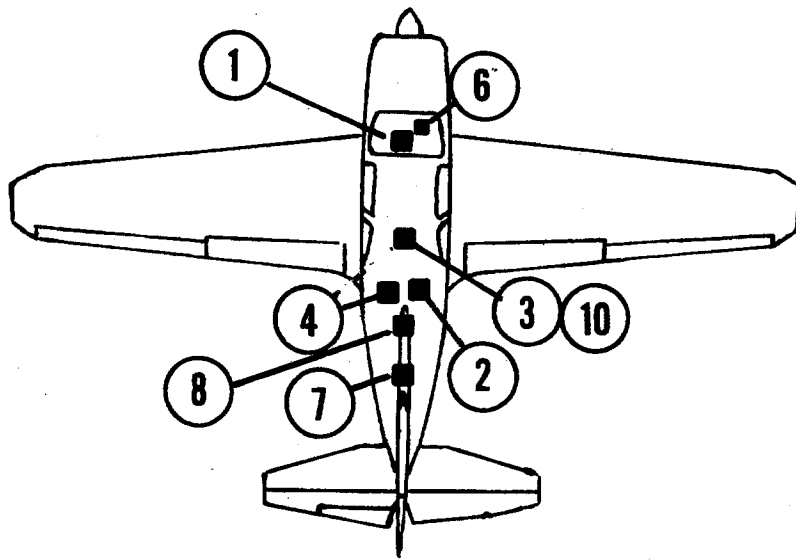

AK233

BELLANCA CRUISEMASTER VIKING AND SUPER VIKING
 14-19-3, 14-19-3A, 17-30, 17-30A, 17-31A, 17-31TC,
 17-31ATC, 17-31

CENTURY III

AK233
STC SA869SW
STC SA 1236SW (17-30A models and up)

BELLANCA 14-19-3A, 17-30, 17-31
17-31TC, 17-30A, 17-31A and 17-31 ATC

PART DESCRIPTION AND NOMENCLATURE	LOCATION
ROLL SIGNAL FILTER 1B440 (if using 1D395)	(On cross tube brace behind installation panel) (1) Instrument panel
CONSOLE 1C404	(1) Instrument panel
ARTIFICIAL HORIZON 52D67	(1) Instrument panel
DIRECTIONAL GYRO 52D54	(1) Instrument panel
ROLL SERVO 1C363-1-233R	(3) Under rear seat, on centerline
PITCH SERVO 1C508-1-233P	(4) Under baggage floor, pilot's side
ALTITUDE HOLD 1C407	(6) Under instrument panel, pilot's side
MAIN CABLE HARNESS 30D207-11	
RELAY BOX 1B405	(10) Under rear seat near roll servo
GYRO-AMPLIFIER 1C359	Aft of baggage compartment floor, center
RADIO COUPLER 1C388	(1) Instrument panel
TRIM SERVO 1C373-3-233	(7) Aft fuselage just beneath forward portion of vertical fin
TRIM SENSOR 1C501	(8) Beneath baggage compartment on centerline
TRIM SWITCH 30A204	Pilot's control wheel
AMPLIFIER 1D395 OR 1C515-1	(2) Under baggage compartment or under instrument panel co-pilot's side

SERVICING DATA

Roll Servo Clutch Setting (lbs): 35 ± 5
 Pitch Servo Clutch Setting (lbs): 27^{+3}_{-4}
 Pitch Trim Servo Clutch Setting (lbs): 14 ± 4
 Trim Sensor Point Gap (in.): $.050 \pm .002$
 Bridle Cable(s): Roll - 30B251 Pitch - 30B242
 Limitations Placard Part Number: See AFM Supplement

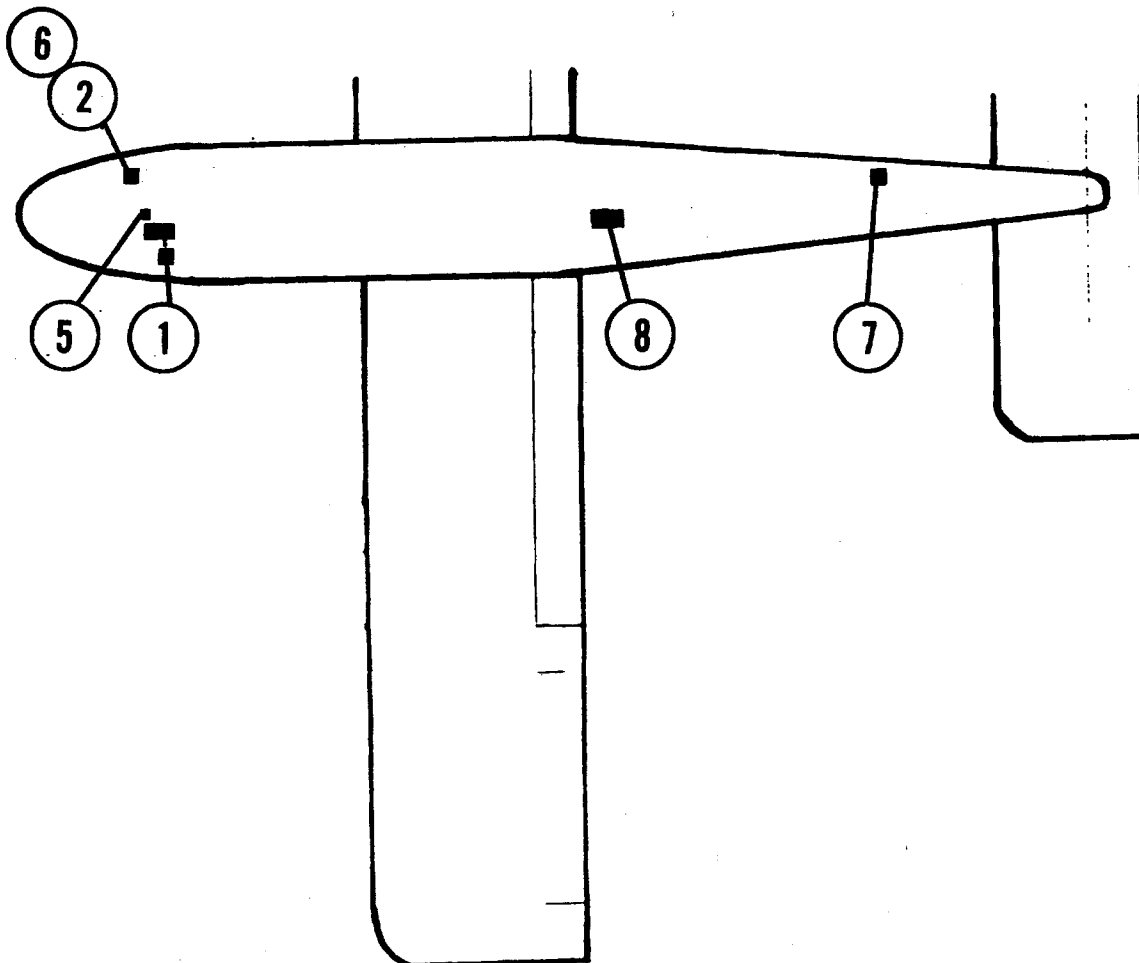
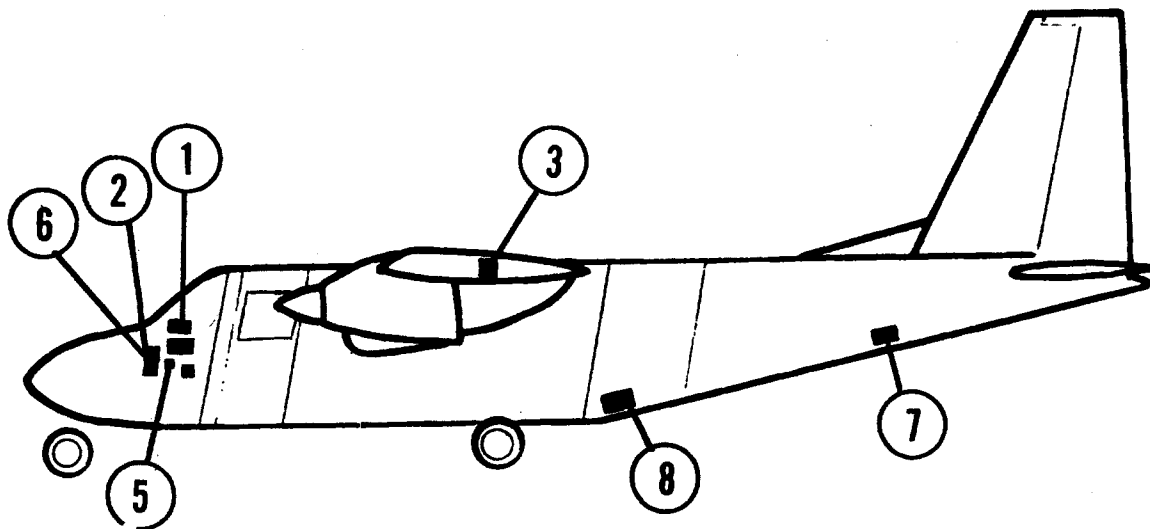

AK336

BRITTEN-NORMAN ISLANDER BN-2, BN-2A, BN-2A-6

BRITTEN-NORMAN

CENTURY III

AK336
STC SA1312SW

ISLANDER BN-2, BN-2A AND BN-2A-6

PART DESCRIPTION AND NOMENCLATURE	LOCATION
CONSOLE 1C404	(1) Lower left portion of instrument panel
ARTIFICIAL HORIZON 52D67	(1) Instrument panel
DIRECTIONAL GYRO 52D54	(1) Instrument panel
ROLL SERVO 1C465-1-336R	(3) Above passenger door on left (pilot's side) of A/C, approximately 10" aft rear spar
PITCH SERVO 1C678-1-336P	(4) Between Station 219.25 and 255.25 just aft of baggage compartment
ALTITUDE HOLD 1C407-1	(6) Forward of instrument panel to bulkhead at Station 46.00, co-pilot's side
MAIN CABLE HARNESS 30D207-4	
RELAY BOX 1A526-1	(5) Under instrument panel
RADIO COUPLER 1C388	(1) Instrument panel
GLIDE SLOPE COUPLER 1C493	(1) Behind instrument panel within 3 feet of artificial horizon
G.S. COUPLER HARNESS 30C291	
TRIM SERVO 1C469-5-336	(7) Between two bulkheads at Stations 312.45 and 352.40
TRIM SENSOR 1C678-1-336P	(8) Between Stations 219.25 and 255.25 just aft of baggage compartment
TRIM SWITCH 30B416	On pilot's control wheel
AMPLIFIER 1C515-2	(2) Forward of instrument panel to bulkhead at Station 46.00, co-pilot's side

SERVICING DATA

Roll Servo Clutch Setting (lbs): $33 \pm \frac{7}{8}$

Pitch Servo Clutch Setting (lbs): 37 ± 4

Pitch Trim Servo Clutch Setting (lbs): 30 ± 5

Trim Sensor Point Gap (in.): Bracket No. 1:
 $.045 \pm .005$ (CD-41)

Bracket No. 2
 $.020 \pm .005$ (CD-100)

Limitations Placard Part Number: See AFM Supplement

Bridle Cable (s): Roll - 30B383 Pitch - N/A

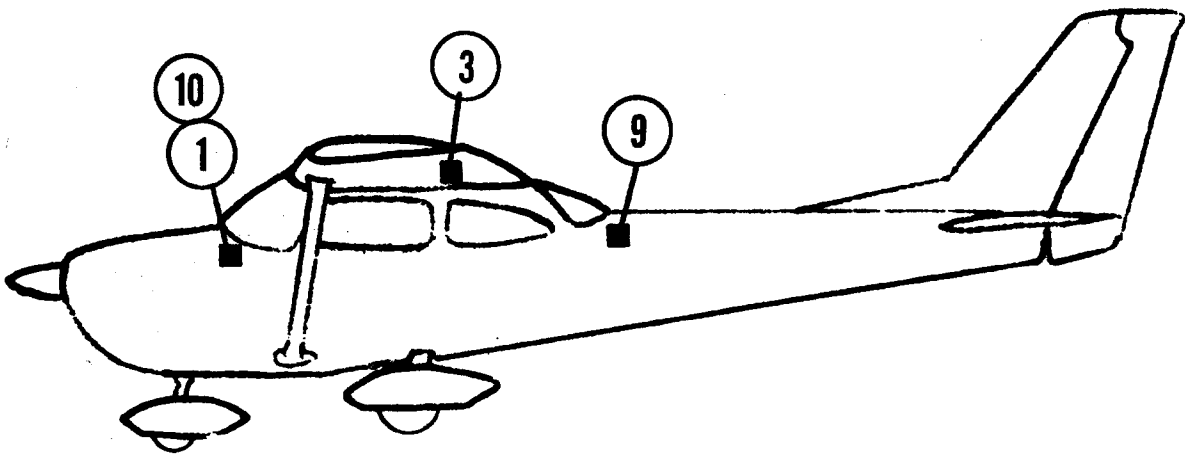
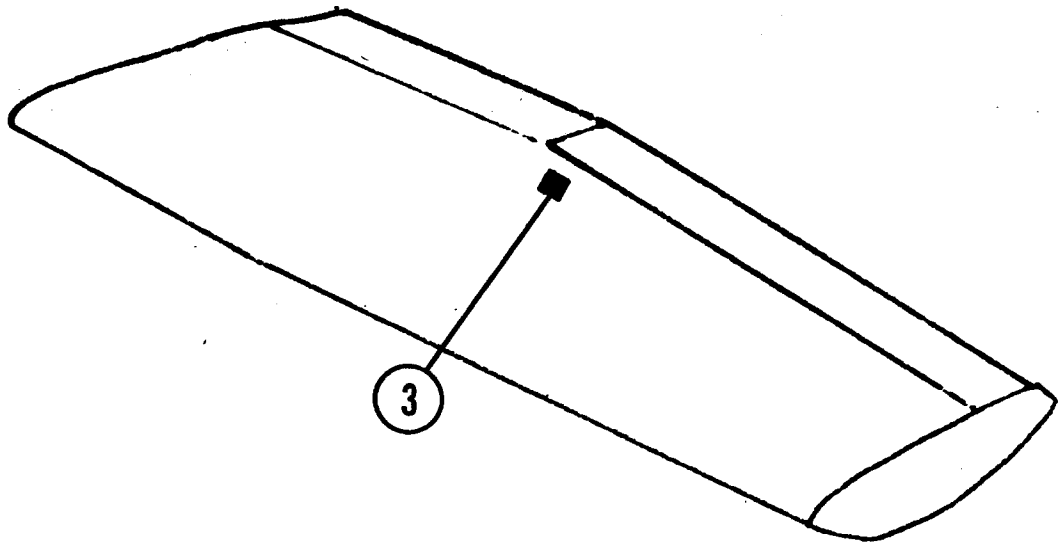

AK191

CESSNA

172D, 172E, 172F, 172G, 172H, 172I,
172K, 172L

CENTURY II

AK191
STC SA603SW

CESSNA 172D, 172E, 172F, 172G, 172H,
172I, 172J, 172K and 172L

PART DESCRIPTION AND NOMENCLATURE	LOCATION
Console-Amplifier 1C385	(1) Instrument Panel
Artificial Horizon 52D66	(1) Instrument Panel
Directional Gyro 52D54	(1) Instrument Panel
Roll Servo * 1D363-191R 1C481-229R	(3) In left wing, just outboard of flap
Main cable harness 30C198	
Radio Coupler (Opt.) 1C388	(1) Instrument Panel
Stabilizer Gyro-Amplifier (Opt.) 1C359	(9) Aft of baggage compartment at top left side
Stabilizer Harness 30B184	
Switch 30A204	Pilot's control wheel (Stabilizer install.)
Switch Box 1B405	(10) *(1) At instrument panel with ext. cable to roll servo.
NOTE: * 1D363-191R Roll Servo used in earlier installations. *(1) Field installation optional. Either behind instrument panel with 252 inch extension cable to roll servo, or at roll servo.	

SERVICING DATA

Roll Servo Clutch Setting (lbs): 50± 5

Pitch Servo Clutch Setting (lbs):

Pitch Trim Servo Clutch Setting (lbs):

Trim Sensor Point Gap (in.):

Bridle Cable(s): Roll - 30B218

Limitations Placard Part Number: 13A344-191

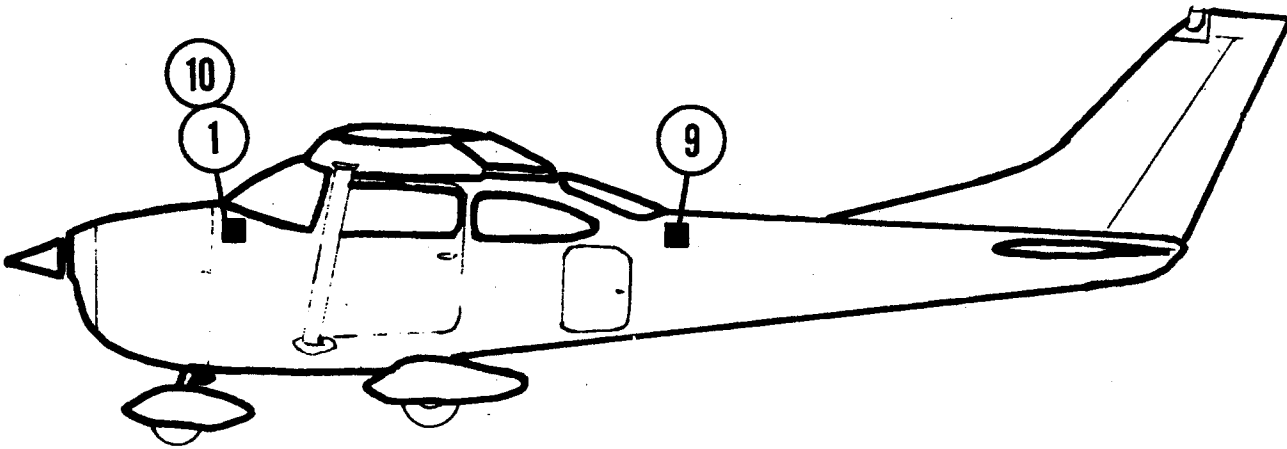
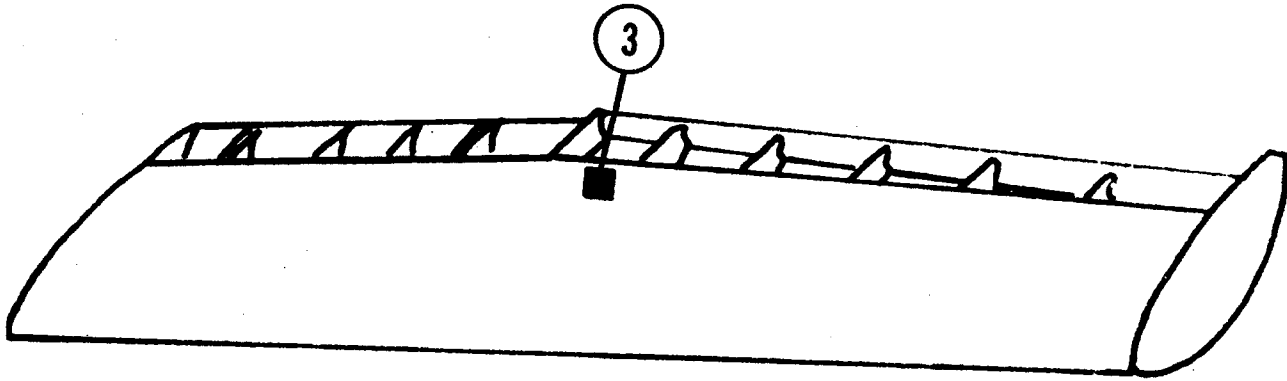

AK241

CESSNA

182, 182A, 182B, 182C, 182D

CENTURY II

AK241
STC SA795SW

CESSNA 182, 182A, 182B,
182C, and 182D

PART DESCRIPTION AND NOMENCLATURE	LOCATION
CONSOLE-AMPLIFIER 1C385	(1) Instrument panel
ARTIFICIAL HORIZON 52D66	(1) Instrument panel
DIRECTIONAL GYRO 52D54	(1) Instrument panel
ROLL SERVO 1C481-229R	(3) Left wing just outboard of flap, aft of rear spar
MAIN CABLE HARNESS 30C198	
RADIO COUPLER (OPT.) 1C388	(1) Instrument panel
STABILIZER (OPT.) 1C359	(9) Just aft of the baggage compartment and the aft fuselage C/L at top
SWITCH BOX 1B405	(10) Used with Stabilizer Option only. On pilot's side of A/C between instrument panel and firewall above aileron cable

SERVICING DATA

Roll Servo Clutch Setting (lbs): 50 ± 5

Pitch Servo Clutch Setting (lbs):

Pitch Trim Servo Clutch Setting (lbs):

Trim Sensor Point Gap (in.):

Bridle Cable(s): Roll - 30B218

Limitations Placard Part Number: 13A344-241

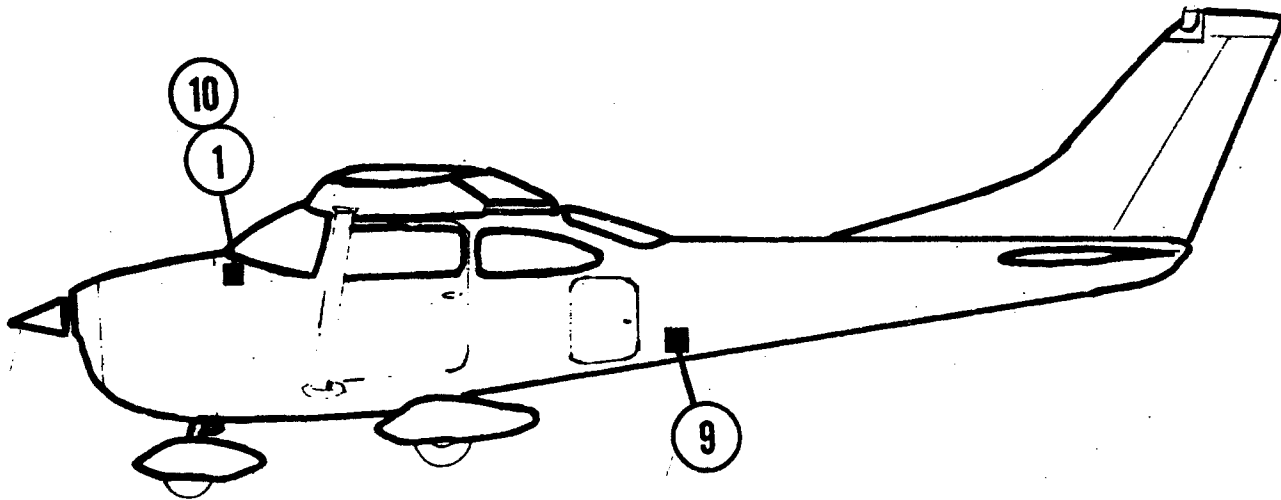
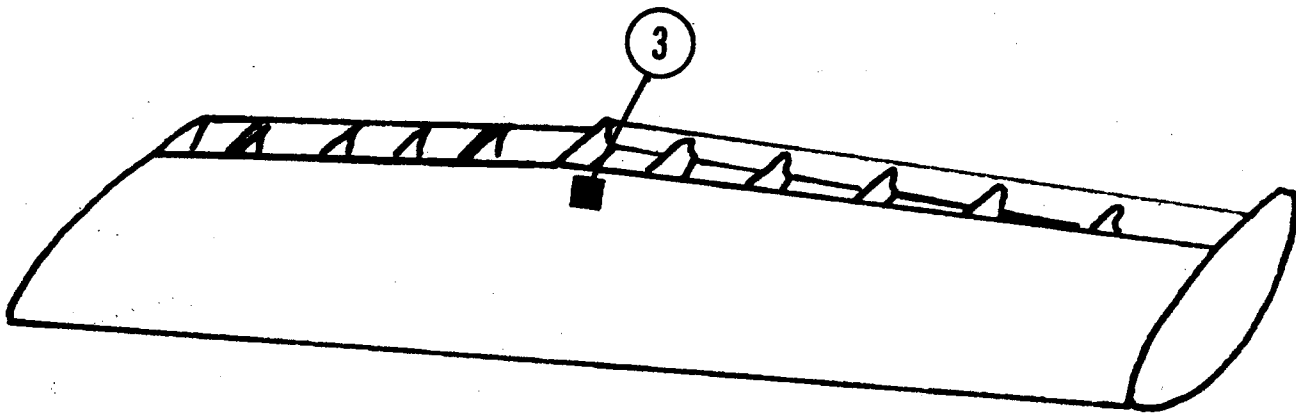

AK199

CESSNA

182E, 182F, 182H, 182J, 182K, 182L,
182M, 182N

CENTURY III

AK197
STC SA624SW

CESSNA 182H, 182J, 182K,
182L, 182M AND 182N

PART DESCRIPTION AND NOMENCLATURE	LOCATION
CONSOLE 1C404	(1) Lower portion of radio cut out
ARTIFICIAL HORIZON 52D67	(1) Instrument panel
DIRECTIONAL GYRO 52D54	(1) Instrument panel
ROLL SERVO 1C363-1-197R	(3) Left wing just outboard of flap and just aft of rear spar
PITCH SERVO 1C363-1-197P	(4) Under floor just aft of aft door post, pilot's side
ALTITUDE HOLD 1C407	(6) Behind instrument panel on rudder tab support, co-pilot's side
MAIN CABLE HARNESS 30D207-2	
RELAY BOX 1A526	(5) Under instrument panel
GYRO-AMPLIFIER 1C359	(9) Just aft of partition between baggage compartment and aft fuselage, left side
RADIO COUPLER 1C388	(1) Instrument panel
TRIM SERVO 1C373-1-197	(7) Aft of partition between baggage compartment and aft fuselage, left side
TRIM SENSOR 1C365-197	(8) In aft fuselage just aft of radion rack, on centerline of A/C
AMPLIFIER 1D395	(2) On aircraft radio rack across aft section of fuselage
TRIM SWITCH 30B192	182 "L" only, pilot's control wheel
TRIM SWITCH 30A364	Pilot's control wheel
SWITCH BOX 1B405	(10) On dust cover, pilot's side, between instrument panel and firewall

SERVICING DATA

Roll Servo Clutch Setting (lbs): 50 ± 5
 Pitch Servo Clutch Setting (lbs): 35 ± 3
 Pitch Trim Servo Clutch Setting (lbs): 25 ± 5
 Trim Sensor Point Gap (in.): $.010 \pm .002$
 Bridle Cable(s): Roll - 30B238-1 Pitch - 30B242
 Limitations Placard Part Number: 13A329-197

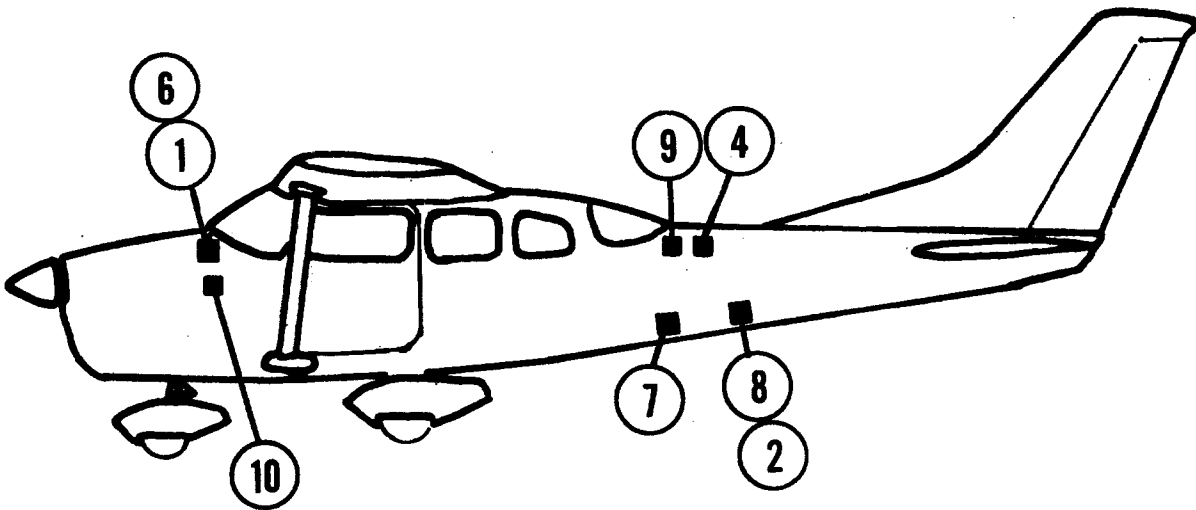
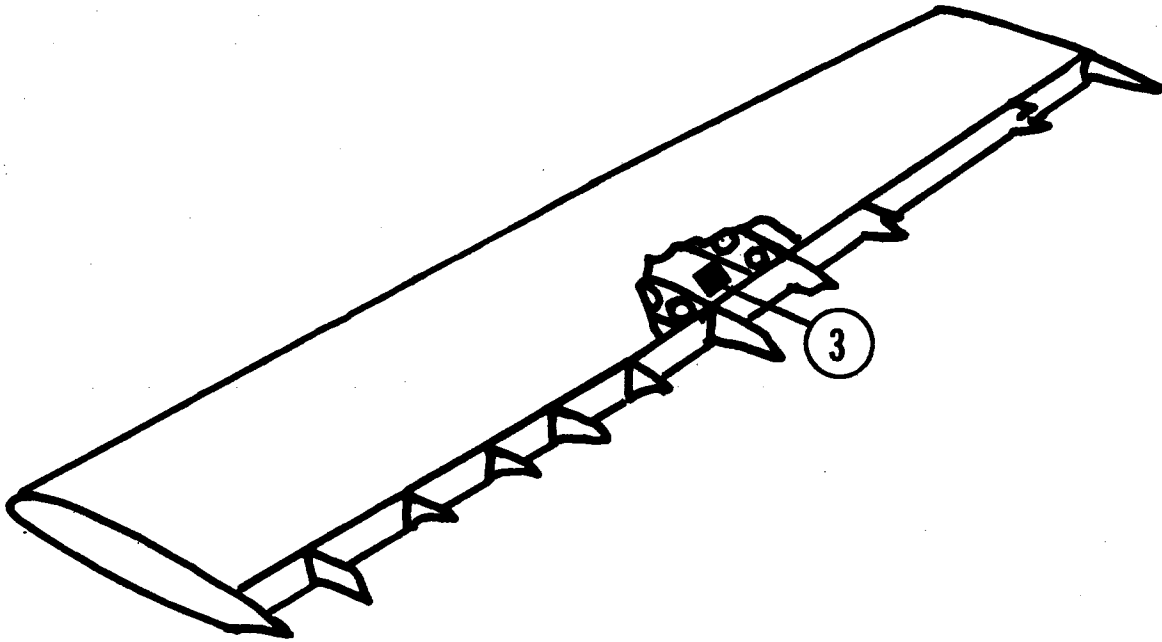

AK218

CESSNA STATIONAIR

206, P206, P206A, P206B, U206, U206A,
U206B, TU206A, TU206B, TP206A, TP206B

CENTURY II

AK199
STC SA658SW.

CESSNA 182E, 182F, 182G, 182H, 182J
182K, 182L, 182M, and 182N

PART DESCRIPTION AND NOMENCLATURE	LOCATION
Console-Amplifier 1C385	(1) Pilot's reach, instrument panel
Artificial Horizon 52D66	(1) Instrument panel
Directional Gyro 52D54	(1) Instrument panel
Roll Servo 1C363-1-191R	(3) Left Wing just outboard of flap, just aft of rear spar
Main cable harness 30C198	
Radio Coupler (Opt.) 1C388	(1) Instrument panel
* Stabilizer (Opt.) 1C359	(9) Aft of partition between the baggage compartment and aft fuselage, left side
Switch Box 1B405	(10) Pilot's side, between instrument panel and firewall, above aileron cable
NOTES: *Stabilizer Kit No. AK204 STC No. SA789SW	

SERVICING DATA

Roll Servo Clutch Setting (lbs): 50 ± 5
 Pitch Servo Clutch Setting (lbs):
 Pitch Trim Servo Clutch Setting (lbs):
 Trim Sensor Point Gap (in.):
 Bridle Cable(s): Roll - 30B238-1
 Limitations Placard Part Number: 13A344-199

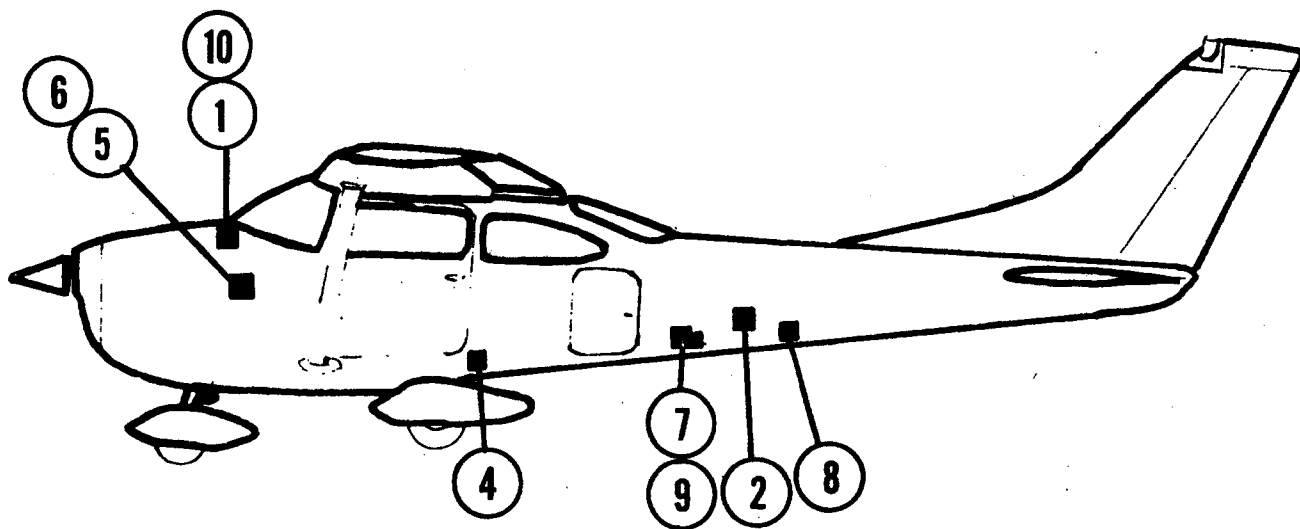
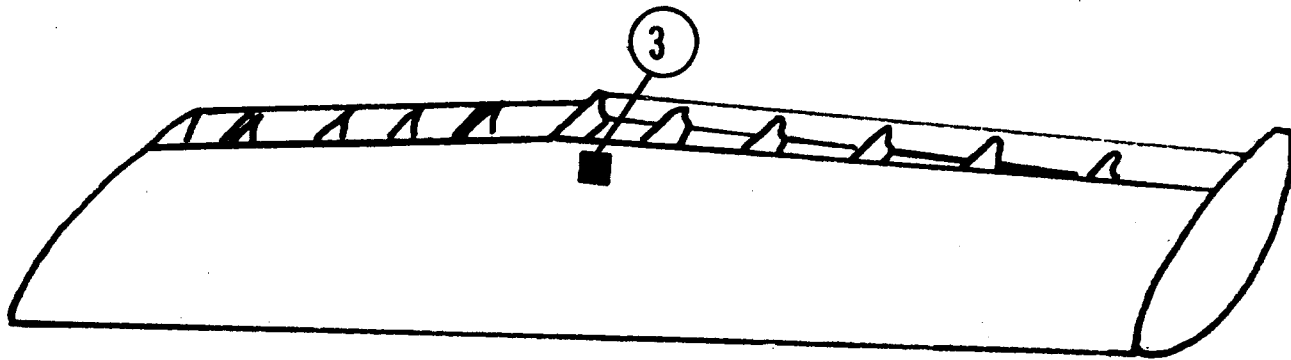

AK197

CESSNA

182H, 182J, 182K, 182L, 182M, 182N

CENTURY III

AK218
STC SA669SW

CESSNA 206, P206, P206A, TP206A,
TU206A, U206, U206A, P206B, TP206B,
TU206B, U206B

PART DESCRIPTION AND NOMENCLATURE	LOCATION
<p>CONSOLE 1C404</p> <p>ARTIFICIAL HORIZON 52D67</p> <p>DIRECTIONAL GYRO 52D54</p> <p>ROLL SERVO 1C363-1-218R</p> <p>PITCH SERVO 1C363-1-218P</p> <p>ALTITUDE HOLD 1C407</p> <p>MAIN CABLE HARNESS 30D207-2</p> <p>GYRO-AMPLIFIER 1C359</p> <p>RADIO COUPLER 1C388</p> <p>TRIM SERVO 1C373-1-218</p> <p>TRIM SENSOR 1C365-218</p> <p>AMPLIFIER 1D395</p> <p>SWITCH BOX 1B405</p>	<p>(1) Lower portion of radio cut out area</p> <p>(1) Instrument panel</p> <p>(1) Instrument panel</p> <p>(3) In right wing just outboard of wing rib at wing Station 118.00, forward of rear spar</p> <p>(4) Aft of partition between Baggage compartment and aft fuselage, on forward side fuselage Station 152.2, right side</p> <p>(6) On the top instrument panel inspection plate, right side</p> <p>(9) Mounted to aft side of baggage compartment partition top left side</p> <p>(1) Instrument panel</p> <p>(7) Under baggage compartment floor, aft on A/C centerline</p> <p>(8) Aft fuselage, second bay aft of baggage compartment partition (near fuselage Station 166.40) on aircraft C/L, low</p> <p>(2) On aircraft radio rack in aft section, aft of baggage compartment</p> <p>(10) On bulkhead, co-pilot's side between instrument panel and firewall</p>

SERVICING DATA

Roll Servo Clutch Setting (lbs): 40 ± 5
 Pitch Servo Clutch Setting (lbs): 28 ± 3
 Pitch Trim Servo Clutch Setting (lbs): 25 ± 5
 Trim Sensor Point Gap (in.): $.010 \pm .002$
 Bridle Cable(s): Roll - 30B244-1 Pitch - 30B261
 Limitations Placard Part Number: 13A329-218

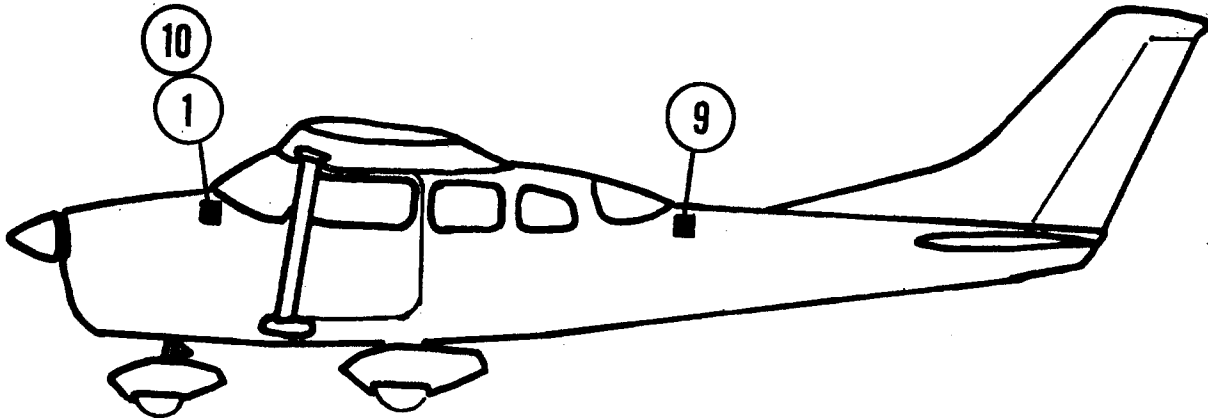
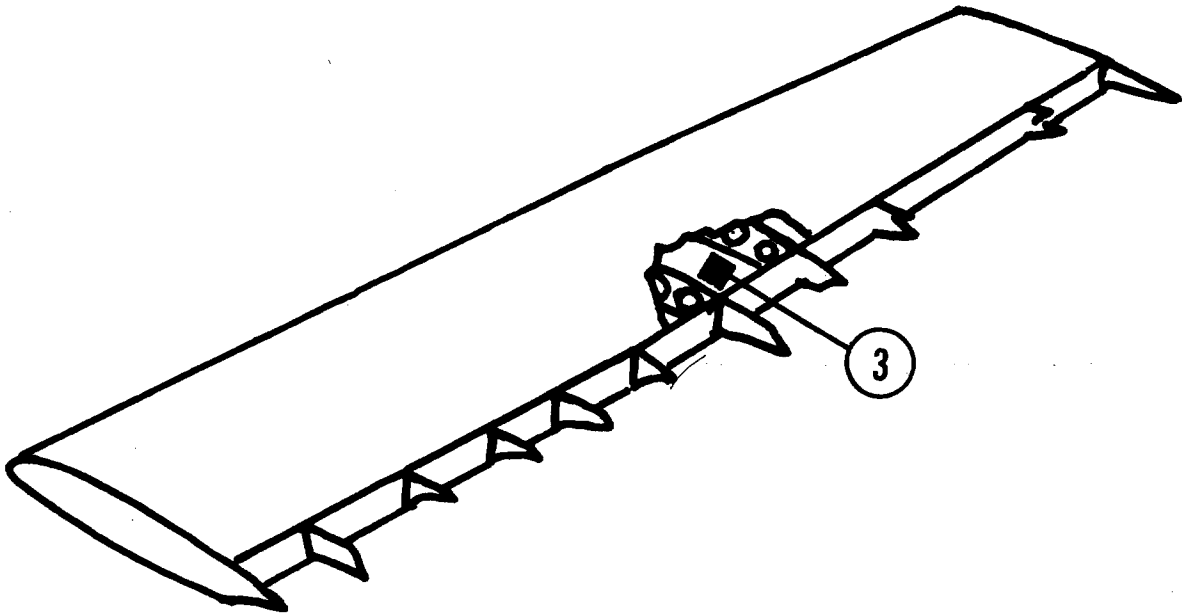

AK231

CESSNA

206, P206, P206A, P206B, U206, U206A,
U206B, TU206A, TU206B, TP206A, TP206B

CENTURY II

AK231
STC SA727SA

CESSNA 206, P206, P206A, P206B, U206,
U206A, U206B, TU206A, TU206B, TP206A
and TP206B

PART DESCRIPTION AND NOMENCLATURE	LOCATION
Console-Amplifier 1C385	(1) Instrument panel
Artificial Horizon 52D66	(1) Instrument Panel
Directional Gyro 52D54	(1) Instrument Panel
Roll Servo 1C363-1-209R	(3) In right wing, just outboard of wing rib at Station 118.00
Main Cable Harness 30C198	
Radio Coupler 1C388	(1) Instrument panel
Gyro-Amplifier 1C359	(9) Top of bulkhead at aft portion of baggage area.
Switch Box 1B405	(10) On bulkhead, co-pilot's side between instrument panel and firewall.
Trim Switch 30A204	Pilot's control wheel

SERVICING DATA

Roll Servo Clutch Setting (lbs): 40 ± 5

Pitch Servo Clutch Setting (lbs):

Pitch Trim Servo Clutch Setting (lbs):

Trim Sensor Point Gap (in.):

Bridle Cable(s): Roll - 30B244

Limitations Placard Part Number: 13A344-231

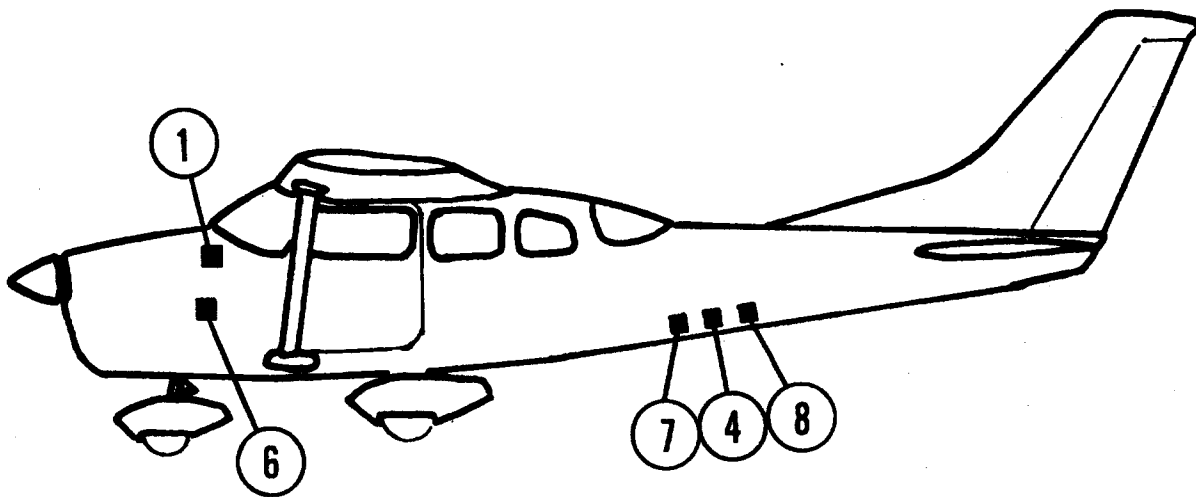
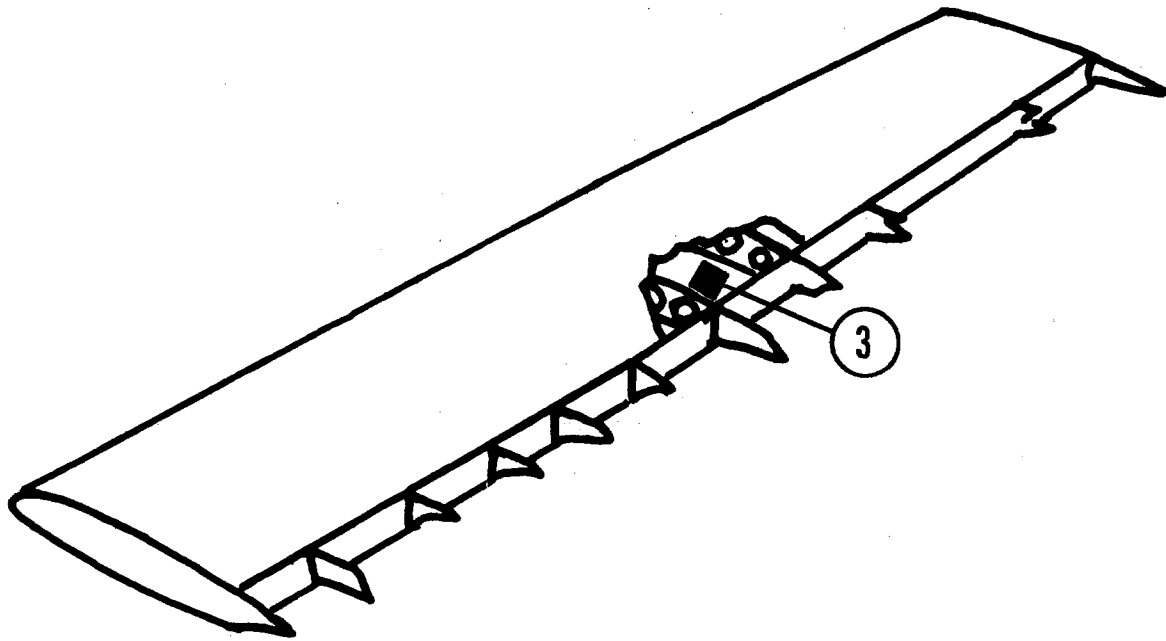

AK368

CESSNA

P206C, P206D, P206E, U206C, U206D,
U206E

CENTURY III

AK368
STC SA1431SW

CESSNA P206C, P206D, P206E, U206C,
U206D, AND U206E

PART DESCRIPTION AND NOMENCLATURE	LOCATION
CONSOLE 1C404	(1) Instrument panel
ARTIFICIAL HORIZON 52D67	(1) Instrument panel
DIRECTIONAL GYRO 52D67	(1) Instrument panel
ROLL SERVO 1C363-1-357R	(3) In right wing outboard of wing rib Station 118.00 forward of rear spar
PITCH SERVO 1C508-1-368P	(4) Aft of baggage compartment partition and aft fuselage, forward Station 152.2 right side of C/L
ALTITUDE HOLD 1C407	(6) Under instrument panel next to firewall, above pilot's rudder pedals
MAIN CABLE HARNESS 30D207-2	(5) Should be located between instrument panel and forward cabin bulkhead
RELAY BOX 1A526	(1) Instrument panel
RADIO COUPLER 1C388-M or 1C388-MC	(1) Behind instrument panel within 3 feet of artificial horizon
GLIDE SLOPE COUPLER 1C493	(7) Aft of baggage compartment on pilot's side. Remove aft baggage compartment
GLIDE SLOPE COUPLER HAR- NESS 30C291	(8) Aft fuselage, second bay aft of baggage compartment partition on C/L
TRIM SERVO 1C373-1-368	Pilot's control wheel
TRIM SENSOR 1C365-218	(2) Under baggage compartment floor, co-pilot's side
TRIM SWITCH 30A364	
AMPLIFIER 1C515-1	

SERVICING DATA

Roll Servo Clutch Setting (lbs): $38 \begin{smallmatrix} +7 \\ -8 \end{smallmatrix}$
 Pitch Servo Clutch Setting (lbs): $24 \begin{smallmatrix} +3 \\ -4 \end{smallmatrix}$
 Pitch Trim Servo Clutch Setting (lbs): 25 ± 2
 Trim Sensor Point Gap (in.): $.010 \pm .002$

Bridle Cable(s): Pitch - 30B261 Roll - 30B244-2
 Limitations Placard Part Number: 13A682=368 30B244-3

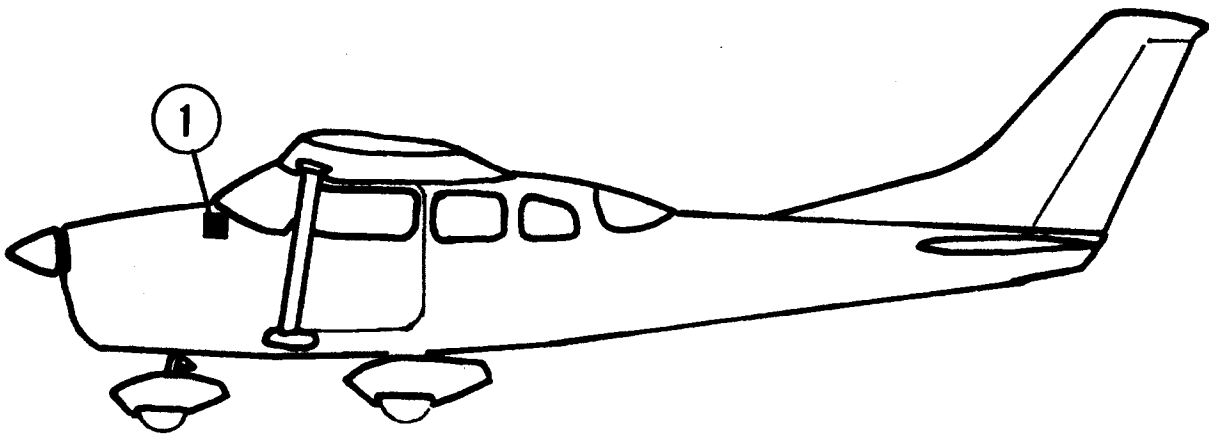
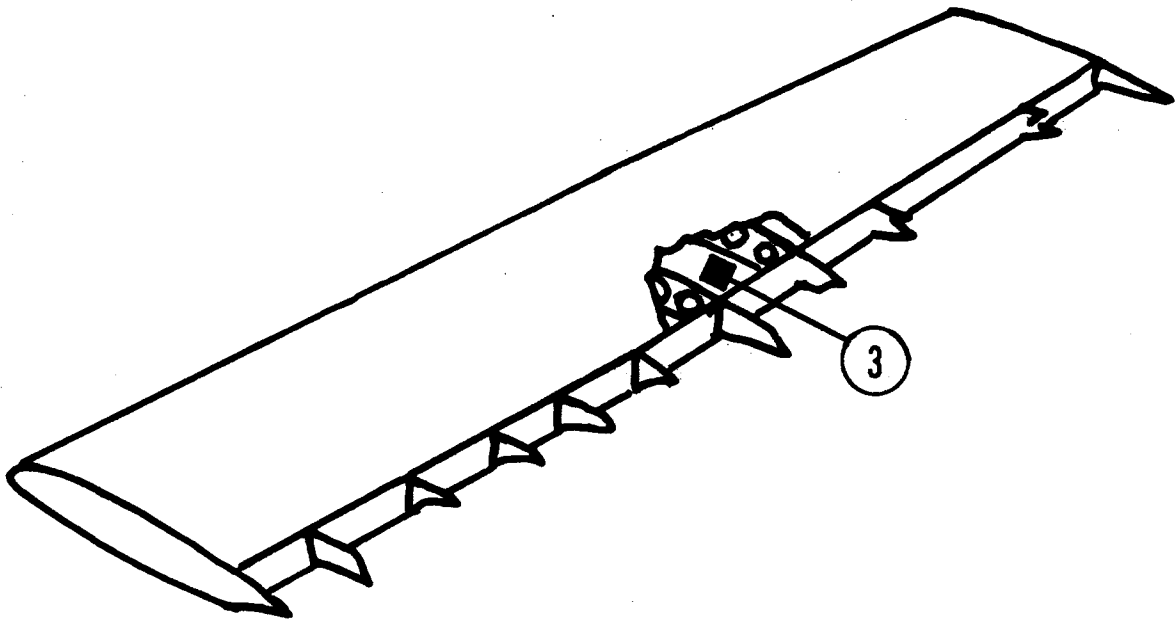

AK369

CESSNA

P206C, P206D, P206E, U206C, U206D, U206E

CENTURY II

AK369
STC SA1449SW

CESSNA U206C, U206D, U206E, P206C,
P206D AND P206E

PART DESCRIPTION AND NOMENCLATURE	LOCATION
CONSOLE-AMPLIFIER 1C385	(1) In Radio Panel
ROLL SIGNAL FILTER 1B440	(1) Under instrument panel near artificial horizon
ARTIFICIAL HORIZON 52D66	(1) Instrument panel
DIRECTIONAL GYRO 52D54	(1) Instrument panel
ROLL SERVO 1C363-1-357R	(3) In right wing just outboard of wing rib at Station 118.00, forward of rear spar
MAIN CABLE HARNESS 30C198	
RADIO COUPLER 1C388	(1) Instrument panel

SERVICING DATA

Roll Servo Clutch Setting (lbs): 38 ⁺⁷
-8
Pitch Servo Clutch Setting (lbs):
Pitch Trim Servo Clutch Setting (lbs):
Trim Sensor Point Gap (in.):
Bridle Cable(s): Roll - 30B244-2, 30B244-3
Limitations Placard Part Number: 13A344-369

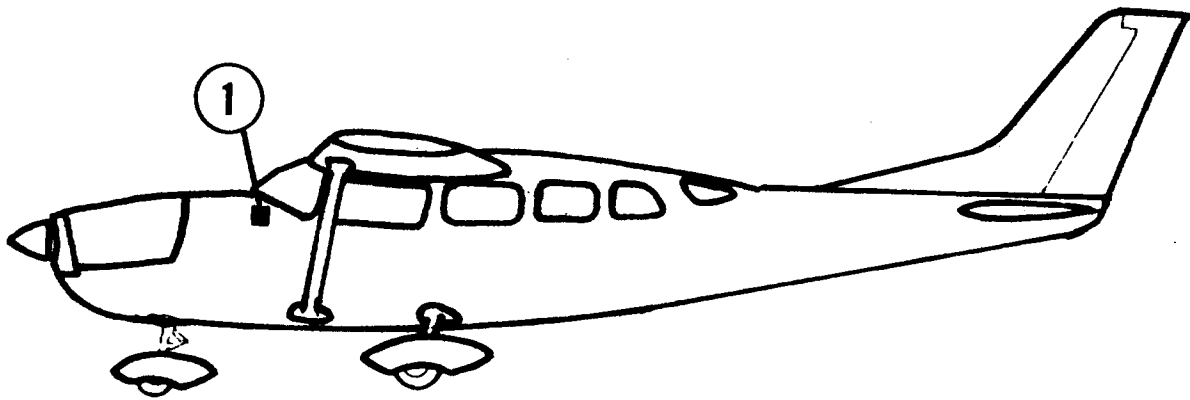
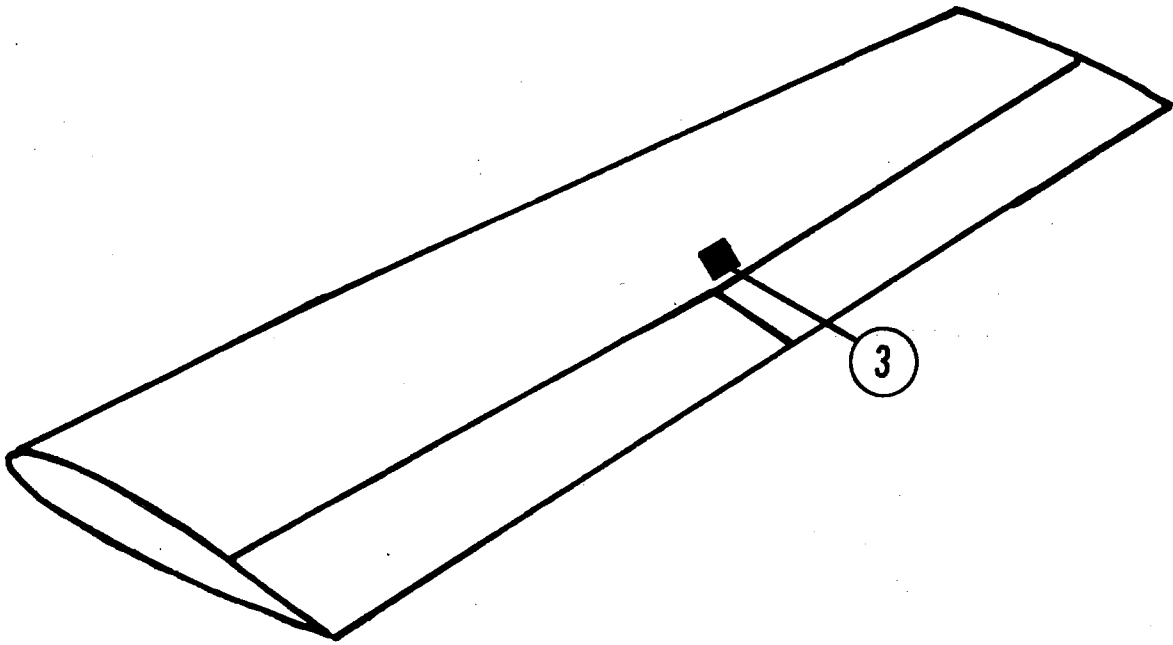

AK357

CESSNA SKYWAGON

207

CENTURY II

AK357
STC SA1402SW

CESSNA 207

PART DESCRIPTION AND NOMENCLATURE	LOCATION
CONSOLE-AMPLIFIER 1C385	(1) Instrument panel
ARTIFICIAL HORIZON 52D66	(1) Instrument panel
DIRECTIONAL GYRO 52D54	(1) Instrument panel
ROLL SERVO 1C363-1-357R	(3) Right wing, outboard of rib at Station 118; forward of rear spar
MAIN CABLE HARNESS 30C198	
RADIO COUPLER Standard - 1C388-M Collins or King - 1C388-MC	(1) Instrument panel
NOTES: Command Electric Trim AK361 – STC SA1404SW	

SERVICING DATA

Roll Servo Clutch Setting (lbs): 38 ⁺⁷ -8
 Pitch Servo Clutch Setting (lbs):
 Pitch Trim Servo Clutch Setting (lbs):
 Trim Sensor Point Gap (in.):
 Bridle Cable(s): Roll - 30B244-2
 Limitations Placard Part Number: 13A344-357

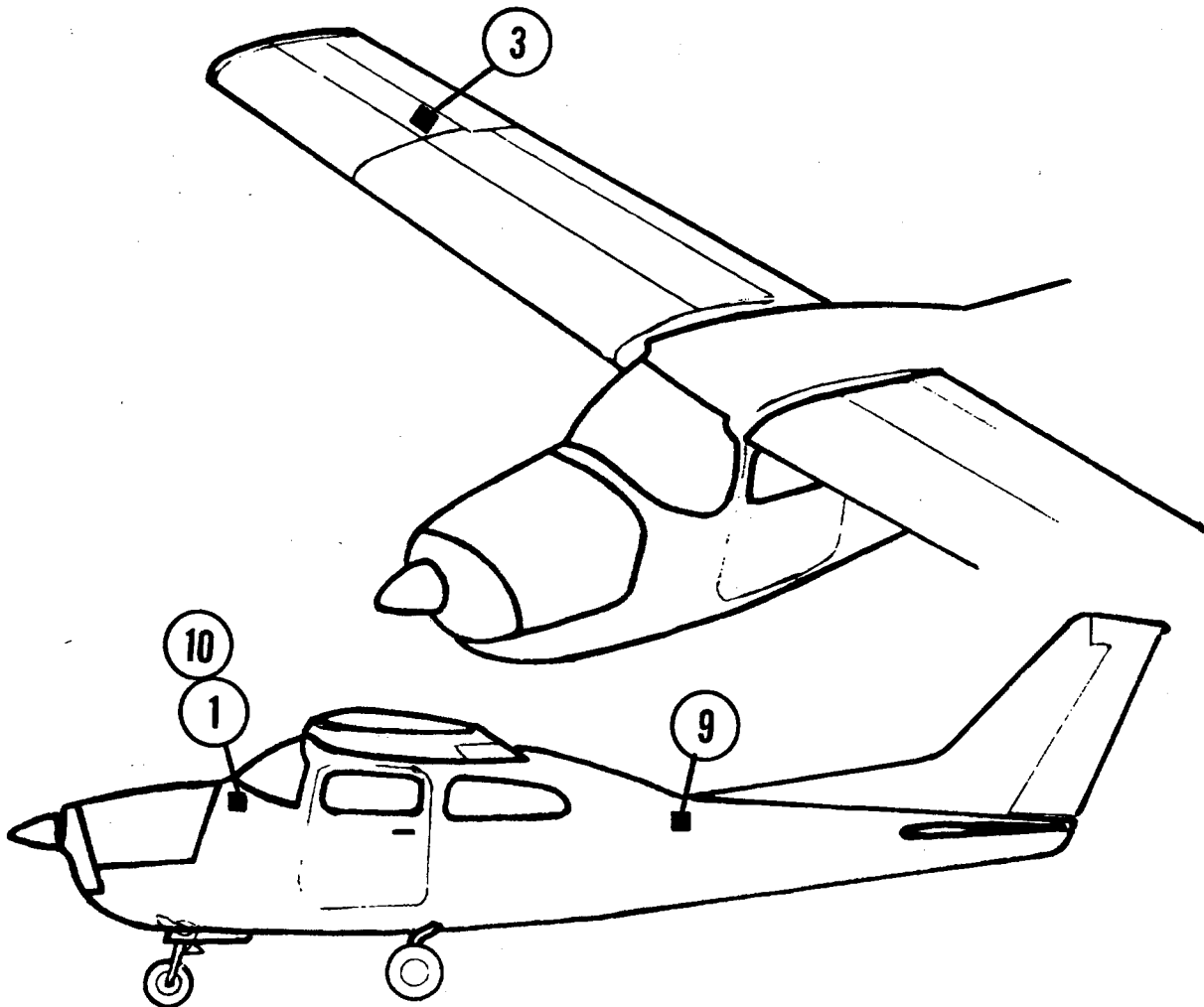

AK212

CESSNA CENTURION

210D, 210E, 210F, T210F

CENTURY II

AK212
STC SA675SW

CESSNA 210D, 210E, 210F
AND T210F

PART DESCRIPTION AND NOMENCLATURE	LOCATION
Console-Amplifier 1C385	(1) Instrument panel
Artificial Horizon 52D66	(1) Instrument panel
Directional Gyro 52D54	(1) Instrument panel
Roll Servo 1D363-209R	(3) Forward of right rear spar, outboard of rib at Station No. 124.00. Just inboard of aileron area.
Main Cable Harness 30C198	
Radio Coupler (Opt.) 1C388	(1) Instrument panel
Stabilizer Gyro-Amplifier 1C359	(9) Aft side of baggage compartment bulkhead, top left.
Switch Box 1B405	(10) On bulkhead between instrument panel and firewall, pilot's side.

SERVICING DATA

Roll Servo Clutch Setting (lbs): 40 ± 5

Pitch Servo Clutch Setting (lbs):

Pitch Trim Servo Clutch Setting (lbs):

Trim Sensor Point Gap (in.):

Bridle Cable(s): Roll - 30B244-1

Limitations Placard Part Number: 13A344-212

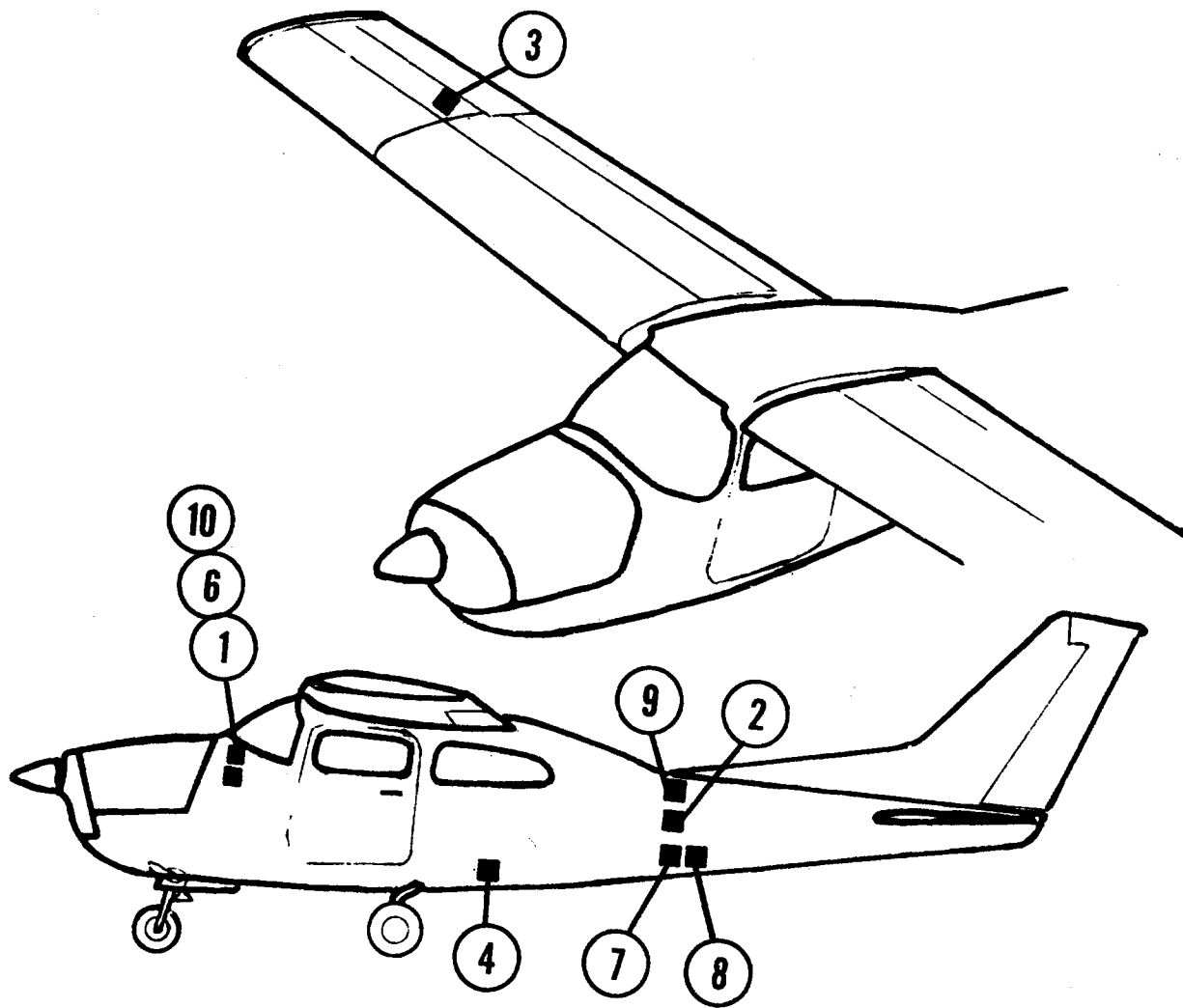

AK209

CESSNA

T210, 210F

CENTURY III

AK209
STC SA637SW

CESSNA T210F AND 210F

PART DESCRIPTION AND NOMENCLATURE	LOCATION
CONSOLE 1C404	(1) Instrument panel
ARTIFICIAL HORIZON 52D67	(1) Instrument panel
DIRECTIONAL GYRO 52D54	(1) Right instrument panel
ROLL SERVO 1D363-209R	(3) Forward of rear spar, outboard of rib station 124.00, just outboard of aileron area
PITCH SERVO 1D363-209P	(4) Under floorboard, second bay aft of door, co-pilot's side (behind seats)
ALTITUDE HOLD 1C407	(6) Top instrument panel inspection plate, right side of C/L of A/C
MAIN CABLE HARNESS 30D207-2	
GYRO-AMPLIFIER 1C359	(9) Aft side of baggage compartment bulkhead, top left
RADIO COUPLER 1C388	(1) Instrument panel
TRIM SERVO 1D363-170	(7) Just aft of baggage compartment floor, center of A/C
TRIM SENSOR 1C318-209	(8) Behind rear seats where cables go up from the floor, center of A/C
TRIM SWITCH 30B192	Pilot's control wheel
AMPLIFIER 1D395	(2) On aircraft radio rack, aft section, just behind aft baggage compartment partition, left or right side
SWITCH BOX 1B405	(10) On bulkhead on left side of aircraft between instrument panel and firewall

SERVICING DATA

Roll Servo Clutch Setting (lbs): 40 ± 5
 Pitch Servo Clutch Setting (lbs): 24 ± 2
 Pitch Trim Servo Clutch Setting (lbs): 25 ± 5
 Trim Sensor Point Gap (in.): $.010 \pm .002$
 Bridle Cable(s): Roll - 30B293 Pitch - 30B243
 Limitations Placard Part Number: 13A329-209

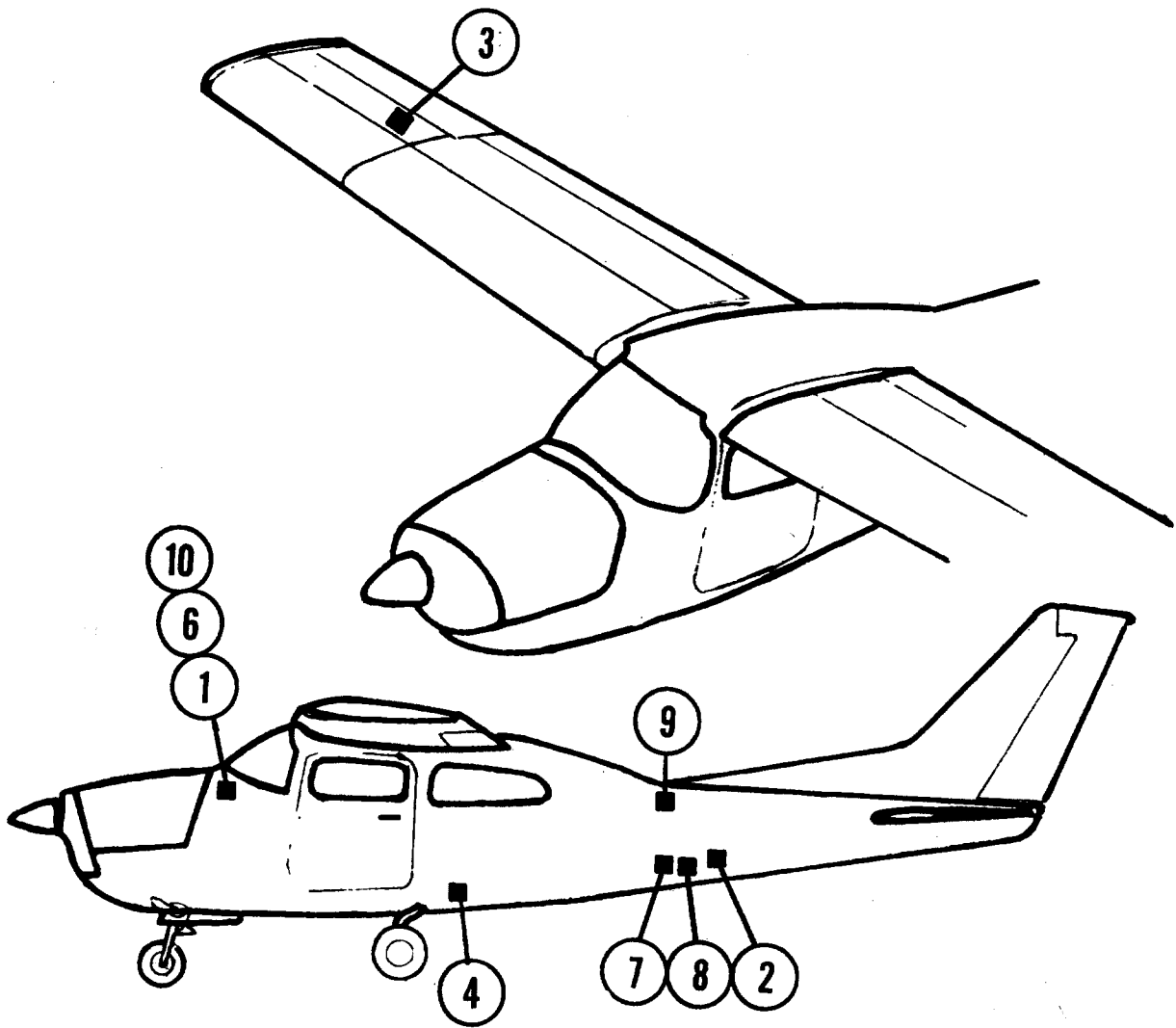

AK254

CESSNA

210G, 210H

CENTURY III

AK254
STC SA829SW

CESSNA 210G, 210H

PART DESCRIPTION AND NOMENCLATURE	LOCATION
CONSOLE 1C404	(1) Instrument panel
ARTIFICIAL HORIZON 52D67	(1) Instrument panel
DIRECTIONAL GYRO 52D54	(1) Instrument panel
ROLL SERVO 1D363-254R	(3) Mounted in right wing on outboard side of rib between Station 148.00 and 172.00, aft of main spar near oblong inspection hole
PITCH SERVO 1D363-209P	(4) Under floor, board, second bay aft of door, copilot's side (behine seat)
ALTITUDE HOLD 1C407	(6) Top instrument panel inspection plate right side of C/L
MAIN CABLE HARNESS 30D207-2	
GYRO -AMPLIFIER 1C359	(9) Mounted to aft side of baggage compartment, bulkhead top left
RADIO COUPLER 1C388-M	(1) Instrument panel
TRIM SERVO 1D373-170	(7) Just aft of baggage compartment floor, center of A/C
TRIM SENSOR 1C318-209	(8) Behind rear seats where cables go up from the floor, center of A/C
TRIM SWITCH 30B192	Pilot's control wheel
AMPLIFIER 1D395	(2) Aircraft radio rack aft section, just behind aft baggage compartment partition, left or right side
SWITCH BOX 1B405	(10) On bulkhead on co-pilot side between instrument panel and firewall

SERVICING DATA

Roll Servo Clutch Setting (lbs): 45 ± 5
 Pitch Servo Clutch Setting (lbs): 24 ± 2
 Pitch Trim Servo Clutch Setting (lbs): 25 ± 5
 Trim Sensor Point Gap (in.): $.010 \pm .002$

Limitations Placard Part Number: 13A329-254

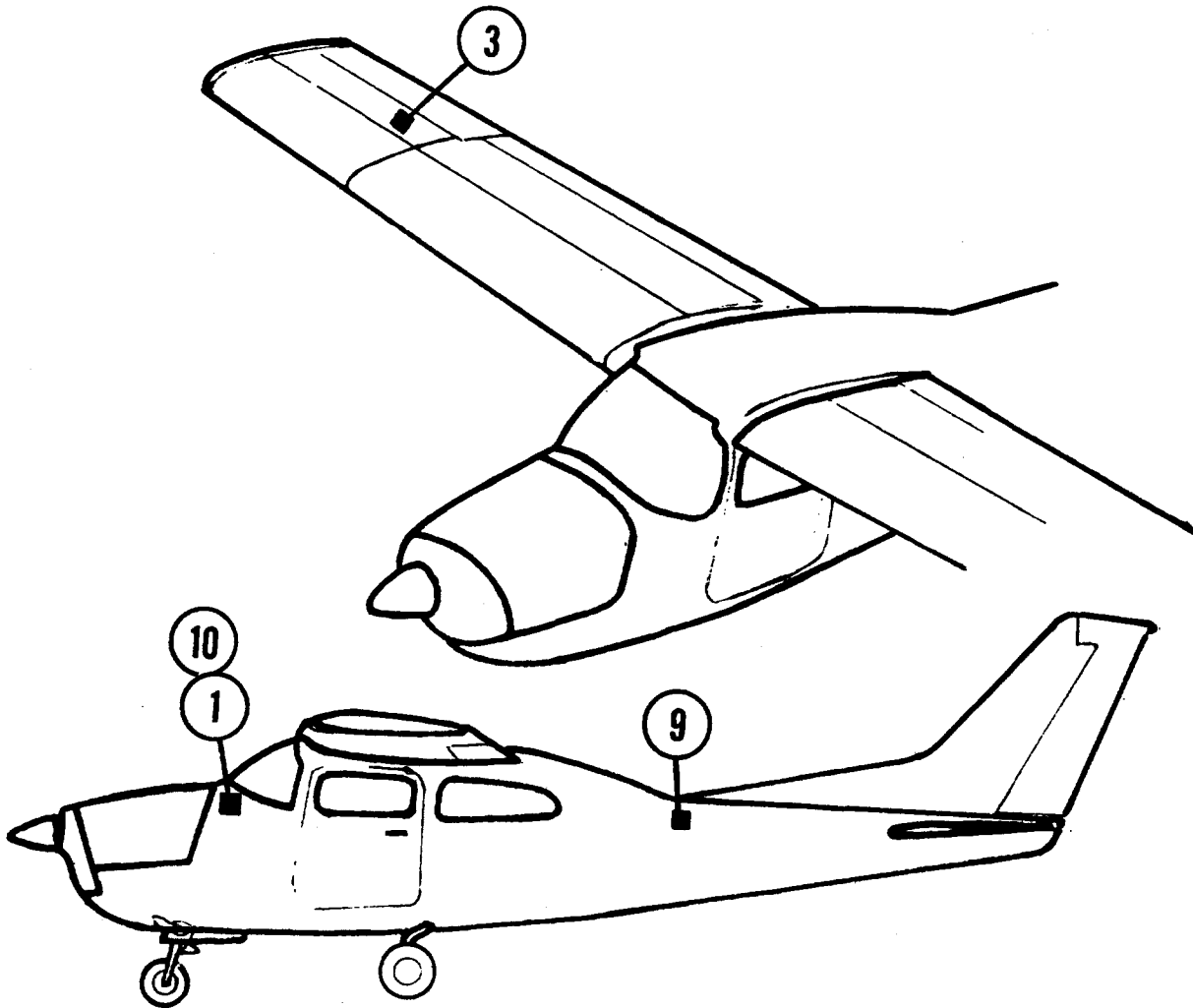

AK258

CESSNA

210G, 210H, T210G

CENTURY II

AK258
STC SA850SW

CESSNA 210G, 210H and T210G

PART DESCRIPTION AND NOMENCLATURE	LOCATION
CONSOLE-AMPLIFIER 1C385	(1) Instrument panel
ARTIFICIAL HORIZON 52D66	(1) Instrument panel
DIRECTIONAL GYRO 52D54	(1) Instrument panel
ROLL SERVO 1D363-254R	(3) Mounted in right wing on outboard side of rib between Station 148.00 and 172.00, aft of main spar near oblong inspection hole
MAIN CABLE HARNESS 30C198	
RADIO COUPLER (OPT.) 1C388-M	(1) Instrument panel
STABILIZER (OPT.) 1C359	(9) Mounted to bulkhead at aft top portion of baggage area, left side
SWITCH BOX 1B405	(10) Used with Stabilizer Option only. On bulkhead on pilot's side of aircraft between instrument panel and firewall.

SERVICING DATA

Roll Servo Clutch Setting (lbs): 45 ± 5
 Pitch Servo Clutch Setting (lbs):
 Pitch Trim Servo Clutch Setting (lbs):
 Trim Sensor Point Gap (in.):
 Bridle Cable(s): Roll - 30B293
 Limitations Placard Part Number: 13A344-258

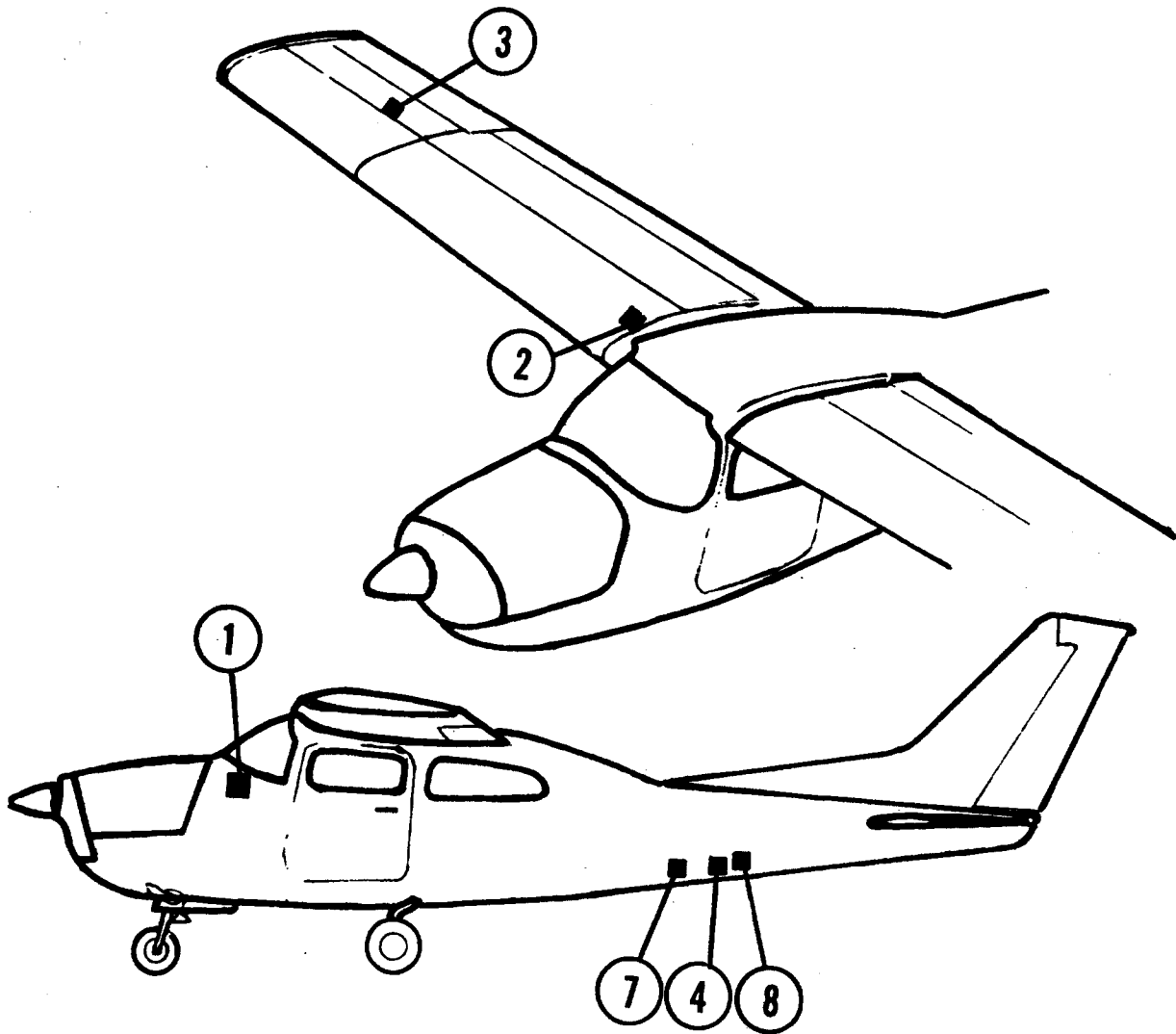

AK331

CESSNA

210K, T210K

CENTURY III

AK 331
STC SA1325SW

CESSNA

210K AND T210K

PART DESCRIPTION AND NOMENCLATURE	LOCATION
CONSOLE 1C404	(1) Lower portion of radio cutout
ARTIFICIAL HORIZON 52D67	(1) Instrument panel
DIRECTIONAL GYRO 52D54	(1) Instrument panel
ROLL SERVO 1C508-1-331R	(3) In right wing outboard of rib Station 155.00
PITCH SERVO 1C508-1-331P	(4) Aft fuselage at Station 180.6 on bottom
ALTITUDE HOLD 1C407	(6) Under instrument panel at firewall above pilot's rudder pedals
MAIN CABLE HARNESS 30D207-14	
RELAY BOX 1A526	(5) Under instrument panel
RADIO COUPLER 1C388	(1) Instrument panel
GLIDE SLOPE COUPLER 1C493	(1) Under instrument panel within 3 feet of artificial horizon
G. S. COUPLER HARNESS 30C291	
TRIM SERVO 1C373-1-331	(7) Aft of baggage compartment approximately 8 inches on bottom
TRIM SENSOR 1C476-331	(8) Aft of baggage compartment between fuselage Station 180.6 and 194.8
TRIM SWITCH 30A364	Pilot's control wheel
AMPLIFIER 1C515-1	(2) In first large inspection hole right wing at Station 25.25

SERVICING DATA

Roll Servo Clutch Setting (lbs): 27 ± 7
 Pitch Servo Clutch Setting (lbs): 30 ± 4
 Pitch Trim Servo Clutch Setting (lbs): 25 ± 2
 Trim Sensor Point Gap (in.): $.014 \pm .002$
 Bridle Cable(s): Roll - 30B293 Pitch - 30B243
 Limitations Placard Part Number: See AFM Supplement

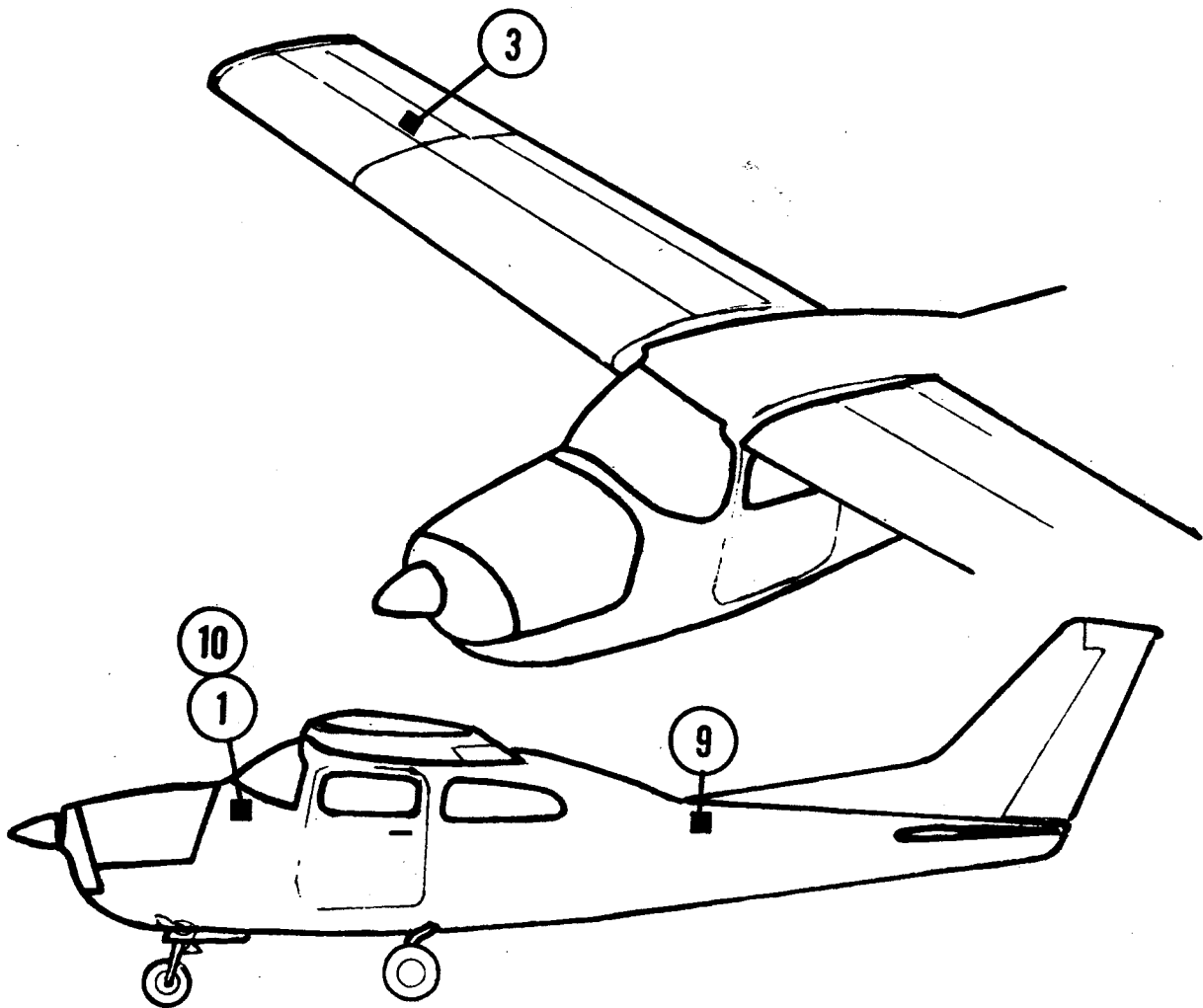

AK334

CESSNA

210J, T210J, 210K, T210K

CENTURY II

AK334
STC SA1326SW

CESSNA
210J, T210J, 210K, T210K

PART DESCRIPTION AND NOMENCLATURE	LOCATION
CONSOLE-AMPLIFIER 1C385	(1) Instrument panel
ARTIFICIAL HORIZON 52D66	(1) Instrument panel
DIRECTIONAL GYRO 52D54	(1) Instrument panel
ROLL SERVO 1C508-1-331R	(3) Mounted to rib by oblong inspection hole in right wing at Station 155.00, forward rear spar.
MAIN CABLE HARNESS 30C198	
RADIO COUPLER (OPT.) 1C388	(1) Instrument panel
STABILIZER SWITCH 30A204	Pilot's control wheel
GYRO-AMPLIFIER 1C359	(9) To bulkhead at the aft top portion of baggage area, left side
SWITCH BOX 1B405	(10) On bulkhead, pilot's side, between instrument panel and firewall.

SERVICING DATA

Roll Servo Clutch Setting (lbs): 27 ± 7
 Pitch Servo Clutch Setting (lbs):
 Pitch Trim Servo Clutch Setting (lbs):
 Trim Sensor Point Gap (in.):
 Bridle Cable(s): N/A
 Limitations Placard Part Number: 13A344-334

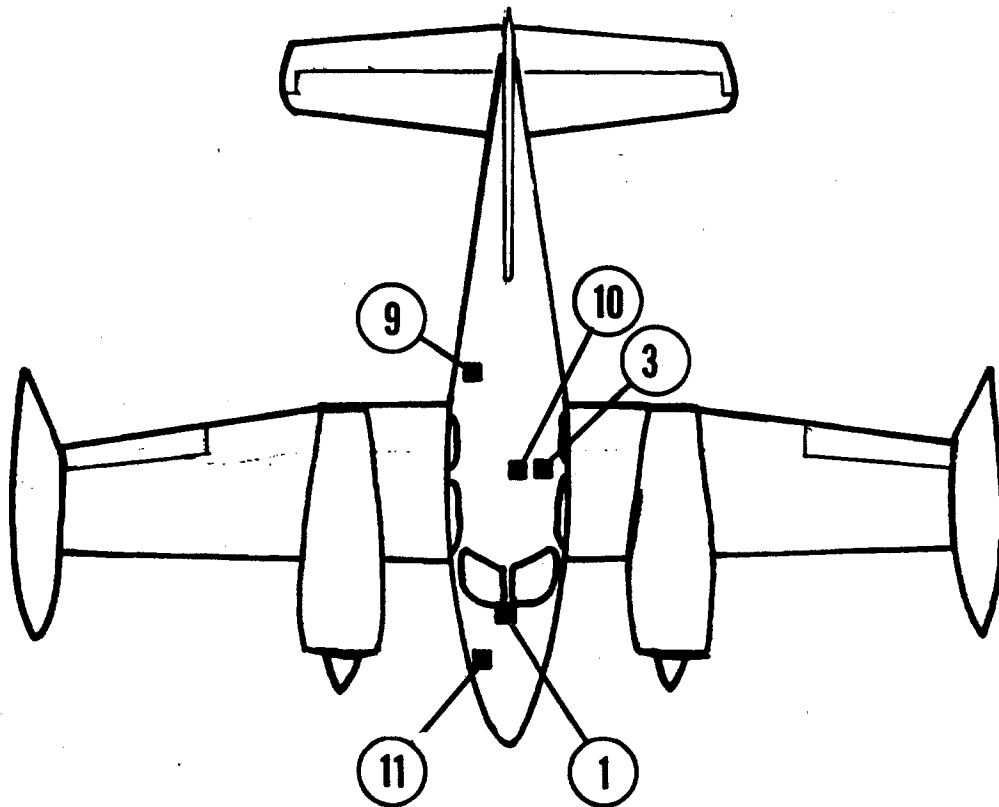
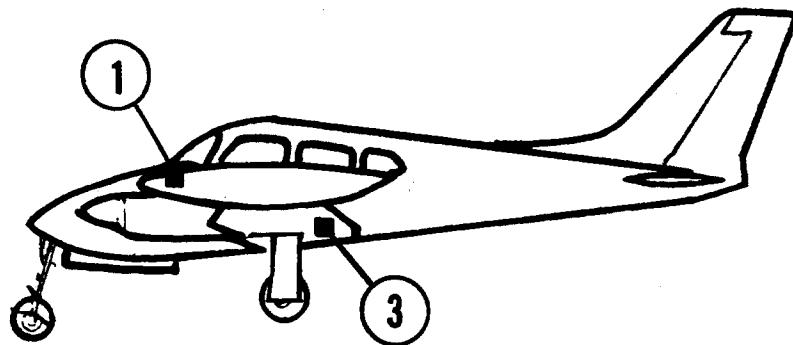

AK201

CESSNA

310D, 310G, 310H, 310I, 310J, 310K, 310L,
310N, 320D, 320E, 320F

CENTURY II

AK201
STC SA737SW

CESSNA: 310D, 310G, 310H, 310I, 310J,
310K, 310L, 310N, 320E and 320F and 320D

PART DESCRIPTION AND NOMENCLATURE	LOCATION
Console-Amplifier 1C385-24	(1) Pedestal
Roll Signal Filter 1B440	(1) Under instrument panel near artificial horizon
Artificial Horizon 52D66	(1) Instrument panel
Directional Gyro 52D54	(1) Instrument panel
Roll Servo 1D414-198R	(3) Under floor just forward of rear spar, pilot's side
Main Cable Harness 30C198	
Radio Coupler (Opt.) 1C388	(1) Instrument Panel
Stabilizer Gyro-Amplifier (Opt.) 1C359	(9) Aft of baggage compartment aft partition, on floor, co-pilot's side
Switch Box 1B405-24	(10) Under floor just forward of rear spar, pilot's side
Inverter 48C17	(11) On radio rack in nose section, center line of A/C to right side

SERVICING DATA

Roll Servo Clutch Setting (lbs): 45 ± 5
 Pitch Servo Clutch Setting (lbs):
 Pitch Trim Servo Clutch Setting (lbs):
 Trim Sensor Point Gap (in.):
 Bridle Cable(s): Roll - 30B221
 Limitations Placard Part Number: 13A344-201

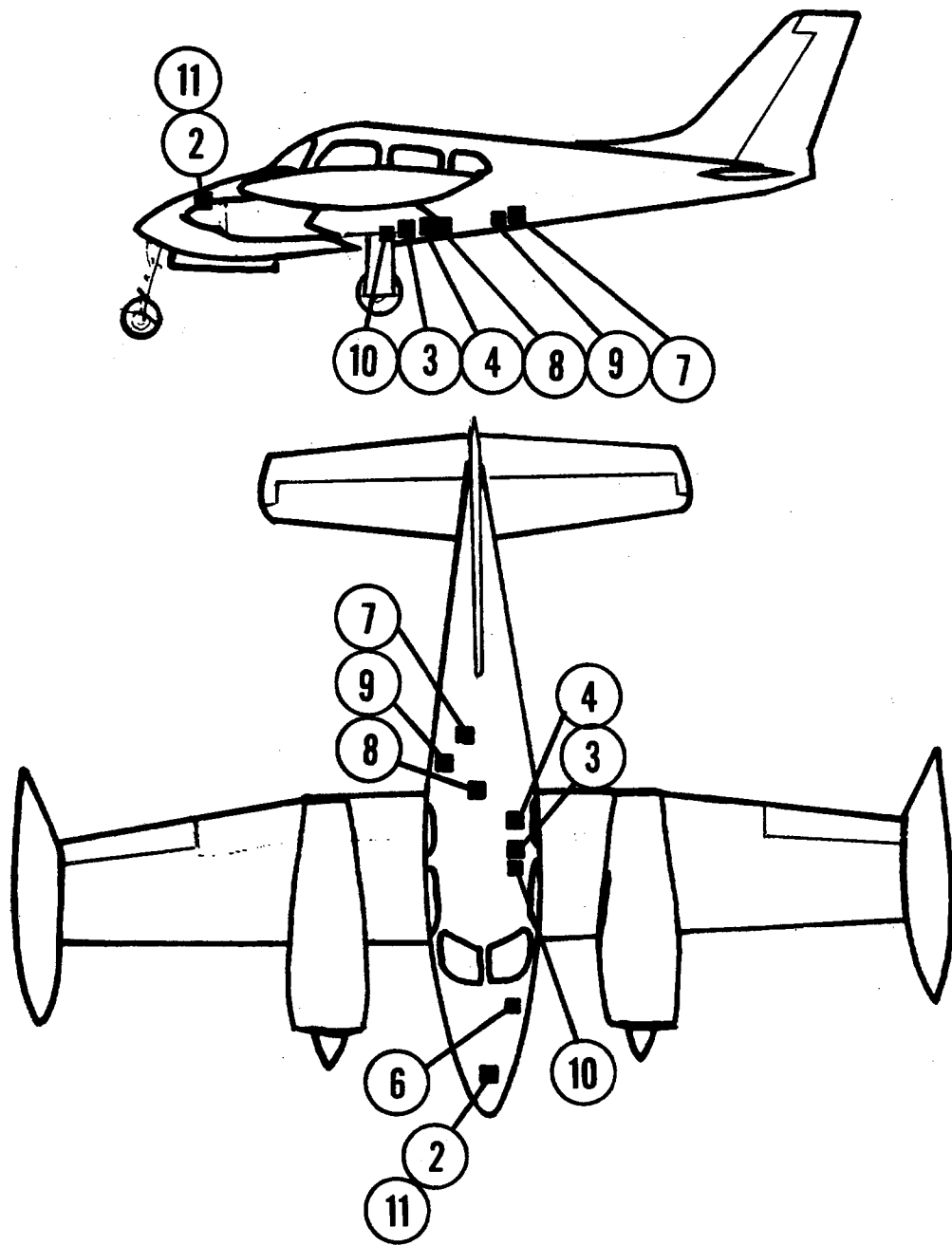

AK222

CESSNA

310D, 310G, 310H, 310I, 310J, 320D

CENTURY III

AK222
STC SA 667SW

CESSNA 310D, 310G, 310H,
310J, 310I, 320D

PART DESCRIPTION AND NOMENCLATURE	LOCATION
CONSOLE 1C404	(1) On pedestal beneath throttle controls
ARTIFICIAL HORIZON 52D67	(1) Instrument panel
DIRECTIONAL GYRO 52D54	(1) Instrument panel
ROLL SERVO 1C465-1-222R	(3) Under aircraft floorboard, just forward of rear wing spar, pilot's side
PITCH SERVO 1C470-1-222P	(4) Under aircraft floorboard, just aft of rear wing spar, pilot's side
ALTITUDE HOLD 1C407	(6) Angle brace, under instrument panel, pilot's side
MAIN CABLE HARNESS 30D207-4	
RELAY BOX 1A526-1	
RADIO COUPLER 1C388	(1) Instrument panel
GLIDE SLOPE COUPLER 1C493	(1) Ref. AK262
G.S. COUPLER HARNESS 30C291	
TRIM SERVO 1C469-1222	(7) Slightly left of centerline at Station 132.00 bottom, just aft of baggage compartment
TRIM SENSOR 1C326-198	(8) Under floorboard in the first bay aft of rear wing spar; at first bulkhead aft of flap motor near C/L of A/C just forward of Station 89.25
AMPLIFIER 1C515-1	(2) Aircraft radio rack in center nose section of A/C
STABILIZER (OPTIONAL) 1C359	(9) Just aft of partition between baggage compartment and aft fuselage, co-pilot's side
SWITCH BOX 1B405	(10) Under aircraft floorboard, just forward of rear wing spar (near roll servo) pilot's side
INVERTER 48C17	(11) Aircraft radio rack in center nose section of aircraft

SERVICING DATA

Roll Servo Clutch Setting (lbs): $43 \begin{smallmatrix} +7 \\ -8 \end{smallmatrix}$
 Pitch Servo Clutch Setting (lbs): 24 ± 4
 Pitch Trim Servo Clutch Setting (lbs): 25 ± 5
 Trim Sensor Point Gap (in.): $.014 \pm .002$
 Bridle Cable(s): Roll - 30B221 Pitch - 30B276
 Limitations Placard Part Number: 13A388-222

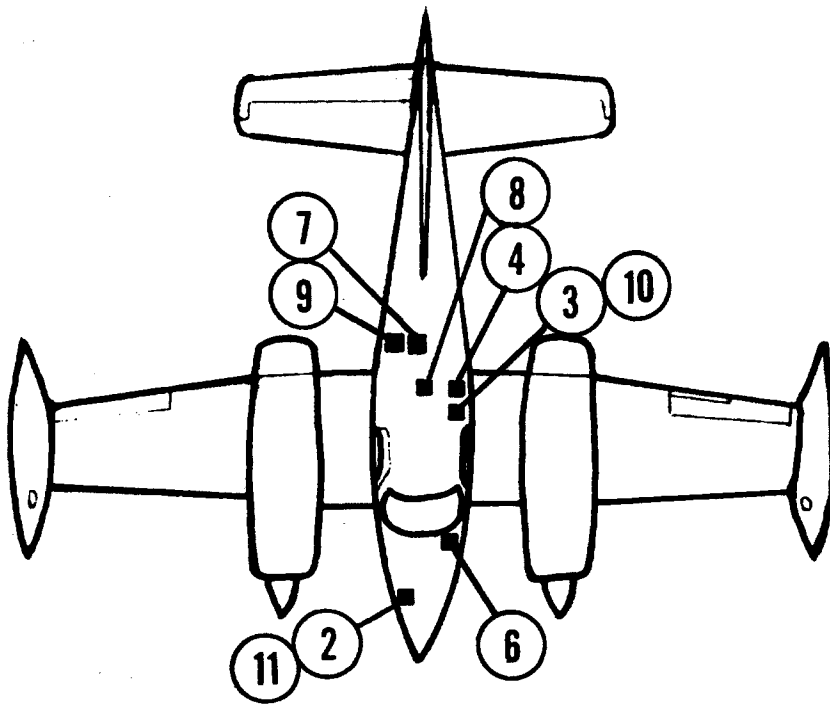
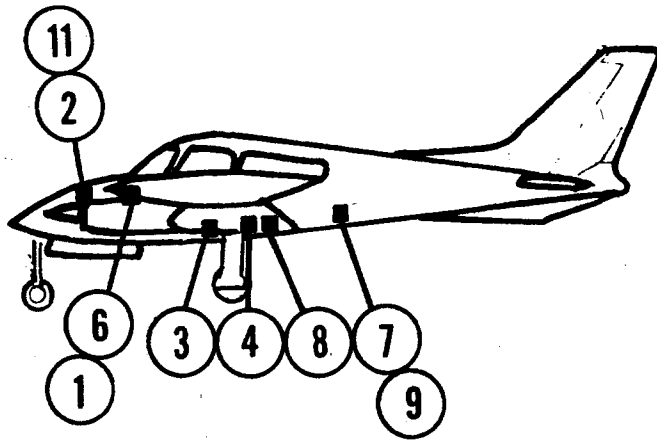

AK198

CESSNA

310K, 310L, 310N, 320E, 320F

CENTURY III

AK198
STC SA621SW

CESSNA 310K, 310L, 310N,
320E AND 320F

PART DESCRIPTION AND NOMENCLATURE	LOCATION
ROLL SIGNAL FILTER 1B440	(1) Under instrument panel, near artificial horizon
CONSOLE 1C404	(1) In pedestal beneath throttle controls
ARTIFICIAL HORIZON 52D67	(1) Instrument panel
DIRECTIONAL GYRO 52D54	(1) Instrument panel
ROLL SERVO 1D414-198R	(3) Under floor, just forward of rear spar, pilot's side
PITCH SERVO 1D414-198P	(4) Under floor, just aft of rear spar, pilot's side of A/C
ALTITUDE HOLD 1C407	(6) On angle brace of instrument panel, mount pilot's side
MAIN CABLE HARNESS 30D207-4	
RELAY BOX 1B405	(10) Under floor, just forward of rear spar, pilot's side
GYRO-AMPLIFIER 1C359	(9) Aft of baggage compartment, rear partition, co-pilot's side
RADIO COUPLER 1C388	(1) Instrument panel
TRIM SERVO 1D368-190	(7) Just aft of baggage compartment, partition on bottom, centerline of A/C
TRIM SENSOR 1C326-198	(8) Under floor, first bay aft of rear spar, at first bulkhead aft of flap motor on C/L of A/C
TRIM SWITCH 30B192	Pilot's control wheel
AMPLIFIER 1D395	(2) On aircraft radio rack in nose section of aircraft, center to right side
INVERTER 48C17	(11) On aircraft radio rack, nose section, centerline of A/C to right side

SERVICING DATA

Roll Servo Clutch Setting (lbs): 45 ± 5
 Pitch Servo Clutch Setting (lbs): 23 ± 2
 Pitch Trim Servo Clutch Setting (lbs): 25 ± 5
 Trim Sensor Point Gap (in.): $.014 \pm .002$
 Bridle Cable(s): Roll - 30B221 Pitch - 30B276
 Limitations Placard Part Number: 13A329-198

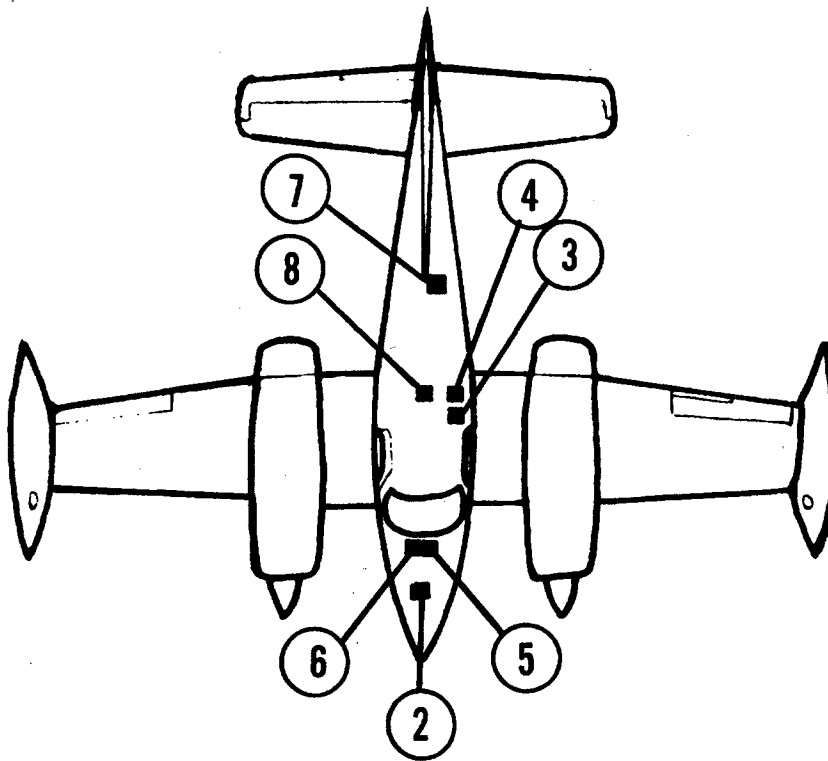
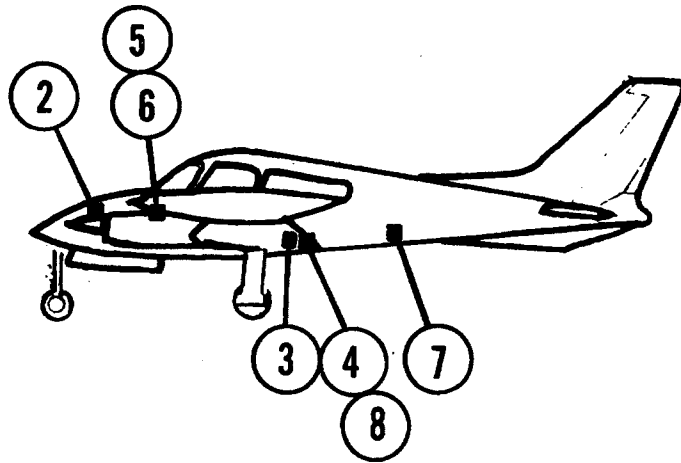

AK300

CESSNA

310P, 310Q, T310P and T310Q

CENTURY III

AK300
STC SA1142SW

CESSNA 310P, 310Q,
T310P AND T310Q

PART DESCRIPTION AND NOMENCLATURE	LOCATION
CONSOLE 1C404	(1) In pedestal below throttle controls
ARTIFICIAL HORIZON 52D67	(1) Instrument panel
DIRECTIONAL GYRO 52D54	(1) Instrument panel
ROLL SERVO 1C465-1-300R	(3) Just forward of aft spar, at Station 58.75 outboard of stringer on left side, under floor
PITCH SERVO 1C470-1-300P	(4) Just aft of Station 69.203 (rear spar) and left of flap motor, under floor, left side
ALTITUDE HOLD 1C407-1	(6) On forward cabin bulkhead right of center line of A/C
MAIN CABLE HARNESS 30D207-4	
RELAY BOX 1A526-1	(5) Under instrument panel
RADIO COUPLER 1C388	(1) Instrument panel
GLIDE SLOPE COUPLER 1C493	(1) Under instrument panel within 3 feet of artificial horizon
G. S. COUPLER HARNESS 30C291	
TRIM SERVO 1C469-1-300	(7) Just aft of baggage compartment at Station 132.00 at bottom of fuselage and left of A/C C/L
TRIM SENSOR 1C326-300	(8) Under floor, aft of rear spar at Station 89.25 near centerline
AMPLIFIER 1D395 OR 1D515 OR 1D515-1	(2) On aircraft radio rack, center

SERVICING DATA

Roll Servo Clutch Setting (lbs): $43 \begin{smallmatrix} +7 \\ -8 \end{smallmatrix}$
 Pitch Servo Clutch Setting (lbs): 24 ± 4
 Pitch Trim Servo Clutch Setting (lbs): 25 ± 1
 Trim Sensor Point Gap (in.): $.012 \pm .002$
 Bridle Cable(s): Roll - 30B221 Pitch - 30B276
 Limitations Placard Part Number: SEE AFM SUPPLEMENT

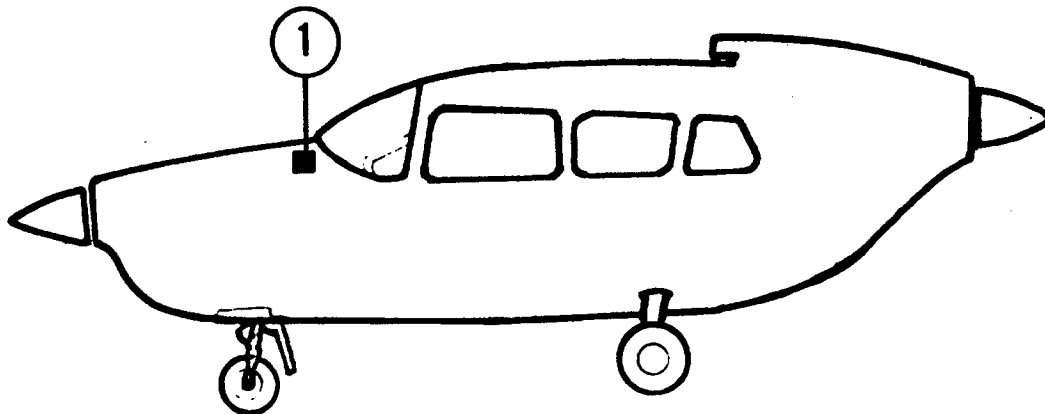
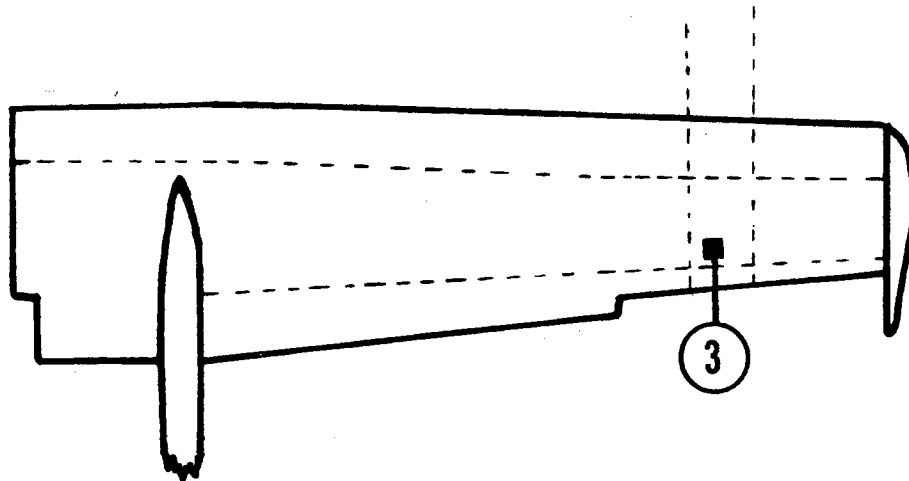

AK244

CESSNA SKYMASTER

337A, 337B, T337B, 337C, T337C, 337D

CENTURY II

AK244
STC SA801SW

CESSNA 337A, 337B, T337B,
337C, T337C, AND 337D

PART DESCRIPTION AND NOMENCLATURE	LOCATION
CONSOLE-AMPLIFIER 1C385-24	(1) Instrument panel
ROLL SIGNAL FILTER 1B440	(1) Under instrument panel near artificial horizon
ARTIFICIAL HORIZON 52D66	(1) Instrument panel
DIRECTIONAL GYRO 52D54	(1) Instrument panel
ROLL SERVO 1C470-210R	(3) In right wing aft aileron bellcrank assembly, forward of rear spar, 7 inches outboard of Station 177.00
MAIN CABLE HARNESS 30C198	
RADIO COUPLER (OPT.) 1C388	(1) Instrument panel

SERVICING DATA

Roll Servo Clutch Setting (lbs): 40 ± 5

Pitch Servo Clutch Setting (lbs):

Pitch Trim Servo Clutch Setting (lbs):

Trim Sensor Point Gap (in.):

Bridle Cable(s): Roll - 30B308 or 30B259

Limitations Placard Part Number: 13A344-244

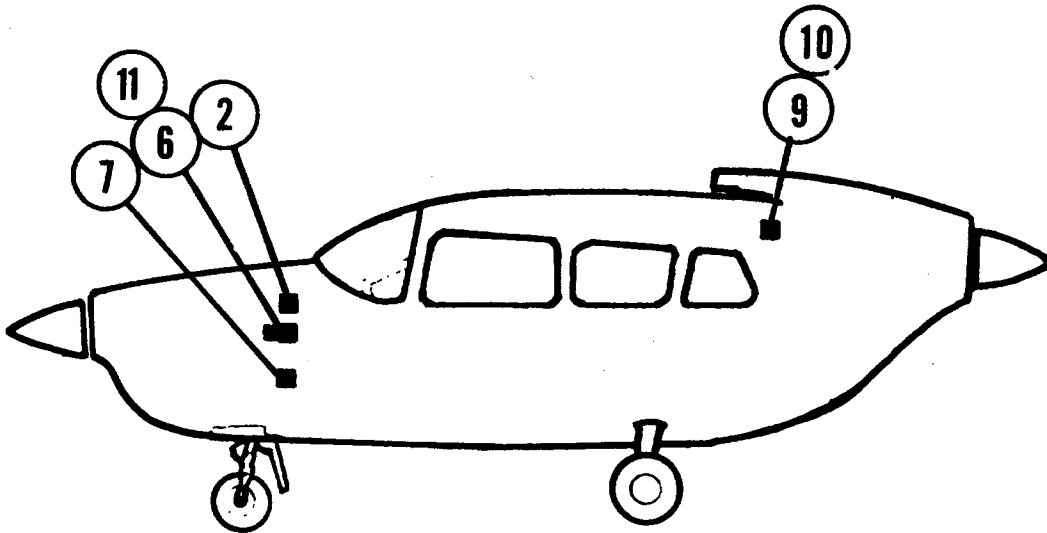
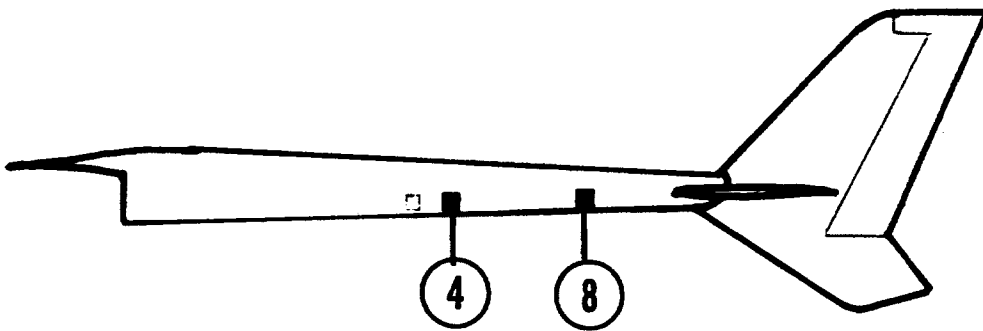
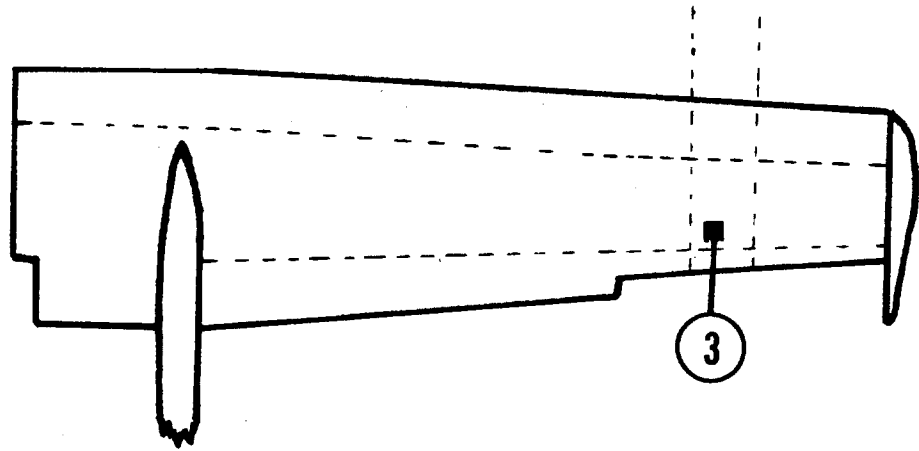

AK210

CESSNA SKYMASTER

337A

CENTURY III

AK210
STC SA668SW

CESSNA 337A

PART DESCRIPTION AND NOMENCLATURE	LOCATION
ROLL SIGNAL FILTER 1B440	(1) Under instrument panel near artificial horizon
CONSOLE 1C404	(1) Lower portion of pedestal
ARTIFICIAL HORIZON 52D67	(1) Instrument panel
DIRECTIONAL GYRO 52D54	(1) Instrument panel
ROLL SERVO 1C470-210R	(3) In right wing, aft of aileron bellcrank assembly, forward of rear spar, 7 inches outboard of Station 177.00
PITCH SERVO 1C470-210P	(4) In left tail boom 7.5 inches forward of Station 124.50, at large inspection hole
ALTITUDE HOLD 1C407	(6) Above pilot's control wheel shaft and just aft of the forward firewall
MAIN CABLE HARNESS 30D207-1	(10) Just forward of aft cabin firewall, between headliner and A/C top skin, on C/L on gyro-amplifier mounting bracket
RELAY BOX 1B405-24	(9) Just forward of aft cabin firewall, between headliner and A/C top skin, on C/L
GYRO-AMPLIFIER 1C359	Instrument panel
RADIO COUPLER 1C388	(7) Under instrument panel, just aft of forward firewall left side of C/L of A/C
TRIM SERVO 1D368-190	(8) In left tail boom at small inspection hole, near Station 153.25
TRIM SENSOR 1C365-210	Pilot's control wheel
TRIM SWITCH 30B192	(2) Above pilot's control wheel shaft and just aft of forward firewall on altitude hole mounting bracket
AMPLIFIER 1D395	(11) On forward firewall in cabin compartment above trim servo, left side of C/L of A/C
INVERTER 48A17	

SERVICING DATA

Roll Servo Clutch Setting (lbs): 40 ± 5
 Pitch Servo Clutch Setting (lbs): 20 ± 2
 Pitch Trim Servo Clutch Setting (lbs): 25 ± 5
 Trim Sensor Point Gap (in.): $.008 \pm .002$
 Bridle Cable(s): Roll - 30B308 Pitch - 30B260
 Limitations Placard Part Number: 13A329-210

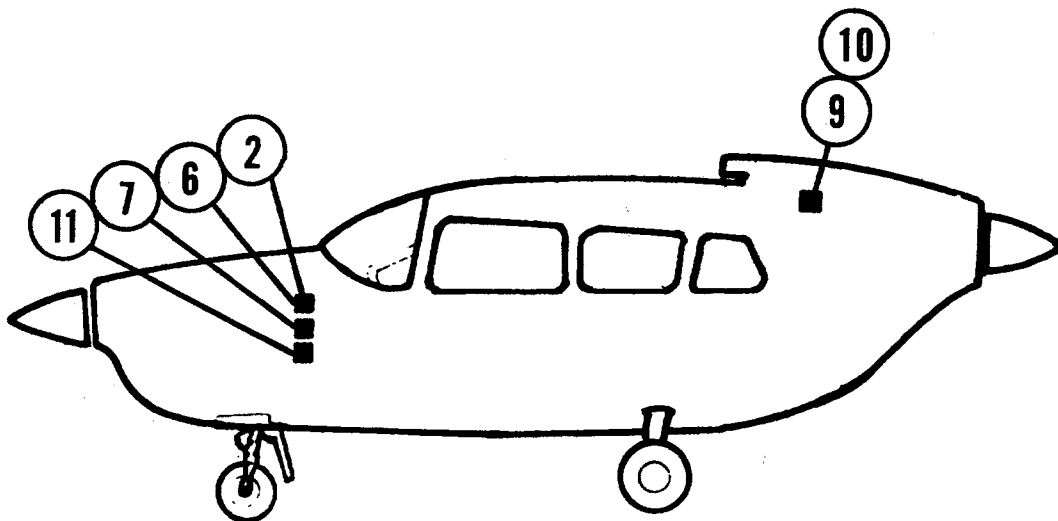
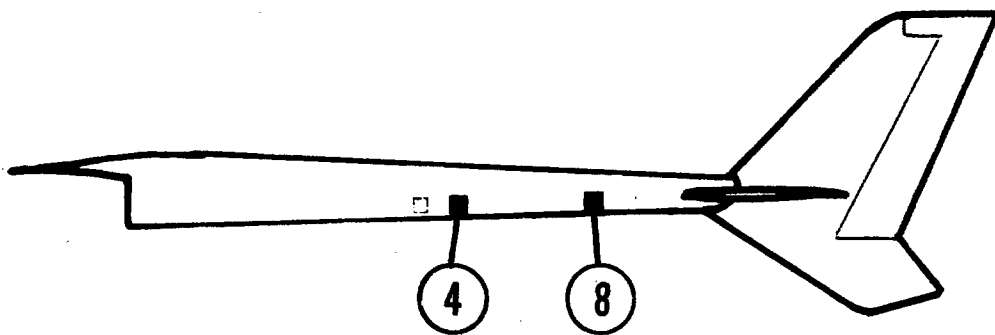
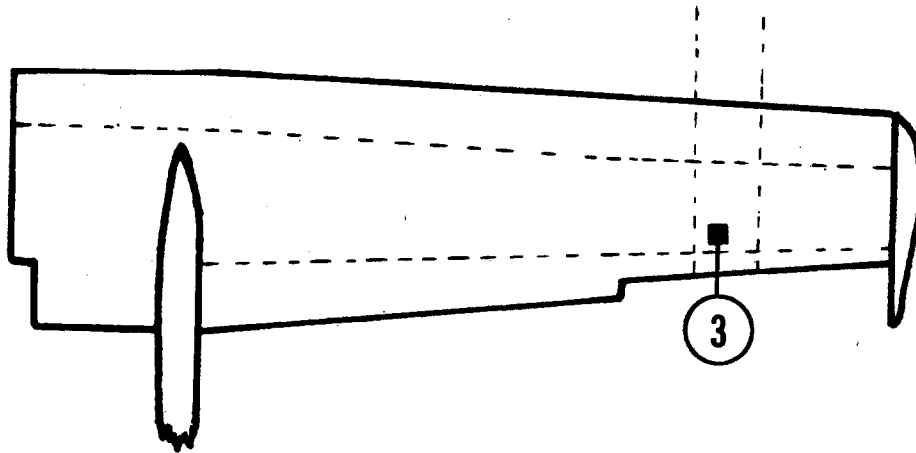

AK252

CESSNA SKYMASTER

337B, T337B, 337C, T337C

CENTURY III

AK252
STC SA842SW

CESSNA 337B, T337B, 337C
AND T337C

PART DESCRIPTION AND NOMENCLATURE	LOCATION
ROLL SIGNAL FILTER 1B440 (used only with 1D395 Amplifier)	(1) Under instrument panel near artificial horizon
CONSOLE 1C404	(1) Lower portion of instrument panel
ARTIFICIAL HORIZON 52D67	(1) Instrument panel
DIRECTIONAL HORIZON 52D54	(1) Instrument panel
ROLL SERVO 1C470-252R	(3) In right wing aft of aileron bellcrank assembly, forward of rear spar 7 inches outboard of Station 177.00
PITCH SERVO 1C470-210P	(4) In left tail boom, 7.5 inches forward of station 124.50, at large inspection hole
ALTITUDE HOLD 1C470	(6) Above pilot's control wheel shaft and just aft of the forward firewall.
MAIN CABLE HARNESS 30D207-1	
RELAY BOX 1B405-24	(10) Just forward of aft cabin firewall, between headliner and A/C top skin, on C/L on gyro-amplifier mounting bracket
GYRO-AMPLIFIER 1C359	(9) Just forward of aft cabin firewall, between headliner and A/C top skin on C/L
RADIO COUPLER 1C388	(1) Instrument panel
TRIM SERVO 1D368-252	(7) Under instrument panel, just aft of forward firewall, left side of C/L of A/C
TRIM SENSOR 1C365-210	(8) In left boom at small inspection hole, near Station 153.25;
AMPLIFIER 1C515 or 1D395	(2) Above pilot's control wheel shaft and just aft of forward firewall, on altitude hold mounting bracket
INVERTER 48C17	(11) On forward firewall in cabin compartment above trim servo, left side of C/L of A/C

SERVICING DATA

Roll Servo Clutch Setting (lbs): 45 ± 5
 Pitch Servo Clutch Setting (lbs): 20 ± 1
 Pitch Trim Servo Clutch Setting (lbs): 30 ± 5
 Trim Sensor Point Gap (in.): $.008 \pm .002$
 Bridle Cable (s): Roll - 30B259 Pitch - 30B260
 Limitations Placard Part Number: 13A329-252

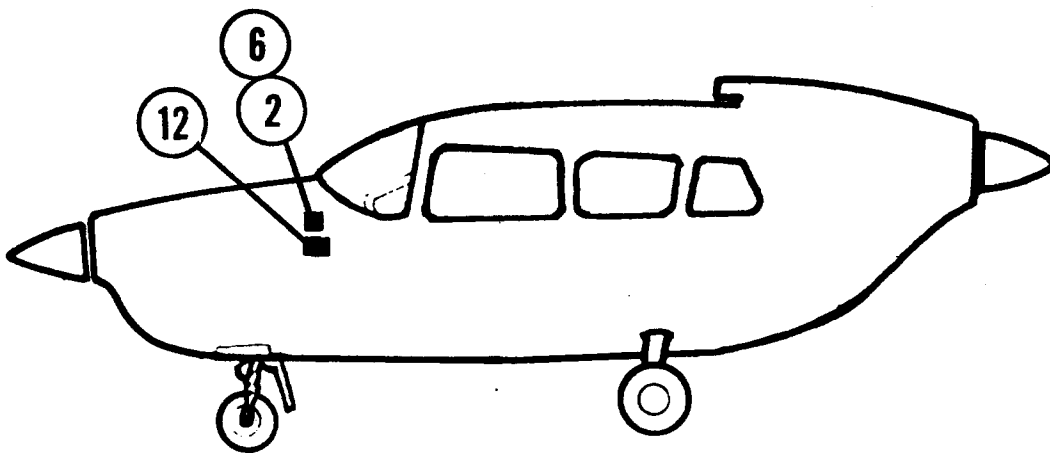
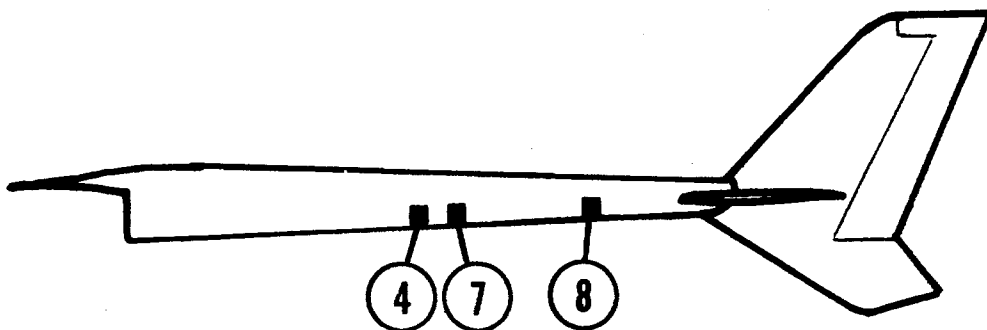
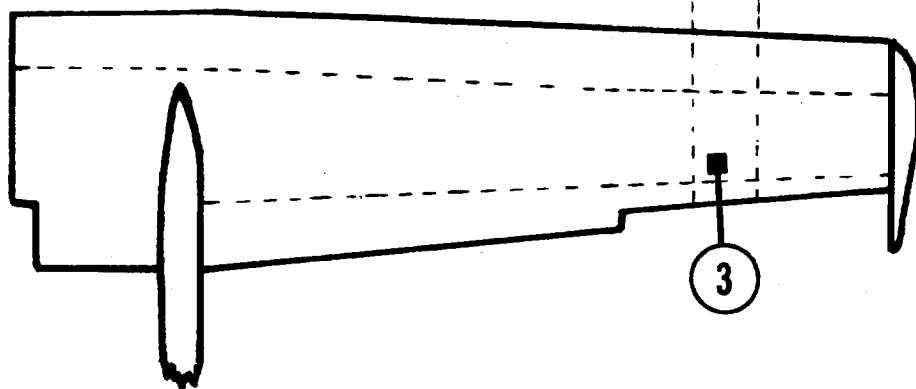

AK345

CESSNA SKYMASTER

337E, 337F

CENTURY III

AK345
STC SA1428 SW

CESSNA 337E AND 337F

PART DESCRIPTION AND NOMENCLATURE	LOCATION
CONSOLE 1C404	(1) Lower portion of pedestal
ARTIFICIAL HORIZON 52D67	(1) Instrument panel
DIRECTIONAL GYRO 52D54	(1) Instrument panel
ROLL SERVO 1C465-1-345R	(3) In right wing, approximately 7 inches outboard of Station 177.00, forward of rear spar
PITCH SERVO 1C470-1-345P	(4) In left tail boom, approximately 7.5 inches forward of Station 124.50, at large inspection hole
ALTITUDE HOLD 1C407	(6) Above pilot's control wheel shaft and just aft of forward firewall
MAIN CABLE HARNESS 30D207-1	
ACCELEROMETER 1C741-1	(12) Between Instrument panel and forward cabin bulkhead (approximately 6 3/4 inches forward of instrument panel right side.)
RADIO COUPLER 1C388	(1) Instrument panel
GLIDE SLOPE COUPLER 1C493	(1) Behind instrument panel within 3 feet of artificial horizon
G.S. COUPLER HARNESS 30C291	
TRIM SERVO 1C469-345	(7) Approximately 1/4 inch forward of Station 124.50 in right tail boom, at large inspection hole
TRIM SENSOR 1C742-345	(8) In small inspection hole at Station 153.24 in left tail boom
TRIM SWITCH 30B416-2	Pilot's control wheel
TRIM AMP 1C671-1	(7) In right tail boom at Station 110.50
AMPLIFIER 1C515-1	(2) Mounted on altitude hold bracket above pilot's control wheel shaft and aft of forward firewall

SERVICING DATA

Roll Servo Clutch Setting (lbs):

Pitch Servo Clutch Setting (lbs):

Pitch Trim Servo Clutch Setting (lbs):

Trim Sensor Point Gap (in.):

Bridle Cable (s): Roll - 30B308-1 Pitch - 30B260

Limitations Placard Part Number:

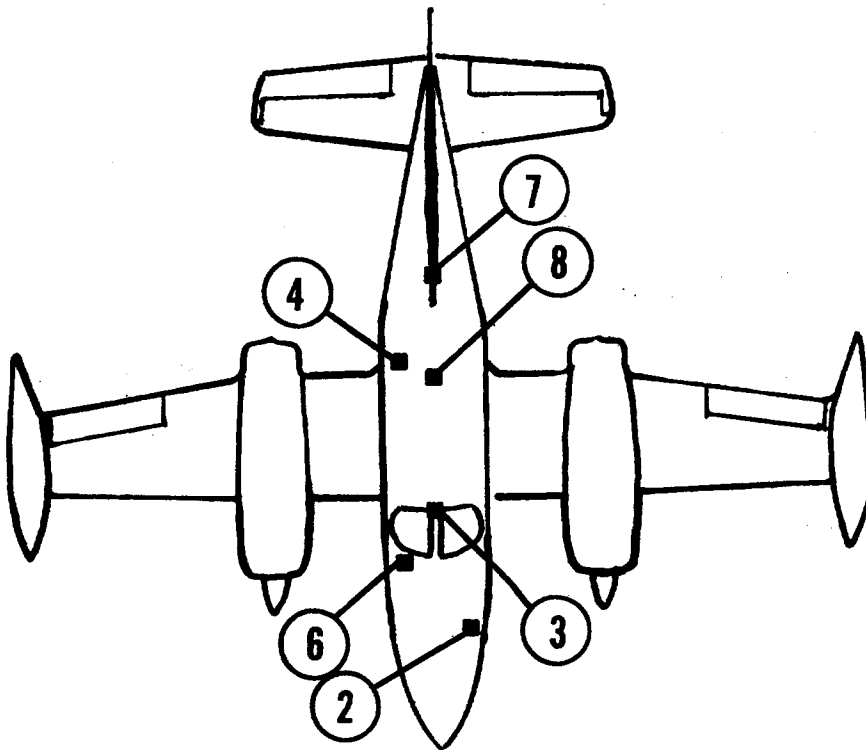
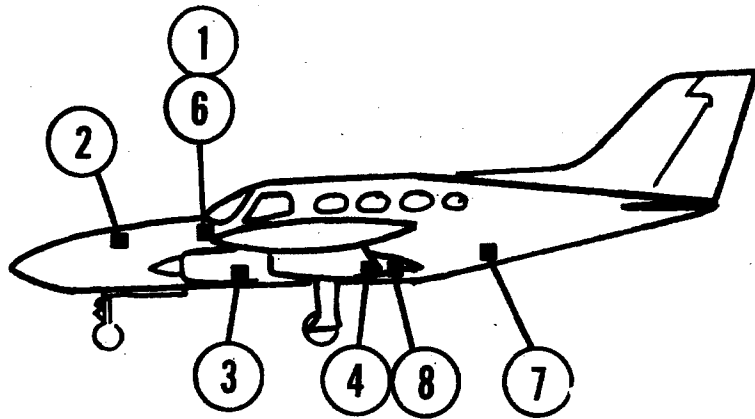

AK302

CESSNA

401, 401A, 401B, 402, 402A, 402B

CENTURY III

AK302
STC SA1206SW

CESSNA 401, 401A, 401B, 402
402A AND 402B

PART DESCRIPTION AND NOMENCLATURE	LOCATION
ROLL SIGNAL FILTER 1B440 (1D395 ONLY)	(1) Under instrument panel near artificial horizon
CONSOLE 1C404	(1) In pedestal below throttles
ARTIFICIAL HORIZON 52D67	(1) Instrument panel
DIRECTIONAL GYRO 52D54	(1) Instrument panel
ROLL SERVO 1C465-1-240R	(3) Under floor in bay just aft of station 118.55 and under pilot and co-pilot seats
PITCH SERVO 1C465-1-240P	(4) Just aft of bulkhead at Station 213.60, between floorboard and lower skin, right side
ALTITUDE HOLD 1C407	(6) Forward of instrument panel on co-pilot's side
RELAY BOX 1A526-1	(5) Under instrument panel
MAIN CABLE HARNESS 30D207-4	
RADIO COUPLER 1C388	(1) Instrument panel
GLIDE SLOPE COUPLER 1C493	(1) Behind instrument panel within 3 feet of artificial horizon
G.S. COUPLER HARNESS 30C291	
TRIM SERVO 1C469-1-302	(7) At first bulkhead aft of baggage compartment at Station 289.94 near C/L or A/C
TRIM SENSOR 1C476-302	(8) Under the floor, forward of bulkhead Station 237.00, near C/L of A/C
TRIM SWITCH 30A354	Pilot's control wheel
AMPLIFIER 1D395 OR 1C515 OR 1C515-1	(2) Mounted on aircraft radio rack top center or left side

SERVICING DATA

Roll Servo Clutch Setting (lbs): 45 ± 5
 Pitch Servo Clutch Setting (lbs): 27 ± 2
 Pitch Trim Servo Clutch Setting (lbs): 19 ± 2
 Trim Sensor Point Gap (in.): $.014 \pm .002$
 Bridle Cable (s): Roll - 30B258 Pitch - 30B268
 Limitations Placard Part Number: See AFM Supplement

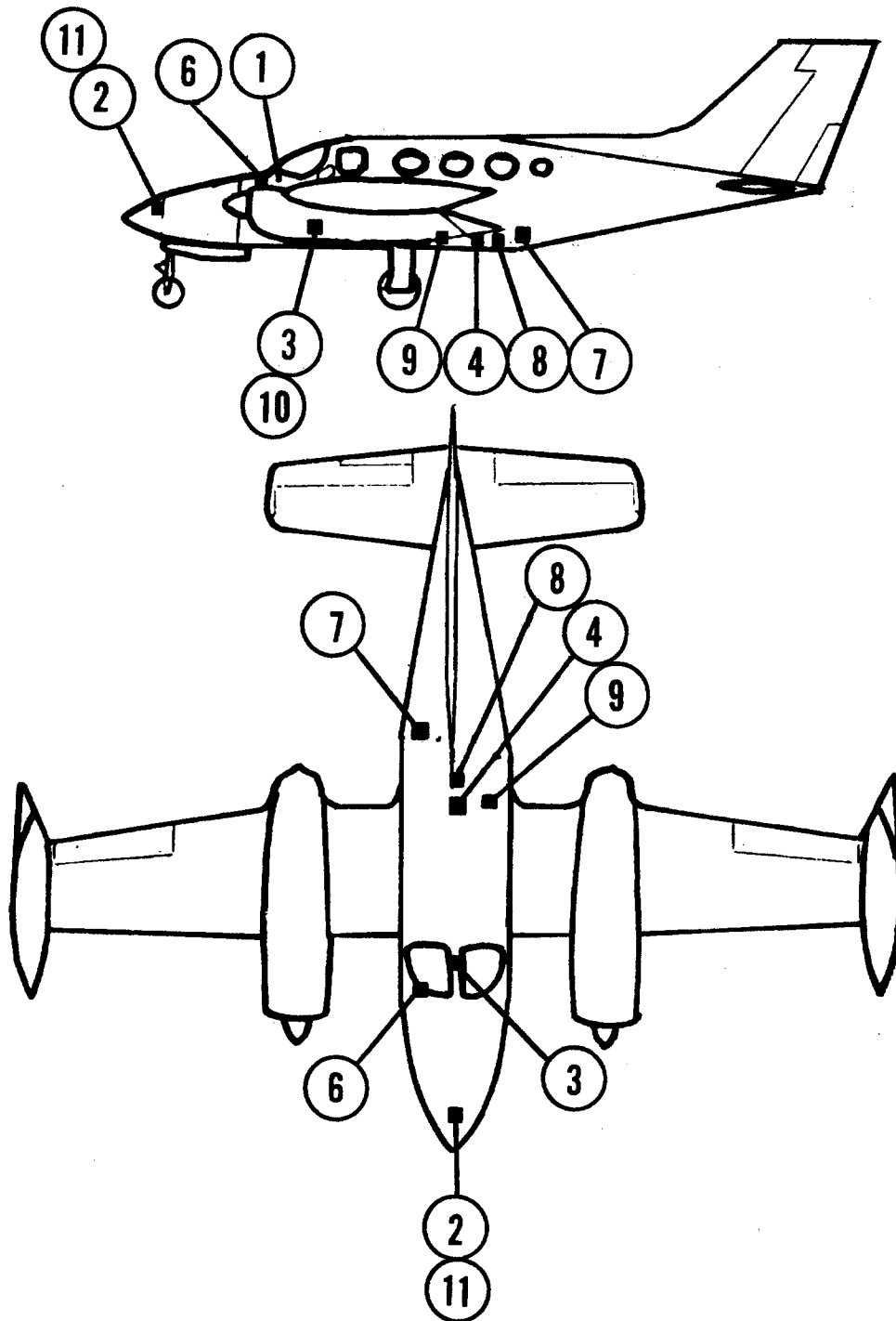

AK216

CESSNA

411, 411A

CENTURY III

AK216
STC SA681SW

CESSNA 411 AND 411A

PART DESCRIPTION AND NOMENCLATURE	LOCATION
ROLL SIGNAL FILTER 1B440 (1D395 ONLY)	(1) Under instrument panel near artificial horizon
CONSOLE 1C404	(1) In pedestal under throttle controls
ARTIFICIAL HORIZON 52D67	(1) Instrument panel
DIRECTIONAL GYRO 52D54	(1) Instrument panel
ROLL SERVO 1D414-216R	(3) Under the floor between pilot and co-pilot seats
PITCH SERVO 1D414-216P	(4) Under floor just aft of airstair door forward bulkhead in center
ALTITUDE HOLD 1C407	(6) Forward of instrument panel on co-pilot's side of aircraft
MAIN CABLE HARNESS 30D207-4	
RELAY BOX 1B405-24	(10) On roll Servo mounting bracket
GYRO-AMPLIFIER 1C359	(9) Under floor, pilot's side, forward side of bulkhead just forward of cabin entrance
RADIO COUPLER 1C388	Instrument panel
TRIM SERVO 1D368-159	(7) At first bulkhead aft of baggage compartment in tail section, left side
TRIM SENSOR 1C476-216	(8) At aft airstair door post bulkhead in center of aircraft
TRIM SWITCH 30B192	Pilot's control wheel
AMPLIFIER 1D395	(2) Mounted on forward aircraft radio rack in nose section, right side or center
INVERTER 48C17	(11) On forward nose radio rack right side or center

SERVICING DATA

Roll Servo Clutch Setting (lbs): 45 ± 5
 Pitch Servo Clutch Setting (lbs): 23 ± 2
 Pitch Trim Servo Clutch Setting (lbs): 33 Min. 33 Max
 Trim Sensor Point Gap (in.): $.014 \pm .002$
 Bridle Cable (s): Roll - 30B321 Pitch - 30B268
 Limitations Placard Part Number: See AFM Supplement

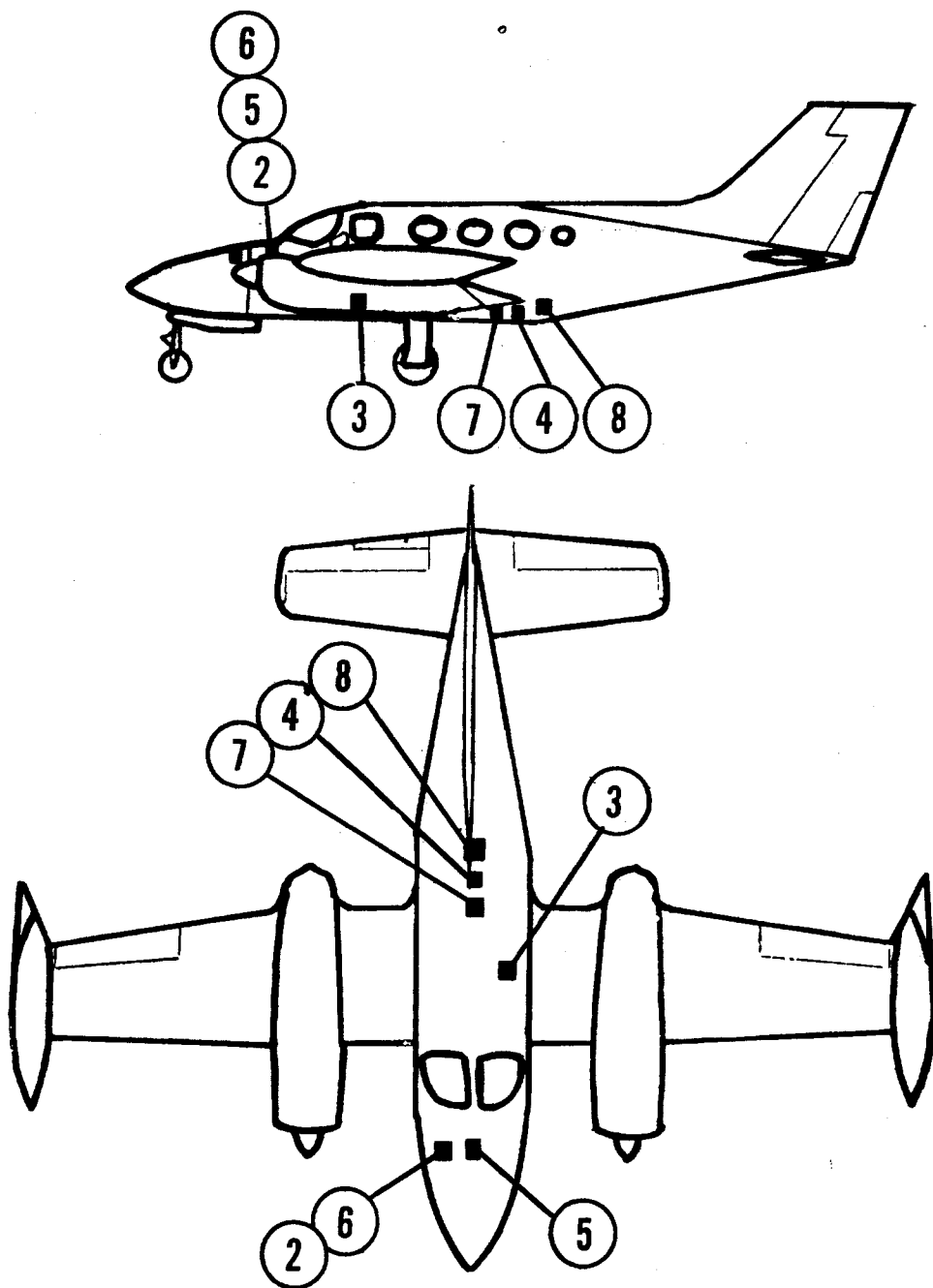

AK308

CESSNA

414

CENTURY III

AK308
STC SA1219SW

CESSNA 414

PART DESCRIPTION AND NOMENCLATURE	LOCATION
CONSOLE 1C404	(1) In pedestal beneath throttle controls
ARTIFICIAL HORIZON 52D67	(1) Instrument panel
DIRECTIONAL GYRO 52D54	(1) Instrument panel
ROLL SERVO 1C465-1-308R	(3) Under cabin floor just aft of Station 176.50 left side
PITCH SERVO 1C470-1-308P	(4) Under floor, opposite the cabin door opening, between Stations 212.50 and 225.50 on C/L of A/C
ALTITUDE HOLD 1C407	(6) Under instrument panel on the right
MAIN CABLE HARNESS 30D207-4	
RELAY BOX 1A526-1	(5) Under instrument panel
RADIO COUPLER 1C388	(1) Instrument panel
TRIM SERVO 1C469-1-308	(7) Under floor, in first bay in front of the forward cabin door bulkhead, on centerline of A/C
TRIM SENSOR 1C476-279	(8) Under the floor, on the forward side of bulkhead Station 238.13 on A/C C/L
TRIM SWITCH 30A364	Pilot's control wheel
AMPLIFIER 1C515 OR 1C515-1	(2) Under instrument panel, right with altitude hold

SERVICING DATA

Roll Servo Clutch Setting (lbs): 43 ± 7
 Pitch Servo Clutch Setting (lbs): 22 ± 5
 Pitch Trim Servo Clutch Setting (lbs): 20 ± 5
 Trim Sensor Point Gap (in.): $.014 \pm .002$
 Bridle Cable (s): Roll - 30B329 Pitch - 30B218
 Limitations Placard Part Number: SEE AFM SUPPLEMENT

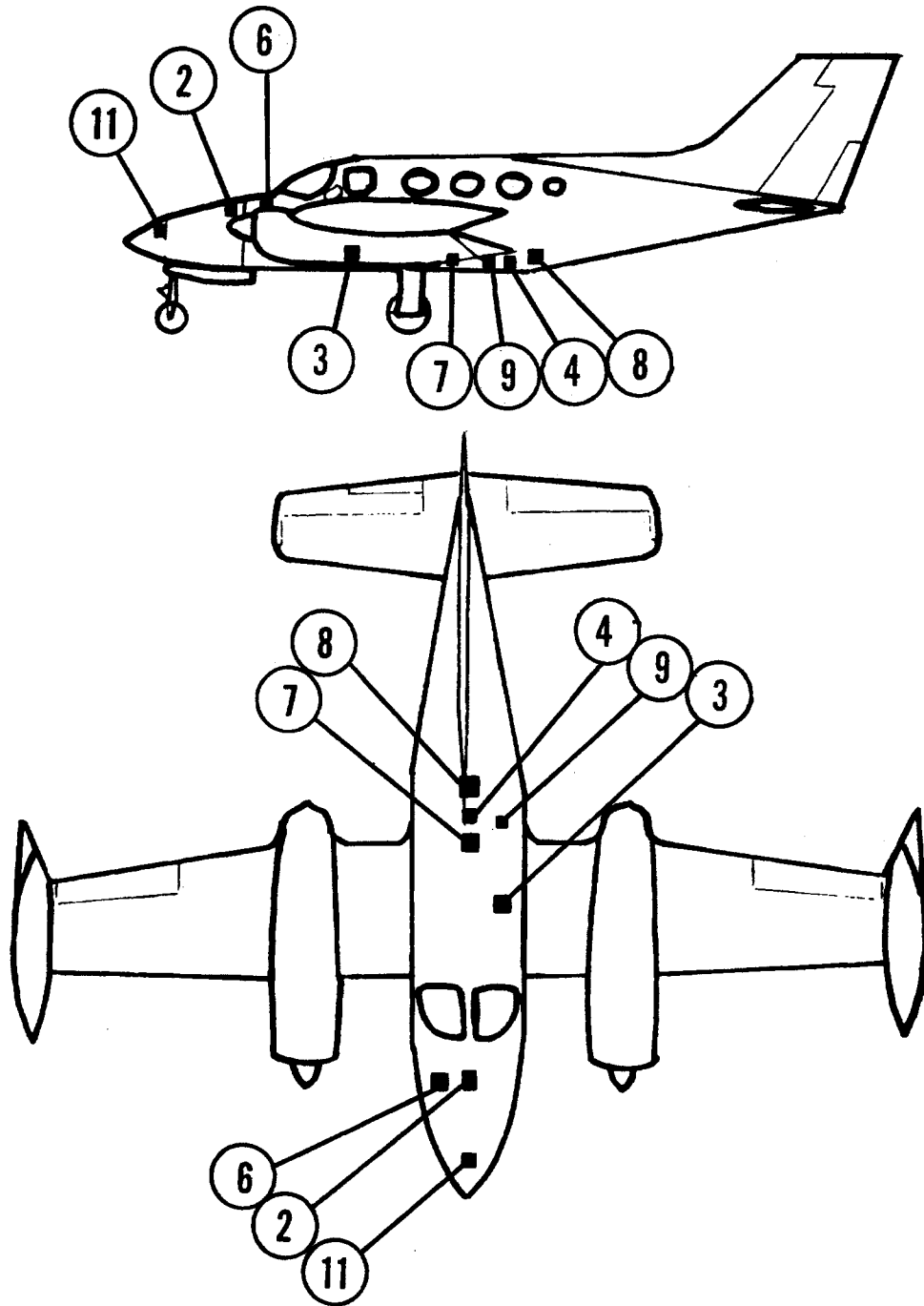

AK279

CESSNA

421, 421A

CENTURY III

AK279
STC SA968SW

CESSNA 421 AND 421A

PART DESCRIPTION AND NOMENCLATURE	LOCATION
CONSOLE 1C404	(1) In pedestal beneath throttle controls
ARTIFICIAL HORIZON 52D67	(1) Instrument panel
DIRECTIONAL GYRO 52D54	(1) Instrument panel
ROLL SERVO 1C470-1-279R	(3) Under cabin floor just aft of Station 176.50 on left side
PITCH SERVO 1C470-1-279P	(4) Under cabin floor, on centerline, opposite cabin door opening
ALTITUDE HOLD 1C407	(6) On co-pilot's side of aircraft, forward of instrument panel
MAIN CABLE HARNESS 30D207-4	
RELAY BOX 1B405-24	(10) Mounted on roll servo mounting bracket
GYRO-AMPLIFIER 1C359	(9) Under floor, pilot's side, in first bay aft of forward cabin door bulkhead
RADIO COUPLER 1C388	(1) Instrument panel
TRIM SERVO 1C469-1-279	(7) Under floor in first bay in front of forward cabin door bulkhead, in center of A/C
TRIM SENSOR 1C476	(8) Under floor on centerline forward side of bulkhead Station 238.13
TRIM SWITCH 30A204	Pilot's control wheel
AMPLIFIER 1C515	(2) In nose section of aircraft on centerline directly forward of forward pressure bulkhead
INVERTER 48C17	(11) In forward nose radio rack

SERVICING DATA

Roll Servo Clutch Setting (lbs): $53 \begin{smallmatrix} +2 \\ -3 \end{smallmatrix}$
 Pitch Servo Clutch Setting (lbs): 22 ± 3
 Pitch Trim Servo Clutch Setting (lbs): $23 \begin{smallmatrix} +2 \\ -3 \end{smallmatrix}$
 Trim Sensor Point Gap (in.): $.014 \pm .002 \begin{smallmatrix} +2 \\ -3 \end{smallmatrix}$
 Bridle Cable (s): Roll - 30B329 Pitch - 30B268
 Limitations Placard Part Number: See AFM Supplement

AK219

DEHAVILAND DOVE

DH-104-6A

DEHAVILLAND

CENTURY III

AK219
STC SA676SW

DEHAVILAND DH-104-6A DOVE

PART DESCRIPTION AND NOMENCLATURE	LOCATION
ROLL SIGNAL FILTER 1B440	(1) Under instrument panel near artificial horizon
CONSOLE 1C404	(1) Instrument panel
ARTIFICIAL HORIZON 52D67	(1) Instrument panel
DIRECTIONAL GYRO 52D54	(1) Instrument panel
ROLL SERVO 1C465-1-219R	(3) Forward outboard corner of left main gear retraction hole, just aft of main spar
PITCH SERVO 1C465-1-219P	(4) Under floor just aft of main spar, right side
ALTITUDE HOLD 1C407	(6) On radio rack in forward nose, pilot's side
MAIN CABLE HARNESS 30D207-4	
RADIO COUPLER 1C388	(1) Instrument panel
TRIM SERVO 1C469-1-219	(7) Just forward of second bulkhead, aft of baggage compartment, right side
TRIM SENSOR 1D474-219	(8) Through access door No. 6 on right side under aft baggage compartment floor
TRIM SWITCH 30B192	Pilot's control wheel
AMPLIFIER 1D395	(2) On radio rack in forward nose, center

SERVICING DATA

Roll Servo Clutch Setting (lbs): 50 ± 5
 Pitch Servo Clutch Setting (lbs): 28 ± 2
 Pitch Trim Servo Clutch Setting (lbs): 25 ± 2
 Trim Sensor Point Gap (in.): $.010 \pm .002$
 Bridle Cable (s): Roll - 30B258 Pitch - 30B257
 Limitations Placard Part Number: See AFM Supplement

AK256

HELIO

H-250, H-295

CENTURY III

AK256
STC SA860SW

HELIO H-250 AND H-295

PART DESCRIPTION AND NOMENCLATURE	LOCATION
ROLL SIGNAL FILTER 1B440-1	(1) Under instrument panel, near artificial horizon
CONSOLE 1C404	(1) Instrument panel
ARTIFICIAL HORIZON 52D67	(1) Instrument panel
DIRECTIONAL GYRO 52D54	(1) Instrument panel
ROLL SERVO 1C456-256R	(3) In right wing at second rectangular inspection hole, outboard from fuselage, forward of main spar
PITCH SERVO 1C506-256P	(4) Under floor just aft of pilot's seat
ALTITUDE HOLD 1C407	(6) Just forward of instrument panel, under top cowling to right of defroster, pilot's side
MAIN CABLE HARNESS 30D207-3	
RADIO COUPLER 1C388	(1) Instrument panel
TRIM SERVO 1D360-178	(7) Mounted to rear of first bulkhead aft of baggage compartment, top center
TRIM SENSOR 1C377-178	(8) Mounted beneath baggage compartment floor, left side at bottom
TRIM SWITCH 30B192	Pilot's control wheel
AMPLIFIER 1D395	(2) Mounted on radio rack beneath pilot's or co-pilot's seat

SERVICING DATA

Roll Servo Clutch Setting (lbs): 45 ± 5
 Pitch Servo Clutch Setting (lbs): 17 ± 3
 Pitch Trim Servo Clutch Setting (lbs): 10 ± 2
 Trim Sensor Point Gap (in.): $.010 \pm .002$
 Bridle Cable (s): Roll - 30B221 Pitch - 30B260
 Limitations Placard Part Number: 13A329-256

AK223

MAULE

M-4, M-4C, M-4S, M-4T, M4-210, M4-.210C
M4-210S, M4-210+

CENTURY II

AK223
STC SA693SW

MAULE: M-4, M-4C, M-4S, 4-4T, M-4-210,
M-4-210C, M-4-210S and M-4-210T

PART DESCRIPTION AND NOMENCLATURE	LOCATION
Console-Amplifier 1C385	(1) Instrument panel
Roll Signal Filter 1B440	(1) Under instrument panel, near artificial horizon
Artificial Horizon 52D66	(1) Instrument panel
Directonal Gyro 52D54	(1) Instrument panel
Roll Servo 1D456-223R	(3) In right wing, inboard of third rib, outboard from fuselage.
Main Cable Harness 30C198	
Radio Coupler (Opt.) 1C388	(1) Instrument panel
Stabilizer Gyro-Amplifier 1C359	(9) On brace on aft side of baggage compartment partition and aft fuselage, left side
Switch Box 1B405	(10) On aft, side of baggage compartment partition, left side, near 1C359 Gyro-Amplifier
Trim Switch 30A204	Pilot's control wheel

SERVICING DATA

Roll Servo Clutch Setting (lbs): 40 ± 5
 Pitch Servo Clutch Setting (lbs):
 Pitch Trim Servo Clutch Setting (lbs):
 Trim Sensor Point Gap (in.):
 Bridle Cabel (s): Roll - 30B269
 Limitations Placard Part Number: 13A344-223

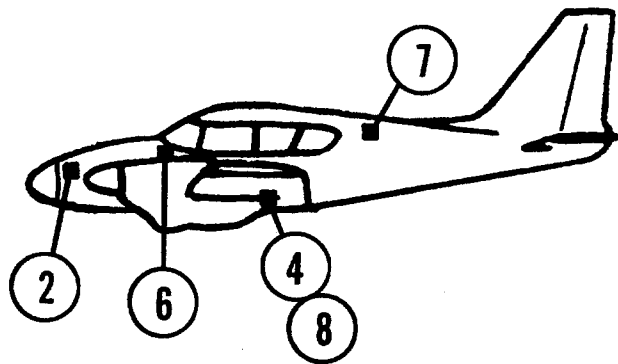
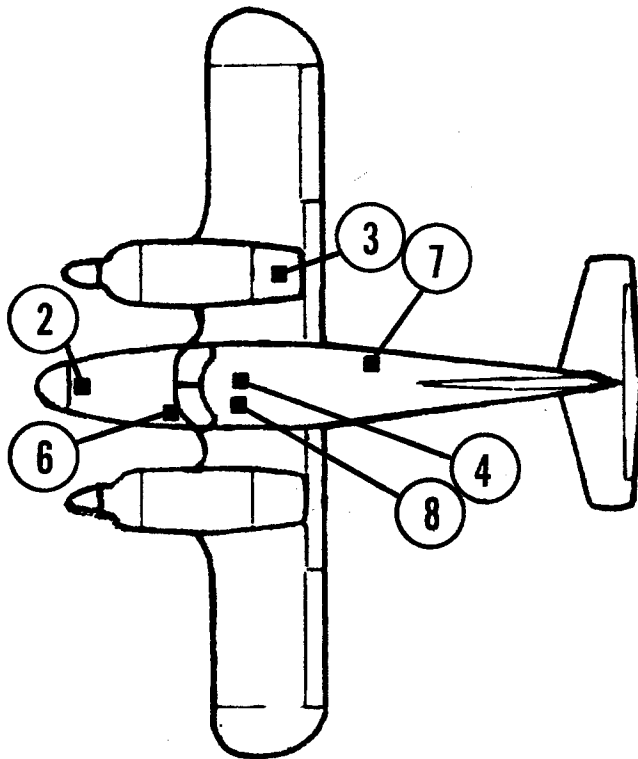

AK242

PIPER AZTEC

PA-23-235, PA-23-250, PA-E23-250

CENTURY III

AK242
STC SA921SW

PIPER PA-23-235, PA-23-250 and PA-E23-250

PART DESCRIPTION AND NOMENCLATURE	LOCATION
CONSOLE 1C404	(1) Lower left instrument panel
ARTIFICIAL HORIZON 52D67	(1) Instrument panel
DIRECTIONAL GYRO 52D54	(1) Instrument panel
ROLL SERVO 1C363-1-161R	(3) In right engine nacelle, just forward of main spar
PITCH SERVO 1C508-1-242P	(4) Just aft of main spar, under floor and center seats
ALTITUDE HOLD 1C407	(6) Under instrument panel, pilot's side
MAIN CABLE HARNESS 30D207-4	
RADIO COUPLER 1C388	(1) Instrument panel
TRIM SERVO 1D360	(7) At top of baggage compartment, right side
TRIM SENSOR 1C365-151	(8) Under floorboard and middle seats, pilot's side
TRIM SWITCH 30B192	Pilot's control wheel
AMPLIFIER 1D395	(2) Aircraft radio rack in nose section of aircraft in center

SERVICING DATA

Roll Servo Clutch Setting (lbs): 39 ± 5
 Pitch Servo Clutch Setting (lbs): 20 ± 3
 Pitch Trim Servo Clutch Setting (lbs): 25 ± 5
 Trim Sensor Point Gap (in.): $.010 \pm .002$
 Bridle Cable (s): Roll - 30B201 Pitch - 30B210
 Limitations Placard Part Number: 13A388-242

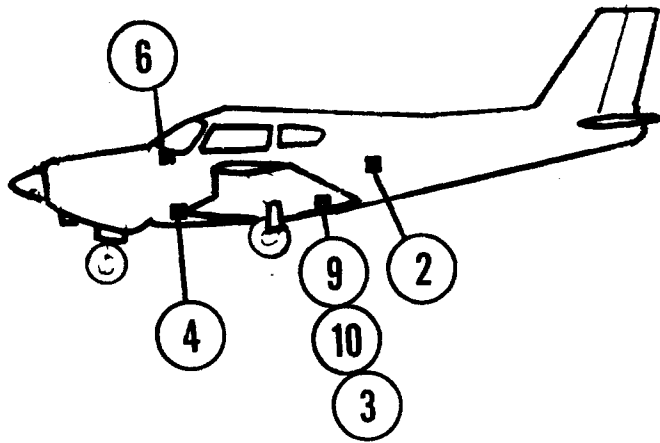
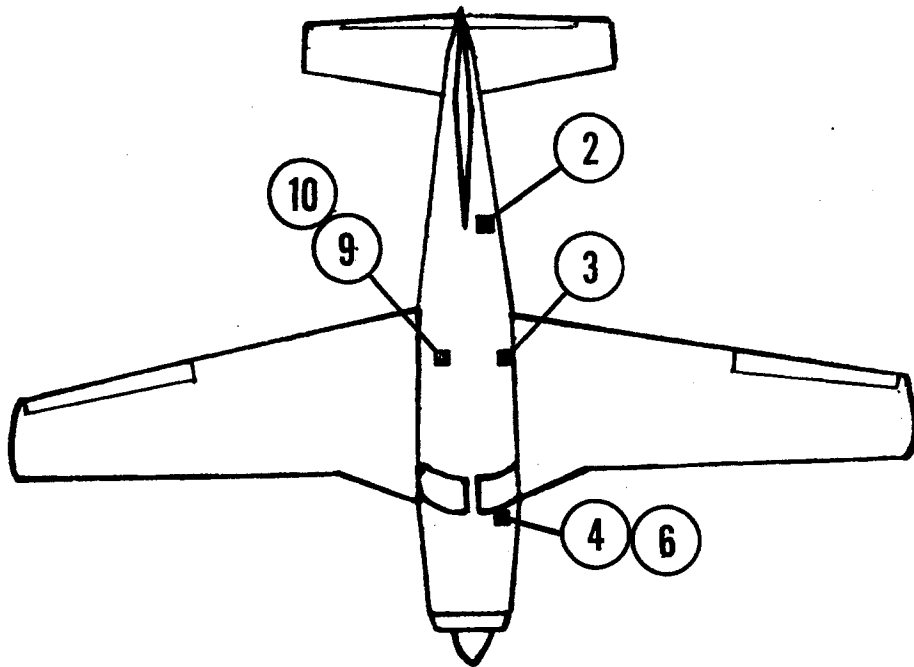

AK220

PIPER COMMANCHE

PA-24-250, PA-24-260

CENTURY III

AK220
STC SA662SW

PIPER PA-24-250, PA-24-260 AND PA-30

PART DESCRIPTION AND NOMENCLATURE	LOCATION
CONSOLE 1C404	(1) Instrument panel
ARTIFICIAL HORIZON 52D67	(1) Instrument panel
DIRECTIONAL GYRO 52D54	(1) Instrument
ROLL SERVO 1C363-1-161R	(3) Forward of rear spar under baggage compartment floor, left side
PITCH SERVO 1C363-1-186P	(4) Under floor beneath pilot's rudder pedals, left side
ALTITUDE HOLD 1C407	(6) Under top cowl cover, behind instrument panel, pilot's side
MAIN CABLE HARNESS 30D207-2	
RELAY BOX 1B405	(10) Approximately 6" forward of rear spar, right centerline. Under baggage compartment floor with gyro-amplifier
GYRO-AMPLIFIER 1C359	(9) Under baggage compartment floor, approximately 6" forward spar right centerline
RADIO COUPLER 1C388	(1) Instrument panel
TRIM SERVO 1C363-1-220	(7) Between fuselage Station 157 and 184 at top center
TRIM SENSOR 1C365-152	(8) Just aft of main spar below floor and rear seat, left side
TRIM SWITCH 30A204	Pilot's control wheel
AMPLIFIER 1D395	(2) Radio rack aft section of aircraft middle left side

SERVICING DATA

Roll Servo Clutch Setting (lbs): 39 ± 5
 Pitch Servo Clutch Setting (lbs): 15 ± 3
 Pitch Trim Servo Clutch Setting (lbs): 25 ± 5
 Trim Sensor Point Gap (in.): $.010 \pm .002$
 Bridle Cable (s): Roll - 30B199 Pitch - 30B212
 Limitations Placard Part Number: 13A329-220

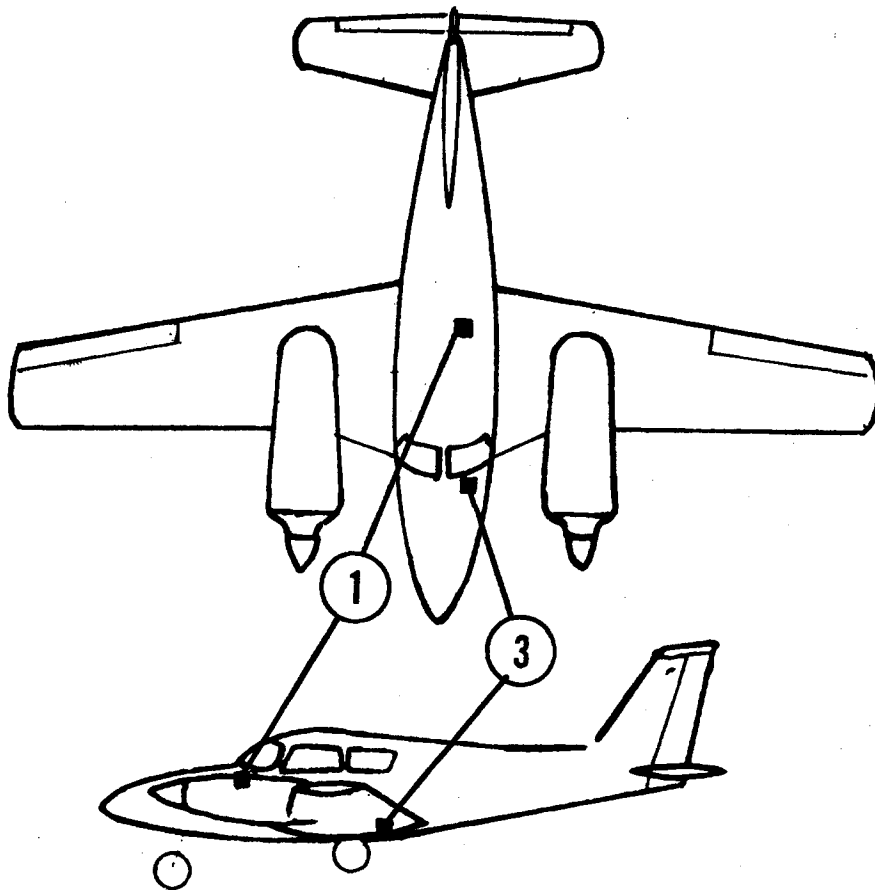

AK236

PIPER COMANCHE and TWIN COMANCHE PA-24-180, PA-24-250,
PA-24-260, PA-30

CENTURY II

AK236
STC SA756SW

PIPER PA-24, PA-24-250, PA-24-260
AND PA-30

PART DESCRIPTION AND NOMENCLATURE	LOCATION
CONSOLE-AMPLIFIER 1C385	(1) Instrument panel
ARTIFICIAL HORIZON 52D66	(1) Instrument panel
DIRECTIONAL GYRO 52D54	(1) Instrument panel
ROLL SERVO 1D363-161R	(3) Under baggage compartment floor, forward of rear wing spar, left centerline
MAIN CABLE HARNESS 30C198	
RADIO COUPLER (OPT.) 1C388	(1) Instrument panel

SERVICING DATA

Roll Servo Clutch Setting (lbs): 35 ± 5

Pitch Servo Clutch Setting (lbs):

Pitch Trim Servo Clutch Setting (lbs):

Trim Sensor Point Gap (in.):

Bridle Cable (s): Roll - 30B199

Limitations Placard Part Number: 13A344-236

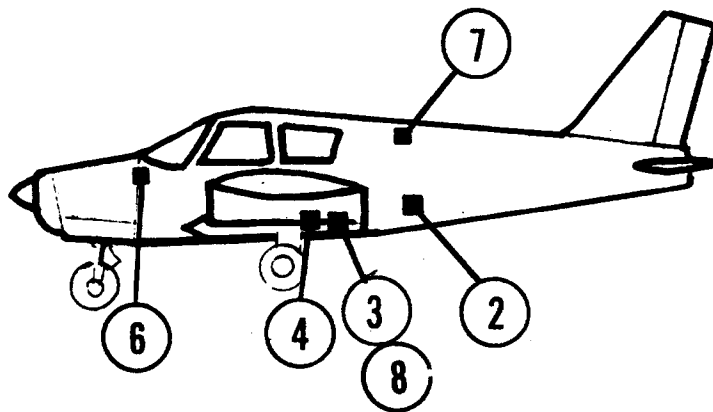
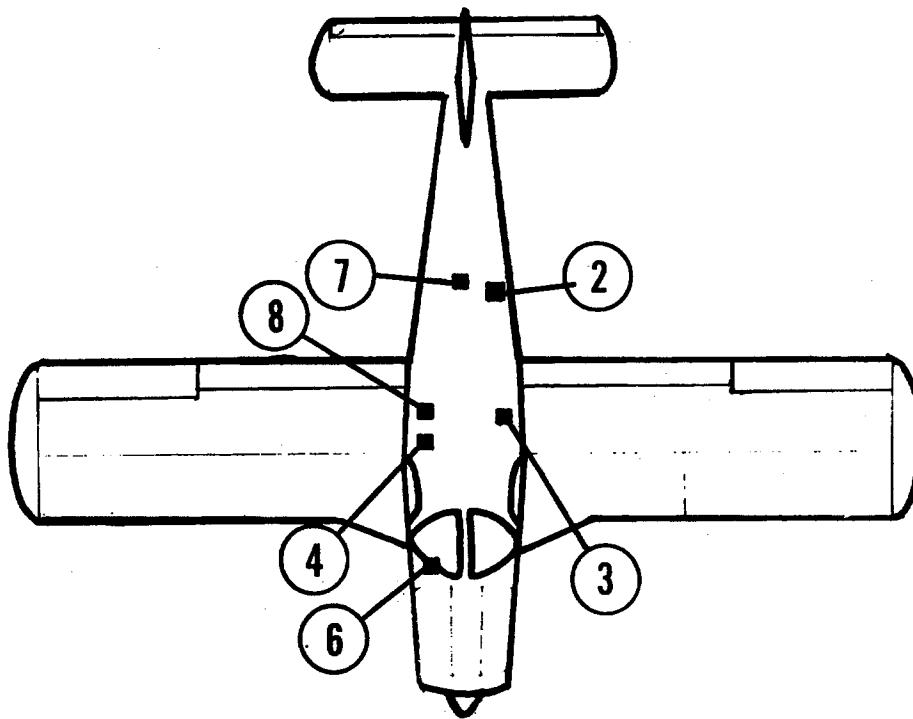

AK217

PIPER CHEROKEE

PA-28-140, PA-150, PA-28-160
PA-28-180

CENTURY III

AK217
STC SA707SW

PIPER PA-28-140, PA-28-150,
PA-28-160 AND PA-28-180

PART DESCRIPTION AND NOMENCLATURE	LOCATION
CONSOLE 1C404	(1) Instrument panel
ARTIFICIAL HORIZON 52D67	(1) Instrument panel
DIRECTIONAL GYRO 52D54	(1) Instrument panel
ROLL SERVO 1C363-183R	(3) Under floor and back ^{rear} seat, pilot's side
PITCH SERVO 1D363-217P	(4) Under floor and rear seat, just aft of main spar, right side
ALTITUDE HOLD 1C407	(6) Behind instrument panel, left side
MAIN CABLE HARNESS 30D207-2	
RELAY BOX 1B405	(10) On roll servo mounting bracket, under floor, and back seat, pilot's side
GYRO-AMPLIFIER 1C359	(9) Under floor and back ^{rear} seat, just aft of main spar, on centerline of A/C
RADIO COUPLER 1C388	(1) Instrument panel
TRIM SERVO 1D360	(7) On bulkhead just aft of baggage compartment at top
TRIM SENSOR 1D310-166	(8) Under floor and rear seat, co-pilot's side
TRIM SWITCH 30B192	Pilot's control wheel
AMPLIFIER 1D395	(2) Aircraft radio rack, left section of aircraft
SWITCH 30A204	Pilot's control wheel

SERVICING DATA

Roll Servo Clutch Setting (lbs): $47 \begin{smallmatrix} +3 \\ -2 \end{smallmatrix}$

Pitch Servo Clutch Setting (lbs): $32 \begin{smallmatrix} +3 \\ -2 \end{smallmatrix}$

Pitch Trim Servo Clutch Setting (lbs): 25+5

Trim Sensor Point Gap (in.): $.010 \pm .002$

Bridle Cable (s): Roll - 30B200 Pitch - 30B270

Limitations Placard Part Number: 13A329-217

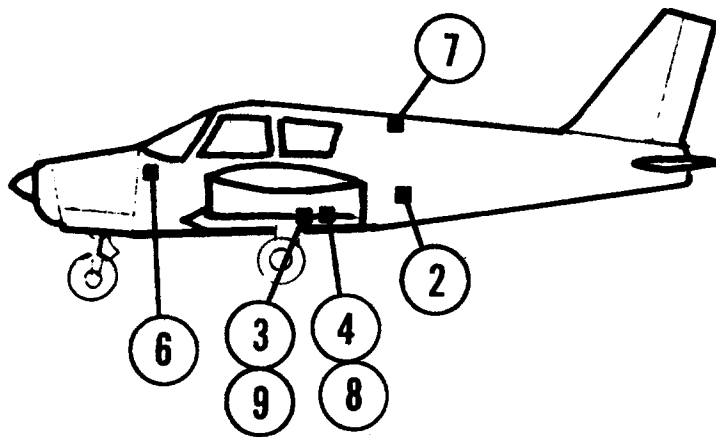
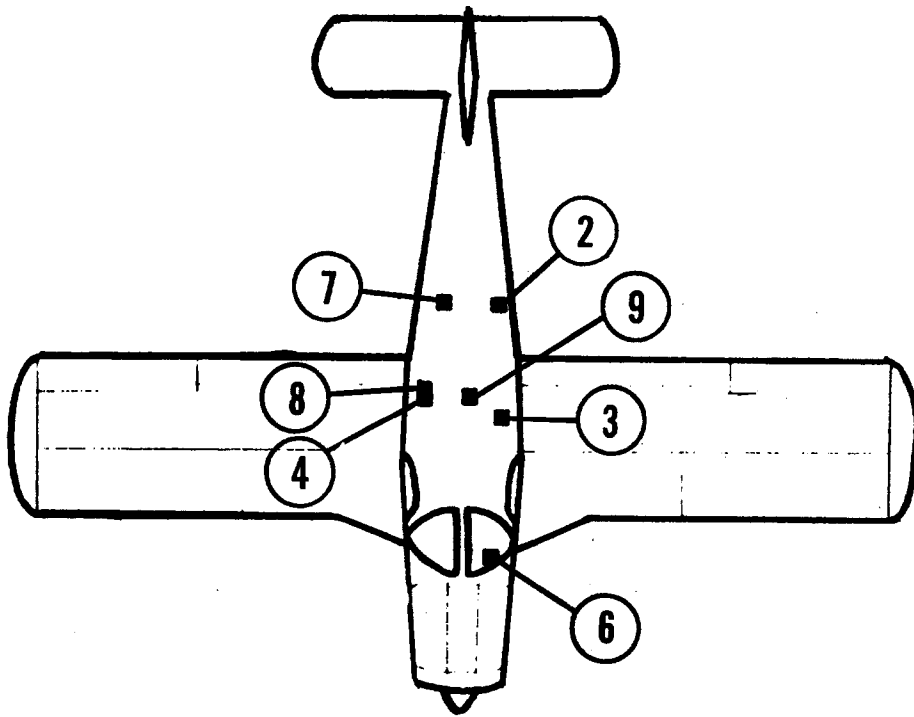

AK253

PIPER CHEROKEE

PA-28-235

CENTURY III

AK253
STC SA822SW

PIPER PA-28-235

PART DESCRIPTION AND NOMENCLATURE	LOCATION
CONSOLE 1C404	(1) Instrument panel
ARTIFICIAL HORIZON 52D67	(1) Instrument panel
DIRECTIONAL GYRO 52D54	(1) Instrument panel
ROLL SERVO 1D363-183R	(3) Under floor and back seat, pilot's side
PITCH SERVO 1D363-217P	(4) Under floor and rear seat, just aft of main spar, right side
ALTITUDE HOLD 1C407	(6) Behind instrument panel left side
MAIN CABLE HARNESS 30D207-2	
RELAY BOX 1B405	(10) On roll servo mounting bracket, under floor and back seat, pilot's side
GYRO-AMPLIFIER 1C359	(9) Under floor and back seat, just aft of main spar. on centerline of A/C
RADIO COUPLER 1C388	(1) Instrument panel
TRIM SERVO 1C500	(7) On bulkhead just aft of baggage compartment at top
TRIM SENSOR 1D310-166	(8) Under floor and rear seat, co-pilot's side
TRIM SWITCH 30B192	Pilot's control wheel
AMPLIFIER 1D395	(2) Aircraft radio rack left section of aircraft
SWITCH 30A204	Pilot's control wheel

SERVICING DATA

Roll Servo Clutch Setting (lbs): $47 \begin{smallmatrix} +3 \\ -2 \end{smallmatrix}$
 Pitch Servo Clutch Setting (lbs): $32 \begin{smallmatrix} +3 \\ -2 \end{smallmatrix}$
 Pitch Trim Servo Clutch Setting (lbs): 25 ± 5
 Trim Sensor Point Gap (in.): $.010 \pm .002$
 Bridle Cable (s): Roll - 30B200 Pitch - 30B200
 Limitations Placard Part Number: 13A329-253

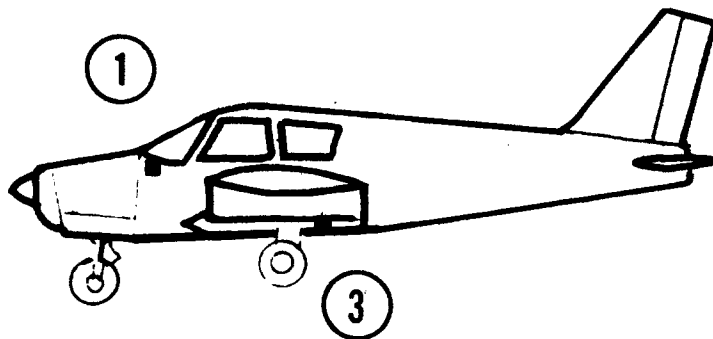
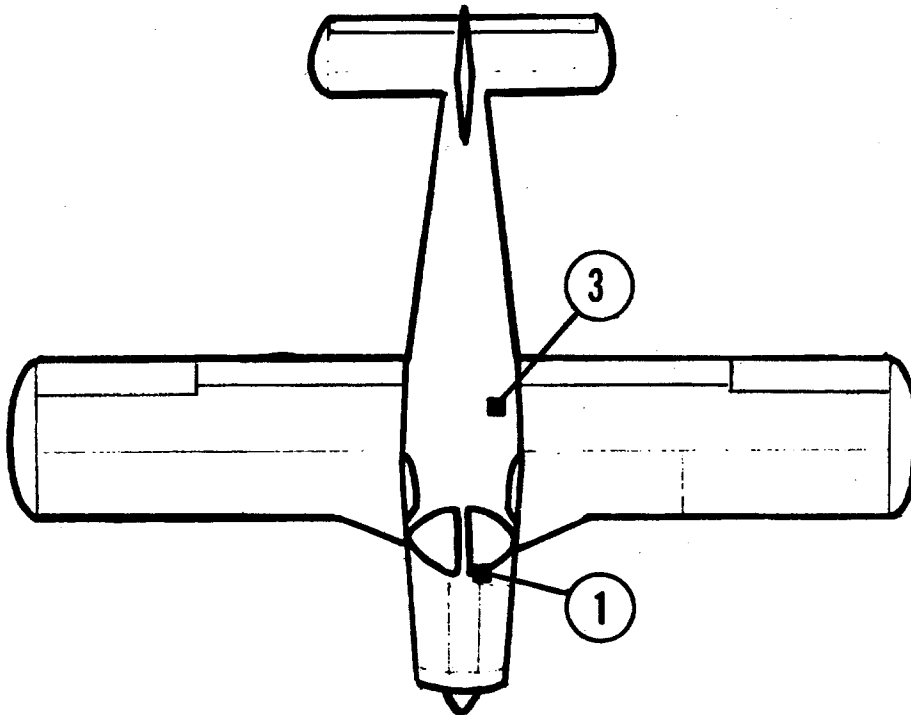

AK234

PIPER CHEROKEE

PA-28-140, PA-28-150
PA-28-160, PA-28-180
PA-28-235, PA-32-260

CENTURY II

AK234
STC SA757SW

PIPER PA-28-140, PA28-150, PA28-160,
PA-28-180, PA-28-235 and PA-32-260

PART DESCRIPTION AND NOMENCLATURE	LOCATION
CONSOLE-AMPLIFIER 1C385	(1) Instrument panel
ARTIFICIAL HORIZON 52D66	(1) Instrument panel
DIRECTIONAL GYRO 52D54	(1) Instrument panel
ROLL SERVO 1D363-183R	(3) Under floor and rear seat, pilot's side
MAIN CABLE HARNESS 30C198	
RADIO COUPLER (OPT.) 1C388	(1) Instrument panel

SERVICING DATA:

Roll Servo Clutch Setting (lbs): $47 \begin{matrix} +3 \\ -2 \end{matrix}$

Pitch Servo Clutch Setting (lbs):

Pitch Trim Servo Clutch Setting (lbs):

Trim Sensor Point Gap (in.):

Bridle Cable (s): Roll - 30B200

Limitations Placard Part Number: 13A344-234

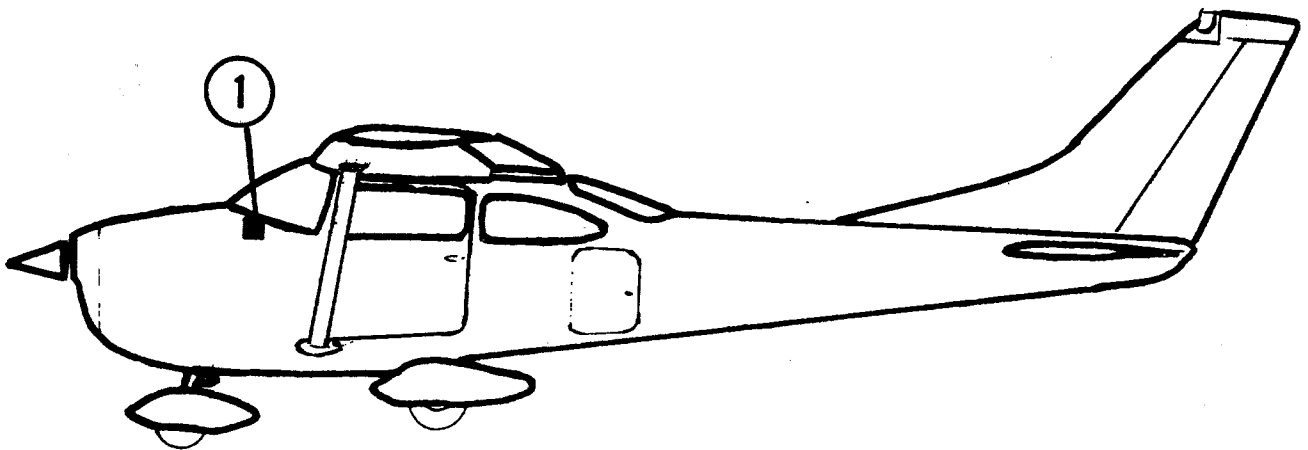
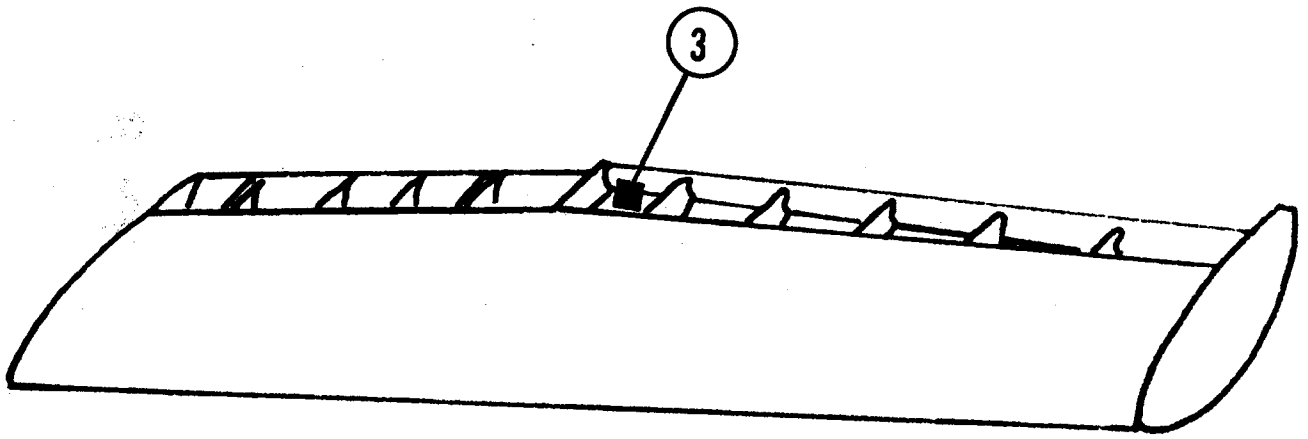

AK243

WREN

460H, 460J, 460K

CENTURY II

AK243
STC SA791SW

WREN 460H, 460J AND 460K
CESSNA 182F, 182G, 182H, 182J
AND 182K

PART DESCRIPTION AND NOMENCLATURE	LOCATION
CONSOLE-AMPLIFIER 1C385	(1) Instrument panel
ARTIFICIAL HORIZON 52D66	(1) Instrument panel
DIRECTIONAL GYRO 52D54	(1) Instrument panel
ROLL SERVO 1D363-243R	(3) In left wing 105 inches outboard from fuselage at existing inspection hole aft of rear spar
MAIN CABLE HARNESS 30C198	
RADIO COUPLER (OPT.) 1C388	(1) Instrument panel
NOTE: ROLL SIGNAL FILTER 1B440	(1) Under instrument panel near artificial horizon

SERVICING DATA

Roll Servo Clutch Setting (lbs): 45 ± 5
 Pitch Servo Clutch Setting (lbs):
 Pitch Trim Servo Clutch Setting (lbs):
 Trim Sensor Point Gap (in.):
 Bridle Cable (s): Roll - 30B242
 Limitations Placard Part Number: 13A344-243

SECTION III TEST EQUIPMENT IN-AIRCRAFT TROUBLESHOOTING

3.0 GENERAL

This section is designed as a guide in troubleshooting the Century II and III autopilots within the aircraft. It is basically divided into three sub-sections: Test Equipment, Troubleshooting the Century II and Troubleshooting the Century III.

Each of the sub-sections on troubleshooting are divided into two levels or degrees of troubleshooting. First is quick checks. This consists of general operational checks such as turning the autopilot on and confirming servo engagement through visual observation of the control surfaces as the Roll or Pitch Command Knobs are turned. The object is to search for the obvious area of difficulty before proceeding with detailed tests.

The second level of testing in-aircraft tests requires use of the 66D141 Test Set. Through use of the quick checks it should have been possible to determine the probable trouble area within the autopilot system. Additional tests through use of the Test Set should narrow down the specific unit within the autopilot system which has malfunctioned.

Although the Century II and III autopilots are "Open Loop" systems (systems requiring the dynamics of the aircraft in flight), most troubleshooting can be performed under static conditions on the ground. This is made possible by use of the 66D141 Test Set described in the following paragraphs. Please note that the following (3.1 Test Equipment) is strictly a description of the equipment and does not contain operational procedures. Therefore, if you are familiar with the 66D141 Test Set, proceed to paragraph 3.2.

3.1 66D141 TEST SET

The 66D141 Test Set (Fig. 3-1) is designed to facilitate testing of the Century II and Century III autopilot systems on a substitution basis. Provisions are made to substitute into an operating system any major component except the amplifier in the Century III and the console amplifier in the Century II.

The Test Set consists of four major sections plus necessary connecting cables. These sections are as follows:

A. 66D141-1 Gyro Substitute [Fig. 3-1(a)] - With this section both the D.G. and Artificial Horizon can be replaced (simultaneously) with substitute signal sources. The D.G. signal is variable in steps to provide outputs corresponding to 0, ± 10 , and ± 45 degrees of deviation from the selected headings. The zero position is used to provide an accurate zero signal so that the roll centering adjustment can be accurately set or checked for range of control. The 10° outputs are used to check the heading sensitivity of the amplifier command channel and by means of comparison to determine whether or not the D.G. in question provides a signal usable for operation within the system. The 45° outputs are provided primarily for the purpose of checking Radio Coupler intercept angles.

B. 66D141-2 Power Section [Fig. 3-1(b)] - With this equipment, amplifier output and servo performance of either axis can be observed. Two connectors are provided so the cable to either servo can be intercepted. A pilot light is provided to indicate the presence of solenoid voltage. A voltmeter is provided to monitor the signal actually being applied to the servo motor. A selector switch is provided so that (1) normal operation (amplifier drive into the servo load) can be ob-

served, (2) amplifier drive into a dummy load can be observed and (3) bi-directional drive directly from the aircraft electrical system can be applied to the servo. To make possible operation with 14 or 28 volt supplies, a selector switch is provided.

C. 66D141-3 Console Substitute [Fig. 3-1(c)] - Electrically this console is interchangeable with the standard autopilot console for test purposes. Using the substitute console it is possible to determine rapidly if the combination of signal sources and amplifier can be brought within usable limits by means of the adjustments provided on the standard console. Also, it serves as a substitute to aid in determining whether or not the installed console or altitude hold is defective.

D. 66D141-4 Radio Coupler Tester [Fig. 3-1(d)] - The Coupler Tester contains a simulated radio signal source and intercepts the coupler output to provide direct monitoring of coupler performance. When used with the 66D141-1 Gyro Substitute described in the previous section and with an autopilot amplifier as a source of power a complete static testing of coupler performance is possible.

E. Test Cables - With the 66D141 Test Kit, a complete complement of cables is furnished. The cabling will allow units of the Test Kit to be "plugged into" the autopilot at various points to quickly determine the operational status of the questioned component. Furnished with each Test Kit are:

1. 30C198 Cable Harness, Century II.
2. 30A266 Radio Coupler Extension Cable.
3. 30A265 D.G. Extensions (2).
4. 30A211-36RP Servo Extensions (2).
5. 30A367 Console Extension (CD-20).
6. 30C207-5 Cable Harness, Century III.
7. 30B271 Test Lead Assembly
8. 30A226-1 CD-34 Extension. (Male to female).

3.2 CENTURY II TROUBLESHOOTING

3.2.1 Quick Checks - Fig. 3-2 is a troubleshooting logic chart which is designed to help locate a defective unit or isolate a problem area. The chart provides rapid troubleshooting of the autopilot system without necessitating disassembly of the system or aircraft. When additional troubleshooting becomes necessary, consult paragraph 3.2.2. Additional references to this paragraph are also noted in the troubleshooting chart.

Insight as to where a problem exists in the system can be obtained through in-flight checks or comments from the pilot. Listed below are a few problems which can occur but are easily cured through flight adjustments. Therefore, before troubleshooting the system, be sure the following checks and adjustments have been made. (Reference Section VI Ground Checks and Flight Adjustments, if necessary.)

Wing rock - This is a condition where the aircraft tends to oscillate or rock back and forth in smooth air. In the Century IIB, wing rock can normally be corrected with the roll threshold adjustment. See Section VI, paragraph 6.3 for adjustment procedure. Wing rock may also be caused by a loose bridle cable on the servo or incorrectly adjusted roll signal filter (1B440).

Incorrect Bank Limit - In the Roll mode the Century II should allow a maximum roll bank or 30° when the Roll Command is rotated full left or right. In the HDG mode the maximum bank angles are 20° . Consult Section VI of this manual for bank limit adjustments.

Roll Centering - If the aircraft fails to maintain a selected heading ($\pm 2^{\circ}$), a roll centering adjustment may be required. Consult Section VI, paragraph 6.3.2 or 6.3.3.

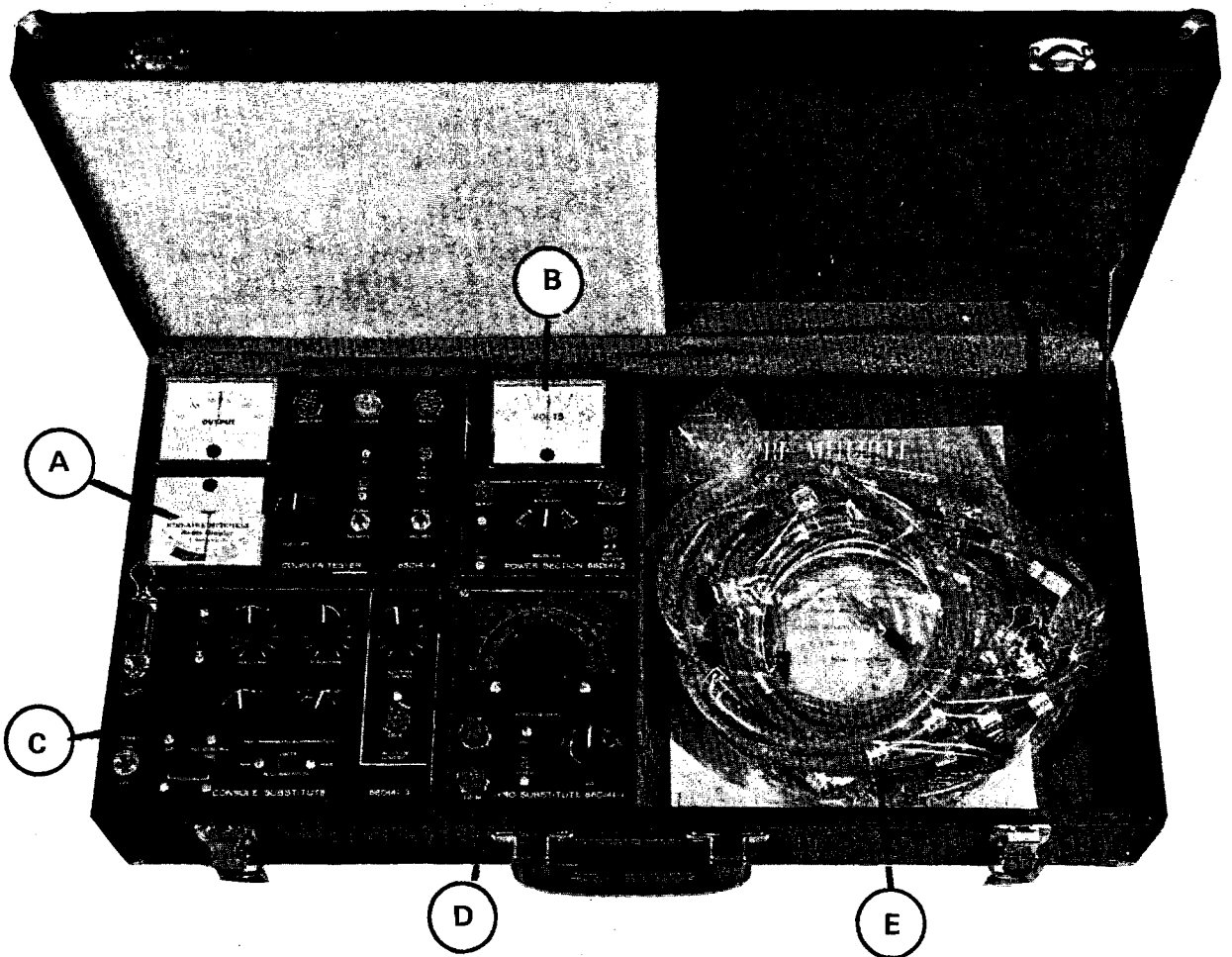

- A 66D141-4 RADIO COUPLER TESTER
- B 66D141-2 POWER SECTION
- C 66D141-3 CONSOLE SUBSTITUTE
- D 66D141-1 GYRO SUBSTITUTE
- E TEST CABLE SET

FIGURE 3-1

66D141 TEST SET

Intercept Angles

(Radio Coupler Option)-When the Century^o II contains the optional Radio Coupler an additional adjustment of intercept angles may be required. Normally the Radio Coupler will provide a 45^o intercept angle to a selected radial whenever the Omni needle is at full scale deflection. Anything less than full scale deflection will cause a proportionally smaller intercept angle. See Section VI, paragraph 6.3.3 for adjustment procedures.

- 3.2.2 Checking the Century II Console Amplifier 1C385 With the 66D141 Test Set - The 66D141 Test Set does not provide a substitute for the 1C385 Console Amplifier. Therefore, troubleshooting of this unit is basically a process of elimination. First, in this process, is checking for A+ to the Console Amplifier.

NOTE: When wiring checks are called for, see Fig. 3-3 for system inter-connect diagram.

A. Checking for A+

1. Disconnect the large 15 pin connector from the rear of the Console Amplifier.
2. Switch on aircraft master power. Check Century II circuit breaker is pushed in.
3. Read aircraft voltage from pin "N" on connector to ground.
4. If zero, check wiring and circuit breaker.
5. If OK, remove Century II Console Amplifier from instrument panel. Locate red wire leading to rear of ON-OFF toggle switch (Century II) or push button (Century IIB). This is the A+ lead from the printed circuit board plug. Plug the connector into the Console Amplifier and read A+ from rear of switch (red wire) to ground.
6. If zero, defective Console Amplifier internal harness.
7. If OK, switch Century II console on. Read A+ through switch on terminal with blue wire. If zero, defective switch.
8. If OK, but system appears dead, perform Console Amplifier output checks.

B. Checking Console Amplifier Output

1. Disconnect CD-47 behind the Console Amplifier. CD-47 is the short section of cable branching out from the main cable harness at the Console Amplifier plug.
2. Connect the male CD-47 to the amplifier receptacle on 66D141-2 Power Section. Connect the female connector to the servo plug. Set the selector knob on the Power Section to AMPL-RES and voltage to match aircraft voltage.
3. Switch the Century II on.
4. The Solenoid lamp on the 66D141-2 Power Section should light. If not, check continuity from pin "A" on male CD-47 plug to pin "M" on the main connector to the Console Amplifier. If OK, defective Console Amplifier. See Fig. 3-3 for wiring diagram.
5. Rotate the Roll Command Knob left and right and observe Power Section meter. Reading should range from left 11 volts to right 11 volts. If the Artificial Horizon is tilted beyond 30^o (45^o for example), the meter will read 11 volts in the direction op-

**QUICK CHECKS
CENTURY II TROUBLESHOOTING LOGIC CHART**

FIGURE 3-2

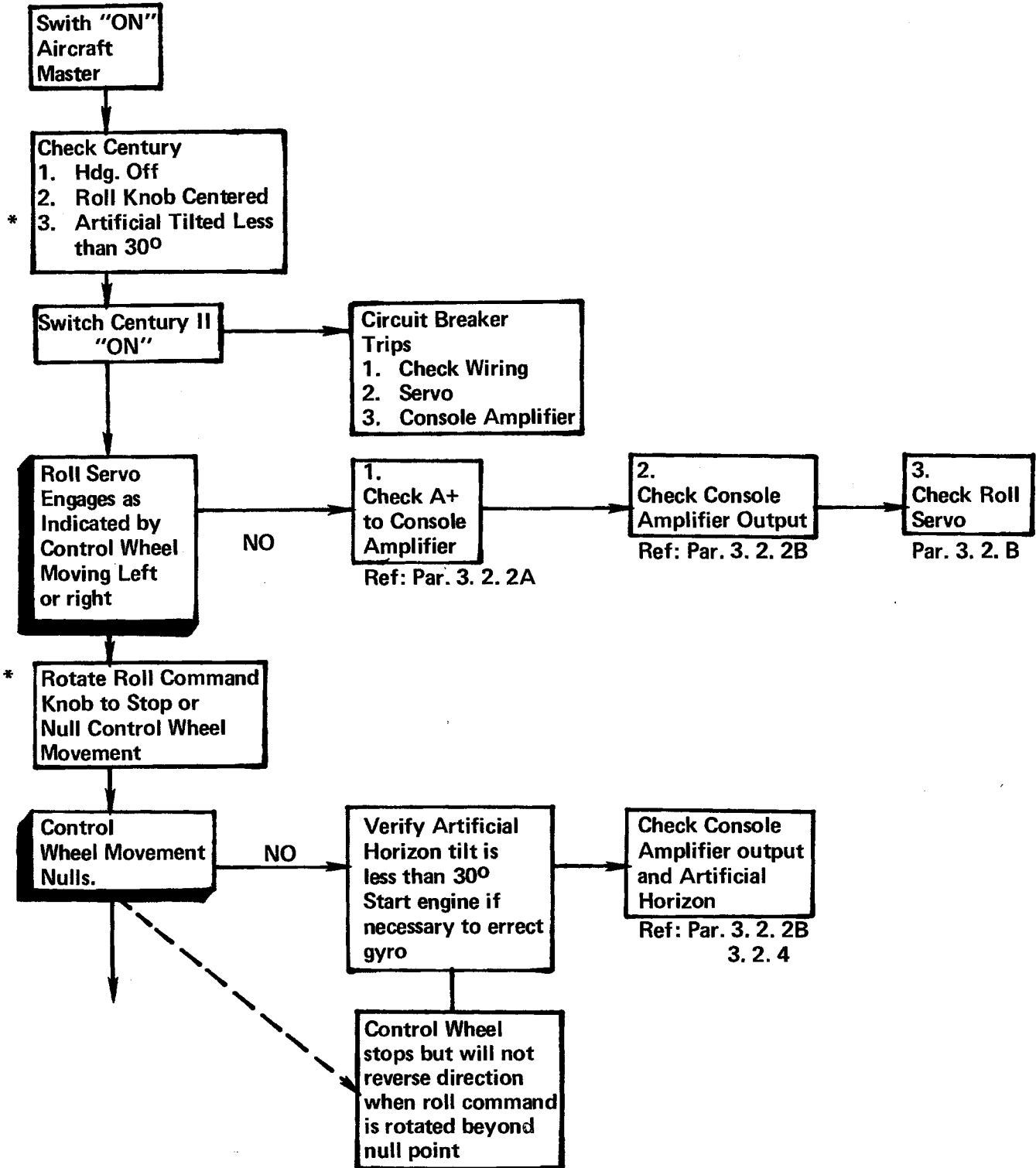

* In the roll mode the roll command knob provides the equivalent of 30° left or right bank command to the system. If the artificial horizon is tilted more than 30° during ground checks it will be impossible to null control wheel movement whenever the Century II is switched on. NOTE: Some tilt in the artificial horizon may be helpful in determining proper operation of the system. For example if the horizon indicated 20° right bank the roll command knob, will need to be rotated nearly full right to obtain a null. This indicates the presence of both a horizon and command signal.

HDG Mode Checks

Switch Century II to Hdg. If Radio Coupler installed switch to Hdg. also

On D. G. Rotate course selector to null Control Wheel.

It may be necessary to start aircraft engine if artificial horizon tilt is greater than 20°. If the horizon tilt is greater than 20° the control wheel will continuously try to move in the opposite direction of the heading command

Control Wheel Nulls

NO

1. Possible defective Hdg. Switch. If rotation of roll command knob stops wheel movement, replace Hdg. switch or control amp.

2. Possible wiring or D. G. problem, Refer to par. 3. 2. 5

3. Possible Radio Coupler (if installed) problem see Par. 3. 2. 6

Radio Coupler Checks

Tune aircraft radio to local VOR and obtain center needle on omni bearing indicator

It is necessary that the artificial horizon be level for the following checks. Therefore start aircraft engines if not level.

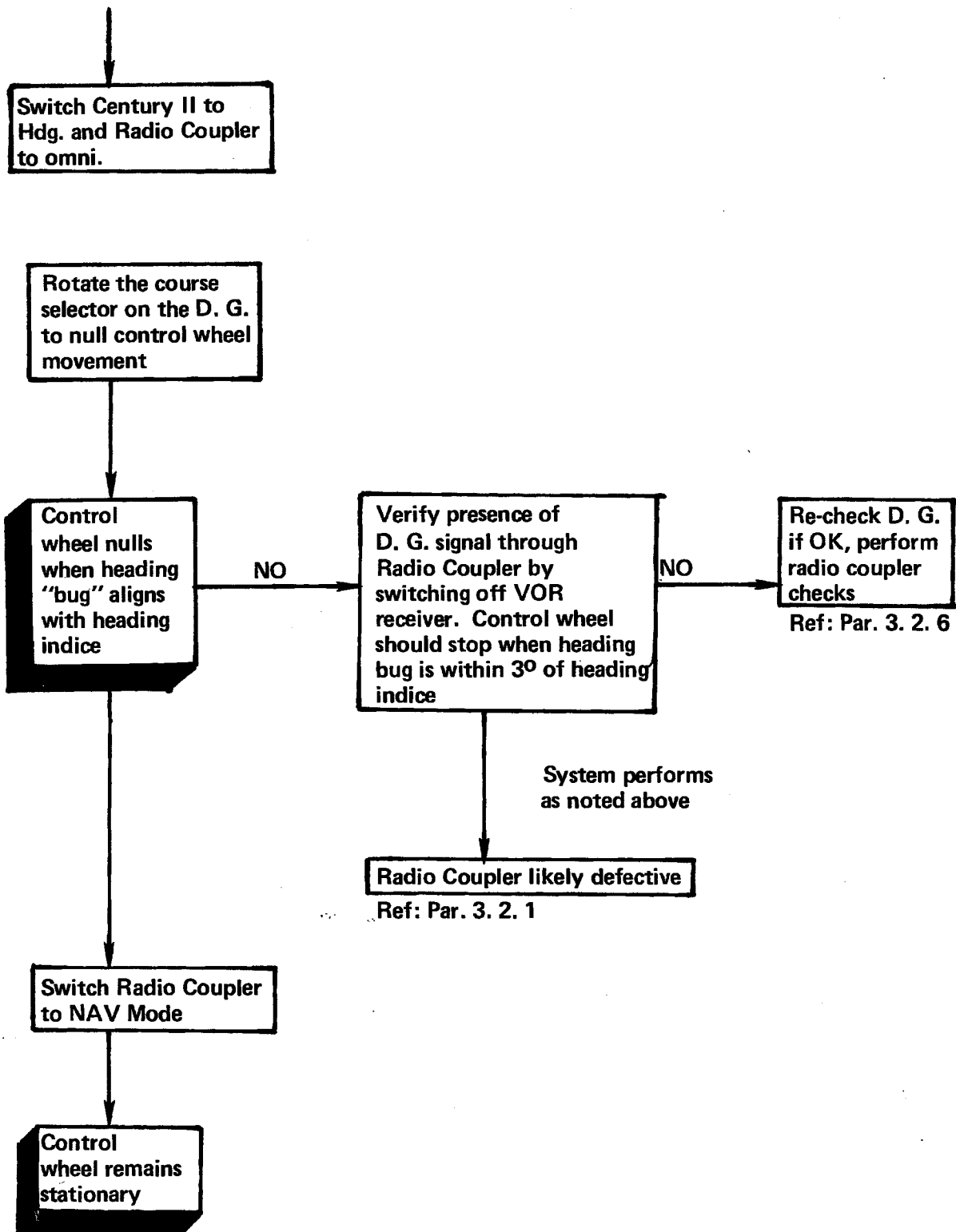

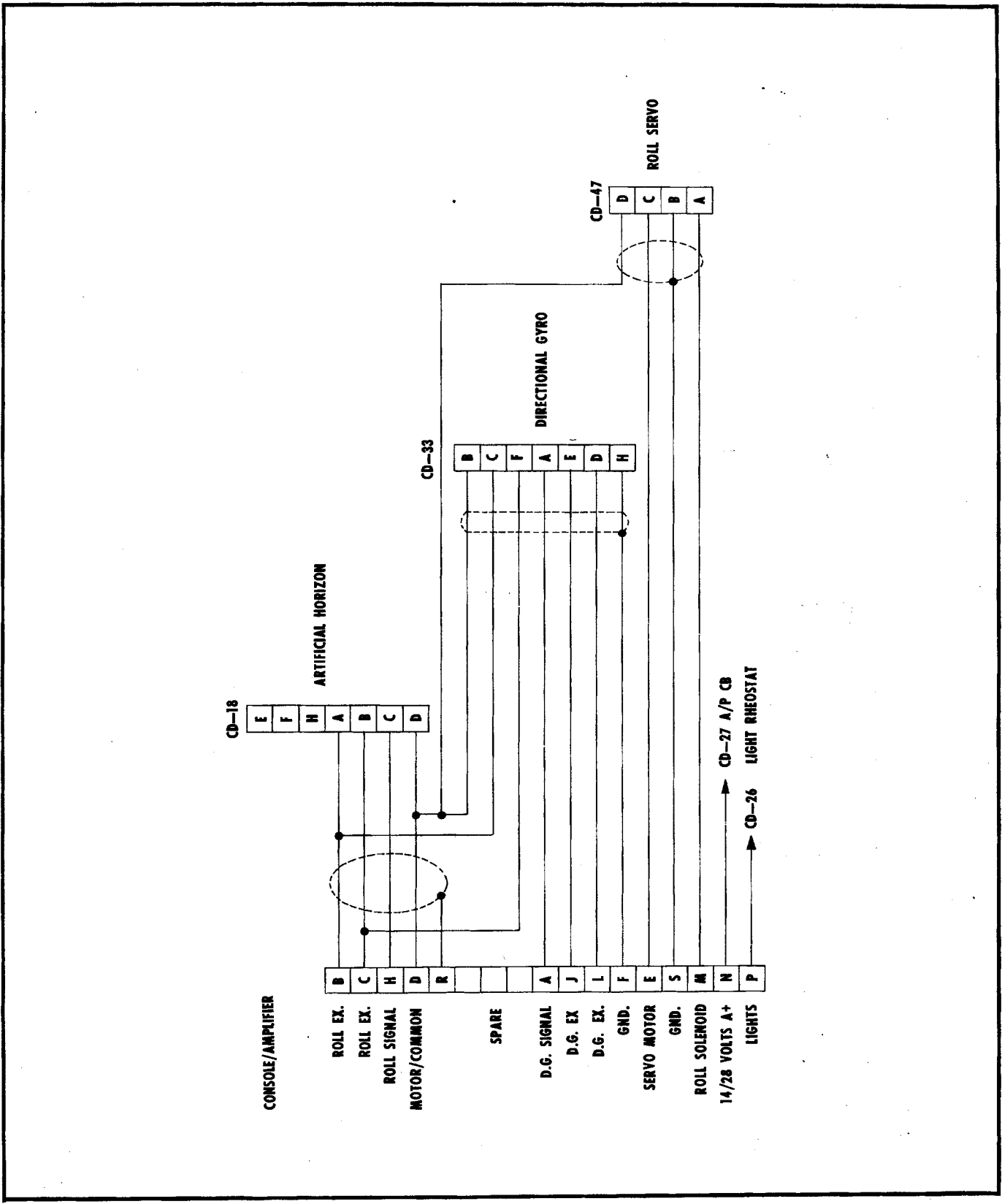

FIGURE 3-3
CENTURY II
INTERCONNECT WIRING DIAGRAM

posite of the indicated horizon bank. If the horizon is tilted at 30°, the meter will indicate approximately zero when the Roll Command Knob is rotated to its limit in the direction of indicated bank. This characteristic illustrates the fact that the Roll Command Knob is capable of commanding 30° banks. Failure of the system to respond in this manner normally indicates a defective horizon, roll signal filter (if used) or faulty wiring.

6. If the output of the Console Amplifier is zero in all of the conditions outlined in step 5 above a continuity check from CD-47 to the Console Amplifier receptacle should be made. Check as follows:

<u>CD-47</u>	to	<u>Console Amplifier Receptacle</u>
Pin B		Pin S
Pin C		Pin E
Pin D		Pin D

7. If readings in step 5 range from 11 volts left to 11 volts right when the Roll Command Knob is rotated full left to full right and zero when the Roll Command Knob is centered even though the Artificial Horizon is tilted beyond 30°, a defective Artificial Horizon is indicated. Check continuity from CD-18 (rear of horizon) to Console Amplifier receptacle. Also see Section 3.2.4 Artificial Horizon Test.
8. Press HDG switch on Console Amplifier "ON" and verify by observing Power Section meter that rotation of Roll Command Knob on console has no affect on output.
9. If output is affected, the HDG switch on the Console Amplifier is defective.
10. Rotate the Course Selector on the Directional Gyro (D.G.) so that the heading "bug" is aligned with the heading index. This will produce zero output as indicated on the Power Section provided the Artificial Horizon is level. A tilt in the Artificial Horizon will cause the output to vary in a similar manner as outlined in step 5. In the HDG mode the Course Selector has command authority up to 20° bank. This means that if the Artificial Horizon is tilted beyond 20°, it will be impossible to null or zero the Console Amplifier output. Remember in the Roll mode (Roll Command Knob), roll authority was 30°.
11. If, in step 10, rotation of the Course Selector has no affect on the output, the system may have a defective Directional Gyro, wiring or Radio Coupler (if installed). See paragraph 3.2.6 for Radio Coupler Checks.
12. Switch the Century II "OFF". Disconnect the 66D141-2 Power Section and re-connect CD-47.

3.2.3 Checking the Roll Servo

1. Disconnect CD-47 at the roll servo. Connect the male CD-47 to the amplifier receptacle on the 66D141-2 Power Section. Connect the Servo extension cable (30A211-36R) supplied with the 66D141 Test Set between the roll servo and the servo plug on the Power Section.
2. Set the 66D141-2 Power Section to AMPL-MTR.
3. Switch the Century II "ON". The roll servo should engage. If not, check for solenoid voltage by observing Solenoid light on 66D141-2 Power Section. If lamp is not illumi-

nated check continuity from servo cable CD-47 back to Console Amplifier plug (Pin A of CD-47 to Pin M on Console Amplifier plug). If lamp is illuminated the problem is in the roll servo solenoid. This can be verified by checking Pin A of CD-47 on the servo to ground with an ohmmeter. Resistance should be less than 400 ohms but not less than 30 ohms on 14 VDC systems. Infinity would indicate an open solenoid. Zero ohms indicates a short which would be apparent as soon as the Century II system is switched on (the circuit breaker will trip).

Some other problems which could occur are mechanical. For example, electrically, the solenoid could be operating properly. However, due to dirt, age, etc., the solenoid could stick and therefore not engage the servo. On the older systems (Mitchell servo), this can be easily seen since the servo and solenoid mechanism are not covered. In the newer systems, using globe servos, the black, plastic case must be removed for examination purposes.

4. If the servo engages but the roll servo fails to run the problem is in one of three places: the Console Amplifier - See Test 3.2.2, Checking Console Amplifier Output; the wiring-check wiring; or the roll servo. The roll servo may be checked by connecting the 66D141-2 Power Section as described in step 1. Switch the Century II "ON" and set the selector on Power Section to "OFF". The solenoid lamp should be illuminated. Switch the selector to BAT. R-UP. The servo should drive the ailerons right. Switching to BAT. L-DN should drive the ailerons left. If the servo fail to operate, it is defective and must be replaced.

3.2.4 Checking the Artificial Horizon

1. Loss of the roll reference signal from the Artificial Horizon will immediately be noted by the pilot. In the roll mode full rotation of the Roll Command Knob causes the aircraft to roll in the direction of command and establish and maintain a 30° bank angle. However, without a roll reference signal the command would cause the aircraft to continue rolling until it was upside-down if the pilot did not stop it.

Basically, the aircraft could still be flown with only the Roll Command Knob but it would require continuous manipulation since returning the Roll Command Knob to the center position would not return the aircraft's ailerons to neutral. Remember, the Century II autopilot is an open loop system. The only reference the autopilot has as to the position of the aircraft's controls is the attitude in which the aircraft is flying.

Loss of the Artificial Horizon roll reference signal can be narrowed down to four causes: defective Artificial Horizon; defective wiring (CD-18 to amplifier); defective Console Amplifier; or a defective Roll Signal Filter.

2. The Roll Signal Filter can be checked by simply disconnecting it from the system and reconnecting CD-18 directly to the Artificial Horizon. Perform the Quick Checks in Fig. 3-2. If system now responds correctly, Roll Signal Filter defective.
3. Check pins A, B, C and D of CD-18 to pins B, C, H and D respectively on the Console Amplifier plug for continuity. See Fig. 3-3 for wiring diagram.
4. If wiring is OK, check operation of Console Amplifier by connecting the 66D141-1 gyro substitute to the system. Disconnect CD-18 from the Artificial Horizon and connect it to the CD-18 plug on the gyro substitute. Set the gyro substitute vernier dial to 0 degrees and the slide switch to Roll.

5. Switch the Century II on and verify it is in the Roll mode. Center the Roll Command Knob to stop aircraft control wheel movement.
6. Rotate the gyro substitute vernier to 15° left (LT). The control wheel will instantly start moving to the left. Rotate the Roll Command Knob to the left to stop wheel movement. Repeat to the right.
7. If, in Steps 5 and 6, the system fails to respond as noted, the Console Amplifier is defective.
8. Additional checks on the Console Amplifier may be made using the gyro substitute. For example, checking the bank limits is accomplished by setting the gyro substitute to 30° left. Rotate the Roll Command Knob on the Console Amplifier to the left until the control wheel movement is nulled. If the roll bank limits are set properly wheel movement will stop when the Roll Command Knob is near or at its mechanical limit. This is just a general check on the bank limit function. Detailed adjustment procedures are contained in Section VI.

Checks to the right are made in the same manner.

9. At this point wiring and operation of the Console Amplifier have been checked using the gyro substitute. Additional verification that the Artificial Horizon is defective can be determined by bench testing.

3.2.5 Checking the Directional Gyro

1. The Directional Gyro supplies heading information to the system via CD-33. Loss of this signal will result in the system's failure to respond to heading commands.

Assume that the Century II, being in the HDG mode, suddenly lost the heading signal from the D.G. The aircraft would slowly drift off heading. The pilot would not realize the loss signal until he noted the heading drift or attempted to select a new heading. If he attempts to select a new heading he will find that rotation of the course selector will have no effect on the aircraft heading.

2. To eliminate the Radio Coupler remove from system and reconnect CD-33 from main cable harness directly to D.G. Perform Quick Checks.
3. Check wiring (without Radio Coupler) by performing continuity checks from CD-33 to the Console Amplifier plug. Check as follows:

CD-33	to	Console Amplifier
Pin A		Pin A
Pin B		Pin D
Pin C		Pin B
Pin D		Pin L
Pin E		Pin J
Pin F		Pin C
Pin H		Pin F

4. With system using a Radio Coupler, continuity checks should be made first with the Radio Coupler removed as indicated in Step 3. If OK, perform checks with Radio Coupler installed. Place Radio Coupler in HDG mode. Check from CD-33 (short lead from Radio Coupler) to Console Amplifier. Check as follows:

CD-33	to	Console Amplifier
Pin A		Pin A
Pin B		Pin D
Pin D		Pin L
Pin E		Pin J
Pin H		Pin F

5. Illumination of the wiring and Radio Coupler indicates that the D.G. is defective. To confirm, disconnect CD-18 from rear of the Artificial Horizon and connect to CD-18 on the 66D141-1 gyro substitute. Set the vernier knob on the 66D141-1 to 10° left roll and the slide switch to Roll.
6. Set the Directional Gyro so that the heading "bug" is 10° to the left of the heading index (10° off heading). Switch the Century II on and place in the HDG mode.

If the D.G. is functioning properly the control wheel movement will be slow. With small manipulation of the course selector knob on the D.G. it should be possible to stop control wheel movement completely. At this point the D.G. heading offset should be 10° ± 2°.

Repeat to the right.

7. If the system failed to respond as stated in Step 6, the D.G. is likely defective. An additional check should be made to ascertain that the Roll Excitation signal from the Console Amplifier is being generated. To check, disconnect CD-33 from rear of D.G. and connect to CD-33 on the 66D141-1 gyro substitute (leave connectors and settings called out in Steps 5 and 6).

Set the D.G. selector on the gyro substitute to 10° left and note control wheel stops. It may be necessary to adjust the Attitude Gyro vernier slightly to completely stop control wheel movement. If the system fails to respond in the manner described, re-check wiring. If the wiring checks and other portions of the system operate properly, the Console Amplifier is likely defective, not the D.G. In some cases the HDG switch will not engage or is defective. In this instance the Roll Command Knob will still have affect even though the HDG button is pressed. Or, both the HDG and Roll modes will open in which case only the attitude reference signal from the horizon will be present.

3.2.6 Checking the Radio Coupler

1. For the following checks the gyro substitute (66D141-1) should be connected in place of the Artificial Horizon as shown in Fig. 3-5. Set the roll vernier to 0° and the pitch/roll switch to roll.
2. To check the heading circuitry:
 - a. Install servo test box 66D141-2 in line with servo (See Fig. 3-5). Set voltage switch to the appropriate voltage and selector to AMPL-RES position.
 - b. Switch Radio Coupler to HDG mode and null the power section meter out with the course selector knob on the Directional Gyro. Turn NAV Radio off.
3. Switch the Radio Coupler to OMNI mode and note servometer stays nulled ± 3V. Any deviation would indicate a malfunction in the heading or omni circuitry and would warrant removal for repairs or internal alignment.

4. To check the crosswind circuits displace the heading bug 5° to the left. Note that within 2 minutes the output indicated on the servo meter drops to 3 Volts or less. Repeat the test to the right. If the output fails to decrease there is a problem in the crosswind circuitry. The coupler should be removed for repair.
5.
 - a. The radio circuitry tests require stable radio information from a V. O. T. or close omni station. If none is available connect a CD-34 extension cable from CD-34 on the Radio Coupler to CD-34 on Coupler Tester Box 66D141-4 (See Fig. 3-5).
 - b. Center the needle on either the Coupler Tester or the OBI. Center the heading bug on the D.G. The power meter should show a null $\pm 3V$.

Remember the rate circuitry may cause the output to slowly decrease to a null. If the output stays greater than $\pm 3V$ with everything centered, there is a problem in the radio circuitry which should be corrected.

- c. With the Coupler Tester Box or the OBI, dial a full scale needle deflection (100%) to the right. The power meter will show a full output in the same direction. Cancel the output by moving the heading bug on the D.G. to the left. The heading bug should be off center 40° to 50° to the left. This is the intercept angle the autopilot will establish when intercepting a radial. You should obtain the same angle by moving the radio needle to the left full scale and the heading bug to the left.

If the intercept angles are not within the tolerance they should be adjusted in flight to 45° with the adjustment pots on the side of the Radio Coupler. See Section VI, Paragraph 6.3.3 for adjustment procedure

- d. Any wiring problem that would show up in the radio checks can be eliminated by using the Coupler Tester Box. If you used the substitution box to check the Radio Coupler, re-connect it to the aircraft harness and see that the autopilot follows radio signals.

If the autopilot does not react to aircraft radio signals, check the wiring from CD-34 to the aircraft radio converter as follows:

CD-34		
Pin A	Radio + right	SEE NOTE
Pin B	Radio + left	

NOTE: Check radio manuals for pin numbers.

If the wiring to the radio converter is good have the converter checked.

This completes the radio coupler ground checks.

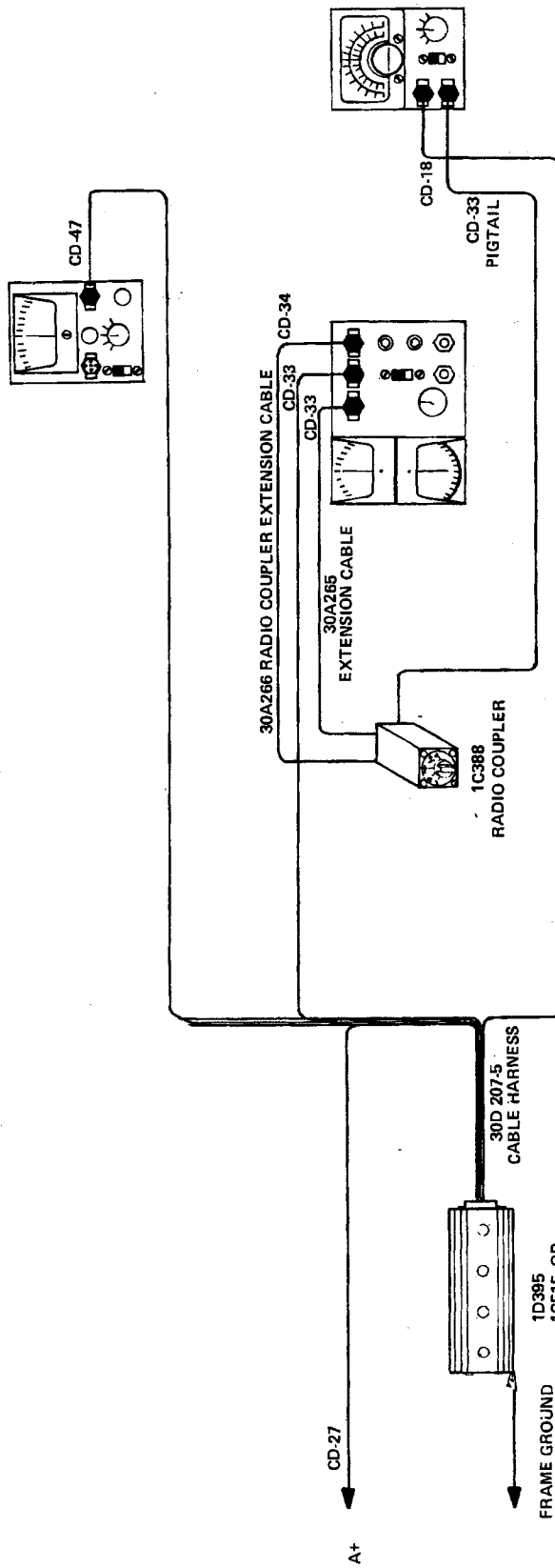

FIGURE 3-5

3.3 CENTURY III TROUBLESHOOTING

3.3.1 Quick Check - Fig. 3-6 is the troubleshooting logic chart for the Century III autopilot. As with the Century II chart the most basic requirements for autopilot operation are checked first. The more advanced modes such as the Omni mode are checked after Roll and Heading Mode.

When any check in the troubleshooting chart fails, consult the unit checkout procedure to isolate the defective component. In most cases the logic chart will be referenced to a portion of the unit check out procedures to assist you in locating a defective component.

3.3.2 General - Troubleshooting of the Century III is basically divided into two parts: Roll Checks and Pitch checks. This is done to simplify the following procedures. Also, it is a logical division since the Century III's electronics are such that the roll and pitch sections operate independently and therefore, can fail independently.

This portion of troubleshooting is designed as a follow-up to the quick check logic chart (Fig. 3-6). It will outline use of the 66D141 Test Set as a means of substituting various components of the system to locate the defective component. Set up procedures for the 66D141 test equipment are called out as the need arises. General information on how the Test Set is connected to the system is illustrated in Figures 3-9 through 3-12.

3.3.3 Century III A+ Checks - Check A+ to the console and from the console to the amplifier whenever the system appears to be dead. In a situation where the ROLL button will not engage and hold, it is likely the aircraft voltage is not reaching the console. In this case check as follows:

1. Check for aircraft voltage across protected side of autopilot circuit breaker.
2. Disconnect CD-20 from rear of console and check for A+ from pin 1 of CD-20 to airframe ground. (Complete wiring schematic is shown in Fig. 3-7.)
3. If A+ is reaching the console but not the amplifier all of the mode selectors will engage when pressed. However, rotation of the ROLL command or pitch command knobs will be ineffective since the roll and pitch servos will not engage. The point to remember is that the console will operate when the amplifier is disconnected, or in the case of a wiring problem, or open A+ line between the console and amplifier.
4. Check A+ to the amplifier by disconnecting the amplifier plug.
5. Switch on aircraft master power and press "ROLL" on the console.
6. Check for A+ between airframe ground and pin N in the amplifier plug.

3.3.4 Roll Section Checks - The following tests check operation of the Century III in the lateral modes (ROLL and HDG). These tests use components of the 66D141 Test Set as a means of substituting components of the system whenever a problem becomes apparent.

Before beginning with Step 1, check position of the Artificial Horizon. It should not be tumbled beyond 20° in roll and 5° in pitch. If the horizon is tilted beyond these limits it will be necessary to start aircraft engine(s) and erect the gyro. In many cases after the engine is switched off the gyro will run down and remain within the correct position provided the aircraft is not moved.

1. Turn on aircraft master switch and center the roll and pitch knobs.
2. Push Roll rocker switch ON. If it does not stay on, perform A+ checks (Paragraph 3.3.3).
3. Note movement of control wheel in the direction of the Artificial Horizon. Turn Roll knob full left and right and note control wheel responds to command.
4. If command wheel does not respond to commands or a gyro signal, rock the control

wheel to see if roll servo is engaged. In either case insert a Power Section Test Box 66D141-2 Set (See Fig. 3-10) to the A/C voltage and AMPL-MTR positions.

NOTE: It may be easier at this time to remove the amplifier and bench check.

Turn the autopilot back on and observe the Power Section solenoid pilot light is on. This will indicate the presence of solenoid voltage and the solenoid should be engaged. Command left and right turns and observe the meter for left and right amplifier output. If there is no solenoid voltage or amplifier output the problem is either in the wiring or the amplifier. (Check the servo if the solenoid voltage and amplifier output is present on the Power Section. See paragraph 3.2.3, Test 3.) Check the wiring from CD-47 to the amplifier as follows:

CD-47	to	Amplifier Plug
Pin A.....		Pin M
Pin B.....		Pin R
Pin C.....		Pin E
Pin D.....		Pin D

If wiring checks, the problem is likely within the amplifier.

5. With the Roll knob centered the control wheel should turn in the direction of any noticeable offset in the Artificial Horizon. If it does not use the gyro substitute 66D141-1 set on roll. Simulate left and right roll. If the control wheel follows these errors the Artificial Horizon should be checked for electrical output. If there is not action from control wheel there may be a wiring problem or a defective amplifier.

Check wiring to Artificial Horizon as follows:

CD-18	to	Amplifier Plug
Pin A.....		Pin B
Pin B.....		Pin C
Pin C.....		Pin G
Pin D.....		Pin D
Pin E.....		Pin 13
Pin F.....		Pin 12
Pin H.....		Pin 8

6. Press HDG ON. Verify the Radio Coupler is in the HDG mode if installed. Rotate Roll knob and see that it has no affect on amplifier output. If not, proceed to Step 8.
7. If both the Roll Command knob and the Directional Gyro (D.G.) Course Selector have an effect on the control wheel the amplifier is probably defective. If the heading "bug" has no affect on the control wheel but the Roll knob has, use the Console Substitute 66D141-3 to see if the console is defective. See Fig. 3-11 for Console Substitute Test Set-up.

NOTE: To check the D.G. in the aircraft the Artificial Horizon should be level. If it is not level, erect the gyro or use the Gyro Substitute set at 0° and Roll. It is helpful to use a Power Section in line with the servo, but not necessary. Amplifier output will be seen

QUICK CHECKS
CENTURY III TROUBLESHOOTING LOGIC CHART

FIGURE 3-6

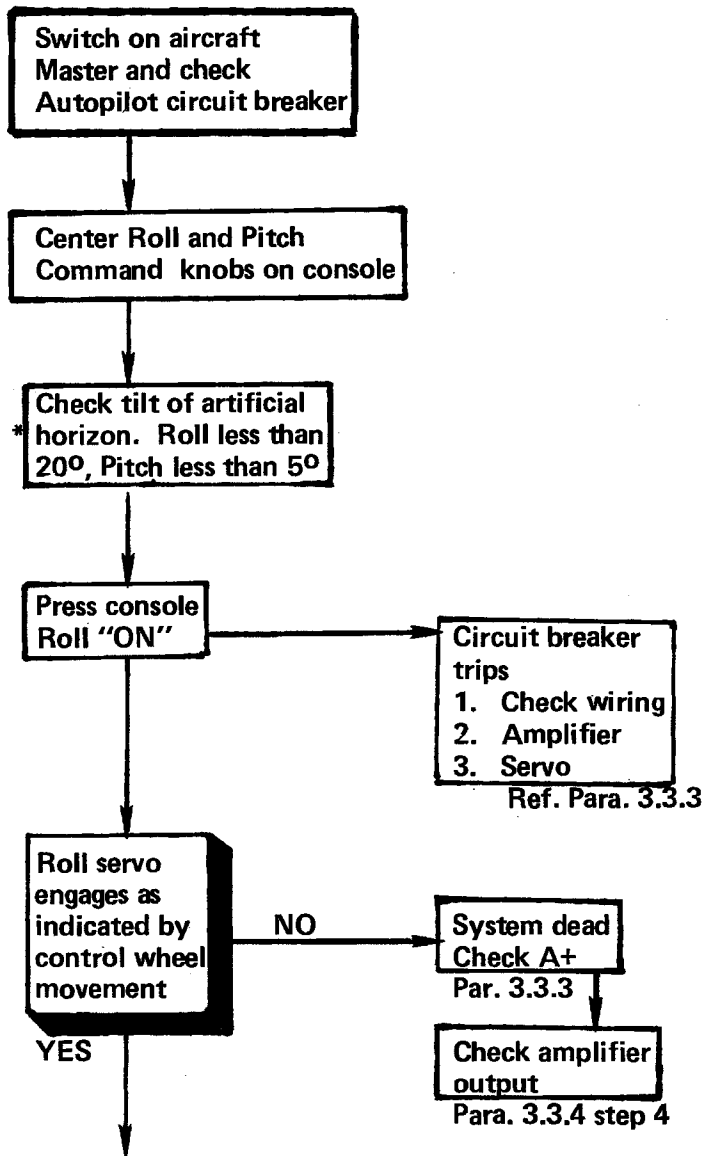

* In the roll mode the roll command knob provides the equivalent of 30° left or right bank command to the system. If the artificial horizon is tilted more than 30° during ground checks it will be impossible to null control wheel movement whenever the Century II is switched on. NOTE: Some tilt in the artificial horizon may be helpful in determining proper operation of the system. For example if the horizon indicated 20° right bank the roll command knob, will need to be rotated nearly full right to obtain a null. This indicates the presence of both a horizon and command signal. If the horizon is tilted more than approximately 5° in pitch the servo will drive in one direction continuously making complete tests impossible.

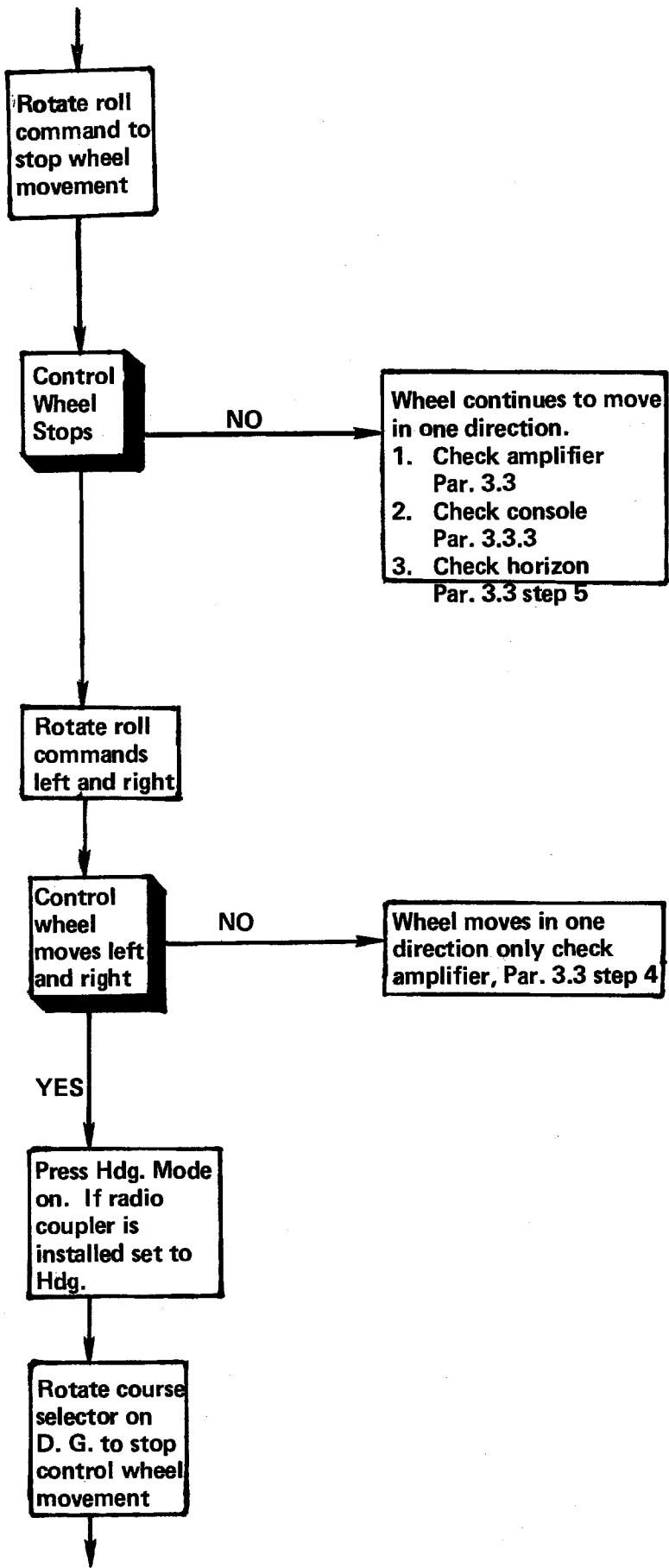

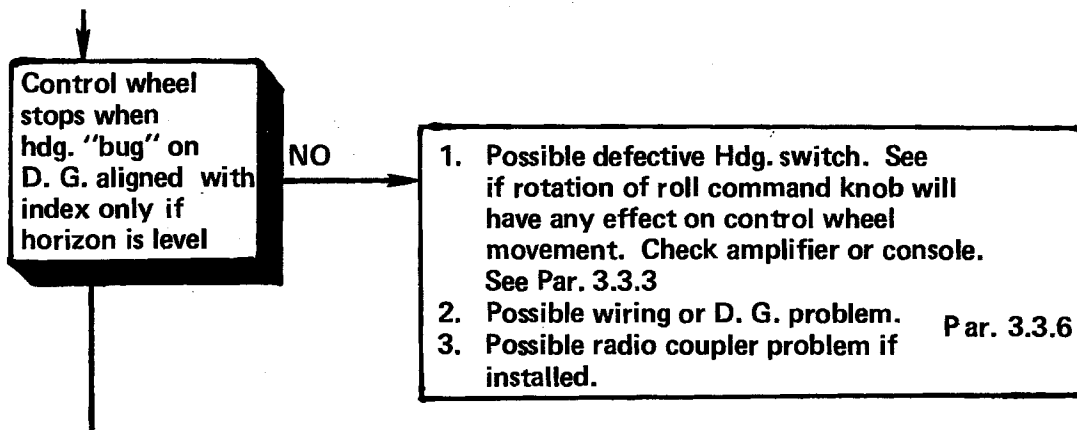

Radio Coupler Checks

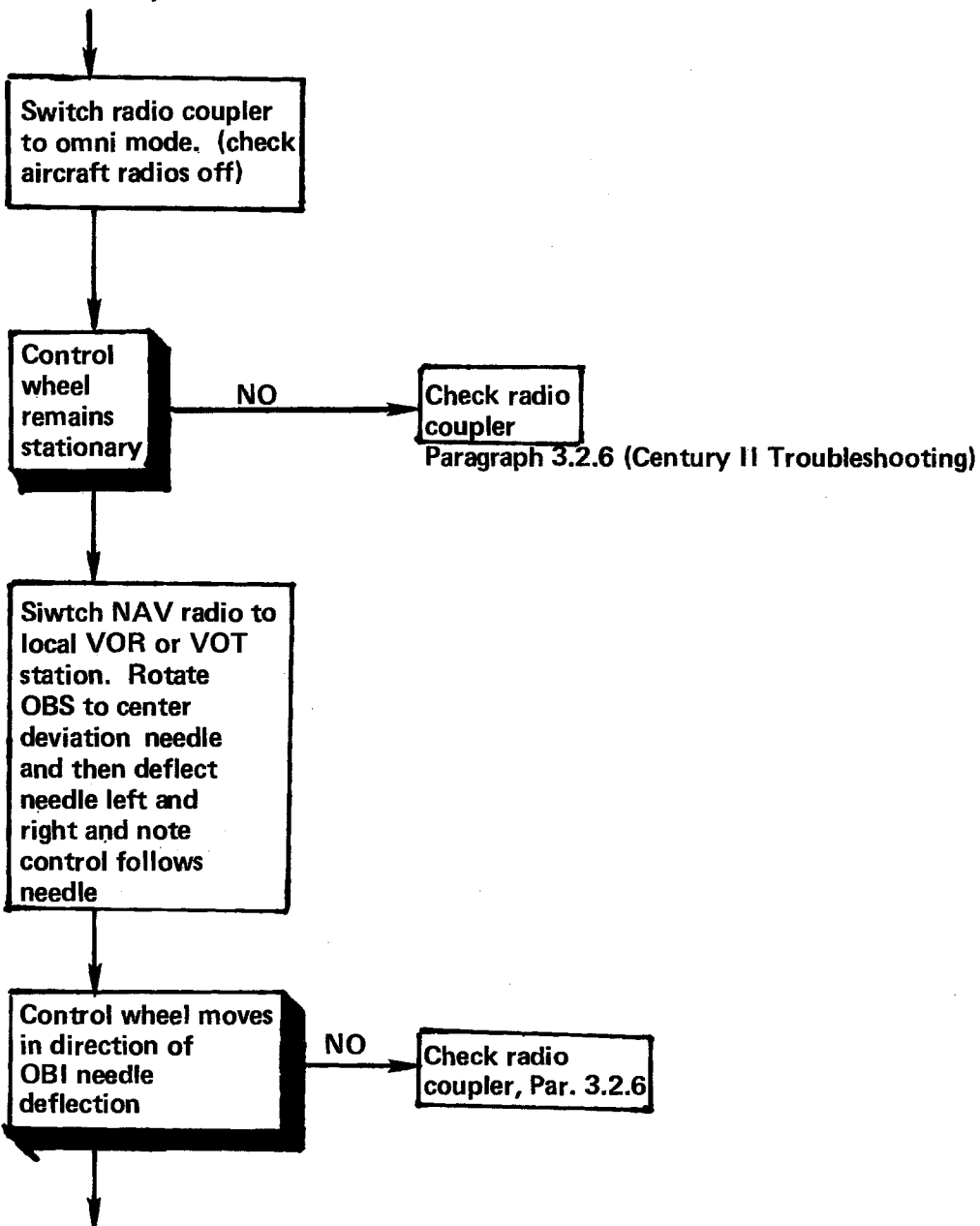

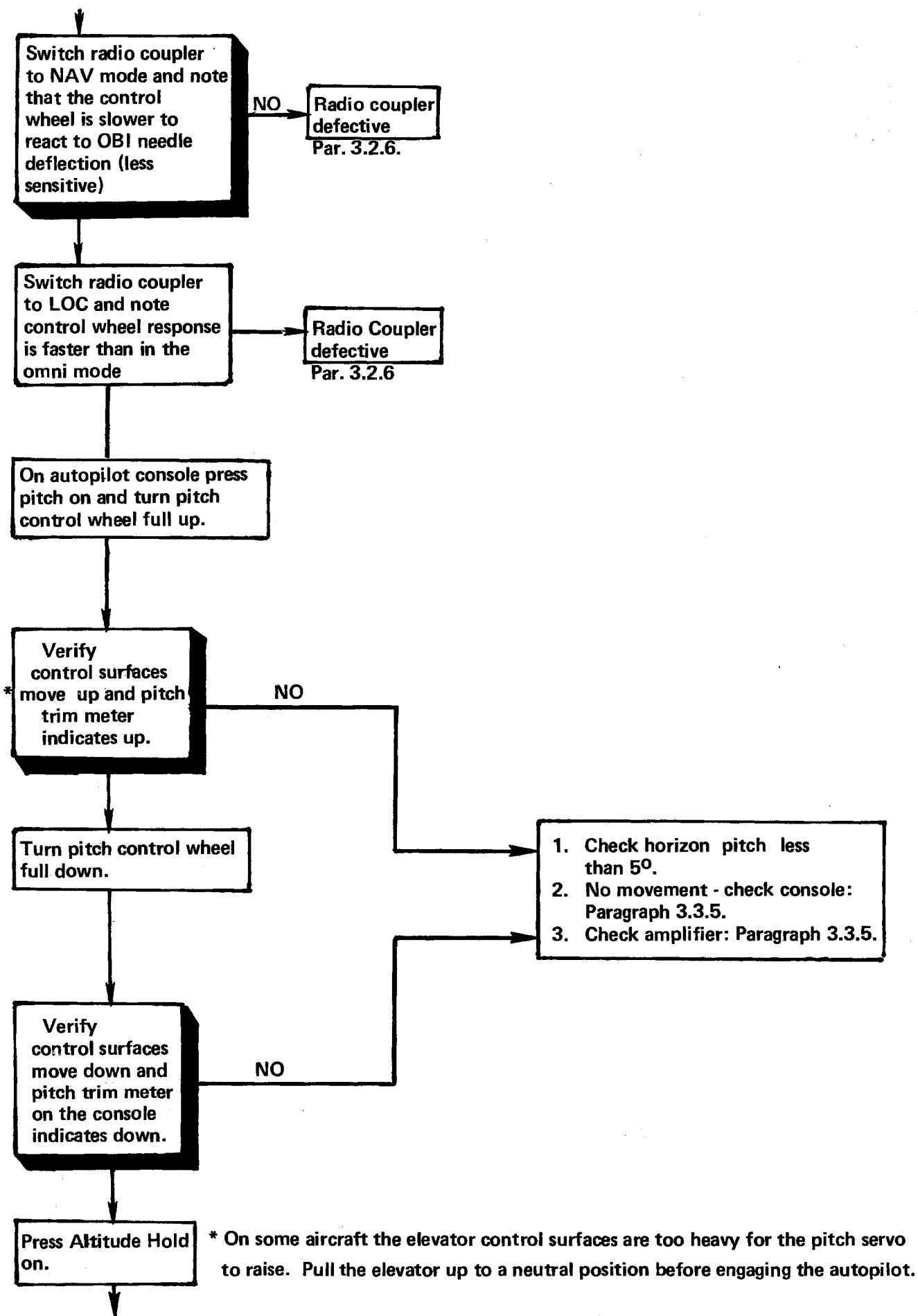

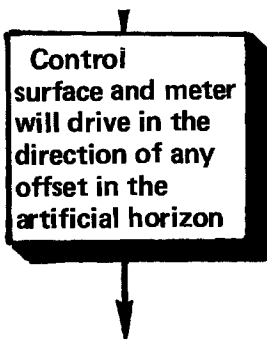

NOTE:
The only accurate way to check output of altitude hold is to remove and check on the bench.

The glide slope coupler cannot be checked without inserting test equipment or by using a glide slope ramp generator. Refer to Paragraph 3.3.7 for these tests.

Automatic pitch trim should engage when manual pitch is engaged. Note: Elevator control surfaces may have to be blocked for trim tests.

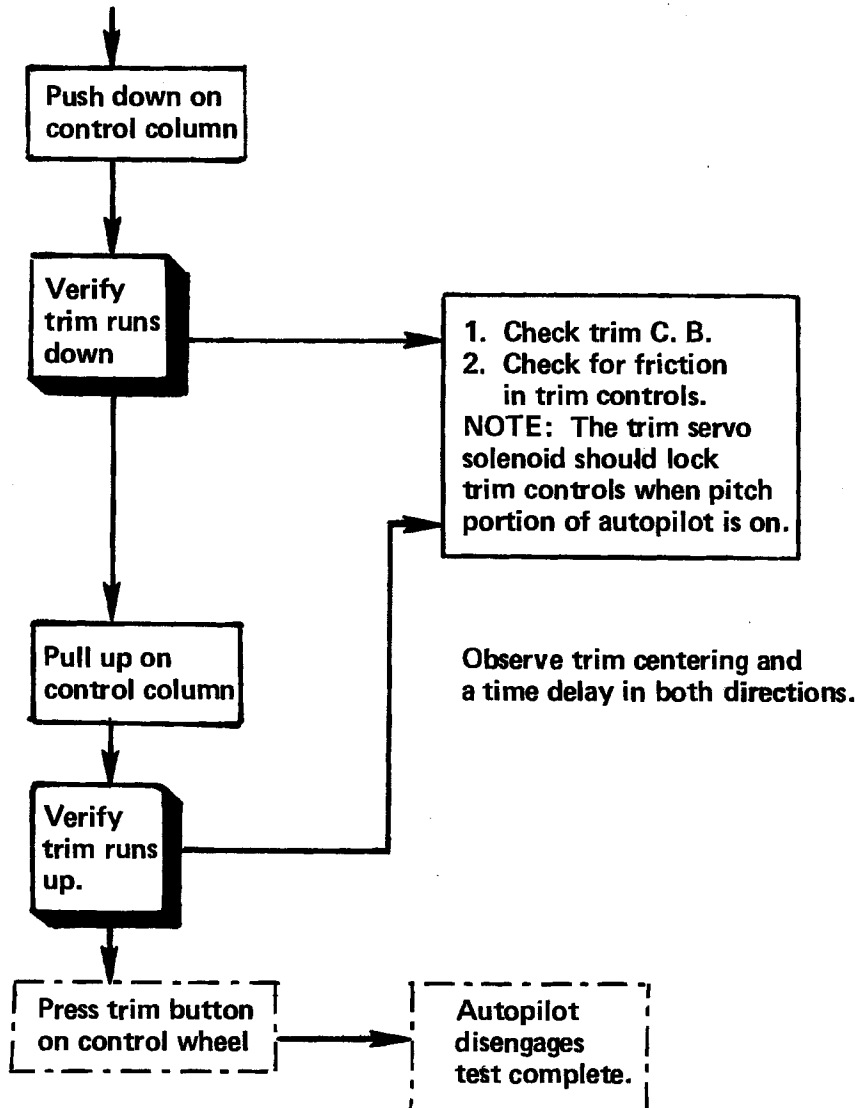

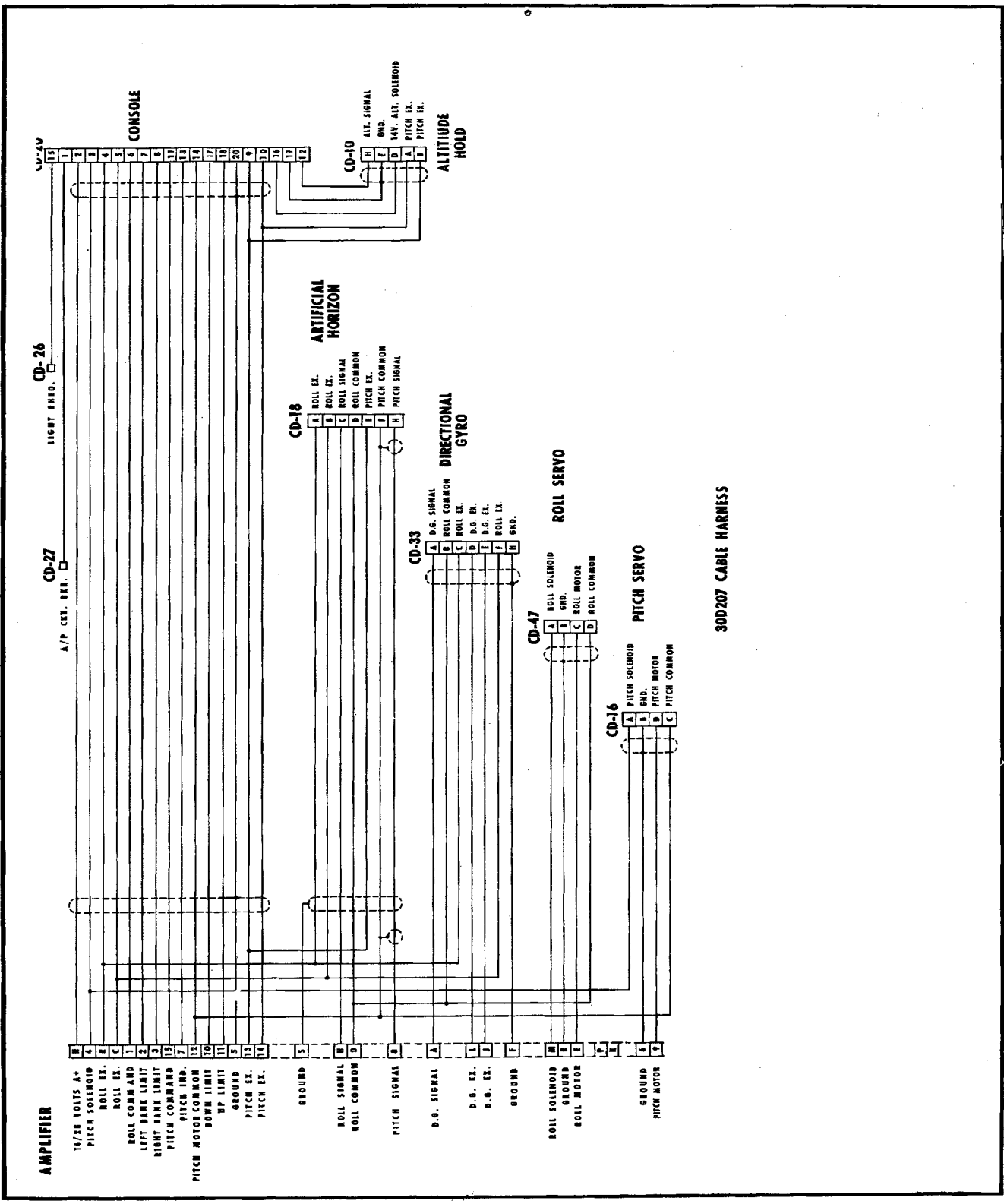

FIGURE 3-7
CENTURY III
INTERCONNECT WIRING DIAGRAM

through control wheel movement as well as the Power Section, if connected. Keep in mind that ± 3 Volts is about the point where the servo starts to run.

8. Rotate the Course Selector on the D.G. so the heading bug is aligned with the zero index. This will produce a zero output as indicated on the Power Section or no movement in the control wheel. The Course Selector has a command authority of up to 20° in roll. With the HDG bug set beyond 45° off course, it should be possible to cancel the output of the amplifier with 20° of roll + 5° . Set $20 + 5$ of roll on the Gyro Substitute in the direction of course deviation and note control wheel movement stops.

If the rotation of the Course Selector fails to produce the reactions as described, it is likely that the D.G. signal is not reaching the amplifier.

9. Loss of D.G. signal can normally be attributed to a defective D.G., console, Radio Coupler or wiring.
 - a. To eliminate the D.G. as a possibility, substitute the 66D141-1 Gyro Substitute in place of the D.G. See Fig. 3-9 for test set-up.
 - b. To eliminate the Radio Coupler, simply disconnect CD-33 from rear of coupler and connect it directly to the D.G.
 - c. Check wiring from CD-33 to the amplifier plug as follows:

CD-33	to	Amplifier Plug
Pin A		Pin A
Pin B		Pin D
Pin C		Pin B
Pin D		Pin L
Pin E		Pin J
Pin F		Pin C
Pin H		Pin F

- d. Checks on the console are made by substitution as noted in Step 7.

3.3.5 Pitch Section Checks - On some aircraft the elevator control surfaces are too heavy for the pitch servo to raise. It may be necessary to pull the elevator up and hold a neutral pressure while checking the pitch portion.

In aircraft equipped with automatic pitch trim, be careful not to run the trim to its limits. Pull the trim circuit breaker if necessary.

1. Before engaging the pitch portion watch the trim meter on the console as you command an up and down with the Pitch Command Wheel. The trim meter will indicate the direction commanded.

The circuitry for the trim indicator is contained in the console. If the pitch system works except for the trim indicator the problem is probably in the console.

2. Press "Pitch" on. Check solenoid engaged. Command an up and down and see that elevator follows. If the solenoid does not engage use the Console Substitute 66D141-3 (Fig. 3-11) to eliminate the console as a problem. If the console checks, insert a Power Section (Fig. 3-10) in line with the pitch servo (CD-16). If the solenoid pilot lamp lights, solenoid voltage is present at CD-16. The problem is in the pitch servo. If there is not solenoid voltage at CD-16 there is a wiring problem between CD-66 pin A and CD-20 pin 3.

3. If there is no amplifier output (servo drive) and the trim meter on the console is operating normally, in most cases the amplifier is defective. It may be easier to bench check the amplifier at this point than to get to the pitch servo. If not, use a Power Section connected to CD-16 to check for amplifier output.
4. Press "Alt. Hold" on. The trim meter and the servo will drive in the direction of any offset in Artificial Horizon. The Pitch Command Wheel should have no effect on amplifier output. Most switching problems will be in the console so use the Console Substitute to eliminate the console as the cause of any problem. There is no way to check the output of the Altitude Hold accurately in the aircraft. It should be removed and checked on the bench.

3.3.6 Radio Coupler Checks - Checks on the Radio Coupler are identical to those described in paragraph 3.2.6 (Century II Troubleshooting).

3.3.7 Glide Slope Coupler Checks:

1. Remove aircraft harness connector CD-58 from Glide Slope Coupler cable. Connect test cable 30A300 CD-58 to Glide Slope Coupler Harness. Connect plug CD-34 on 30A300 test cable to CD-34 on 66D141-4 coupler tester. Attach 30A300 ground clip to ground. See Fig. 3-10.

NOTE: Connection of clip to ground eliminates the requirement of the Radio Coupler being in the "LOC NORM" position.

2. Start engine to erect gyro or use Gyro Substitute set on 0°, Pitch.
3. Rotate Radio Substitute on Radio Coupler Tester to 100% up (blue).
4. Push "Roll" on and rotate Roll Command Knob to stop any aileron movement.
5. Push "Alt" on.
6. Wait at least 30 seconds, then slowly decrease Radio Signal Substitute to zero on Coupler Tester meter.
7. The Glide Slope Coupler should lock on at $0 \pm 10\%$ of Radio Substitute. The green "Lock On" light should illuminate.
8. Rotate Radio Signal Substitute knob to 100% up and observe control column moves nose up. Rotate knob to 100% down and control column should move nose down. Again on some aircraft it may be necessary to manually assist control column.

3.3.8 Automatic Pitch Trim

The importance of automatic pitch trim in the autopilot Pitch or Alt. modes cannot be over-emphasized. Many problems reported in the autopilot modes may be the result of a malfunction in the trim system, such as a trim sensor imbalance or no time delay in one direction. The best test procedure is to follow the trim system ground checks in Section VI (6.2) for the type of trim system in the aircraft. Identify exactly which type of trim system is in the aircraft by referring to Section II under the aircraft model and S. T. C. number and identify the pitch trim servo part number or trim amplifier part number. The following chart will identify the trim amplifier part number and the methods used to test the trim system as well as other parts used on the trim servo.

TRIM AMPLIFIER PARTS CHART

SERVO NO. 1C373	SERVO RPM ACTUATOR 14V.	SWITCH POS.	WIRING SCH.	CAPSTAN ITEM	CLUTCH SETTINGS LBS.	AMPLIFIER ITEM
1-275	1C491-3 (3)	R	A	49A26-1	31 ⁺³ / ₂	79C54-1
4-278	1C491-3 (3)	R	B	49A26-1	31 ⁺³ / ₂	-
1-197	1C491-2 (6)	L	A	49A26-1	25 ⁺ / ₅	79C54-1
1-233	1C491 (30)	L	A	44A108-1	14 ⁺ / ₄	79C54-1
4-276	1C491 (30)	R	B	44A108-1	14 ⁺ / ₄	-
1-220	1C491 (30)	R	A	49A26-1	25 ⁺ / ₅	79C54-1
3-287	1C491-1 (10)	R	A	44A108-1	30 ⁺ / ₅	79C53-1
3-315	1C491-2 (6)	L	A	49A26-1	26 ⁺ / ₇	1C646-14
1-331	1C491-3 (3)	L	A	49A26-1	25 ⁺ / ₂	79C54-1
1-264	1C491-3 (3)	R	A	49A26-1	35 ⁺ / ₅	79C54-1
1-218	1C491-2 (6)	R	A	49A26-1	25 ⁺ / ₅	79C54-1
5-316	1C491-2 (6)	R	A	49A26-1	26 ⁺ / ₇	1C671
5-315	1C491-2 (6)	R	A	49A26-1	26 ⁺ / ₇	1C671
4-365	1C491-1 (10)	R	B	49A26-1	36 ⁺ / ₄	-
5-242	1C491-(30)	R	A	49A26-1	25 ⁺ / ₅	1C671
4-361	1C491-1 (10)	R	B	49A26-1	32 ⁺ / ₃	-
1-368	1C491-2 (3)	L	A	49A26-1	25 ⁺ / ₅	79C54-1
3-233	1C491-(30)	L	A	44A108-1	14 ⁺ / ₄	79C53-1
-3-362	1C491-1 (10)	R	A	49A26-1	36 ⁺ / ₄	79C53-1
-3-383	1C491-1 (10)	L	A	49A26-1	25 ⁺ / ₅	79C53-1
-1-270	1C491-2 (3)	R	A	49A26-1	22 ⁺³ / ₂	79C54-1
-4-410	1C491-2 (6)	L	B	49A63-1	25 ⁺ / ₅	-
4-419	1C491-2	R	B	49A26-1	23 ⁺ / ₃	-
5-417	1C491-3	R	A	49A63-1	33 ⁺ / ₃	-

SERVO NO.	SERVO RPM ACTUATOR	SWITCH POS.	WIRING SCH.	CAPSTAN ITEM	CLUTCH SETTINGS	AMPLIFIER ITEM
1C469-	28V.				LBS.	
-1-279	1C492-2 (6)	R	A	49A26-1	23 ⁺² / ₃	79C54-2
-1-270	1C492-1 (10)	R	A	49A26-1	20 [±] 3	79C54-2
-1-239	1C492-2 (6)	R	A	49A26-1	21 [±] 3	79C54-2
-1-291	1C492-1 (10)	L	A	49A26-1	37 [±] 3	79C54-2
-1-219	1C492-2 (6)	L	A	49A26-1	25 [±] 5	79C54-2
-1-222	1C492-2 (6)	R	A	49A26-1	25 [±] 5	79C54-2
1C469-4	1C492-1 (10)	R	B	49A26-1	25 [±] 5	-
-1-194	1C491-1 (6)	R	A	49A26-1	26 ⁺⁶ / ₇	79C54-2
-1-292	1C492-2 (6)	L	A	49A26-1	35 ^{±3} / ₂	79C54-2
-1-300	1C492-2 (6)	L	A	49A26-1	25 [±] 1	79C54-2
-1-299	1C492-4 (30)	R	A	49A26-1	10 [±] 2	79C54-2
-1-302	1C492-2 (6)	R	A	49A26-1	19 [±] 2	79C54-2
-1-303	1C492-2 (6)	L	A	49A26-1	25 ^{±5} / ₂	1C646-28
-1-221	1C492-1 (10)	L	A	49A26-1	20 [±] 2	79C54-2
-1-308	1C492-2 (6)	L	A	49A26-1	25 [±] 5	79C54-2
-1-313	1C492-2 (6)	R	A	49A26-1	28 ⁺¹⁰ / ₉	1C646-28
-5-336	1C492-1 (10)	R	A	49A35-1	30 [±] 5	1C671-1
-4-344-1	1C492 (20)	R	B	49A35-1	45 [±] 5	-
-5-353	1C492 (20)	L	A	49A26-1	20 [±] 5	1C671-1
-1-367	1C492-3 (3)	R	A	49A26-1	25 [±] 5	79C54-2
-1-273	1C492 (20)	R	A	49A26-1	20 [±] 5	79C54-2
-4-377	1C492-2 (6)	L	B	49A26-1	28 [±] 5	-
-4-221	1C492-1 (10)	L	A	49A26-1	20 [±] 2	-
-318	1C492-1 (10)	R	A	49A26-1	25 [±] 2	-
-345	1C492-2 (6)	L	A	49A26-1	16 [±] 3	-

SERVO NO.	SERVO RPM ACTUATOR	SWITCH POS.	WIRING SCH.	CAPSTAN ITEM	CLUTCH SETTINGS	AMPLIFIER ITEM
1C-469	28V.				LBS.	
-1-388	1C492-3 (3)	L	A		35±5	79C54-2
-5-371	1C492-4 (30)	R	A	49A26-1	25±5	1C671-1
-4-381	1C492-4 (30)	R	B	49A26-1	25±5	—
-5-303	1C492-3 (3)	L	A	49A26-1	25± ⁵ / ₂	1C671-1
-3-291	1C492-1 (10)	R	A	49A26-1	37±3	79C53-2
-1-377	1C492-1 (6)	L	A	49A26-1	28±5	—
-422	1C492-1 (10)	R	A	49A26-1	25±2	—
-1-407	1C492 -2 (6)	L	A	49A26-1		79C53-2
1C345	12V.					
1C345-186	1C491 (30)	R	A	49A26-1	25±5	79C53-1
1C345-183	1C491 (30)	R	A	49A26-1	18±3	79C53-1
1C345-4-272	1C491 (30)	R	B	49A26-1	18±3	---
1C345-1-265	1C491 (30)	R	A	49A26-1	18±3	79C53-1
1C345-4-267	1C491 (30)	R	B	49A26-1	25±5	---
1C345-184	1C491 (30)	R	A	49A26-1	25±5	79C54-1
1C345-1-184	1C491 (30)	R	A	49A26-1	25±5	79C53-1
1C345-1	1C491 (30)	R	B	49A26-1	25±5	---
1C345-5-184	1C491 (30)	R	A	49A26-1	25±5	1C671
1C345-1-298	1C491 (30)	R	A	49A26-1	20±5	79C53-1
1C345-4-321	1C491 (30)	R	B	49A26-1	20±5	---
1C463	24V.					
1C463-1-187	1C492 (20)	R	A	49A26-1	20±5	79C53-2
1C463-2-187	1C492 (20)	R	A	49A26-1	20±5	79C54-2
1C463-1-290	1C492 (20)	L	A	49A26-1	35±5	79C53-2
1C463-1	1C492 (20)	R	A	49A26-1	20±5	---

TABLE 4-2
TRIM AMPLIFIER TEST PROCEDURES & CENTERING ADJUSTMENTS

AMPLIFIER	SWITCH	TEST PROCEDURE	CENTERING ADJUSTMENTS	(SENSOR TYPE)
1B369 or 1B389	Push Button	6.3.2 Step 3	6.2.2	Single Point Contact
79C53	Rocker Type	6.3.2 Step 1	6.2.2	Single Point Contact
79C54	Push Button	6.3.2 Step 3	6.2.2	Single Point Contact
1C646	Push Button	6.3.2 Step 3	6.2.2 Step 5	Dual Point Contact
1C671	Rocker Type	6.3.2 Step 1	6.2.2 Step 5	Dual Point Contact

SCHEMATIC - B
 FOR MANUAL TRIM ONLY

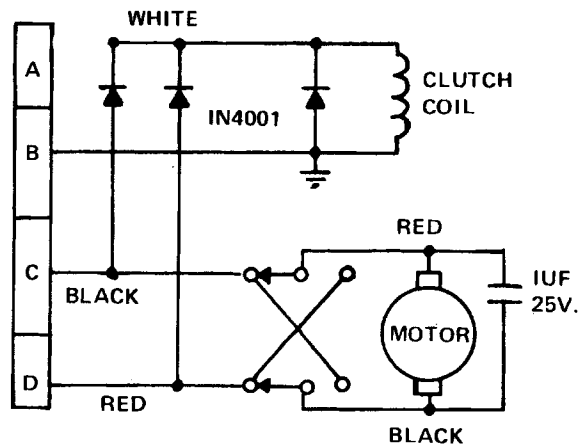

SCHEMATIC - A

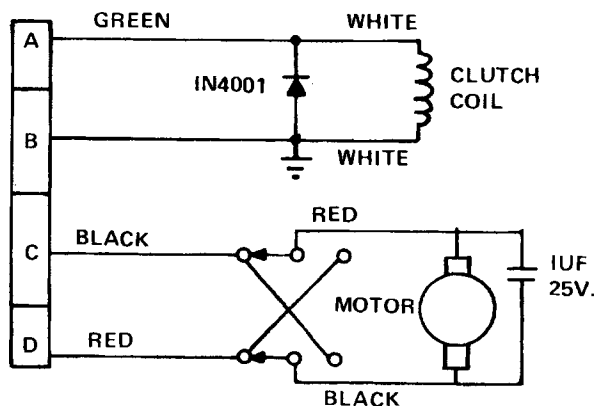

SWITCH SHOWN IN R POSITION.

SECTION IV REPAIR AND OVERHAUL

4.1 GENERAL

This section contains theory, schematics and bench test procedures for each major component of the Century II and III Autopilot systems. Each component is listed under a sub-section number such as 4.2, Century II Console Amplifier; 4.3, 1D395 Amplifier; etc. By referring to the table of contents, the appropriate test and related information (i.e. schematics) for any component can quickly be found without paging through a lot of unrelated data.

Paragraph 4.10 and 4.11, at the rear of this section, discuss the fundamental theory of phase detectors and synchronous filters as they are applied within the Century II and III Autopilots. These sub-sections are intended as a supplement to the individual component theory. Both of these circuits are used throughout the Century series autopilots. Therefore, understanding their operation will be of great importance when troubleshooting.

4.2 1C385 CENTURY II AND IIB CONSOLE AMPLIFIER

- 4.2.1 (a) Century II Theory - The Century II Console/Amplifier may be divided, for the purpose of discussion, into two sections with one consisting of the oscillator and the other, the lateral control circuits.

In figure 4.1 (a), Century II Schematic, the reference oscillator is shown in the lower left side of the schematic and is composed primarily of Q-15, Q-16, CR-7 and T-1.

A(+) (pin N) is applied to the oscillator from the console/amplifier master through R-42 (and R-40 in a 28V system); Q-19 and CR-7 regulate the supply voltage to +11VDC.

The frequency of the oscillator is determined by the series tuned circuit in the Directional Gyro. This tuned circuit, excited by a secondary winding on T-1 (pins 2 & 3) provides a square wave trigger of opposite phases to the base of each oscillator transistor (Q-15 and Q-16). Q-15 and Q-16 conduct alternately inducing a 5KHz square wave in the primary of T-1.

Roll excitation ($28 \text{ VP-P} \pm 10\%$), is taken from the secondary of T-1 across the yellow and red leads. Roll excitation is used to excite the artificial horizon and the synchronous filters in the amplifier. Excitation for the phase detector is also taken from the secondary of T-1 (from pins 6, 7 and 8). A portion of the secondary from the green and orange lead is rectified by CR-14 and filtered by C-12 to provide a D. C. supply to the signal amplifiers and synchronous filters.

The lateral control circuits begin with Heading Switch. In the roll mode, the roll signal from R-3 is applied to the first asynchronous filter (Q-2 and Q-3) through R-38. In the Heading Mode, the DG signal from the Directional Gyro is amplified by Q-1 and then applied to the first synchronous filter through R-6. R-8 provides a roll (or heading) centering signal to the first synchronous filter.

The first synchronous filter introduces bank angle limiting by R-10 and R-14 limiting the maximum signal across the filter. For a detailed description of a synchronous filter, refer to Paragraph 4-11.

The output of the first filter is applied across R-15 to be summed with the roll position signal across R-16 from the Artificial Horizon (Roll Signal at pin H). The resultant signal is applied to the base of Q-4. Q-4 amplifies this signal and applies it through R-19 to the second synchronous filter Q-5 and Q-6.

The second synchronous filter introduces a form of feedback from an analog circuit made up of CR-8, CR-9 and C-8. This circuit, often called the electronic follow-up, takes the place of a control surface follow-up element on a short term basis. The back-to-back diodes duplicate the lost motion inherent in the servo motor drive as it responds to the amplifier output. One diode conducts when the output of the servo amplifier reaches about ± 3 volts or that amount required to start the servo motor.

The D. C. signal from the diodes is applied across C-8 (and increases as C-8 charges) to the synchronous filter which chops the signal into a square wave and sums it with the signal across the synchronous filter is an error signal representing an imbalance between Command signal and Roll signal.

The error signal causes aileron movement to roll the aircraft toward the null or satisfy the command signal at the summing point of Q-4. The follow-up signal has only enough authority to help stop or neutralize aileron movement to keep the aircraft from overshooting the commanded attitude or to prevent a roll oscillation around that attitude.

The output of the second filter is applied through R-22 to the base of Q-7. Q-7 amplifies the signal and transformer couples it to the phase detector. From the phase detector, a proportional D. C. signal is applied to the servo amplifier which drives the roll servo. For a detailed discussion of the phase detector refer to paragraph 4.12.

4.2.1(b) Century IIB Theory - A+, is applied through the master switch to the oscillator regulator through R-51 (and R-53 in a 28V amplifier). CR-16 and Q-22 regulate the oscillator supply voltage to + 11 VDC. See figure 4-1 (C).

The frequency of the oscillator 5KHZ is determined by the series tuned circuit in the Directional Gyro. This tuned circuit, excited by a secondary winding of T-1 (2-3) provides a square wave trigger of opposite polarity to the base of each oscillator transistor (Q-20 and Q-21). Q-20 and Q-21 conduct alternately inducing a 5KHZ square wave in the primary of T-1.

Roll excitation ($27\text{vp-p} \pm 1\text{V}$) is taken from the secondary of T-1 across the yellow and red leads. Roll excitation is used to excite the roll pick-off in the artificial horizon and the synchronous filters in the amplifier. Excitation for the phase detector is also taken from the secondary T-1, (from pins 6, 7 and 8). A portion of the secondary from the green and orange leads to rectified by CR-8 and filtered by C-18 to provide a D. C. supply to the signal amplifier and synchronous filters.

The roll section begins with the Directional Gyro signal switch Q-1. In the HDG mode Q-1 is turned off allowing the Directional Gyro (D. G.) signal from pin A of the amplifier plug to be applied to the base of Q-2, amplified and applied to the first synchronous filter. In the Roll mode the command signal from R-4 provides a D. C. path through R-1 to bias Q-1 on. With Q-1 turned on, the voltage across R-5 will cause Q-2 to go into saturation, blocking the D. G. signal. The Roll command signal will be applied to the first synchronous filter through C-1 and R-20.

The first synchronous filter Q-5 and Q-6 introduces bank angle limiting. R-16 and R-18 will limit the amplitude of left or right commands individually across the filter. Roll-centering is also applied to the filter from R-10 through R-9. Across the collectors of Q-5 and Q-6 is a lag filter (Q-3 and Q-4) that limits the rate of change in the command signals. For a detailed description of synchronous filters refer to paragraph 4.11.

The output of the first filter is applied across R-21 and summed with the Roll signal from the Artificial Horizon (Roll signal at pin R-22). The resultant signal is amplified by Q-7 and applied to the second synchronous filter (Q-8 and Q-9).

On one side of the second synchronous filter (Q-9) feed-back is introduced from the non-linear follow-up circuit. Like the non-linear diodes in the Century II amplifier, Q-12 and Q-13 control the follow-up signal to the synchronous filter. This network was introduced in place of the non-linear diodes because it can be adjusted to match the autopilot more closely with the dynamics of each aircraft. R-43 is the Threshold adjustment. Varying R-43 will vary the bias on the base of both transistors changing the level at which they will conduct. Q-12 (NPN) and Q-13 (PNP) will conduct with opposite polarity signals from the servo amplifier. When Q-12 is forward biased, Q-13 will be reverse biased and cut off. Q-12 will conduct when the output of the servo amplifier reaches approximately 3 volts, depending on the threshold adjustment. When Q-12 conducts feedback will be introduced through C-17, C-16, C-15 and C-14 decreasing the signal across the second filter and the gain of the amplifier. Q-13 will act on opposite polarity signals.

The output of the second filter through R-22 is applied to the base of Q-10. From the collector of Q-7, the amplified signal is transformer coupled to the phase detector.

From the phase detector, a D. C. signal proportional to the input is applied to the D. C. amplifier. The output of the D. C. amplifier is applied to the roll servo through pins D and E on the amplifier plug. For a detailed discussion of the phase detector, refer to paragraph 4-12.

4.2.2 Century II Console/Amplifier Tests

A. Test Equipment Required:

1. 66D141 Test Kit
2. Oscilloscope
3. Regulated Power Supply

NOTE: Refer to Figures 4-1 and 4-8 as necessary.

B. Test Set-Up:

1. Connect test equipment as shown in Fig. 4-2
2. Gyro Substitute Roll-Pitch Switch in Roll.
3. Set D.G. and horizon to 0.
4. Power Section Tester in AMP-RES position.
5. Voltage selector switches set to power supply voltage.
6. Turn system on.

C. Oscillator and Regulator Checks:

1. Set oscilloscope as follows:
 - (a) Horizontal sweep time - 50u/sec.
 - (b) Vertical input to 10 volts per cm.
 - (c) AC-DC to D.C.
2. Monitor roll excitation pins B and C with oscilloscope.
3. For 14V units, vary the power supply from 12 to 15 vdc. For 28V units, vary the power supply from 24 to 30 vdc. Scope presentation should be 28 + 2.8v p-p.
4. Disconnect scope.

D. Bank vs. Heading Command:

1. Set D.G. and horizon to 0. (66D141-1).
2. Engage HDG on Console/Amplifier.
3. Set D.G. to 10° left. Roll horizon should null output at 10° +2/ -1 left. (Output is read on Power Section Meter.)
4. Set D.G. to 10° right. Roll horizon should null output at 10° +2/ -1 right. (See Fig. 4-8.)

E. Threshold Sensitivity:

1. Set D.G. to 0.
2. Offset the horizon vernier enough to produce 2 volts output in Power Section Meter. Record setting.
3. Reverse the horizon to produce 2 volts in the opposite direction. The difference between the two settings shall not exceed 2.5° .

F. Bank Limiting:

1. Set left and right bank adjustments on the console to minimum limit (CCW).
2. Set D.G. to 45° left. No more than 15° left horizon shall be required to null output on Power Section. (See Fig. 4-8).
3. Set D.G. to 45° right. No more than 15° right horizon shall be required to null output.
4. Set left and right bank adjustments on the console to maximum limit. (CW.)
5. Leave D.G. at 45° right. No less than 24° right horizon should be required to null output.
6. Set D.G. to 45° left. No less than 24° left horizon should be required to null output.
7. Set bank adjustments so 20° left and right horizon will produce a null output with 45° of left and right D.G. input.
8. Set D.G. to 0.

G. Trim Range:

1. Turn centering pot to full CW. Null output with horizon vernier. Record setting.
2. Turn centering pot to full CCW. Null output with horizon vernier. The difference between the two settings should be 6° or more.
3. Set horizon to 0 and null output with centering pot.

H. Manual Bank Limiting:

1. Push HDG Switch off.
2. Turn Command Knob full CW. Horizon should not exceed 30° right to null output.
3. Turn Command Knob full CCW. Horizon should not exceed 30° left to null output.

NOTE: Bank limiting must be set at 20° in HDG mode.

4.2.3 Century IIB Console/Amplifier Tests

A. Test Equipment Required:

1. 66D141 Test Kit
2. Oscilloscope
3. Regulated Power Supply

NOTE: Refer to Figures 4-1 and 4-8 as necessary.

B. Test Set-Up:

1. Connect test equipment as shown on Fig. 4-2.
2. Set Gyro Substitute Roll-Pitch Switch to Roll.
3. Set D.G. and horizon to 0.
4. Power Section Tester in AMP-RES position.
5. Voltage selector switches set to power supply voltage.
6. Turn system on.

C. Oscillator and Regulator Checks:

1. Set oscilloscope as follows:
 - (a) Horizontal sweep time - $50\mu/\text{sec}$
 - (b) Vertical input to 10 volts per cm.
 - (c) AC-DC to D.C.

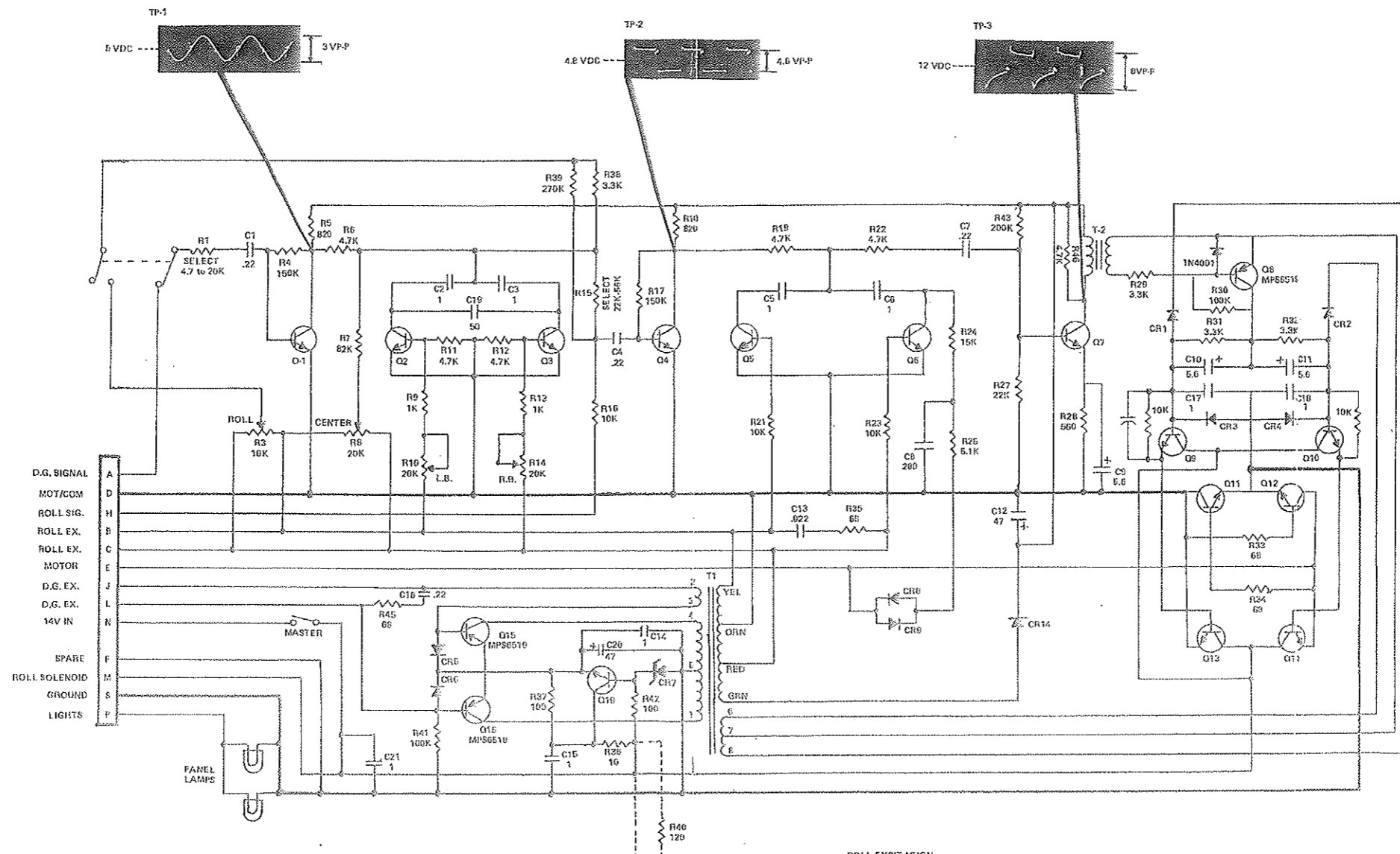

- NOTES:
1. ALL CAPACITOR VALUES ARE IN MFD.
 2. ALL DIODES ARE 1N4001 EXCEPT AS NOTED.
 3. Q1, 2, 3, 4, 7 ARE MPS6515.
Q5, 6, 10, 19, 9 ARE 2N3110
Q8, 15, 16 ARE MPS6519
Q11, 12, 13, 14 ARE 2N3055
 4. EARLY MODES USED 1N4001, LATER MODELS USE 1N5923 FOR CR6 AND CR9.

FOR 28V REMOVE CONNECTION AND ADD 120 OHM RESISTOR HERE.



- TEST POINTS
- NOTE: REFER TO FIGURE 4-2 FOR AMPLIFIER TEST SETUP. LIMIT ADJUSTMENTS MUST BE SET FOR 20° BANK LIMITS IN THE HEADING MODE. VOLTAGES AND WAVEFORMS SHOULD BE ± 20%.
- TP-1 SET D.G. SUBSTITUTE TO 10° LEFT, MEASURED FROM THE COLLECTOR OF Q-1 TO MOTOR/Common.
 - TP-2 MEASURED FROM THE COLLECTOR OF Q-4 TO MOTOR/Common.
 - TP-3 MEASURED FROM THE COLLECTOR OF Q-7 TO MOTOR/Common.
 - TP-4 MEASURED BETWEEN THE RED AND YELLOW LEADS OF T-1. ROLL EXCITATION.

FIGURE 4-1A
1C330 and 1C385 CENTURY II
CONSOLE AMPLIFIER

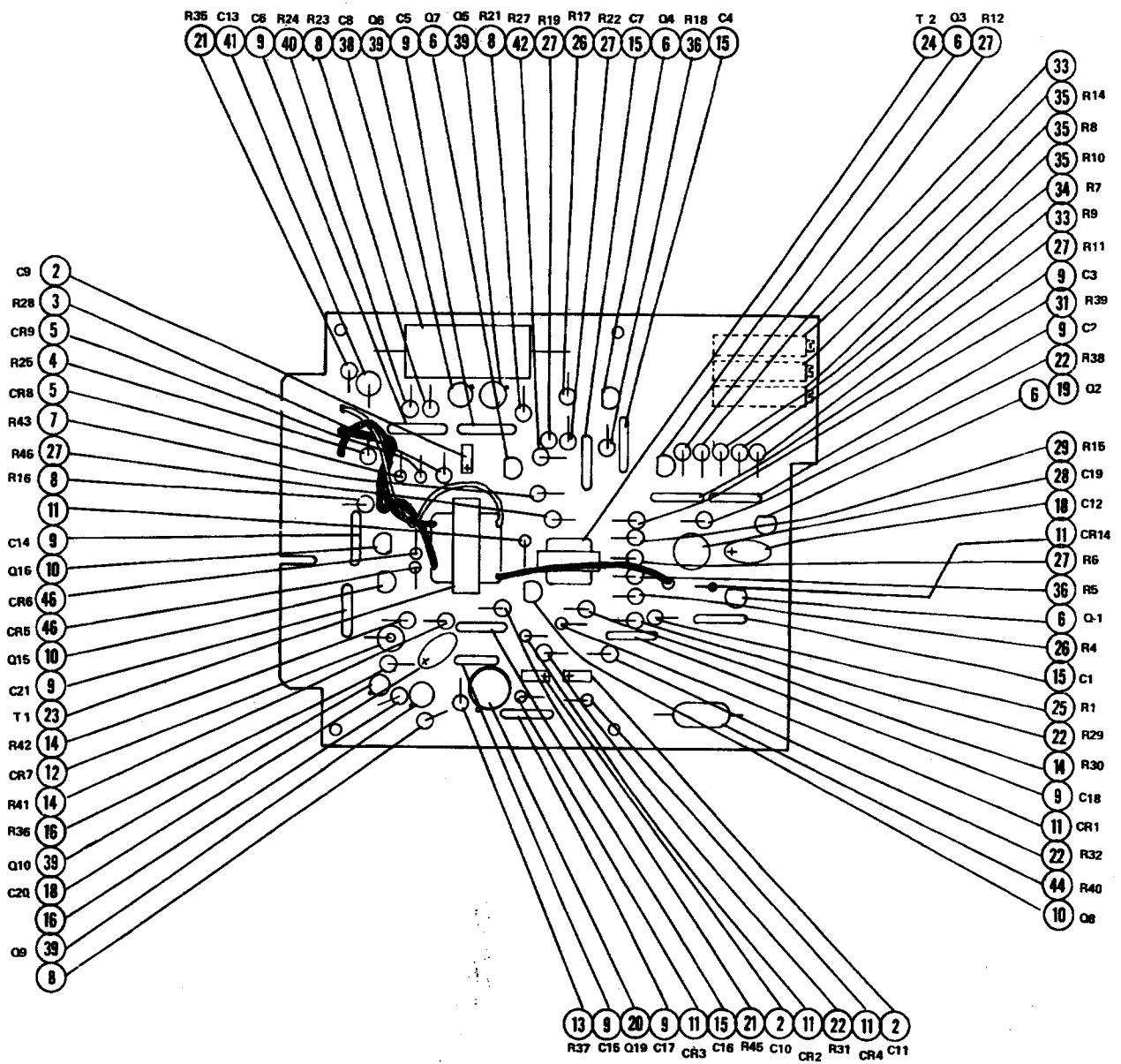
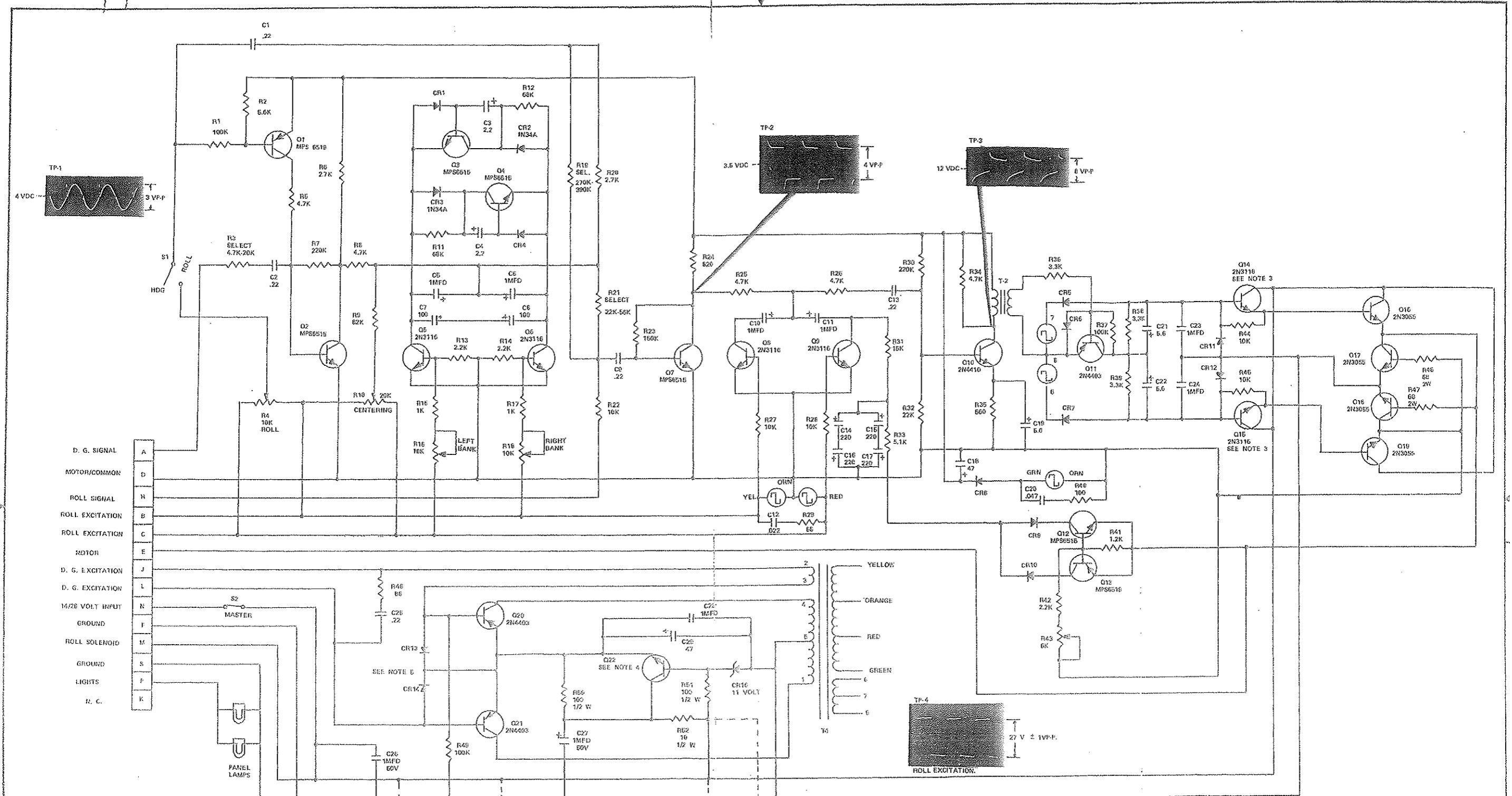

FIGURE 4-1B

CENTURY II CIRCUIT BOARD



- NOTES:
1. ALL CAPACITOR VALUES ARE IN MFD.
 2. ALL DIODES ARE 1N4001 EXCEPT AS NOTED.
 3. Q14 & Q15: BV5C0-60 VOLTS FOR 28 VOLT UNITS. PT No. 48502
BV5C0-40 VOLTS FOR 14 VOLT UNITS. PT No. 48542.
 4. EARLIER UNITS USED 48546 CHANGED TO 48562.
 5. EARLY UNITS USED 1N4001 LATER UNITS USE 1N4935 FOR CR13 & CR14.

FOR 28 VOLT REMOVE CONNECTION AND ADD 120 OHM RESISTOR R-53

FIGURE 4-1C
1C338 and 1C385 CENTURY II B
CONSOLE AMPLIFIER

TEST POINTS
 NOTE: REFER TO FIGURE 4-2 FOR AMPLIFIER TEST SET-UP. LIMIT ADJUSTMENTS MUST BE SET FOR 20° BANK LIMITS IN THE HEADINGS MODE. SET D. G. SUBSTITUTE TO 10° LEFT. VOLTAGES AND WAVEFORMS SHOULD BE ± 20 %.

TP-1 MEASURED FROM THE COLLECTOR OF Q-2 TO MOTOR/Common.
 TP-2 MEASURED FROM THE COLLECTOR OF Q-7 TO MOTOR/Common.
 TP-3 MEASURED FROM THE COLLECTOR OF Q-10 TO MOTOR/Common.
 TP-4 MEASURED BETWEEN THE RED AND YELLOW LEADS OF T-1.

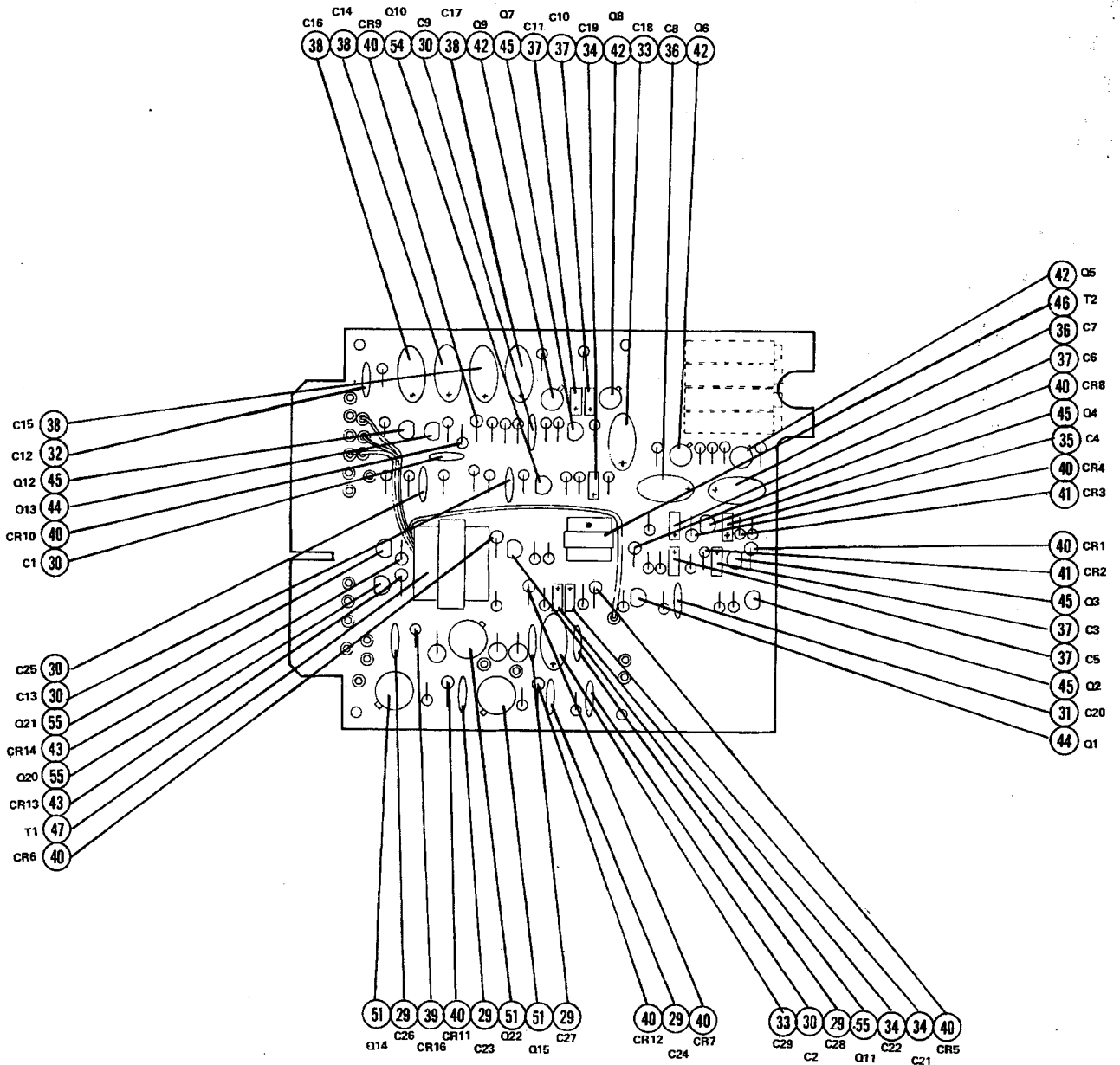

CAPACITORS TRANSISTORS AND DIODES

FIGURE 4-1D

CENTURY IIB CIRCUI BOARD

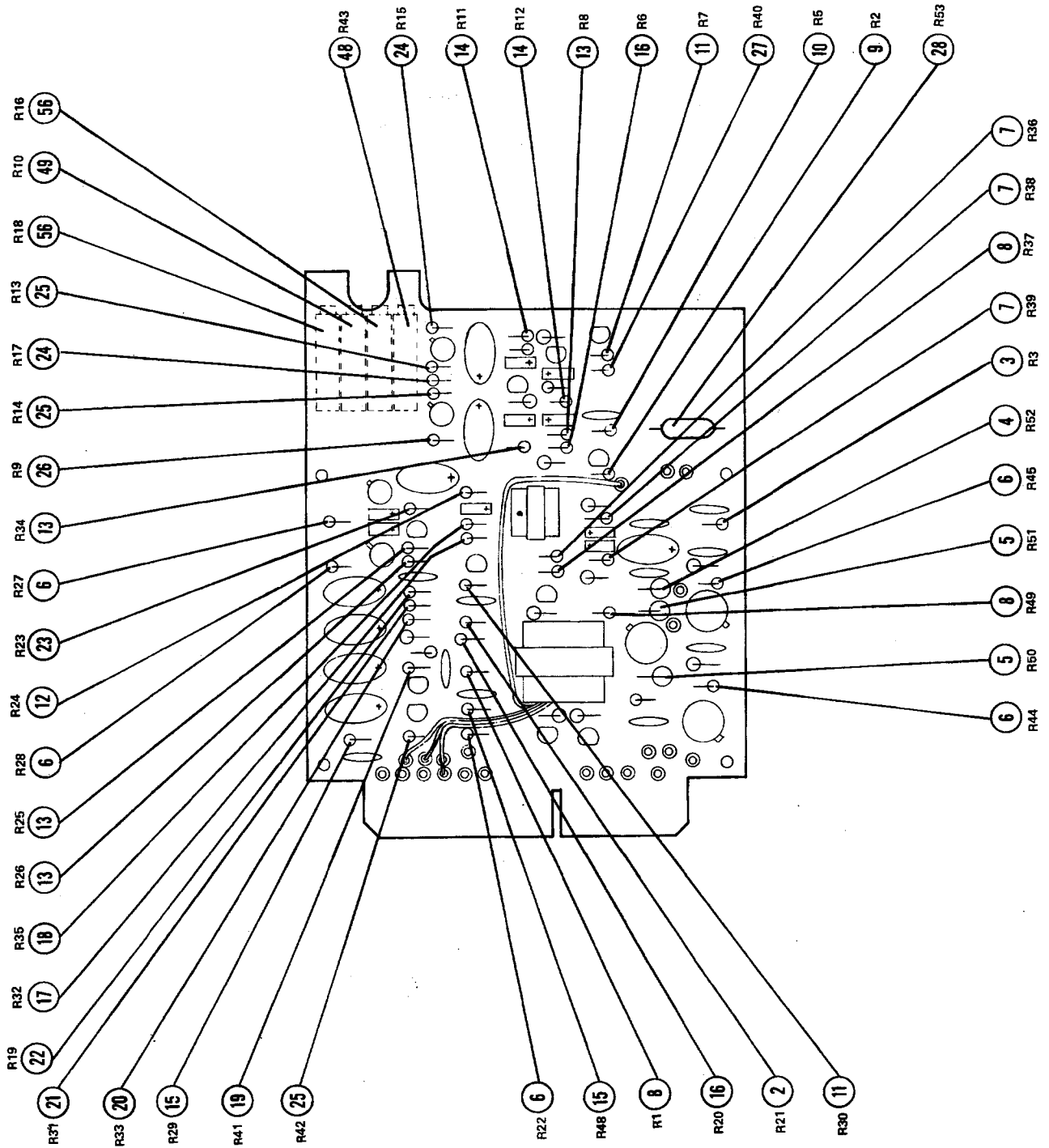

RESISTORS

FIGURE 4-1D (CON'T.)

2. Monitor roll excitation at pins B and C with oscilloscope.
3. For 14V units, vary the power supply from 12 to 15 vdc. For 28V units, vary the power supply from 24 to 30 vdc. Scope presentation should be 27 ± 1 v p-p. Transients should be less than 7 volts plus and 4 volts minus.
4. Disconnect scope.

D. Bank vs. Heading Command:

1. Set D.G. and horizon to 0. (66D141-1.)
2. Engage HDG on Console/Amplifier.
3. Set D.G. to 10° left. Roll horizon should null output at $10^{\circ} +2/ -1$ left. (Output is read on Power Section Meter.)
4. Set D.G. to 10° right. Roll horizon should null output at $10^{\circ} +2/ -1$ right. (See Fig. 4-8.)

E. Threshold Sensitivity:

1. Set D.G. and horizon to 0.
2. Null output with centering pot. (See Fig. 4-3.)
3. Adjust threshold sensitivity (left pot) full CCW.
4. Set horizon to 1° left bank. Output to Power Section should be 1.5 to 2.0 vdc. Adjust threshold sensitivity to full CW. Output should be 3.2 to 3.7 vdc on Power Section.
5. Set threshold sensitivity to produce 2V. Reverse horizon to 1° right. Output should be $2V \pm .2$.

F. Bank Limiting:

1. Set left and right bank adjustments on the console to minimum limit (CCW). (See Fig. 4.3.)
2. Set D.G. to 45° left. No more than 15° left horizon shall be required to null output on Power Section. (See Fig. 4-8.)
3. Set D.G. to 45° right. No more than 15° right horizon shall be required to null output.
4. Set left and right bank adjustments on the console to maximum limit (CW).
5. Leave D.G. at 45° right. No less than 24° right horizon should be required to null output.
6. Set D.G. to 45° left. No less than 24° left horizon should be required to null output.
7. Set bank adjustments so 20° left and right horizon will produce a null output with 45° of left and right D.G. input.
8. Set D.G. to 0.

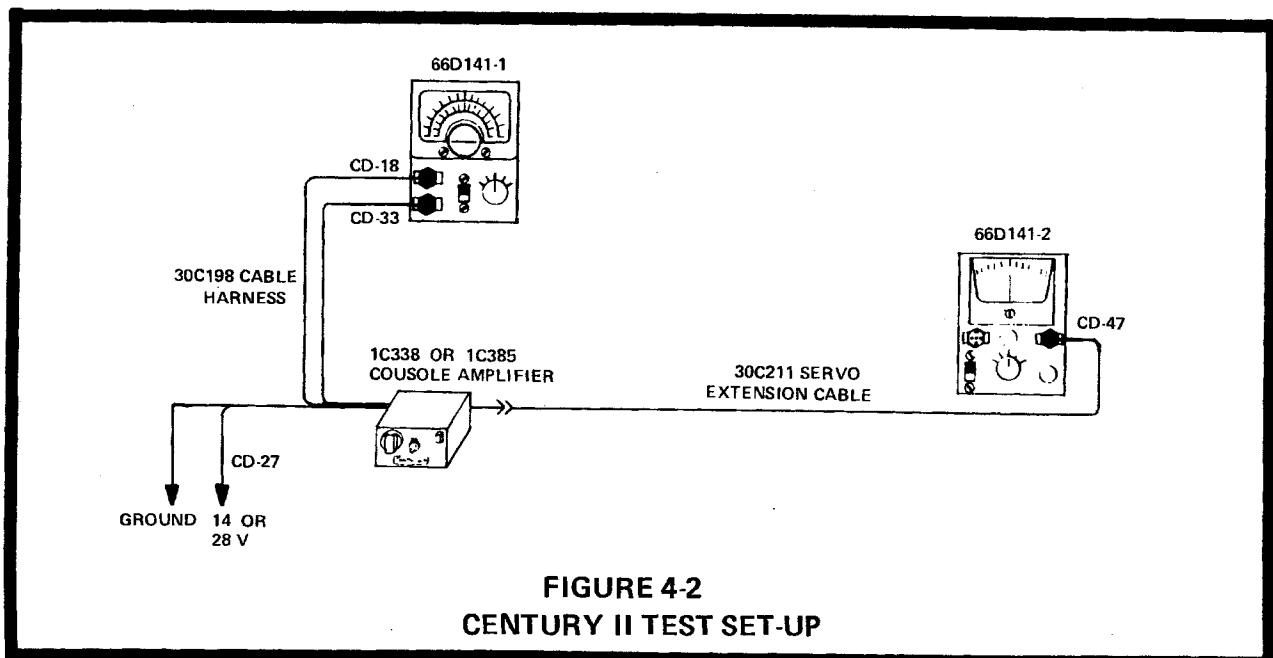

**FIGURE 4-2
CENTURY II TEST SET-UP**

G. Trim Range:

1. Turn centering pot to full CW. Null output with horizon vernier. Record setting.
2. Turn centering pot to full CCW. Null output with horizon vernier. The difference between the two settings should be 6° or more.
3. Set horizon to 0 and null output with centering pot.

H. Manual Bank Limiting:

1. Push HDG Switch off.
2. Turn Command Knob full CW. Horizon should not exceed 30° right to null output.
3. Turn Command Knob full CCW. Horizon should not exceed 30° left to null output.
(See Fig. 4-8.)

NOTE: Bank limiting must be set at 20° in HDG mode.

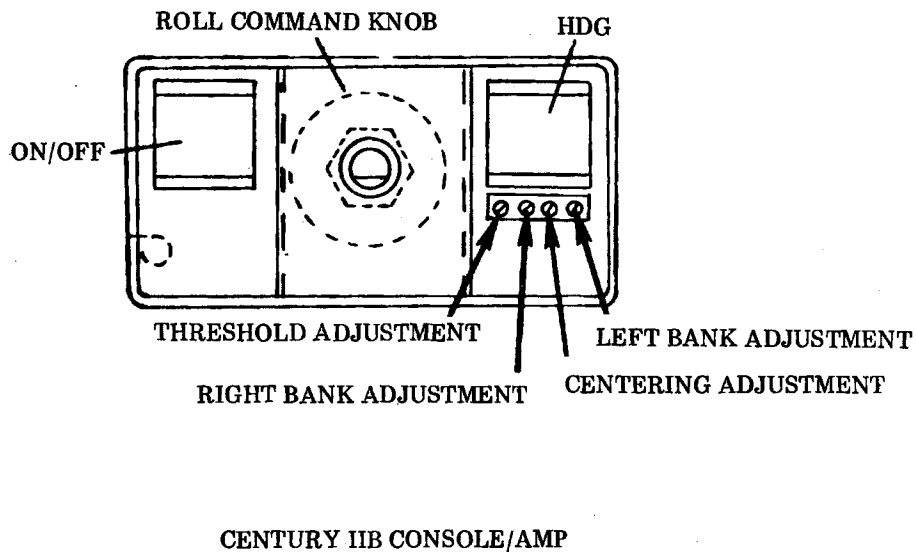
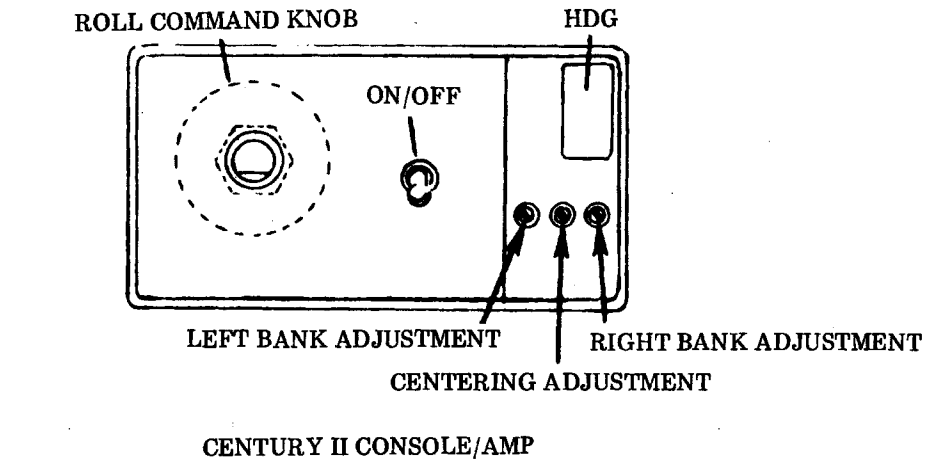

FIGURE 4-3
CENTURY II & IIB CONSOLE ADJUSTMENT

4.3 1D395, 1C515 AND 1C515-1 & -2 CENTURY III AMPLIFIERS

4.3.1 Theory (1D395 Amplifier) - Aircraft supply voltage enters the amplifier on Pin N of the amplifier plug (Refer to Fig. 4-4). A+ (14V or 28V) is applied to the primary centertap of T-1 and T-2. It is also applied to a voltage regulator on the plate of the amplifier that supplies a regulated reference voltage to the oscillator. The regulator consists of CR-1, Q-26 and voltage divider network R-64 and R-66. Switch S-1 adjusts for 14V or 28V input. The regulator is set by CR-1 to produce an output 11 volts below the A+ input level. This is 11 volts below 14 volts in a 14 volt system or 11 volts below 28 volts in a 28 volt system. The reference voltage is applied to the emitter junction of the oscillator transistors Q-22 and Q-23. The combination of a series resonant circuit in the Directional Gyro with C-31 and R-60 in the amplifier form a resonant circuit that tunes the oscillator to be 5khz.

The secondaries of T-1 provide Roll and Pitch excitation and the input to a square wave amplifier Q-24 and Q-25 known as the driven oscillator. The amplifier output (T-2) supplies the roll and pitch phase detectors with referenced A. C. and roll and pitch supply which is rectified to provide D. C. to the roll and pitch circuits.

The roll section begins with the DG signal switch. This switch consists of Q-1 which controls the bias on Q-2. In the HDG mode, Q-1 is off and Q-2 acts as a normal A. C. amplifier to the DG signal across R-1 and applies it to the first synchronous filter.

In the Roll mode there is a D. C. path through R-2 to the roll command pot in the console. Current flow through R-67 and R-2 will cause Q-1 to conduct. The voltage developed across R-3 drives Q-2 into saturation blocking the D. G. signal. The roll command signal is applied to the first synchronous filter through C-6 and R-65.

The first synchronous filter will introduce bank angle limiting by limiting the maximum left or right command signals individually (Heading or Roll modes).

The output of the first filter across R-11 is summed with the roll signal from the Artificial Horizon at the junction of R-11 and R-12. This composite signal is amplified by Q-5 and fed to the second synchronous filter through R-16.

The second synchronous filter introduces feedback from an analog circuit (often called the electronic follow-up) takes the place of a control surface follow-up element on a short term basis. The diodes simulate the lost motion inherent in the servo motor drive as it responds to the amplifier output.

One diode conducts when the output of the servo amplifier reaches about 3 volts (the amount required to start the servo motor). A feed-back signal from the diodes is applied across C-8, an integrating element, to the synchronous filter. Feedback increases as C-8 charges reducing the signal across Q-6 and Q-7. The output of Q-6 and Q-7 is amplified by Q-8 and transformer coupled to the roll phase detector. Refer to paragraph 4.11 and 4.12 for a detailed description of synchronous filters and phase detectors.

The output of the phase detector is a D. C. signal of a polarity and amplitude proportional to the input. This D. C. signal is applied to the roll servo motor amplifier, completing the roll portion of the amplifier.

NOTES: The effect of the follow-up diodes can be seen graphically at the output of the pitch or roll phase detectors. With an oscilloscope set on 2V/cm vertical deflection monitor the output of the phase detector while slowly rotating the command knob around the center. The signal will move rapidly between about 4 volts positive and negative. Beyond these points, the output will rise more slowly as feed-back is introduced.

For the pitch channel, mode switch is accomplished in the console. Either the Pitch Command signal or the Altitude signal will enter the amplifier on pin 15. Q-12 amplifies the signal and applies it to the first synchronous filter. From the collector of Q-13 to the collector of Q-14 there is a lag network made up of C-20 and diodes CR-16 and CR-17. The diodes conduct with about .7 volts across them so small signals will not be affected by the lag capacitor C-20. With a larger signal the diodes conduct. As C-20 charges the output of the synchronous filter will rise slowly in the direction of the input. This slowly changing output will eliminate rapid pitch command changes. Pitch limiting is also applied to the bases of the synchronous filter.

The output of the first filter is summed with Artificial Horizon pitch signal at the junction of R-40 and R-41.

Q-15 will amplify the resultant signal and apply it to the second synchronous filter (Q-16 and Q-17). The second filter introduces the follow-up signal at the collector of Q-17. The pitch feed-back signal is developed in the same manner as the roll feed-back. C-36 and R-45 is a noise filter.

Q-18 will amplify and transformer couple the signal to the pitch phase detector. The phase detector and servo amplifier are the same as the roll section.

4.3.2 Theory (1C515 Amplifier) - The 1C515 Amplifier is essentially the same as a 1D395 amplifier. In the 1C515 amplifier, an extra circuit board is added to basic 1D395 amplifier board. This piggyback board contains Roll and Pitch Rate circuits and a Lag Filter across the roll command synchronous filter. See Fig. 4-5.

Only these additional circuits will be discussed for the 1C515 amplifier. Refer to the 1D395 Amplifier Theory, paragraph 4.3.1 for the basic circuit operation.

The first change in the 1C515 is the addition of the Lag Filter across the collectors of the first synchronous filter Q-3 and Q-4. Refer to page 4-55 paragraph 4-10 for a detailed discussion of synchronous filters.

At points 12 and 13 on the amplifier board, the voltage across the collectors of the first synchronous filter (Q-3 and Q-4) is brought out to the piggy-back board and applied across the Lag Filter. At the moment of a right roll command, Q-18 will be forward biased and C-22 will begin to charge. As C-22 charges, the output of the synchronous filter rises slowly and reaches the commanded input when C-22 is fully charged. Q-17 will be reverse biased until the polarity is reversed during a left command. When a left command is initiated, C-22 will quickly discharge through the now forward biased diode CR-5. Q-17 and C-21 will cause a smooth left command in the same manner as Q-18 and C-22 regardless of the rate of the commanded input.

The command signal from the first filter is summed with the horizon signal at the junction of R-11 and R-12 (Fig. 4-5). Before this junction (at Point 9) a portion of the horizon signal is brought out to the piggy-back board for the Roll Rate Circuit. When the autopilot is initially turned on, the horizon position signal (from Point 9) is amplified by Q-1 on the piggy-back board and applied to the first rate circuit synchronous filter Q-2 and Q-3. Notice the phase reversal across Q-1.

Q-2 and Q-3 will filter the noise from the horizon signal. From this filter the signal is applied across R-7 to the base of emitter-follower Q-6. The emitter of Q-6 drives amplifiers Q-7 and Q-8.

Q-7 is a high gain amplifier. It will reverse the phase of the signal from Q-1 and the first synchronous filter Q-4 and Q-5. Placed across the collectors of the second filter is a lag capacitor C-7. As C-7 charges the output of the second filter will rise to the level of the input from Q-7. The output of the second filter is applied across R-8 and is out of phase with the signal from the first filter. The two signals are summed between R-7 and R-8. Q-7, being a very high gain amplifier, can drive the resulting signal at the summing point between R-7 and R-8 to a very low level (less than 50 mv) after C-7 charges. This condition will be maintained for any steady-state horizon signal.

From the emitter of Q-6 the signal is also applied to Q-8. The output of Q-8 is applied back to the amplifier board (Point 11) for any steady-state signal the output of Q-8 is just enough to bring the horizon signal back up to its input level.

When the horizon signal changes, an error signal is developed at the summing point of the two synchronous filters. The lag capacitor C-7 will cause the signal across the second synchronous filter to change slower than the input signal. This causes an error signal between R-7 and R-8 which is proportional to, and in a direction adding to the changing position signal. The error signal represents the rate of change in the position signal.

The rate signal from the emitter of Q-6 is amplified by Q-8. From Q-8, the rate signal is added to the position signal on the amplifier board (through Point 11). The autopilot senses not only the position signal but the rate of any change in the position signal.

The pitch signal has a similar circuit on the piggy-back board. The output resistors are different because pitch has a higher rate signal than roll.

4.3.3 Theory (1C515-1 & -2 Amplifier) - The 1C515-1 and -2 amplifiers are basically the same as the 1C515 amplifier. The 1C515-1 amplifier incorporates all the circuitry on one board, whereas the 1C515 amplifier has a roll command lag filter and pitch and roll rate circuits on an additional circuit board. Refer to Fig. 4-6.

The only change in circuitry consists of using an adjustable feed-back circuit instead of the follow-up diodes for roll and pitch. The pitch and roll follow-up circuits are the same so only the roll circuit will be discussed.

The follow-up circuit was introduced because it can be adjusted to match the autopilot more closely with the dynamics of each aircraft. R-51 is the Threshold adjustment. Varying R-51 will change the bias on both transistors (Q-22 and Q-23) changing the level at which they will conduct, or their threshold. Q-22 (NPN) will conduct when the roll motor common is positive with respect to the roll motor. (Q-23 [PNP] is reverse biased until the polarity of the servo amplifier is reversed.) Q-22 will conduct when the output of the servo amplifier reaches approximately 3 volts, depending on the threshold adjustment. When Q-22 conducts, feed-back is introduced to Q-17 across capacitive network C-23 through C-26, decreasing the signal across the second synchronous filter and the gain of the amplifier. Q-23 will operate in the same manner for the opposite polarity output from the D.C. amplifier.

4.3.4 Century III 1D395 and 1C515 Amplifier Tests

A. Test Equipment Required:

1. 66D141 Test Set
2. Oscilloscope (H-P 120B or equivalent)
3. Regulated Power Supply

NOTE: Refer to Figures 4-5 and 4-8 as necessary.

B. Test Set Up:

1. Set voltage selectors on amplifier and test equipment to power supply voltage.
2. On Gyro Substitute, set Roll-Pitch Switch to Roll, and D. G. and Horizon to zero.
3. Connect amplifier. (See Fig. 4-7)
4. Connect CD-47 to Power Section 66D141-2. Protect CD-16 from shorts.
5. Select D. G. and ALT CONTROL on Console Substitute.
6. Limit switch to MAX.
7. Set Alt. Control to zero.
8. Null roll output to Power Section with Roll Trim Knob.
9. Turn system ON and null Power Section reading (Output) with Roll Trim.

C. Oscillator and Regulator Checks:

1. Set scope as follows:
 - (a) Sweep time to 50u sec.
 - (b) AC-DC to DC.
2. Monitor roll excitation pins B to C with scope.
3. For 14V units, vary power supply from 12 to 15 vdc. Scope presentation should be a 5 KHz square wave 28 ± 2.8 vp-p. Transients should be less than 7 volts plus or 4.2 volts minus.
4. For 28V units, vary power supply from 24V to 30 vdc. Scope presentations will be the same as for 12V units.

D. Roll-Bank vs. Heading Command:

1. Set D. G. to 10° left. Null power section (amplifier output) with horizon vernier. Roll horizon should read $10^{\circ} +2/-1$ left.
2. Set D. G. to 10° right. Roll horizon should null output at $10^{\circ} +2/-1$ right. (See Fig. 4-8).
3. Set D. G. to 45° right. Roll horizon should null output with 24° or more right roll. Record setting.
4. Set D. G. to 45° left. Roll horizon should null output with 24° more left roll. Record setting.
5. Set Limit Switch to MIN.
6. With D. G. set 45° left, 15° or less will be required to null output on Power Section.
7. Set D. G. to 45° right. 15° or less will be required to null output.
8. Set Manual D. G. Switch on Console Substitute to Manual. Set Limit Switch to MAX.
9. Set Roll Command Knob full right. 8° to 10° more horizon will be required to null output than was obtained in step 3.
10. Set Roll Command Knob full left. 8° to 10° more horizon will be required to null output than was obtained in step 4.
11. Set Manual DG Switch on Console Substitute to DG.

E. Threshold Sensitivity:

1. Set D. G. to O.
2. Set horizon vernier to produce 2 volts output on Power Section. Record Settings.
3. Set horizon vernier to produce 2 volts in the opposite direction on Power Section.
4. The total change between horizon settings should not exceed 2.5° Roll.

F. Roll Trim Range:

1. Set Roll Trim full CW and null Power Section with Gyro Substitute. Not Reading.
2. Set Roll Trim full CCW and null Power Section. The total change between these two settings should correspond to 6° Roll or more.

G. Pitch Threshold:

1. Set Gyro Substitute Roll-Pitch Switch to Pitch.
2. Turn system off and connect CD-16 in place of CD-47 on Power Section. Protect CD-47 from shorting.
3. Null output with Pitch Trim.
4. Turn system on. Set horizon vernier to produce 2V on Power Section. Record setting.
5. Set horizon vernier to produce 2V in the opposite direction on Power Section. The total change between pitch horizon settings should not exceed 1.5° .
6. Return horizon vernier to 0.

H. Altitude Check:

1. **NOTE:** The pitch channel is checked with calibrated inputs from the Altitude Control. An oscilloscope must be used to set the Altitude Control to correspond with altitude deviations of 0 and 100 feet. Set vertical input to .1v/cm. Measure altitude input on pin 15 to Motor Common pin 12, or measure from the exposed lead of R-32 to motor common.
2. Set Altitude Control to 0v.
3. Null Power Section with Pitch Trim on Console Substitute.
4. Set Altitude Control to 100 feet up. (400 mv on oscilloscope).
5. $6^{\circ} \pm 1/2$ pitch horizon setting should be required to null Power Section.
6. Set Altitude Control to 100 feet down (400 mv on oscilloscope).
7. $6^{\circ} \pm 1/2$ pitch horizon setting should be required to null Power Section.
8. Set DG and Alt. Control to zero.

I. Pitch Attitude Limits - Manual:

1. Set Altitude Control-Manual Switch to Manual.
2. Turn Pitch Command Full up.
3. 11° or more up horizon setting will be required to null Power Section.
4. Turn Pitch Command Knob full down.
5. 8° or more down horizon setting should be required to null Power Section (See Fig. 4-8).
6. Set Limit Switch to MIN.
7. 4° or less down horizon setting should be required to null Power Section.
8. Turn Pitch Command Knob full up.
9. 5° or less up horizon setting should be required to null output.
10. Center Pitch Command.

J. Trim Range:

1. Set Horizon to 0.
2. Set Limit Switch to MAX.
3. Set Pitch Trim CW; note horizon setting for null.
4. Set Pitch Trim CCW; note horizon setting for null.
5. The total change between the two settings should be 6° or more.

4.3.5 Century III 1C515-1 and 1C515-2 Amplifier Tests

A. Test Equipment Required:

1. 66D141 Test Set
2. Oscilloscope (H-P 120B or equivalent)
3. Regulated Power Supply

B. Test Set Up:

1. Set voltage selectors on Test Kit and amplifier to the power supply voltage.
2. Connect the amplifier and 66D141 Test Set as shown in Fig. 4-7.
3. On the Gyro Substitute set Roll-Pitch Switch to Roll; set D. G. and Horizon to 0.
4. Set Power Section 66D141-2 to AMP-RES position.
5. Connect CR-47 to Power Section 66D141-2. Protect CD-16 from shorts.
6. Set D. G. and Alt. Control on Console Substitute.
7. Set Limit Switch to MAX.
8. Set Altitude Control to zero.
9. Turn system on and null power section reading (output) with Roll Trim.

NOTE: Refer to Figures 4-6 and 4-8 as necessary during the following checks.

C. Oscillator and Regulator Checks:

1. Set scope as follows:
 - (a) Sweep time to 50u seconds.
 - (b) Vertical input to 10 volts/cm
 - (c) AC-DC to D. C.
2. Monitor Roll excitation pins B to C with scope.
3. Roll excitation should be a $27 + 1v -p 5$ KHz square wave. Transients shall be less than 7.0V plus and 4.0Vminus.
4. For 14V units, vary the power supply from 12 to 15 vdc. For 28V units, vary the power supply from 24 to 30 vdc. Roll excitation should remain within tolerance.

D. Roll bank vs. Heading Command:

1. Set D. G. to 10° left. Null Power Section (amplifier output) with horizon vernier. Roll horizon should null output at $10^{\circ} \pm 1^{\circ}$ left.
2. Set D. G. to 10° right. Roll horizon should null output at $10^{\circ} \pm 1^{\circ}$ right.
3. Set D. G. to 45° right. Roll horizon should null output at 24° or more right roll. Record setting.
4. Set D. G. to 45° left. Roll horizon should null output at 24° or more left. Record setting.
5. Set DG-Manual Switch to Manual.
6. Command full left. Roll horizon should null output at 8° to 10° more than obtained in step 3.
7. Command full right. Roll horizon should null output at 8° to 10° more than obtained in step 4.
8. Set DG-Manual Switch to DG.
9. Set Limit Switch to MIN. Leave D. G. at 45° left. Roll horizon should null output at 15° or less.
10. Set D. G. to 45° right. Roll horizon should null output at 15° or less. Return Limit Switch to MAX.

E. Roll Lag:

1. Monitor the signal at the junction of C-2 and C-3 with an oscilloscope.
2. Set D. G. to 45° right. Typical time for the signal to reach 4vp-p is 10 seconds. The time is not critical.
3. Set D. G. to 0 and allow signal to null.
4. Set D. G. to 45° left. The time lag should be within 20% of the time lag for the right side.
5. Set D. G. to 0.

F. Roll Trim Range:

1. Set Roll Trim full CW and null output with Horizon Substitute. Note reading.
2. Set Roll Trim full CCW and null output. The total change between the two settings should be 6° or more.

G. Threshold Sensitivity:

1. Set D. G. and roll horizon to 0. Set trim for null output.
2. Set horizon to 1° right.
3. Turn Roll threshold full CW. Roll servo voltage shall be $3.2 v + .5v /-0v$.
4. Turn roll threshold CCW. Servo voltage should be $1.5v + 0/-0.5v$.
5. Adjust pot for 2V.
6. Set horizon to 1° left. Servo voltage should be $2v \pm .2$.

7. Set horizon to 0.
8. Disconnect CD-47 and connect CD-16. Protect CD-47 from shorting.

H. Pitch Threshold Sensitivity:

1. Set Gyro Substitute Roll-Pitch Switch to Pitch.
2. Check Altitude Control set at zero.
3. Null output with Pitch Trim.
4. Set Pitch Horizon up 1° .
5. Turn Pitch threshold full CW. Servo voltage should be $5v +5/0$.
6. Turn Pitch threshold full CCW. Servo voltage should be $2.5v +0/-5$.
7. Adjust threshold for 3V.
8. Set Pitch horizon 10° down. Servo voltage should be $3V \pm .3$.

I. Command vs. Gyro Inputs:

NOTE: The pitch channel is checked with calibrated inputs from the Altitude Control. An oscilloscope must be used to set the Altitude Control to correspond to altitude deviations of 0, 100', 250' or maximum. Set vertical input to .1v/cm. Measure Altitude Control input on R-60 to Pitch Motor Common on emitter of Q-28.

1. Check. Altitude Control input is 0.
2. With horizon set at 0° pitch, null output with Pitch Trim.
3. Set Altitude Control to correspond to 100 feet up (400 mv). $6^{\circ} +1/2$ of up horizon should be required to null the output. (See Fig. 4-9).
4. Set Altitude Control to correspond to 100 feet down (400mv). $6^{\circ} +1/2$ of down horizon should be required to null the output.

NOTE: For 1C515-2 amplifiers, R-60 is a set value (12K) and should not be selected.

5. Set the Altitude Control-Manual Switch to manual.
6. Turn Pitch command full up. 12° or more pitch horizon should be required to null the output.
7. Turn Pitch command full down. 8° or more pitch horizon should be required to null the output.
8. Set Limit Switch to MIN.
9. With Pitch command full down. 5° or less horizon should be required to null the output.
10. Turn Pitch command full up. 5° or less horizon should be required to null the output.
11. Null Pitch Command.

J. Trim Range:

1. Set Limit Switch to MAX.
2. Turn Pitch Trim full CW. Null output with horizon and record setting.
3. Turn Pitch Trim full CCW. Null output with horizon. The difference between the two settings should be 6° or more.

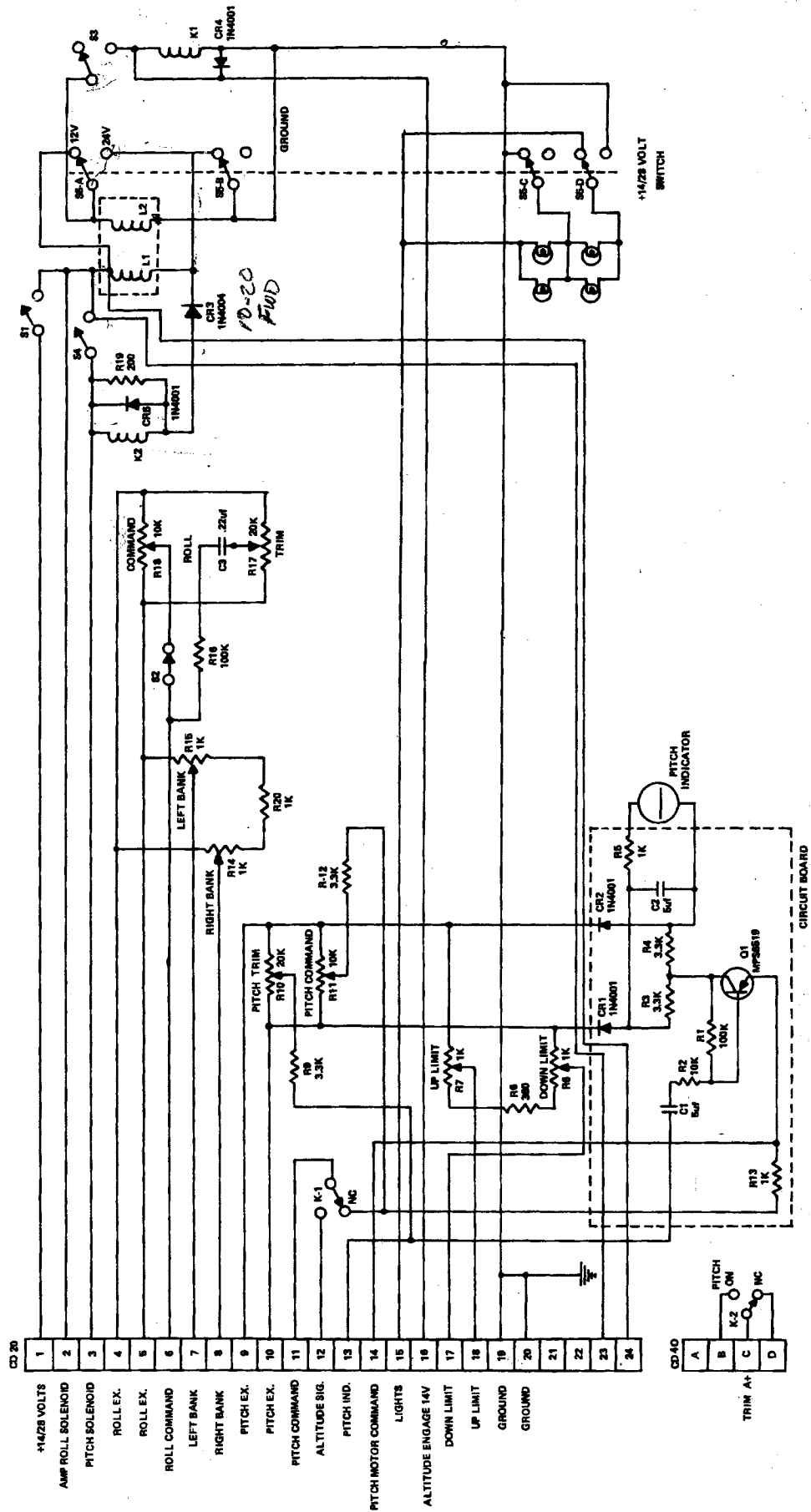
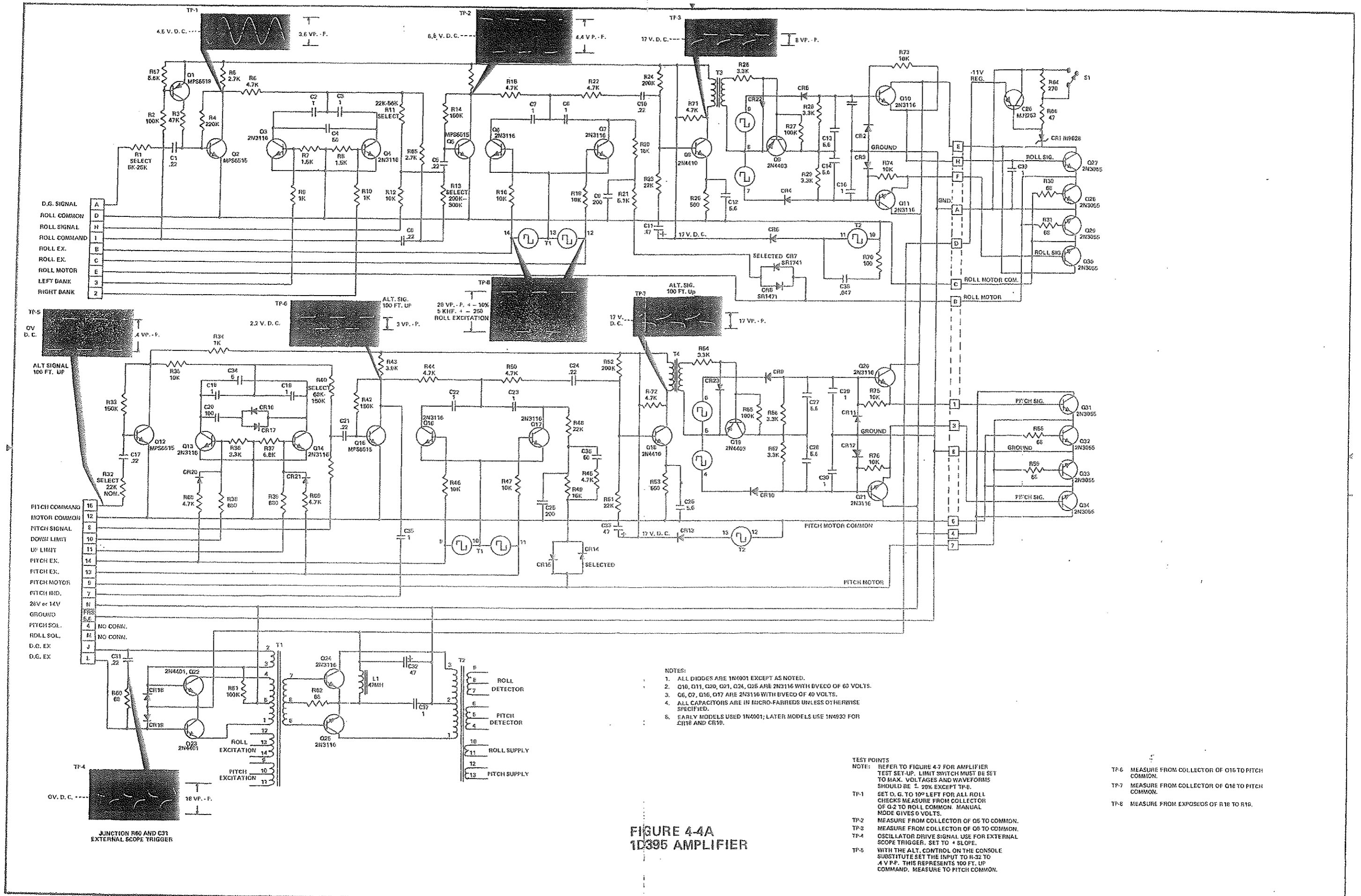

FIGURE 4-4
CENTURY III CONSOLE SCHEMATIC



- NOTES:
1. ALL DIODES ARE 1N4001 EXCEPT AS NOTED.
 2. Q10, Q11, Q20, Q21, Q24, Q25 ARE 2N3116 WITH BVCEO OF 60 VOLTS.
 3. Q6, Q7, Q16, Q17 ARE 2N3116 WITH BVCEO OF 40 VOLTS.
 4. ALL CAPACITORS ARE IN MICRO-FARREDS UNLESS OTHERWISE SPECIFIED.
 5. EARLY MODELS USED 1N4001; LATER MODELS USE 1N4933 FOR CR18 AND CR19.

- TEST POINTS
- NOTE: REFER TO FIGURE 4-7 FOR AMPLIFIER TEST SET-UP. LIMIT SWITCH MUST BE SET TO MAX. VOLTAGES AND WAVEFORMS SHOULD BE $\pm 20\%$ EXCEPT TP-8.
- TP-1 SET D. G. TO 10° LEFT FOR ALL ROLL CHECKS MEASURE FROM COLLECTOR OF Q-2 TO ROLL COMMON. MANUAL MODE GIVES 0 VOLTS.
 - TP-2 MEASURE FROM COLLECTOR OF Q5 TO COMMON.
 - TP-3 MEASURE FROM COLLECTOR OF Q8 TO COMMON.
 - TP-4 OSCILLATOR DRIVE SIGNAL USE FOR EXTERNAL SCOPE TRIGGER. SET TO 4 SLOPE.
 - TP-5 WITH THE ALT. CONTROL ON THE CONSOLE SUBSTITUTE SET THE INPUT TO R-32 TO 4 V P.P. THIS REPRESENTS 100 FT. UP COMMAND. MEASURE TO PITCH COMMON.

- TP-6 MEASURE FROM COLLECTOR OF Q15 TO PITCH COMMON.
- TP-7 MEASURE FROM COLLECTOR OF Q16 TO PITCH COMMON.
- TP-8 MEASURE FROM EXPOSEDS OF R18 TO R19.

FIGURE 4-4A
1D395 AMPLIFIER

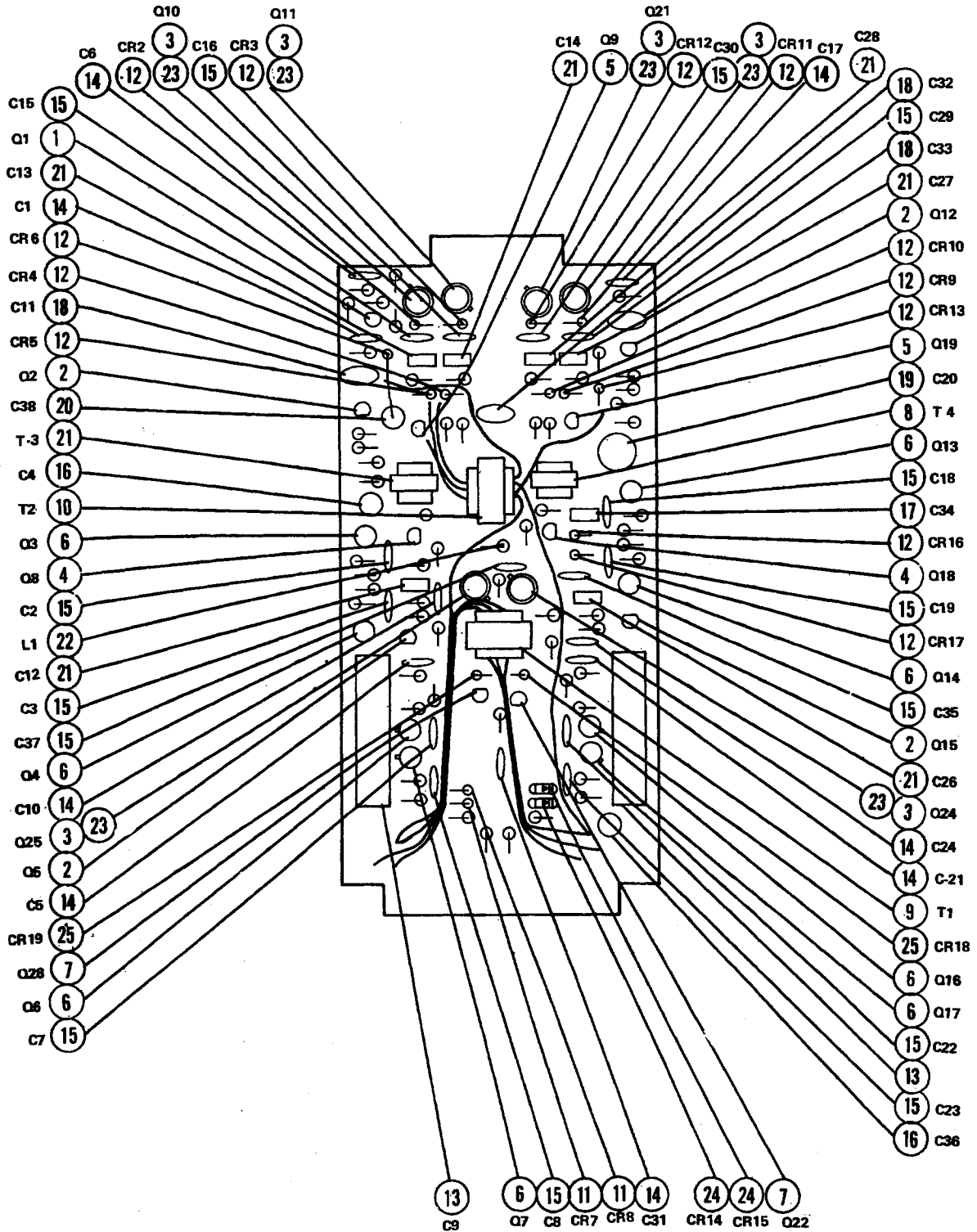

FIGURE 4-4B

1D395 AMPLIFIER CIRCUIT BOARD

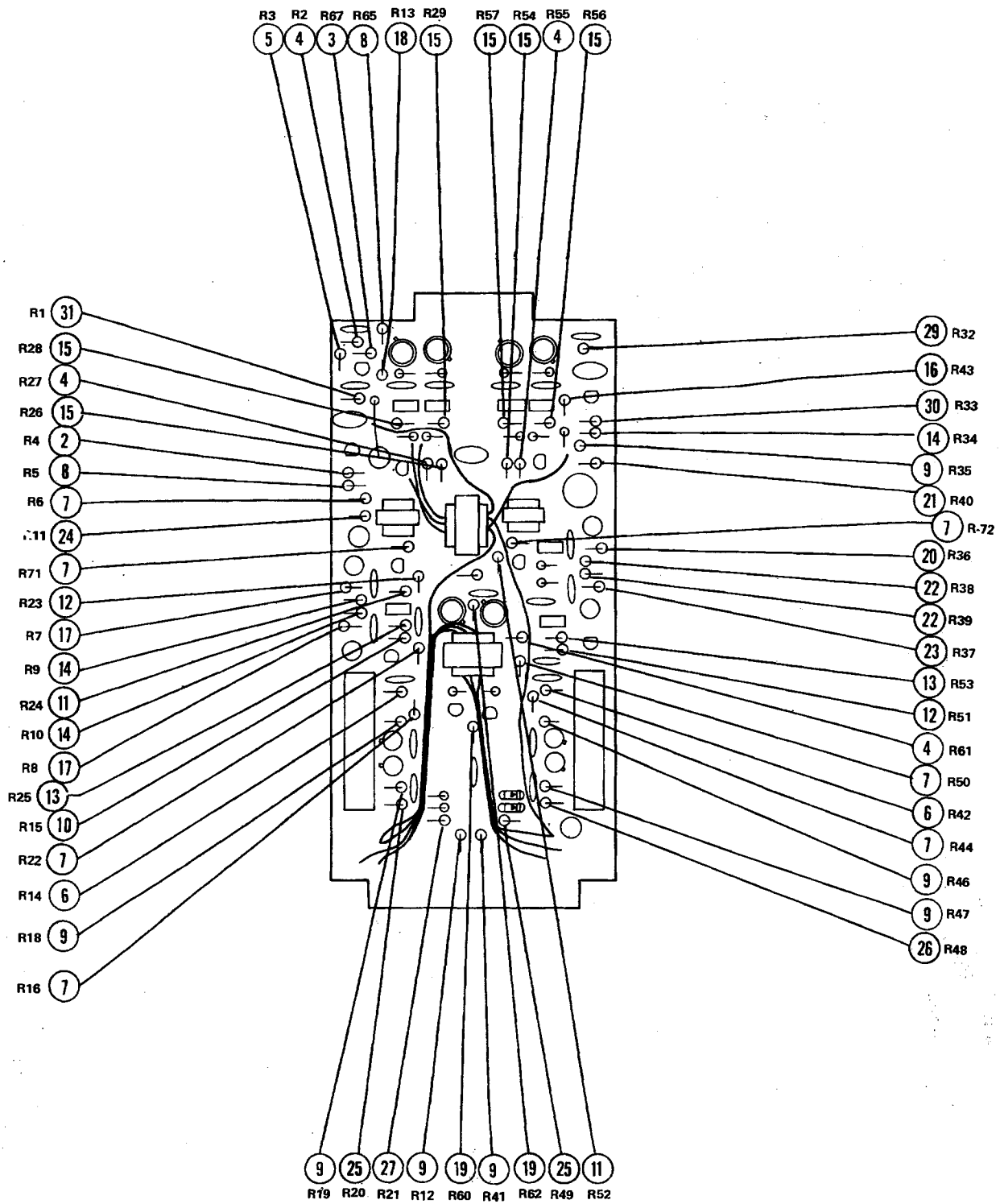

FIGURE 4-4B CON'T.

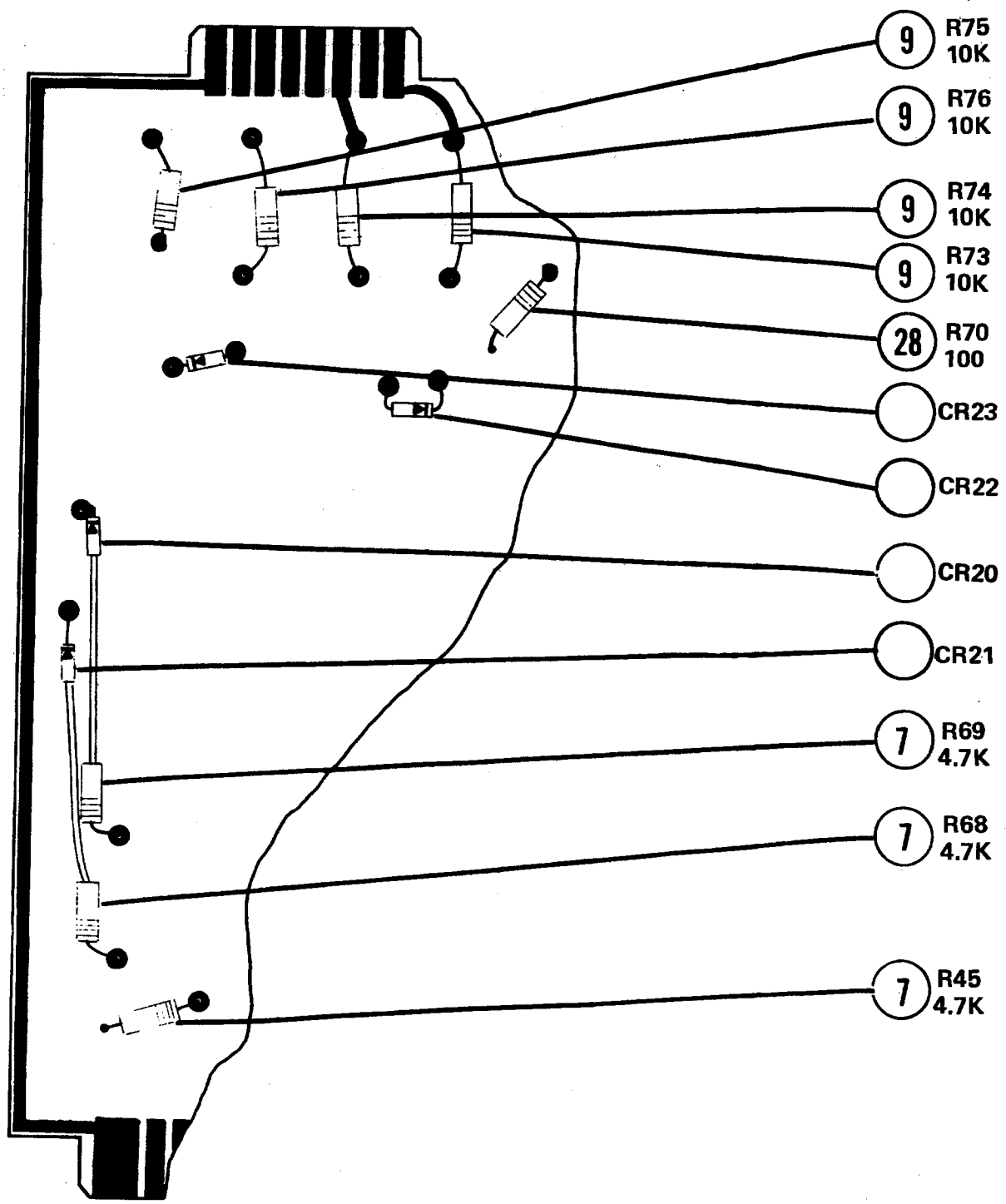

FIGURE 4-4B CON'T.

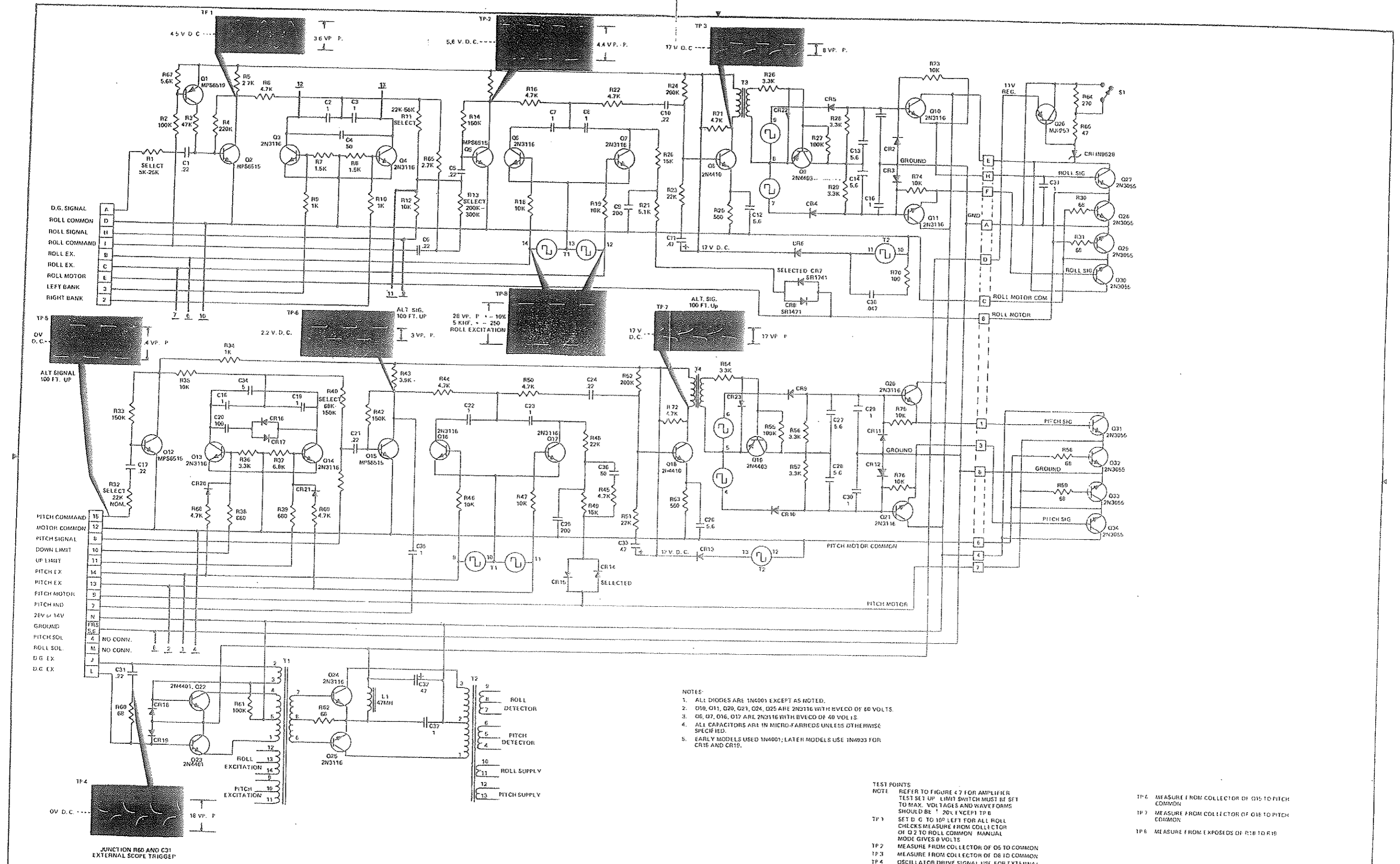
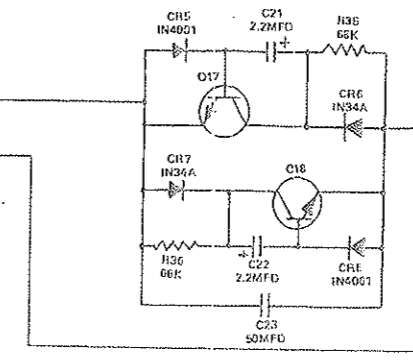
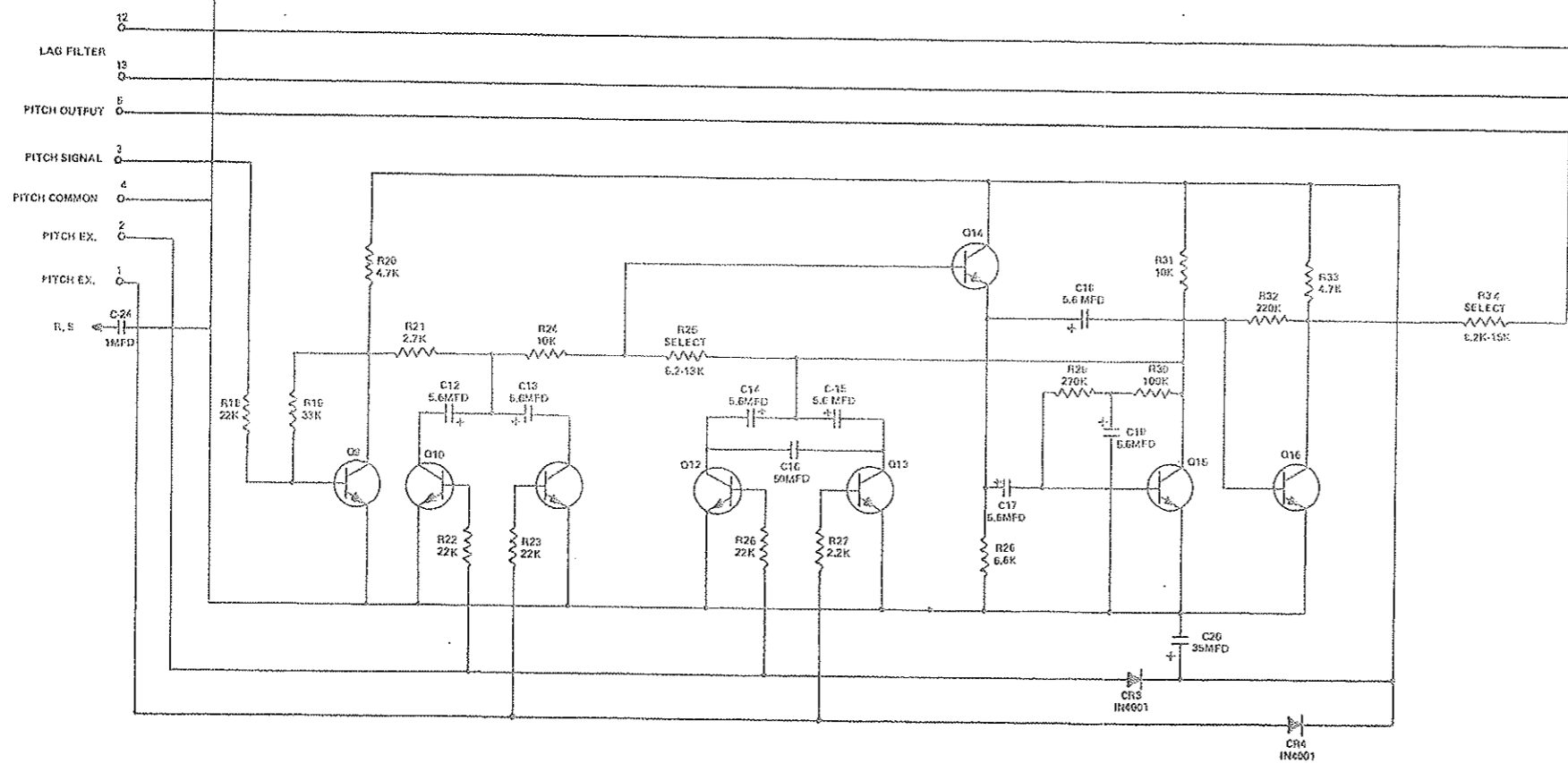
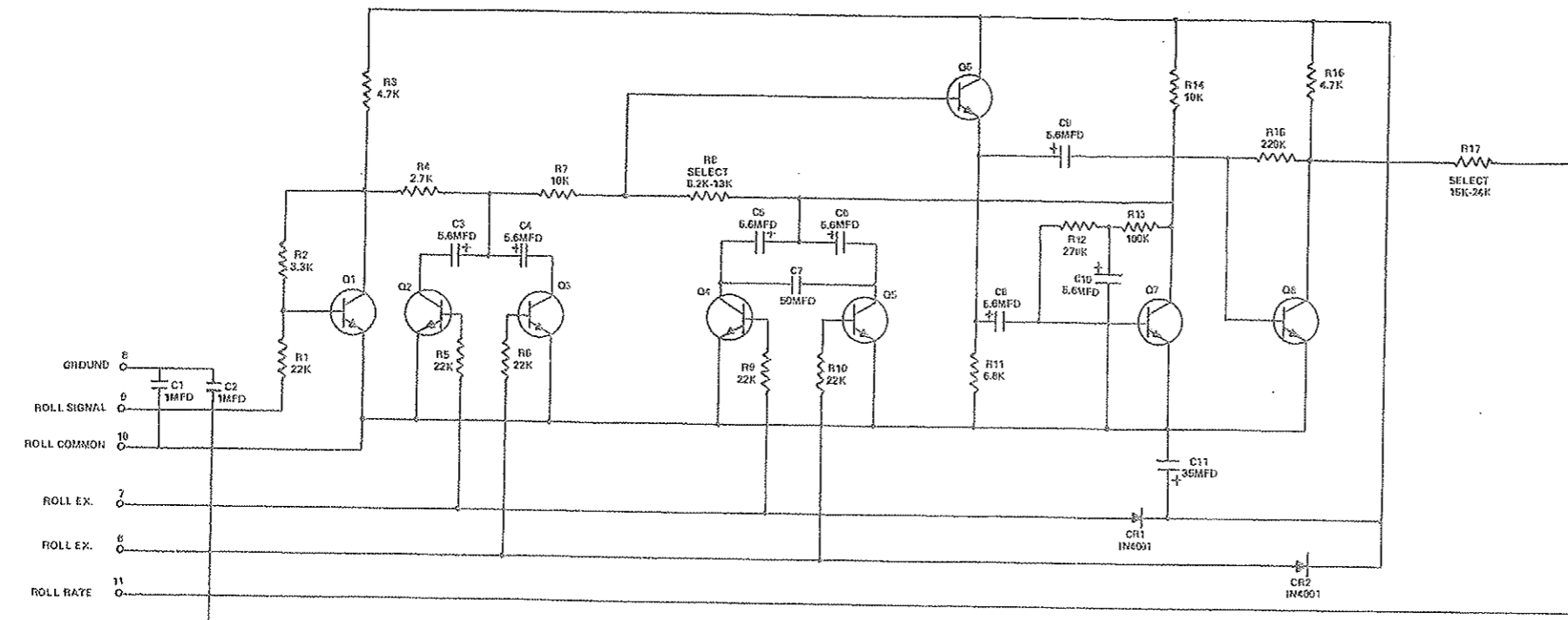

FIGURE 4-5A
1C515 AMPLIFIER



- NOTES:
1. ALL TRANSISTORS ARE MP8551
 2. REV. 1 (63D174)
 3. REFER TO 1C515 AMPLIFIER SCHEMATIC

FIGURE 4-5A Cont:
1C515 AMPLIFIER

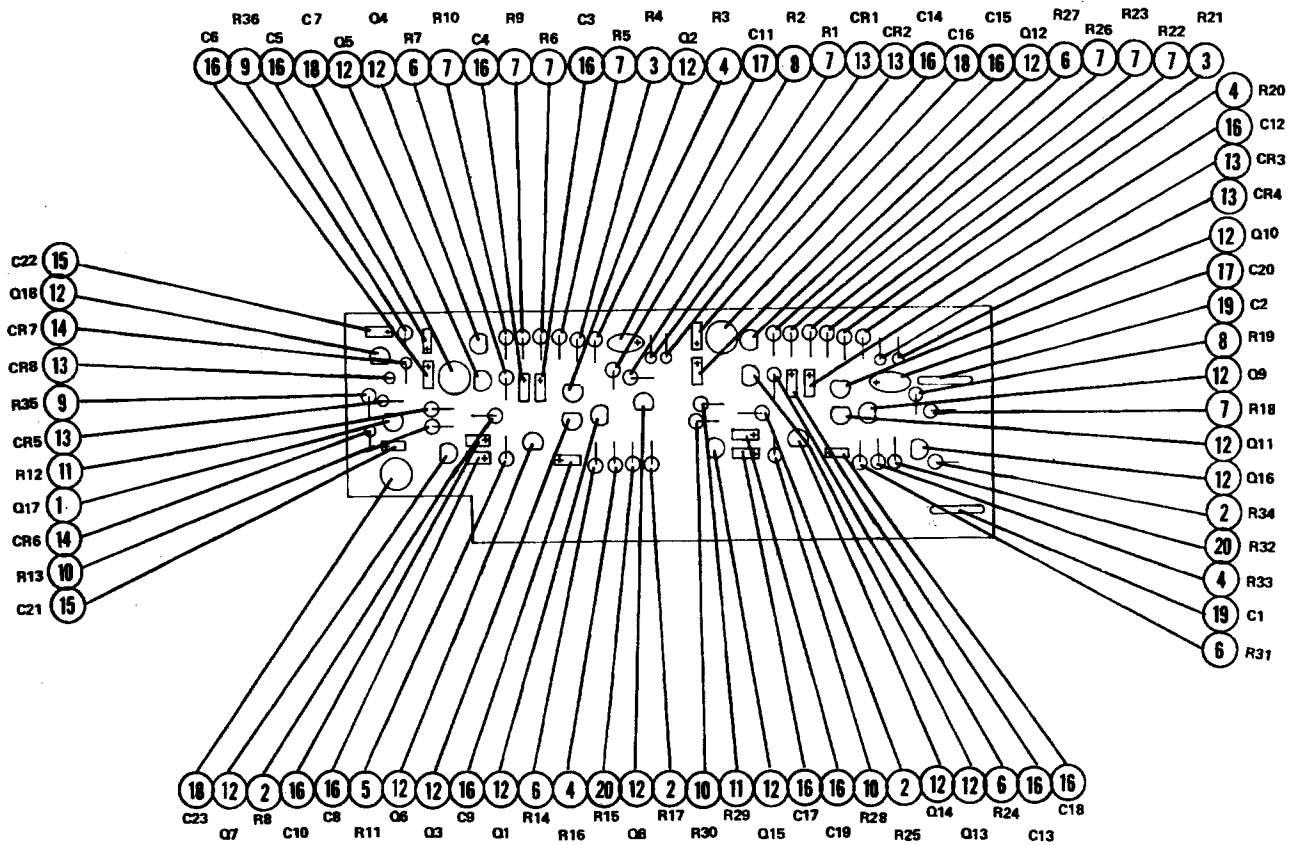
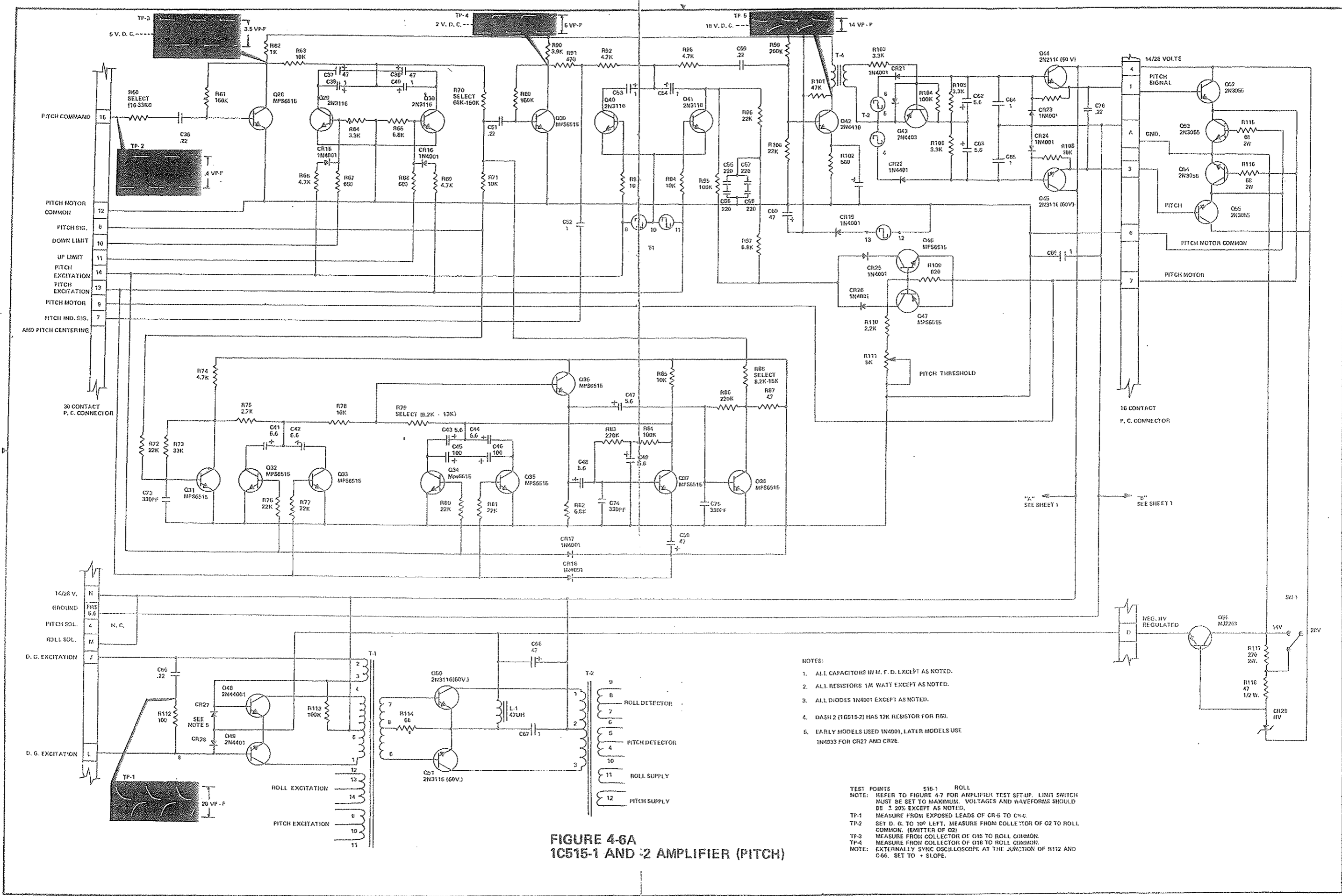

FIGURE 4-5B

1C515 AMPLIFIER CIRCUIT BOARD

(RATE BOARD ONLY - AMPLIFIER SAME AS FIGURE 4-4B)



**FIGURE 4-6A
1C515-1 AND -2 AMPLIFIER (PITCH)**

- NOTES:**
1. ALL CAPACITORS IN M. F. D. EXCEPT AS NOTED.
 2. ALL RESISTORS 1/4 WATT EXCEPT AS NOTED.
 3. ALL DIODES 1N4001 EXCEPT AS NOTED.
 4. DASH 2 (16S15Z) HAS 12K RESISTOR FOR R53.
 5. EARLY MODELS USED 1N4001, LATER MODELS USE 1N4933 FOR CR27 AND CR28.

TEST POINTS 515-1 ROLL
NOTE: REFER TO FIGURE 4-7 FOR AMPLIFIER TEST SET-UP. LIMIT SWITCH MUST BE SET TO MAXIMUM. VOLTAGES AND WAVEFORMS SHOULD BE ± 20% EXCEPT AS NOTED.
 TP-1 MEASURE FROM EXPOSED LEADS OF CR-5 TO CR-6.
 TP-2 SET D. G. TO 10° LEFT, MEASURE FROM COLLECTOR OF Q2 TO ROLL COMMON. (EMITTER OF Q2)
 TP-3 MEASURE FROM COLLECTOR OF Q15 TO ROLL COMMON.
 TP-4 MEASURE FROM COLLECTOR OF Q16 TO ROLL COMMON.
NOTE: EXTERNALLY SYNC OSCILLOSCOPE AT THE JUNCTION OF R112 AND C-66. SET TO + SLOPE.

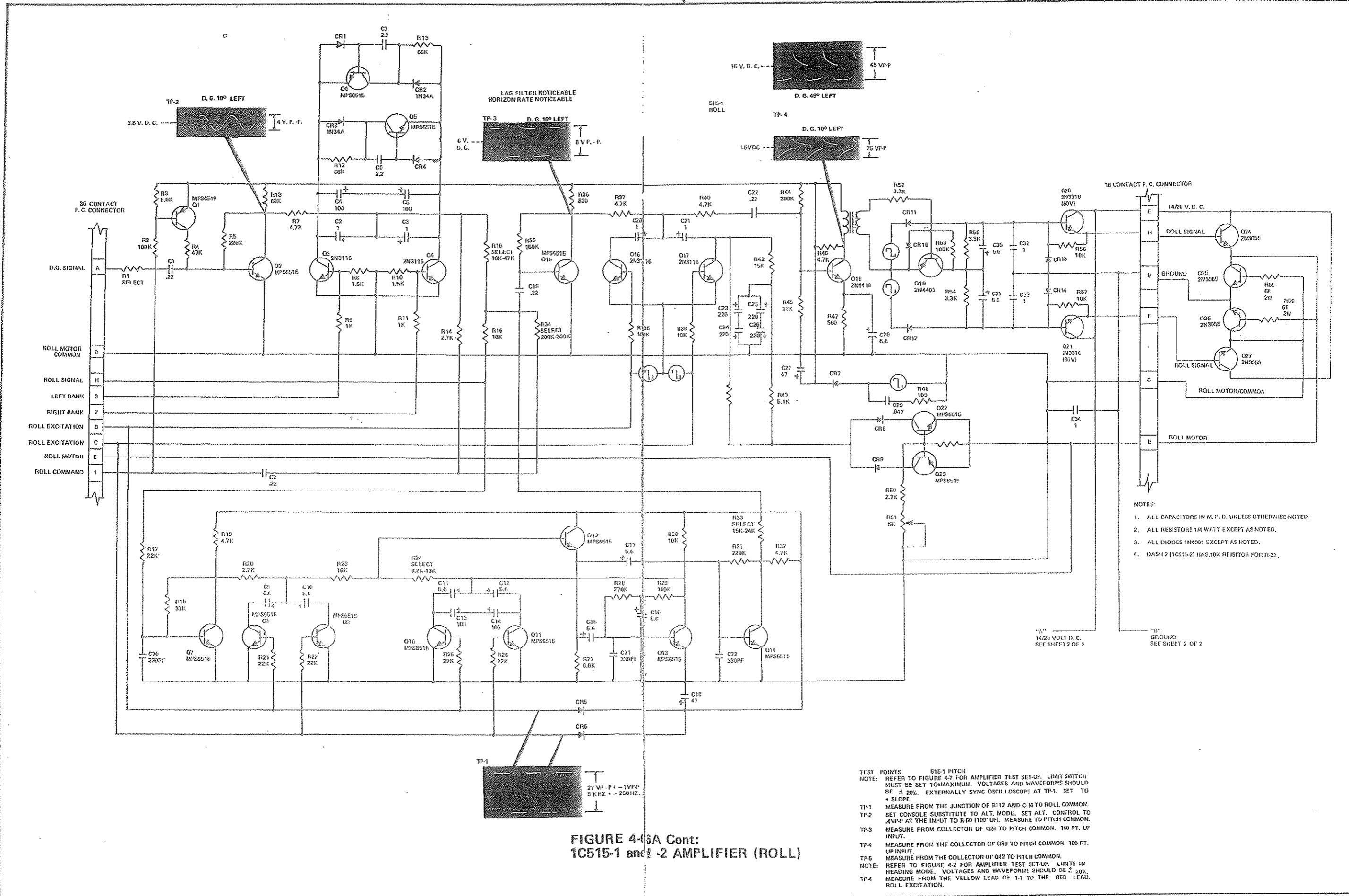

- NOTES:
1. ALL CAPACITORS IN M. F. D. UNLESS OTHERWISE NOTED.
 2. ALL RESISTORS 1/4 WATT EXCEPT AS NOTED.
 3. ALL DIODES 1N4001 EXCEPT AS NOTED.
 4. DASH 2 (1C515-2) HAS 10K RESISTOR FOR R-33.

- TEST POINTS 615-1 PITCH
- NOTE: REFER TO FIGURE 4-7 FOR AMPLIFIER TEST SET-UP. LIMIT SWITCH MUST BE SET TO MAXIMUM. VOLTAGES AND WAVEFORMS SHOULD BE $\pm 20\%$. EXTERNALLY SYNC OSCILLOSCOPE AT TP-1, SET TO + SLOPE.
- TP-1 MEASURE FROM THE JUNCTION OF R112 AND C-16 TO ROLL COMMON.
 - TP-2 SET CONSOLE SUBSTITUTE TO ALT. MOD. SET ALT. CONTROL TO 4VP-P AT THE INPUT TO R-60 (100' UP). MEASURE TO PITCH COMMON.
 - TP-3 MEASURE FROM COLLECTOR OF Q28 TO PITCH COMMON. 100 FT. UP INPUT.
 - TP-4 MEASURE FROM THE COLLECTOR OF Q39 TO PITCH COMMON. 100 FT. UP INPUT.
 - TP-5 MEASURE FROM THE COLLECTOR OF Q42 TO PITCH COMMON.
- NOTE: REFER TO FIGURE 4-2 FOR AMPLIFIER TEST SET-UP. LIMITS IN HEADING MODE. VOLTAGES AND WAVEFORMS SHOULD BE $\pm 20\%$. MEASURE FROM THE YELLOW LEAD OF T-1 TO THE RED LEAD. ROLL EXCITATION.

FIGURE 4-25A Cont:
1C515-1 and -2 AMPLIFIER (ROLL)

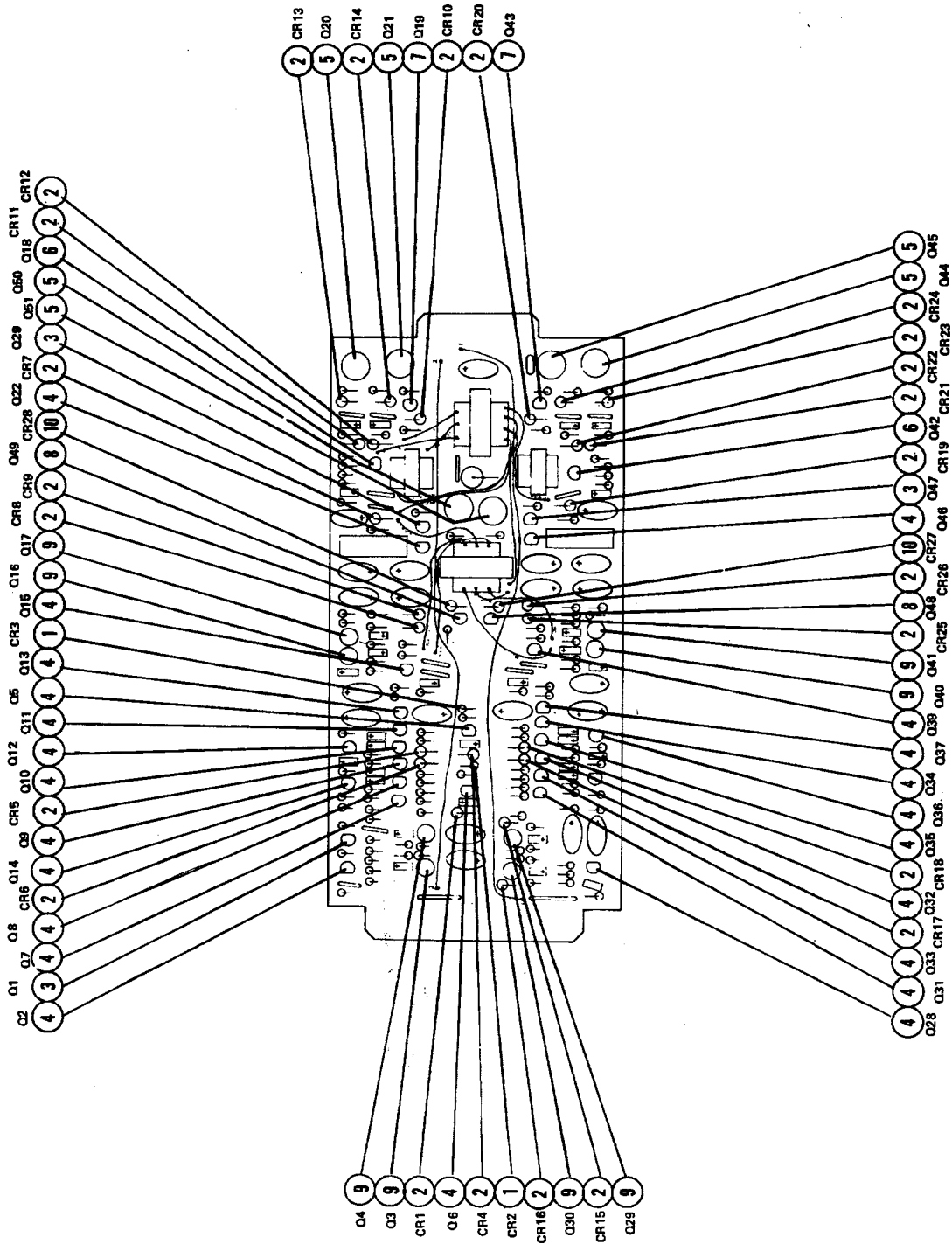

TRANSISTORS & DIODES

FIGURE 4-6B

1C515-1 & 2 AMPLIFIER CIRCUIT BOARD

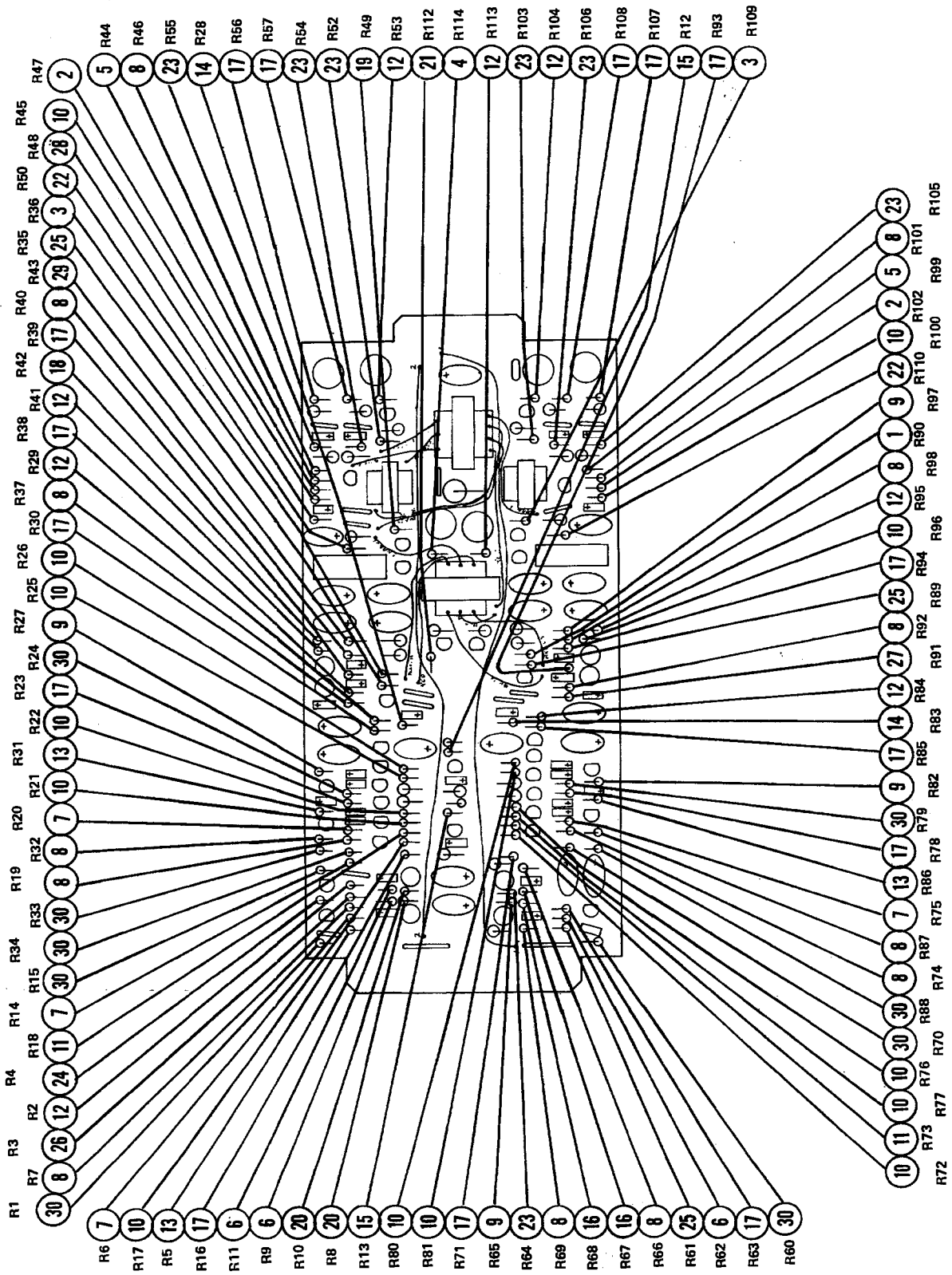

RESISTORS

FIGURE 4-6B (CONT.)

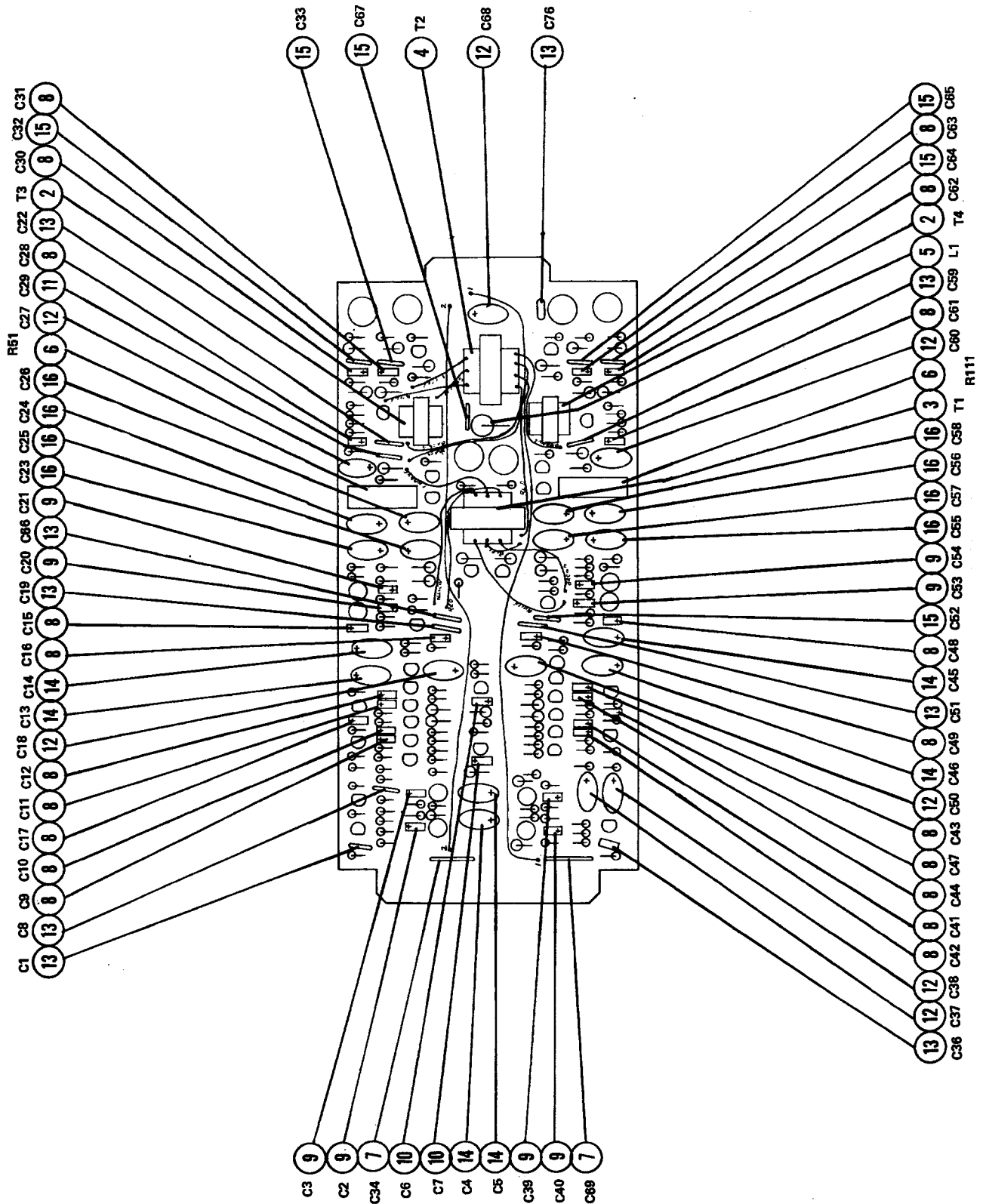

CAPACITORS & TRANSFORMERS

FIGURE 4-6B (CON'T.)

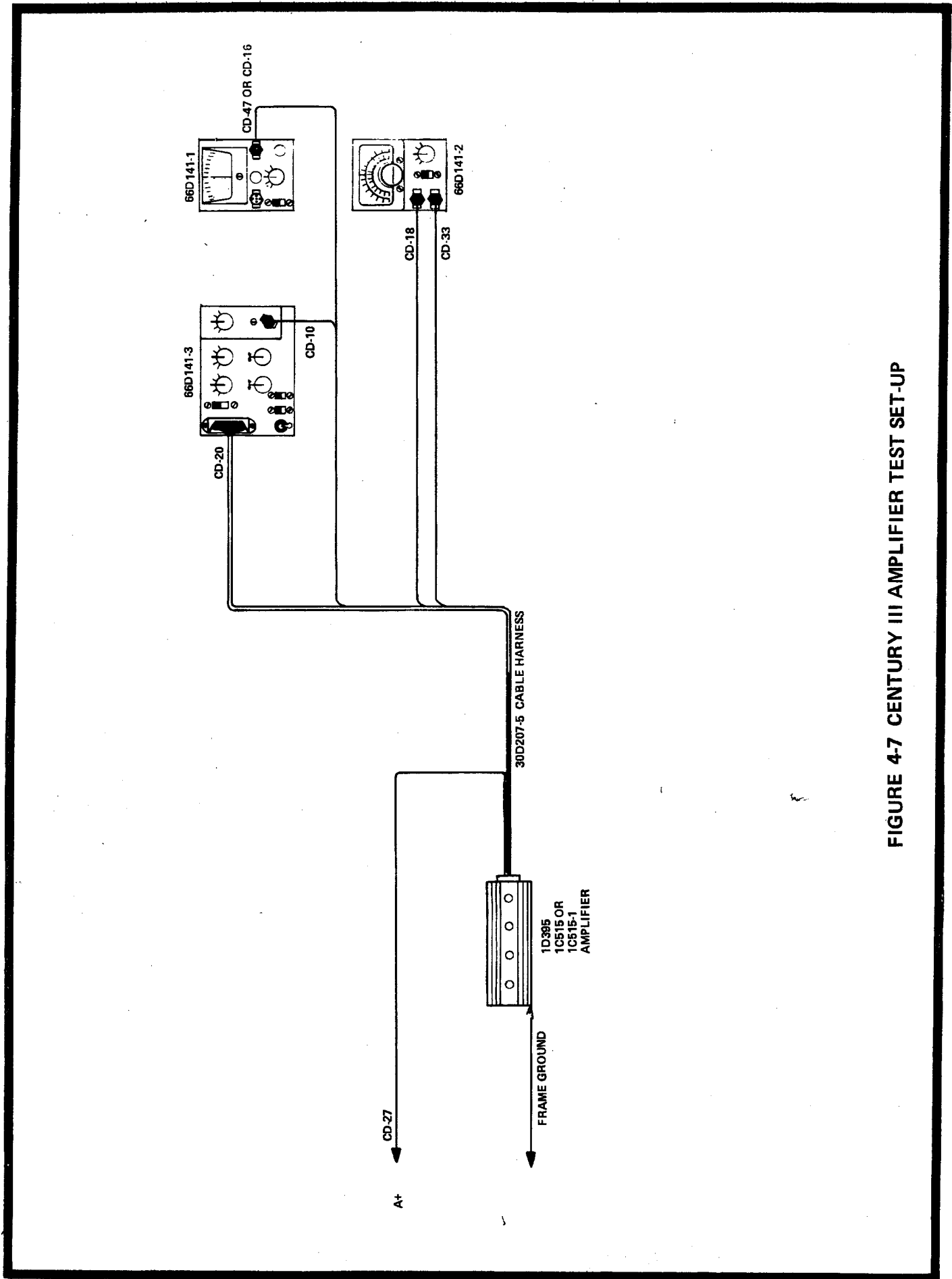

FIGURE 4-7 CENTURY III AMPLIFIER TEST SET-UP

CENTURY III					
1C395 and 1C515			1C515-1 and 1C515-2		
Resistor	Value	Reference	Resistor	Value	Reference
R-1	5K to 25K	Paragraph 4.3.4D Steps 1,2	R-1	4.7K to 24K	Paragraph 4.3.5D Steps 1,2
R-11	22K to 56K	Paragraph 4.3.4D Steps 4, through 7	R-15	10K to 47K	Paragraph 4.3.5D Steps 3,4,7,10
R-13	200K to 300K	Paragraph 4.3.4D Steps 8 through 10	R-34	200K to 300K	Paragraph 4.3.5D Steps 5,6,7
R-32	5K to 25K 22K nominal	Paragraph 4.3.4H Steps 2 through 7	R-60	515-1(10Kto33K 515-2 (12K)	Paragraph 4.3.5I Steps 3,4
R-40	68K to 150K	Paragraph 4.3.4I Steps 3 through 5	R-70	68K to 150K	Paragraph 4.3.5I Steps 6 through 10
CENTURY II AND IIB					
CENTURY II 1C385			CENTURY IIB 1C385		
Resistor	Value	Reference	Resistor	Value	Reference
R-1	4.7K to 20K	Paragraph 4.2.2D Steps 3,4	R-3	4.7K to 20K	Paragraph 4.2.3D Steps 3,4
R-15	22K to 56K	Paragraph 4.2.2F Steps 2 through 6	R-19	270K to 390K	Paragraph 4.2.3H Steps 1,2,3
			R-21	22K to 56K	Paragraph 4.2.3F Steps 2 through 6
<p>Under certain conditions, select resistors may have to be changed to bring the performance of an amplifier within specifications. Select resistors are used to set the gain or limiting for a particular stage. For example: R-1 in a 1D395 amplifier is selected to cause a 10° bank angle when the DG is offset 10° (left or right). The value of R-1 would be increased if both bank angles were high (13° to 15°) but only if they were the same. If the left and right banks are uneven, look for an imbalance in the circuit.</p> <p>Use the Select Resistor Chart,(Fig. 4-8) corresponding to the amplifier being tested as a guide in bringing the amplifier within tolerance when no problem can be found in the circuitry. Each resistor in the chart is referenced to corresponding steps in the check-out procedure.</p>					

FIGURE 4-8
SELECTOR RESISTOR CHART

4.4 ROLL SIGNAL FILTER

The Roll Signal Filter is a "Rate" circuit that plugs in line with the Artificial Horizon. Its purpose is to tell the amplifier "how fast" the aircraft is rolling in one direction or the other.

The pitch signal from the horizon passes directly through the filter. A steady state roll signal is filtered and sent out of the filter at the same amplitude and phase as the input. A changing roll signal will be altered in proportion to the rate of roll.

The roll signal centers the filter on pin C (See Fig. 4-9) and is amplified and phase reversed by Q-1. A 1vp-p square wave on pin C will result in approximately 1.3vp-p at the collector at Q-1. This signal will be seen at the top of the first synchronous filter Q-2 and Q-3.

Q-2 and Q-3 filter the noise from the horizon signal. From this filter the signal is applied across R-7 to the base of emitter-follower Q-8. The emitter of Q-8 drives amplifiers Q-6 and Q-7. Q-6 is a high gain amplifier. It will again reverse the phase of the signal from Q-1 and the first synchronous filter.

The output of Q-6 is applied to the second synchronous filter Q-4 and Q-5. Placed across the collectors of the second filter is a lag capacitor C-4. As C-4 charges, the output of the second filter rises to the level of the input from Q-6.

The output of the second filter is applied across R-9. It is out of phase with the signal from the first filter and will subtract from that signal between R-7 and R-9. Q-6, being a very high gain amplifier, drives the resulting signal at the summing point between R-7 and R-9 to a very low level (less than 50mv) after C-4 charges. This condition is maintained for any steady state horizon signal.

From the emitter of Q-8 the signal is summed with the signal from the first filter at R-8 R-13, and rate adjustment pot R-19. Between R-8 and R-13 the signal is applied to the base of Q-8 through C-6. Q-7 is the output amplifier to the autopilot amplifier. The output should be equal to the input for any steady state horizon signal.

When the horizon signal changes an error signal is developed at the summing point of the two synchronous filters. The lag capacitor C-4 will cause the signal across the second synchronous filter to change slower than the input signal. This causes an error signal between R-7 and R-9. The error signal is proportional too, and in a direction adding to the changing position signal. It represents the rate of change in the position signal. This error or rate signal is applied to the base of Q-8. From the emitter of Q-8 it will be summed with position signal through R-19 and R-13. The combination of position and rate is amplified by Q-7 and sent to the amplifier.

Because R-19 will also have an effect on the amplitude of the position signal, re-check the bank limits after adjusting R-19.

NOTE: Adjusting the Roll Signal Filter is outlined in Section VI of this manual.

NOTE: Roll Signal filters serial numbers 1405 and below used P-N-P instead of N-P-N transistors. In these units, the supply voltage is reversed. (See Fig. 4-9 Note 3).

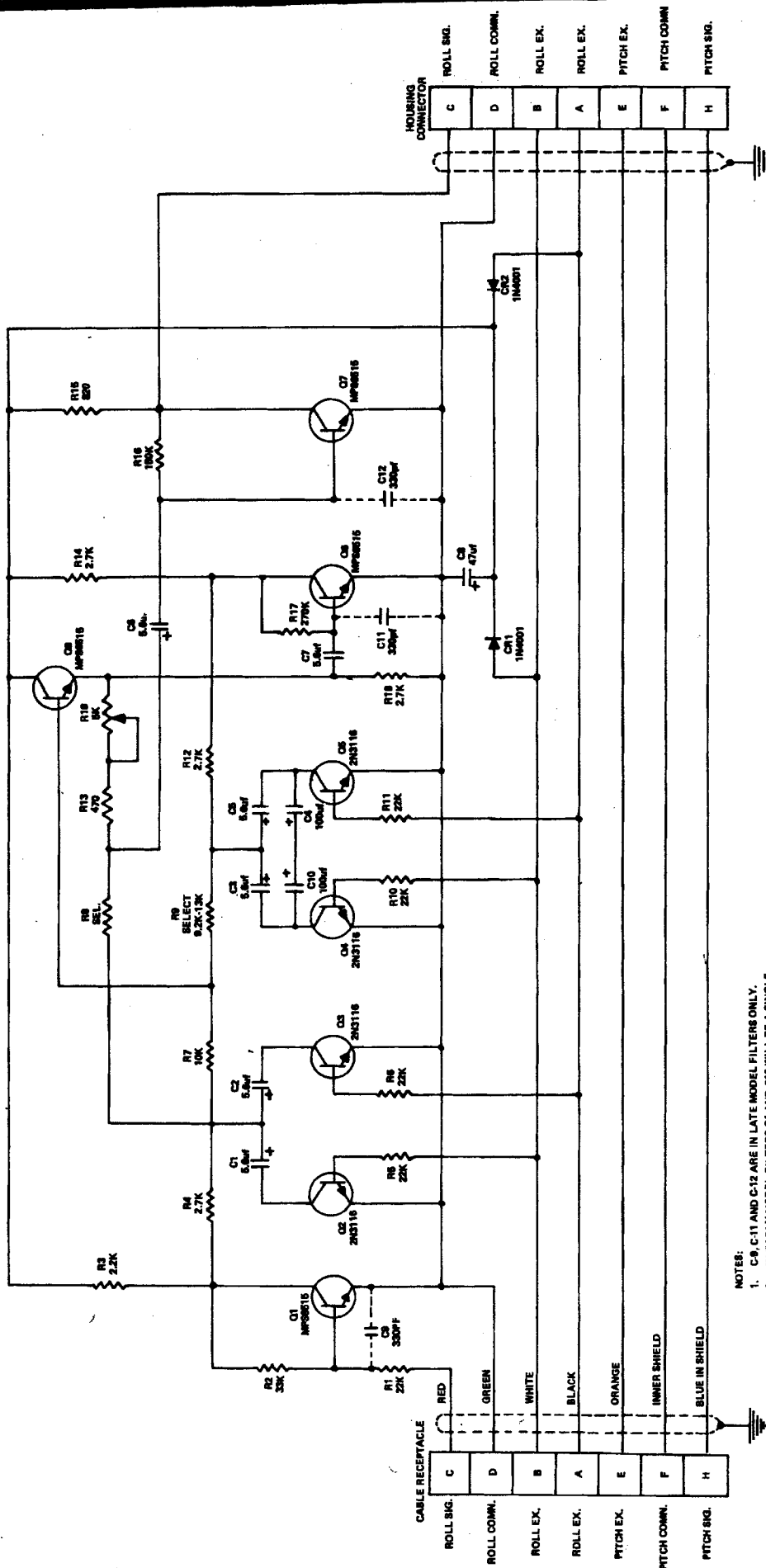

- NOTES:
1. C9, C11 AND C12 ARE IN LATE MODEL FILTERS ONLY.
 2. IN EARLY MODEL FILTERS Q4 AND C10 WILL BE A SINGLE 50MΩ NON-POLARIZED CAPACITOR.
 3. EARLY FILTERS USED P-N-P INSTEAD OF N-P-N TRANSISTORS.
- THE CHANGES ARE AS FOLLOWS:
- A. Q1, Q-6, Q-7, Q-8 ARE MP9618.
 - B. Q2, Q-3, Q-4, Q-5 ARE 1M4001.
 - C. CR-1 AND CR-2 WILL BE REVERSED.

FIGURE 4-9A
ROLL SIGNAL FILTER
1B440 SCHEMATIC

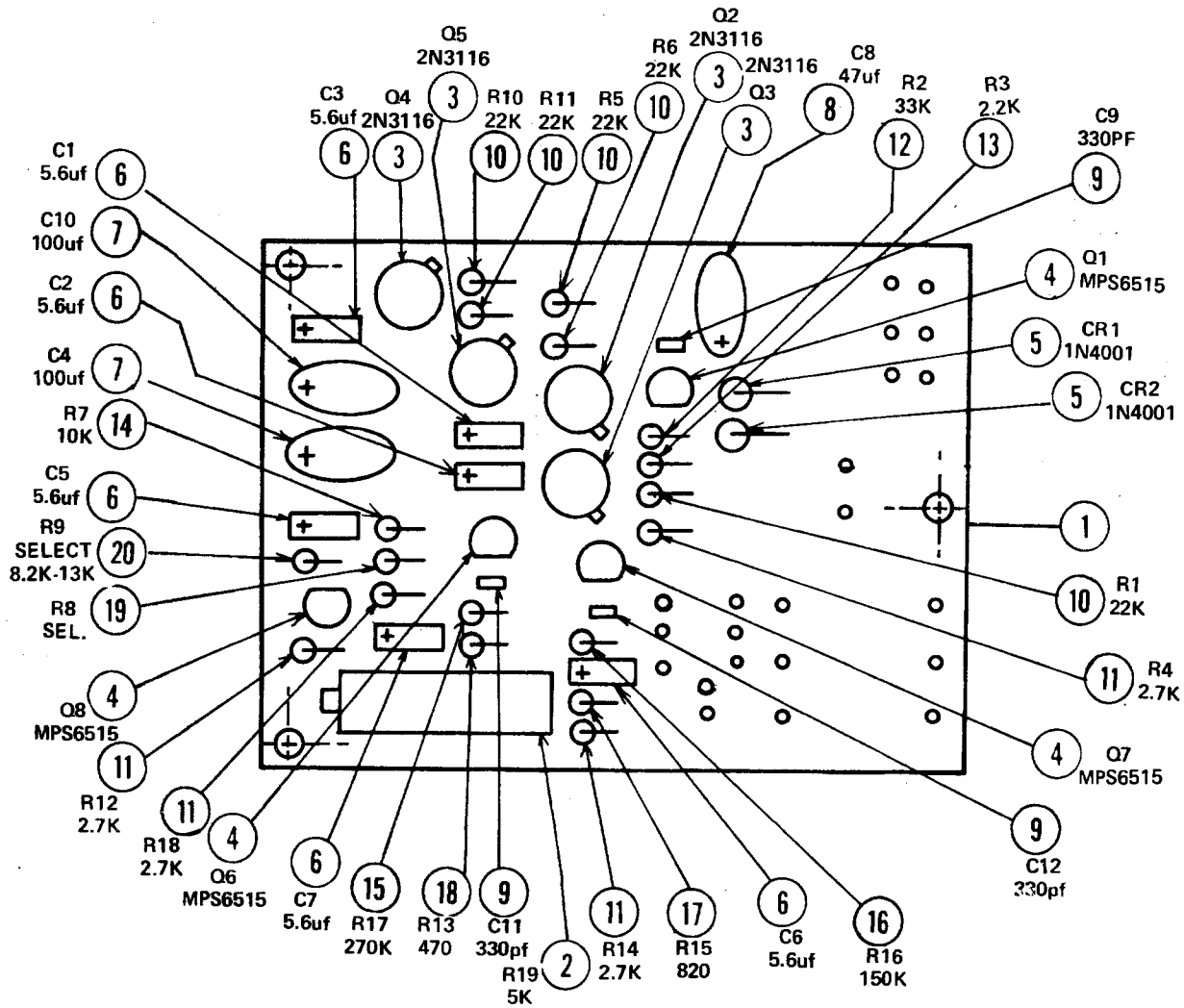
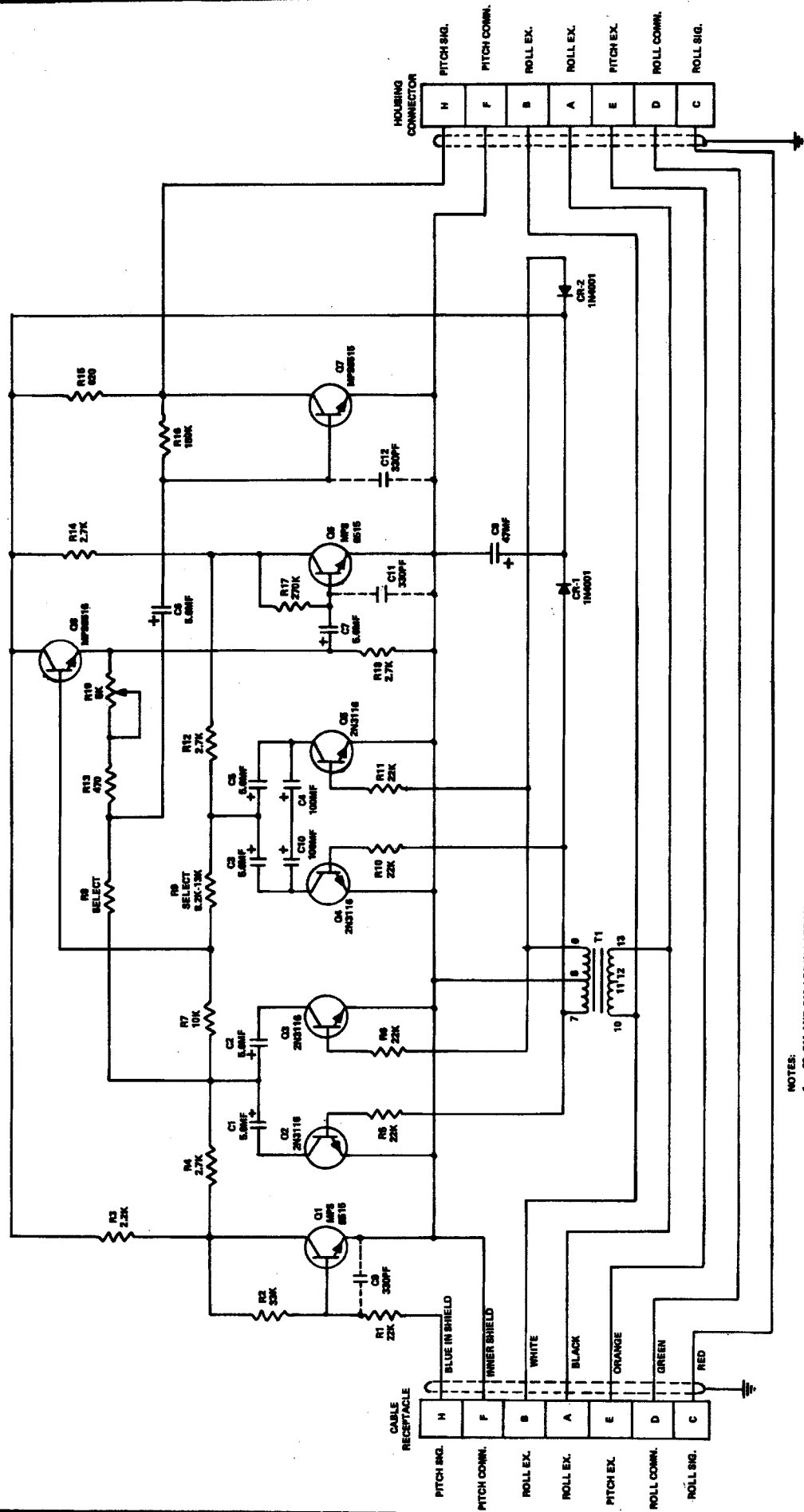

FIGURE 4-9B
 ROLL SIGNAL FILTER
 PRINTED CIRCUIT BOARD



- NOTES:
1. Q4, C11 AND C12 ARE IN LATE MODEL FILTERS ONLY.
 2. IN EARLY MODEL FILTERS Q4 AND C10 WILL BE A SINGLE 500P NON-POLARIZED CAPACITOR.

FIGURE 4-10A
PITCH SIGNAL FILTER
1B440-1 SCHEMATIC

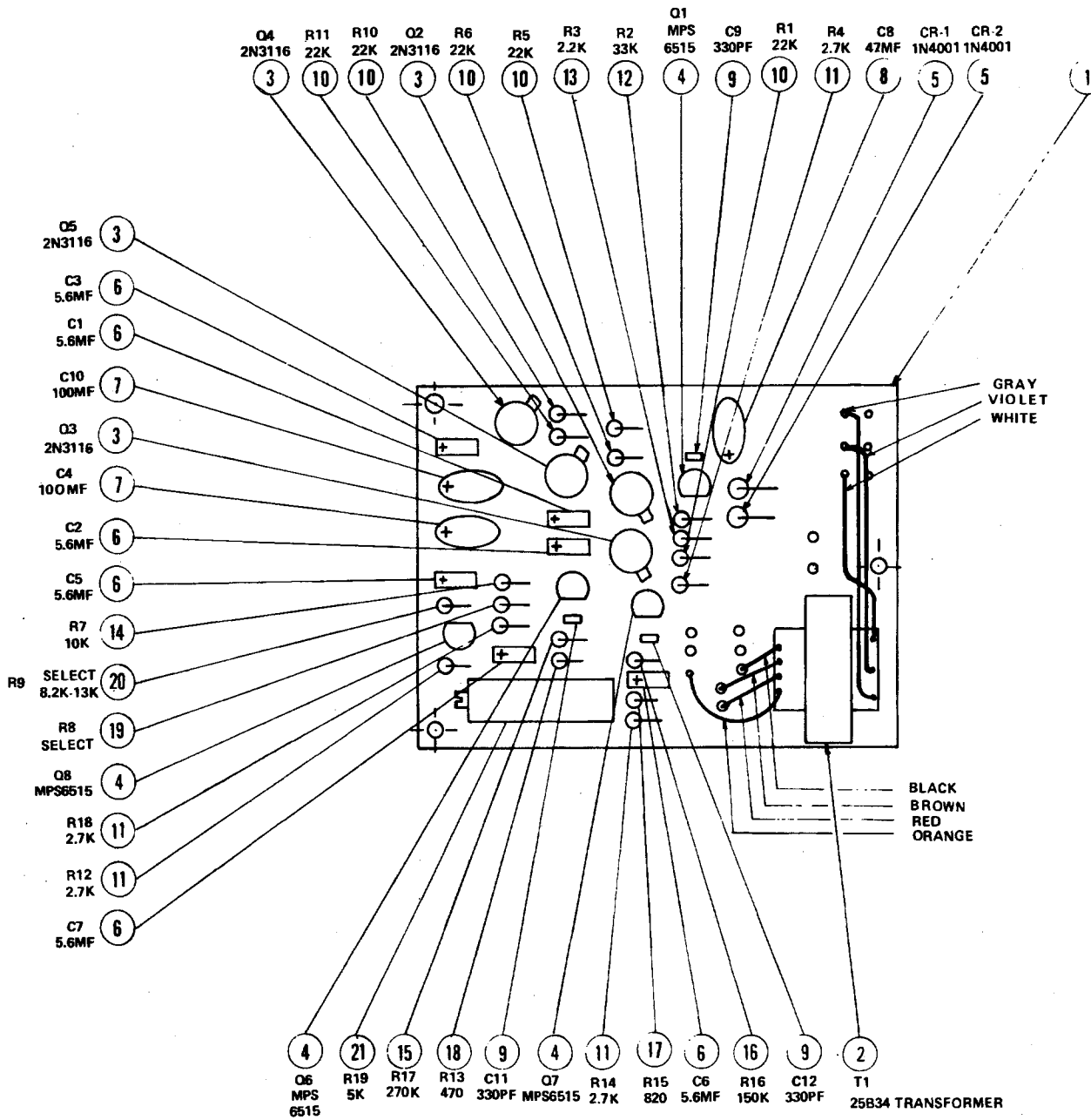

FIGURE 4-10B
PITCH SIGNAL FILTER
CIRCUIT BOARD

4.5 PITCH SIGNAL FILTER (1B440-1)

The Pitch Signal Filter operates in the same manner as the Roll Signal Filter. As in the Roll Signal Filter, units from serial number 309 and down, P-N-P transistors were used instead of N-P-N. Also, the supply voltage polarity is reversed.

The Pitch Signal Filter supply voltage is transformer coupled (T-1) from roll excitation for isolation. Diodes CR-1 and CR-2 rectify roll excitation. C-8 acts as a filter. The result is regulated D. C. to operate the amplifiers in the filter.

4.6 RADIO COUPLERS

There are three basic types of Radio Couplers, each of which has a modification that allows it to be used with ARINC HEADING SYSTEMS, designated by a "C" following the part number. The three basic types are identified by comparing the serial number with the following chart:

SERIAL NO.	SCHEMATICS		REMARKS
1C388 Serial No. to 1494D Piper No. to 1480D Serial No. ending in A, B, C, or D	1C388	1C388C	Has mic. key circuit. Components on the circuit board.
1C388 Serial No 1,480E or F to 6,000 G			Components on two circuit boards. Has R. F. I. protection eliminating need for mickey circuit
1C388M Serial No. 6,000G and Above			Uses Integrated Circuit in the Heading Circuits. Uses pots instead of select resistors
For Wiring Interconnect Diagram see Section V			

The following will outline the basic and detailed theory of Radio Couplers:

4.6.1 Theory - The Radio Coupler is installed in line with the Directional Gyro and receives excitation (Roll) from the amplifier. In the HDG mode the signal from the Directional Gyro passes through the coupler to the amplifier unchanged. In the Omni mode the Directional Gyro is set to correspond to the OBS to provide course information. A radio deviation signal from the NAV Converter is summed with the course signal. This composite signal is applied to the autopilot amplifier allowing it to intercept and track a radio course.

4.6.1 (a) 1C388 RADIO COUPLER - SERIAL NO. 6,000 AND ABOVE

In the following discussion, it will be necessary to refer to the Radio Coupler Schematic Figure 4-11. The D. G. signal from pin A of CD-33 (to DG) is applied through R-1 to a synchronous filter Q-1 and Q-2. The signal is also applied to one contact of S-1 where, in the HDG Mode, it is coupled to pin A of CD-33 (to the amplifier). From the emitters of Q-1 and Q-2 a proportional D. C. signal is applied to an operational amplifier 1C1.

The DG signal becomes very non-linear beyond 50° from center. To compensate for this, CR-3 and CR-4 (6.2V Zener) shunts some of the feed-back to common when the output reaches approximately 6.80 or about the point where the D. G. signal becomes non-linear. At this point, the gain of the operational amplifier is increased enough to cause a linear output from 1C1 for DG signals up to approximately 80° offset from center.

The output of the 1C1 is applied to the cross wind diodes CR-5 and CR-6 and a small portion through R-18 is applied to the summing network.

The cross wind diodes block small heading signals (less than 15°) allowing the coupler to establish a cross wind or crab to keep the deviation indicator centered. R-13 and R-14 are the left and right intercept adjustments, respectively. They are adjusted so that 45° of heading deviation cancels 100° of radio deviation. R-16 is used to vary the range of intercepts obtainable with R-13 and R-14. The DG signal through R-16 and R-17 is applied to a summing point and mixed with the radio deviation signal before being applied to the output chopper Q-3.

The OMNI deviation indicator supplies an ARINC signal (150mv maximum left or right) to CD-34 pins A and B. In the NAV mode C-30 and C-31 shunt the radio input to provide dampening. Also, SW-3 will open part of the rate circuitry C-26 and C-27.

In the Omni mode, C-30 and C-31 are by-passed with SW-6. SW-3 will switch reduced rate in with R-48 in series with C-26 and C-27.

In the LOC mode, SW-3 by-passes R-48 for the maximum rate signal. SW-5 will by-pass R-49 if the Coupler is used with an ARINC NAV indicator. R-49 is jumpered when used with non ARINC NAV indicators. Also, in the LOC mode, SW-4 will provide a ground to the Glide Slope Coupler.

In the LOC Rev. mode the radio input is reversed by SW-5 and SW-6.

The radio signal from SW-5 and SW-6 is applied to a shopper Q-4 and Q-5. From the junction of C-13 and C-14 a proportional square wave is applied to A. C. amplifiers Q-6 and Q-7. The gain of the amplifiers is controlled by R-36 (Radio Gain) varying the amount of feed-back from Q-7 to the emitter of Q-6. The amplified square wave is transformer coupled through T-1 to the phase detector.

NOTE: The chopper and amplifier section is completely transformer isolated above ground to protect the radio signal input.

The phase detector brings the square wave radio signal back to a varying D. C. R-41 is used to center the output of the phase detector with the radio signal centered. CR-11 and CR-12 (matched 6.2 V Zener diodes) will limit the output of the phase detector to 100% radio signal. R-36 (Radio Gain) is adjusted so the diodes limit the output of the phase detector just as the radio signal increases beyond 100%. Limiting occurs at approximately 6.8V between R-44 and CR-12.

The output of the phase detector is summed with the DG signal through R-45 and through R-46 and the rate circuitry.

The resulting signal at the summing point is chopped by Q-3 and applied to the autopilot amplifier as the DG signal.

4.6.1 (b) 1C388 RADIO COUPLER (SERIAL NO. 1,480 TO 6,000):

The DG signal from the directional gyro is applied to the Radio Coupler through pin A of CD-33 (to DG). See Fig. 4-12. In the heading mode, the signal is coupled through S-1 to pin A of CD-33 (to amp.). The signal is also applied to the heading phase detector through T-1. From the phase detector, a proportional DG signal is applied to the crosswind diodes. CR-3 and CR-4 will block small heading signals (less than 15°) allowing the coupler to establish a crab to keep the deviation indicator centered. R-6 and R-7 are the left and right intercept adjustments. They are adjusted so 45° of heading deviation will cancel 100% of radio deviation. The DG signal through R-8 is applied to the summing point and rate network between R-12 and C-6. A small heading signal that by-passes the crosswind network through R-14 is also applied to the summing point. This by-passed signal adds stability and prevents hunting under small crosswind conditions.

The omni deviation indicator supplies a D. C. signal (150mv maximum left or right) to CD-34 pins A and B. The radio signal is applied to a chopper, Q-1 and Q-2, on the 79B57 P. C. board. A proportional square wave through L-1 and L-2 (noise filter) is applied to the base of Q-4 on the 1C412 P. C. board. Q-4 and Q-5 amplify the radio signal and couples the signal to the phase detector through T-2. R-26 (Radio Gain) varies the amount of feed-back from Q-5 to Q-4.

NOTE: The chopper and amplifier section is completely isolated above ground to protect the radio signal input.

The phase detector brings the square wave radio signal back to a proportional D. C. signal. R-32 is selected to zero the output of the phase detector with a zero input. CR-8 and CR-9 (matched 6.2V Zener diodes) will limit the output of the phase detector to 100% (radio signal deflection). Radio Gain (R-26) is adjusted so the diodes limit the output of the phase detector just as the radio signal increases beyond 100% of full scale. Limiting occurs at approximately 6.8V between R-35 and CR-9.

The output of the phase detector is summed with the DG signal through R-17 and the rate circuitry.

The rate circuitry consists of C-7 and R-16, C-10 and R-17. The capacitors provide a low resistance path around the resistors for any changing radio signal as they charge or discharge.

The resulting signal between R-12 and C-6 is chopped by Q-2. This signal is substituted for the DG signal in the NAV, OMNI OR LOCALIZER modes through S-1.

In the NAV mode the rate circuitry is reduced by opening a rate path through C-10 and S-3. S-6 will also switch C-8 across the radio input for dampening in the NAV mode.

In the Omni mode, S-3 will provide a reduced rate signal by switching R-36 in series with C-10. Also in the Omni and Nav modes, R-37 is added to the radio signal input by S-5 in couplers used with ARINC indicator only. R-37 should be jumpered when used with non-ARINC radio signals.

In the LOC NORM mode, S-3 removes R-36 to increase the rate through C-10. S-5 will by-pass R-37 if the coupler is used with an ARINC indicator. The jumper around R-37 is clipped when

In the LOC NORM mode, S-3 removes R-36 to increase the rate through C-10. S-5 will by-pass R-37 if the coupler is used with an ARINC indicator. The jumper around R-37 is clipped when the coupler is used with an ARINC converter. Also, S-4 will provide a ground to the G/S coupler. In the LOC REV mode, S-5 and S-6 reverse the radio input signals.

In the LOC or LOC REV modes, S-2 adds R-15 from the summing point to roll common, shunting a part of the signal at the summing point. R-15 effectively limits the bank angles in the modes to prevent excessive overshoot or S-turning down the localizer.

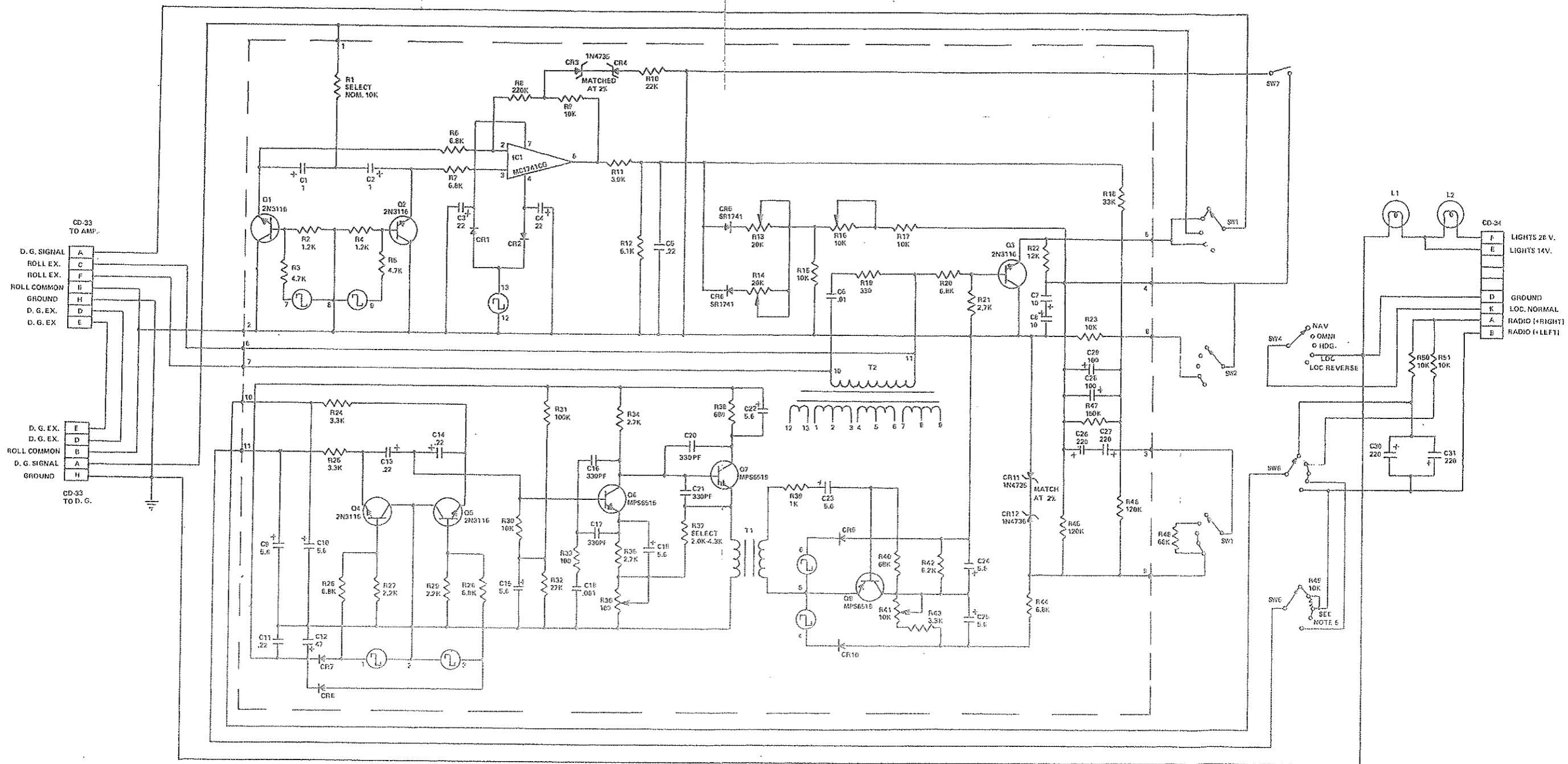

- NOTES:
1. ALL CAPACITORS ARE IN M. F. D. EXCEPT AS NOTED.
 2. ALL RESISTORS ARE IN OHMS EXCEPT AS NOTED.
 3. ALL RESISTORS ARE 1/4 WATT EXCEPT AS NOTED.
 4. ALL DIODES ARE 1N4001 EXCEPT AS NOTED.
 5. JUMPER ACROSS R45 TO BE REMOVED WHEN USED WITH OMNI CONVERTER
10° - 150 MILLIVOLTS.

FIGURE 4-11A
1C388 RADIO COUPLER
SERIAL NUMBERS 6,000 AND ABOVE

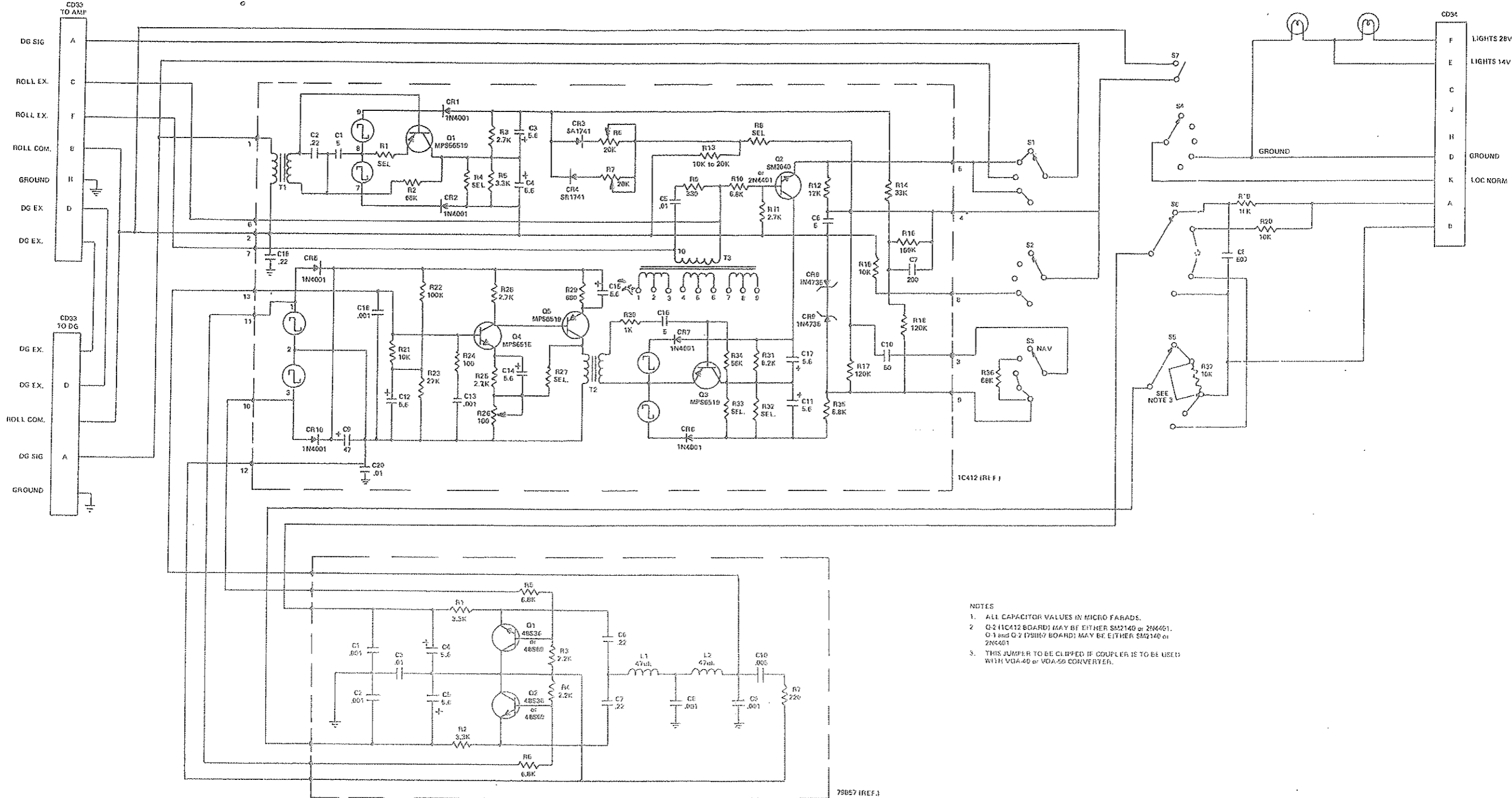

- NOTES
1. ALL CAPACITOR VALUES IN MICRO FARADS.
 2. Q2 (1C412 BOARD) MAY BE EITHER SM2140 or 2N4461.
Q3 and Q4 (79B57 BOARD) MAY BE EITHER SM2140 or 2N4401
 3. THIS JUMPER TO BE CLIPPED IF COUPLER IS TO BE USED WITH VOA-40 or VOA-50 CONVERTER.

FIGURE 4-12A
1C388 RADIO COUPLER
SERIAL NUMBERS 1,480 to 6,000

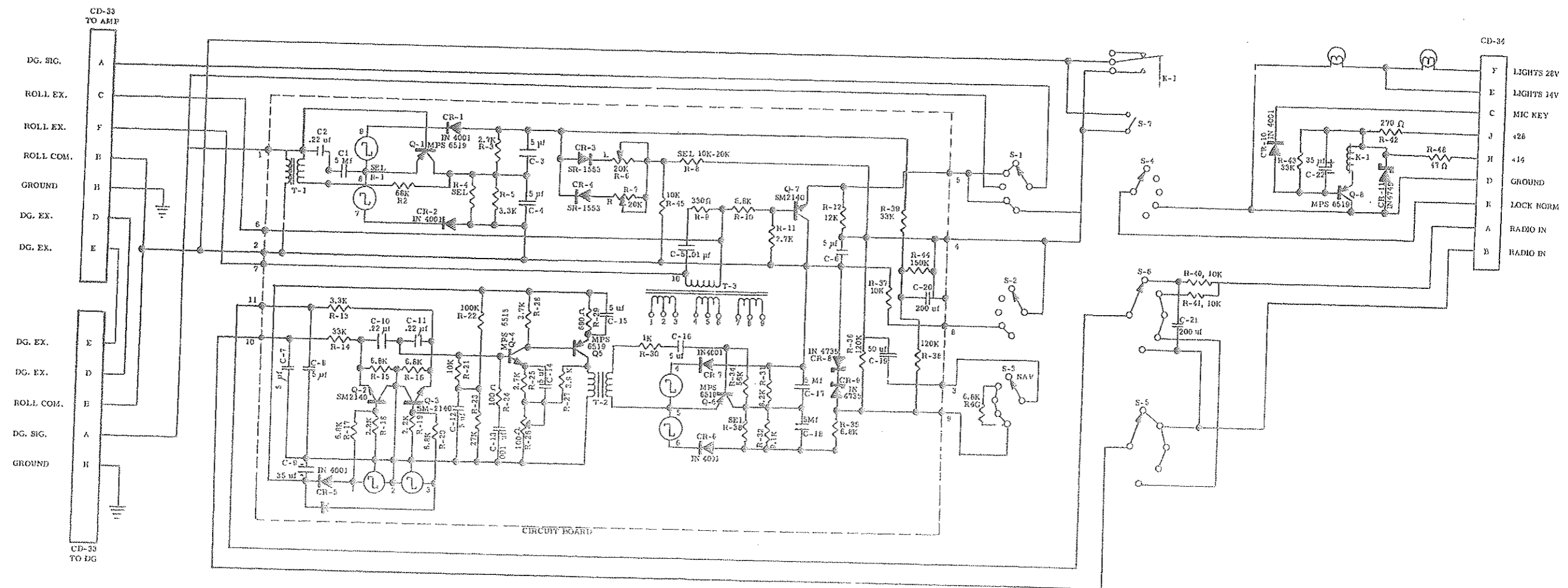
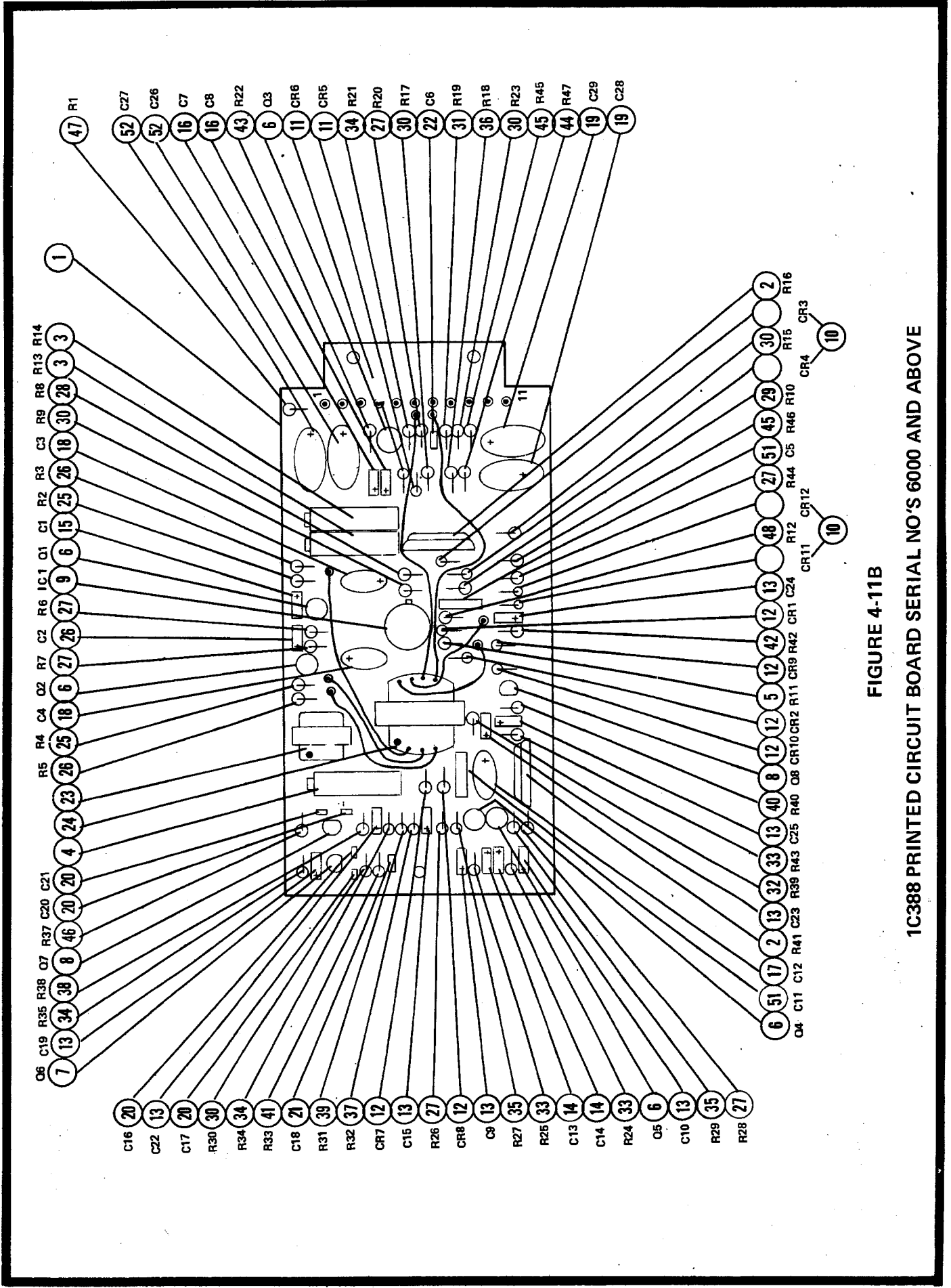

FIGURE 4-13A
1C388 RADIO COUPLER SCHEMATIC SERIAL NO'S UP TO 1480



- 1
- 2
- 3
- 4
- 5
- 6
- 7
- 8
- 9
- 10
- 11
- 12
- 13
- 14
- 15
- 16
- 17
- 18
- 19
- 20
- 21
- 22
- 23
- 24
- 25
- 26
- 27
- 28
- 29
- 30
- 31
- 32
- 33
- 34
- 35
- 36
- 37
- 38
- 39
- 40
- 41
- 42
- 43
- 44
- 45
- 46
- 47
- 48
- 49
- 50
- 51
- 52

FIGURE 4-11B

1C388 PRINTED CIRCUIT BOARD SERIAL NO'S 6000 AND ABOVE

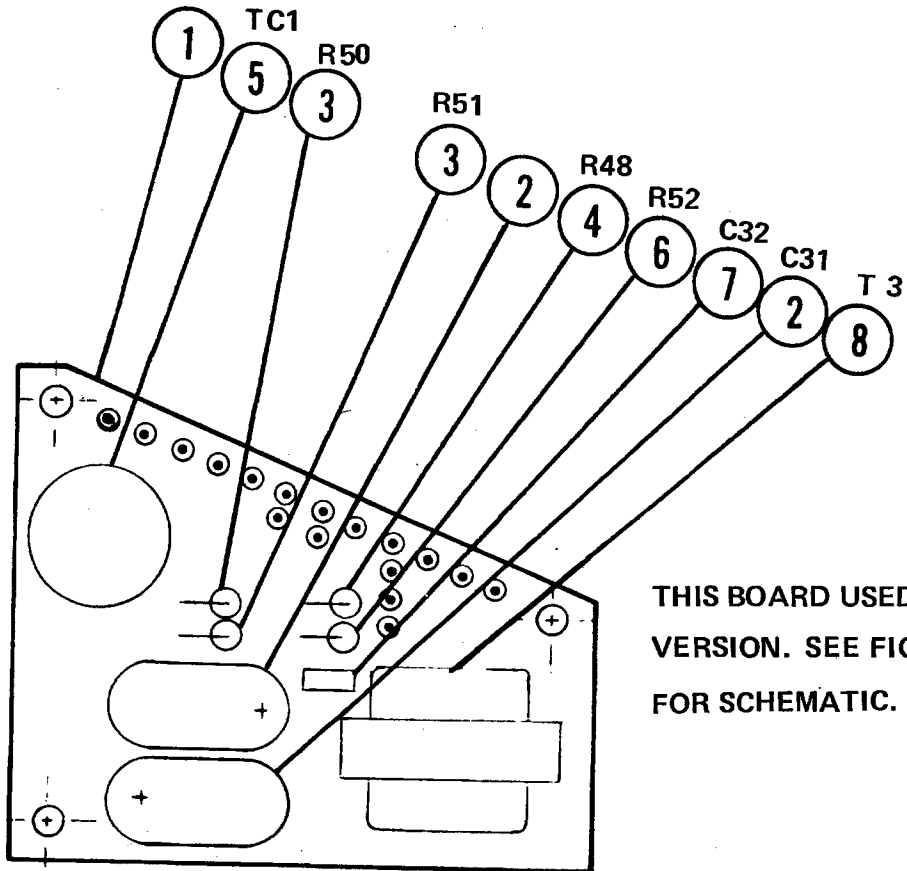
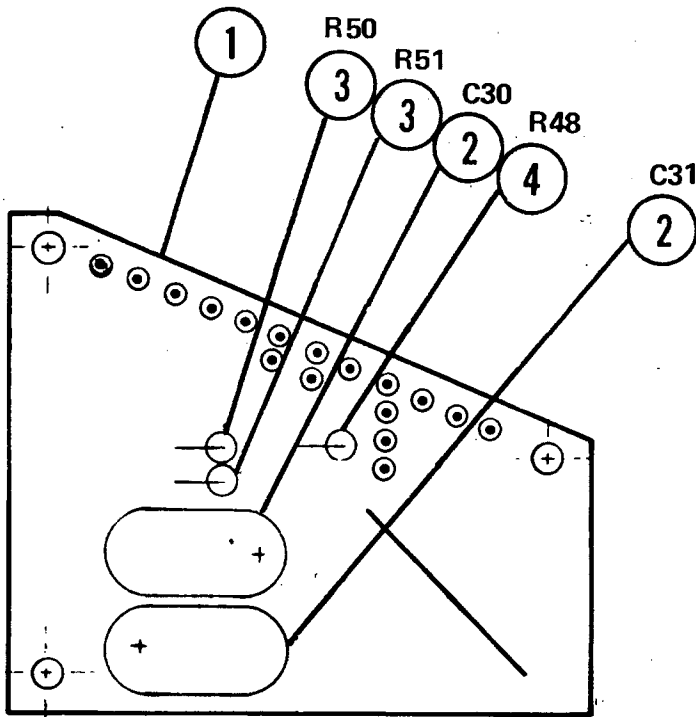

THIS BOARD USED IN 1C388C
VERSION. SEE FIGURE 4-14
FOR SCHEMATIC.

FIGURE 4-11B (CONTD)

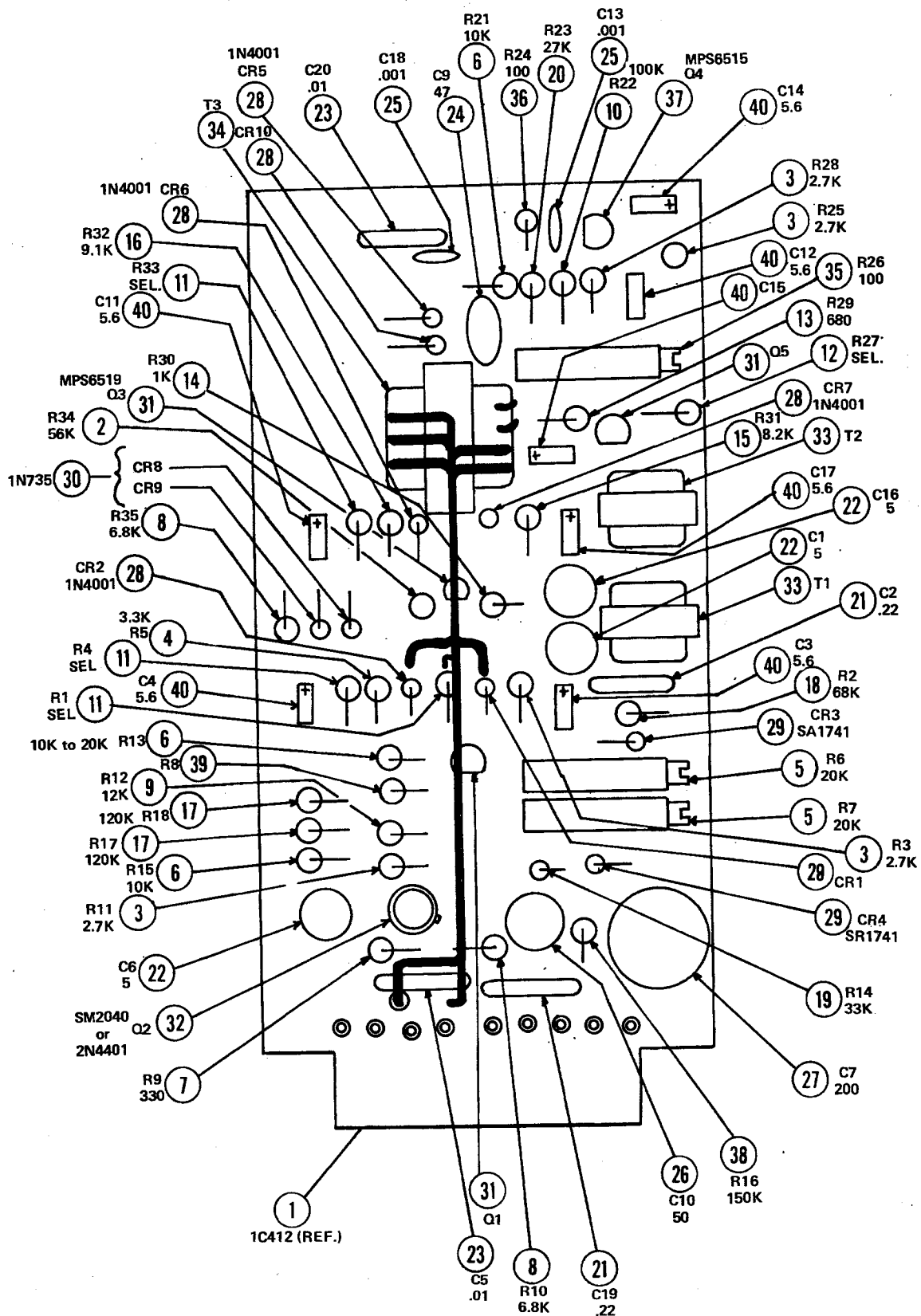
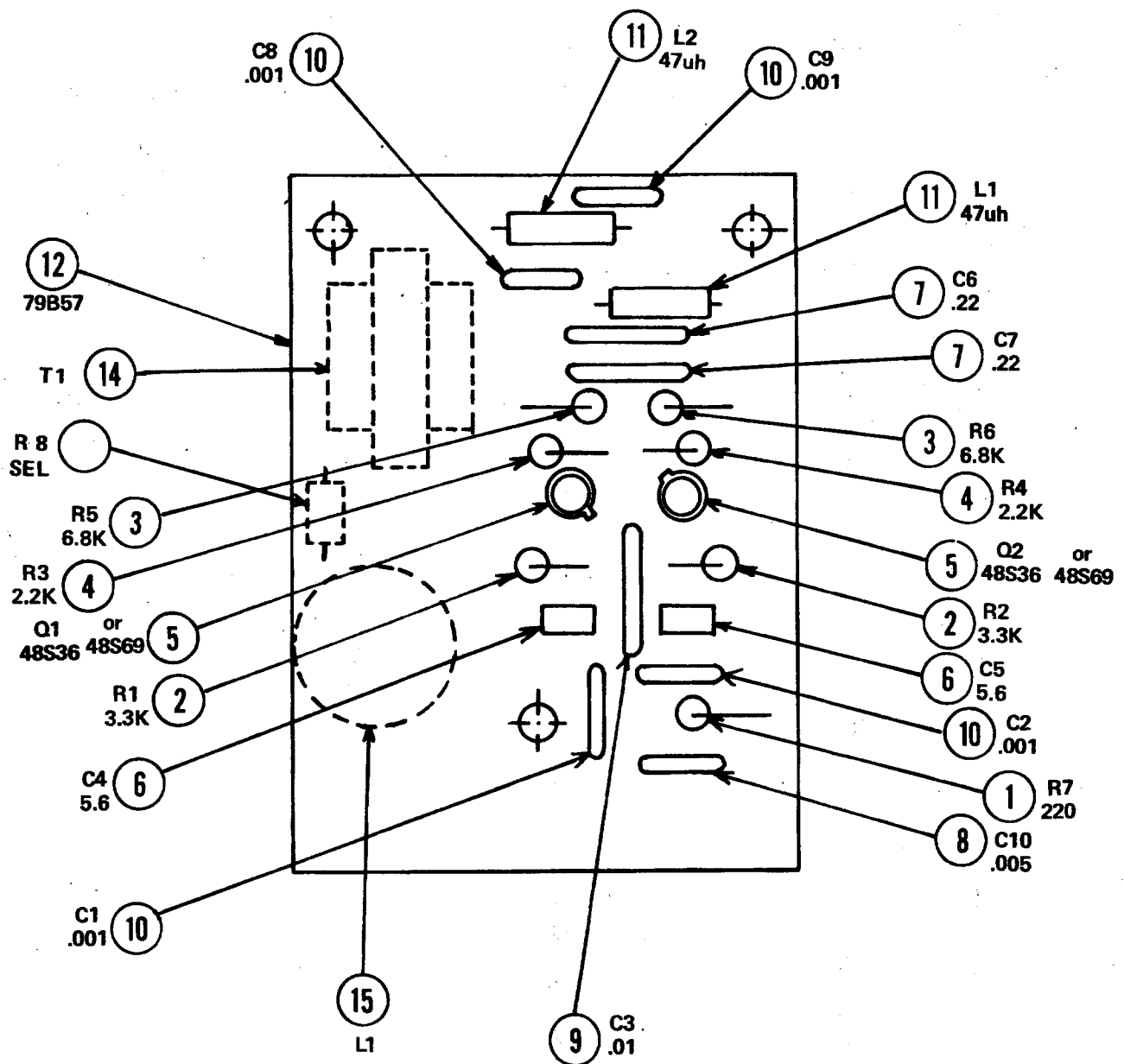

FIGURE 4-12B

1C388 PRINTED CIRCUIT BOARD SERIAL NO'S 1480 TO 6000



NOTE: L1, R8, AND T-1 ARE USED IN 1C388C COUPLERS ONLY (ARINC).

FIGURE 4-12B (CONTD)

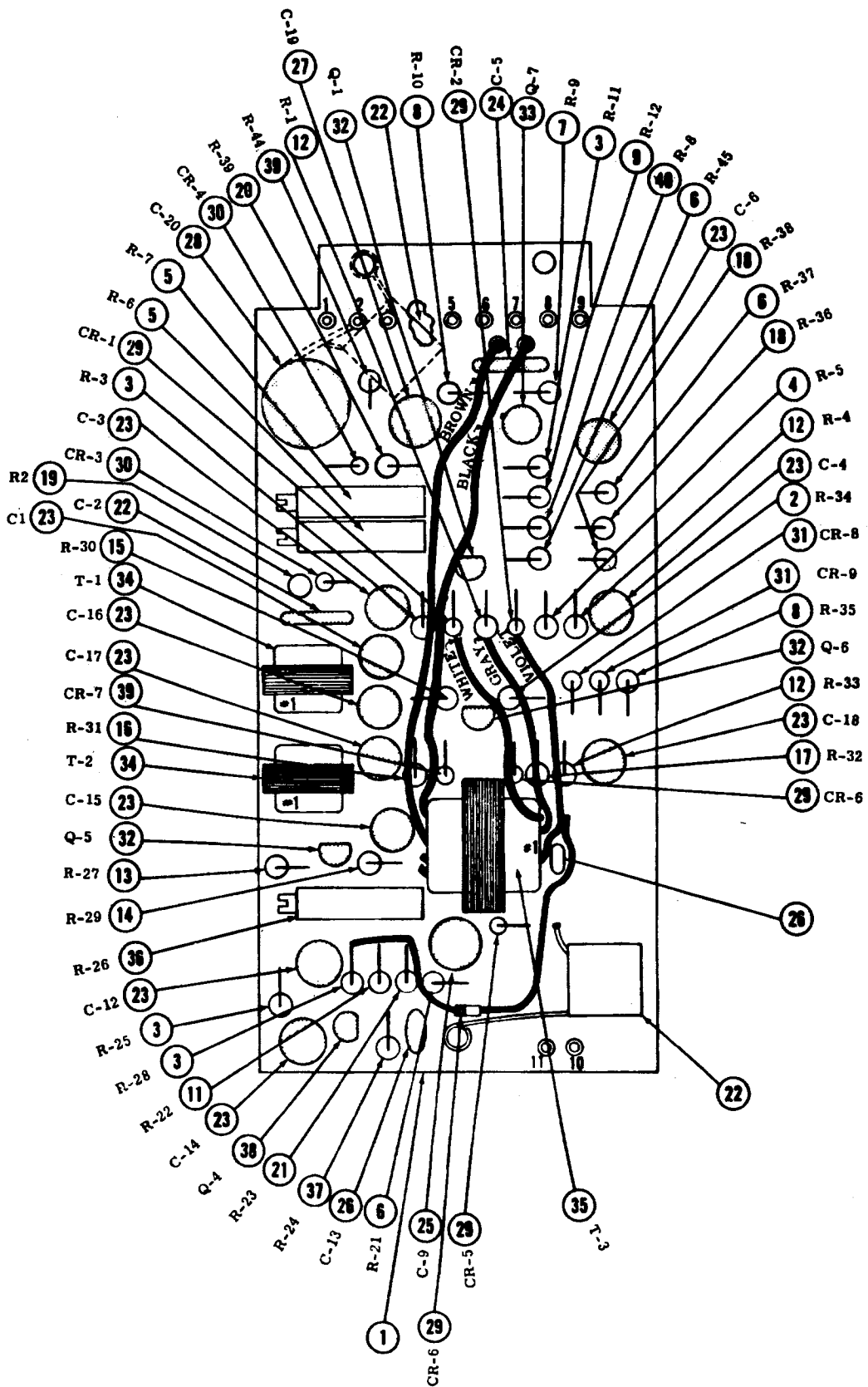

1C388 PRINTED CIRCUIT BOARD SERIAL NO'S TO 1480

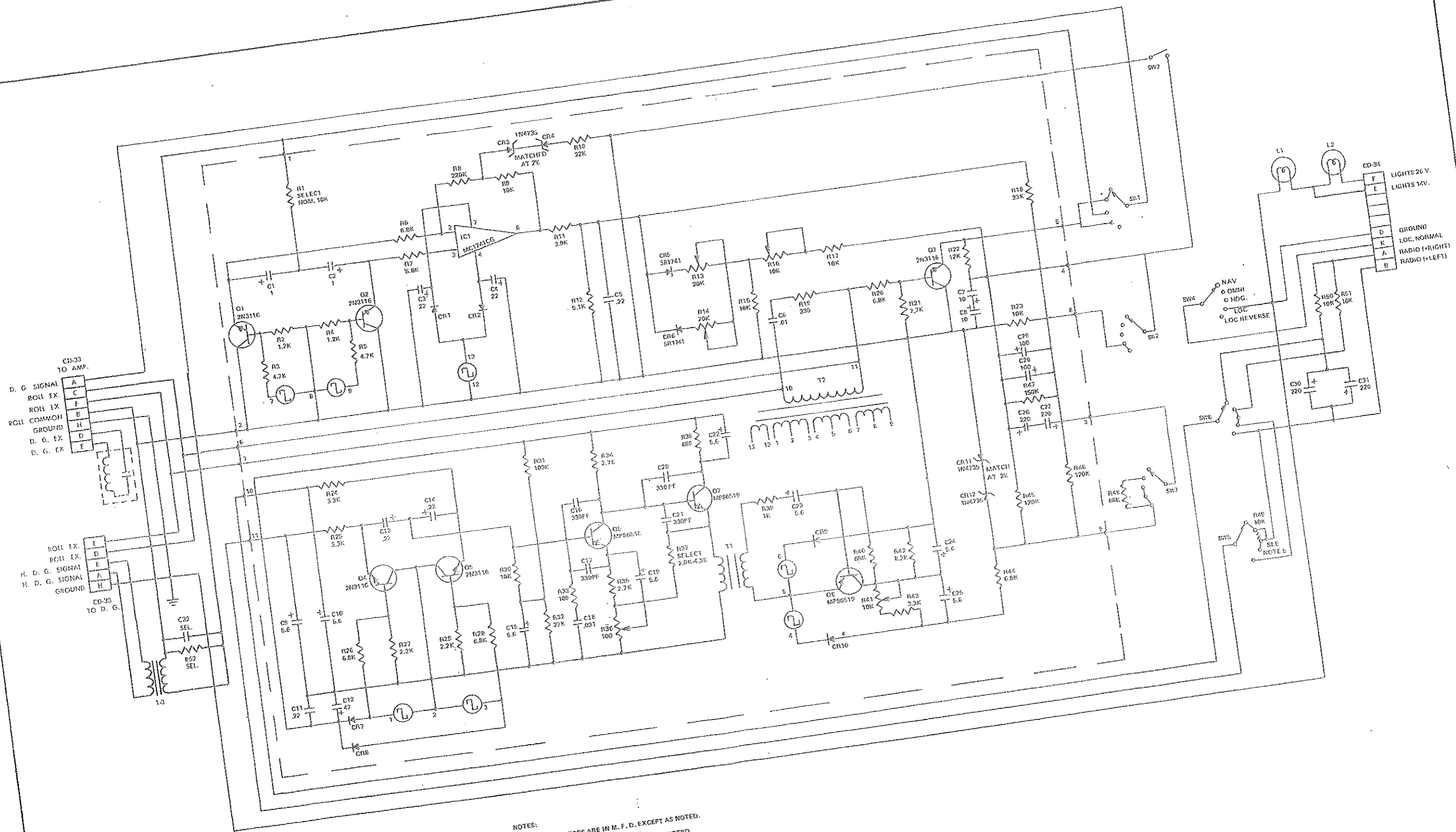

- NOTES:
1. ALL CAPACITORS ARE IN M. F. D. EXCEPT AS NOTED.
 2. ALL RESISTORS ARE IN OHMS EXCEPT AS NOTED.
 3. ALL RESISTORS ARE 1/4 WATT EXCEPT AS NOTED.
 4. ALL DIODES ARE 1N4001 EXCEPT AS NOTED.
 5. JUMPER ACROSS R49 TO BE REMOVED WHEN USED WITH OMNI CONVERTER 100 - 150 MILLIVOLTS.

FIGURE 4-14
1C388C RADIO COUPLER ARINC SCHEMATIC
SERIAL NUMBERS 6,000 AND ABOVE

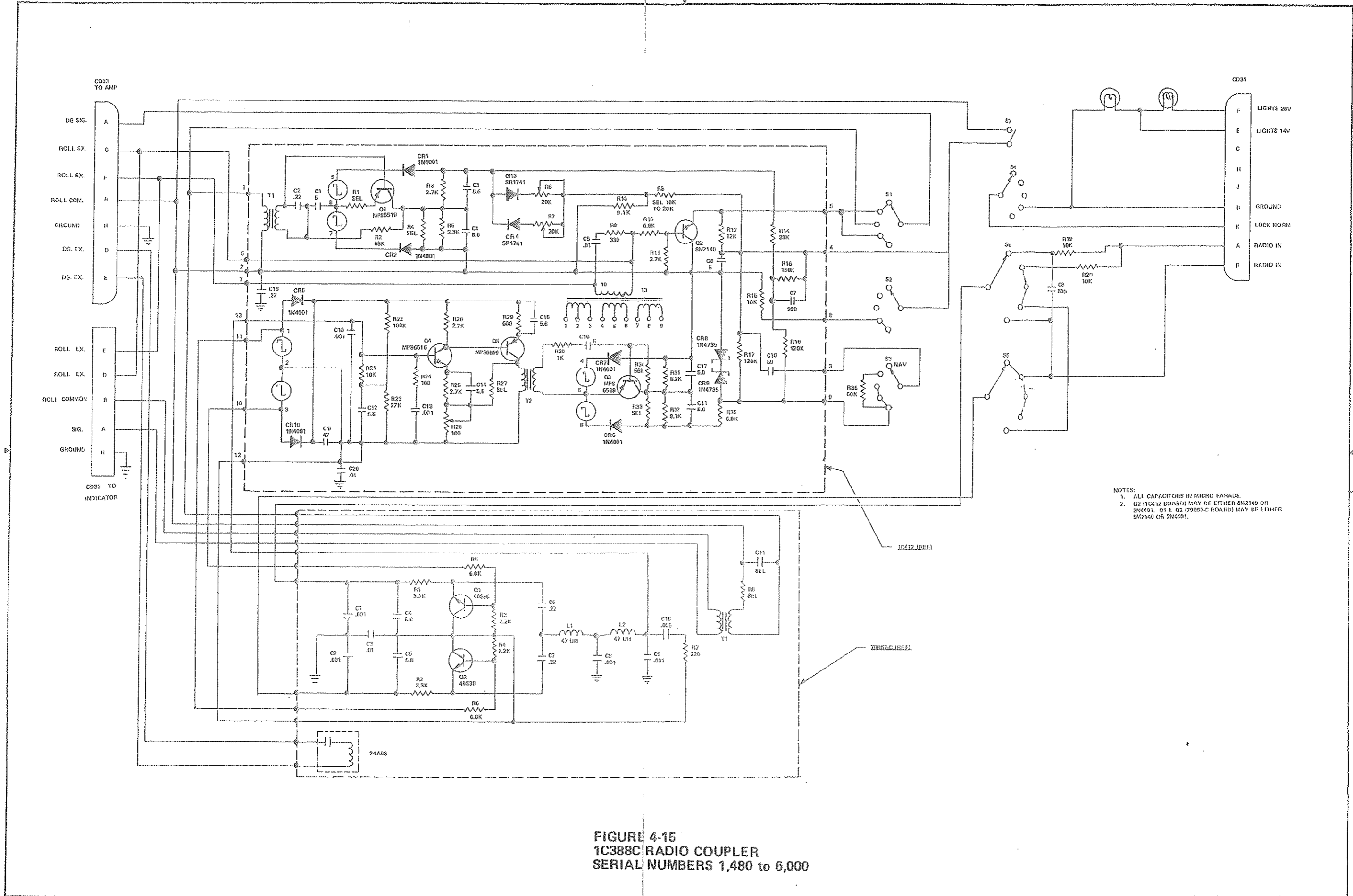

- NOTES:
1. ALL CAPACITORS IN MICRO FARADS.
 2. Q2 (1C412 BOARD) MAY BE EITHER 2N2140 OR 2N6401. Q1 & Q2 (70B57-C BOARD) MAY BE EITHER 2N2140 OR 2N6601.

FIGURE 4-15
1C388C RADIO COUPLER
SERIAL NUMBERS 1,480 to 6,000

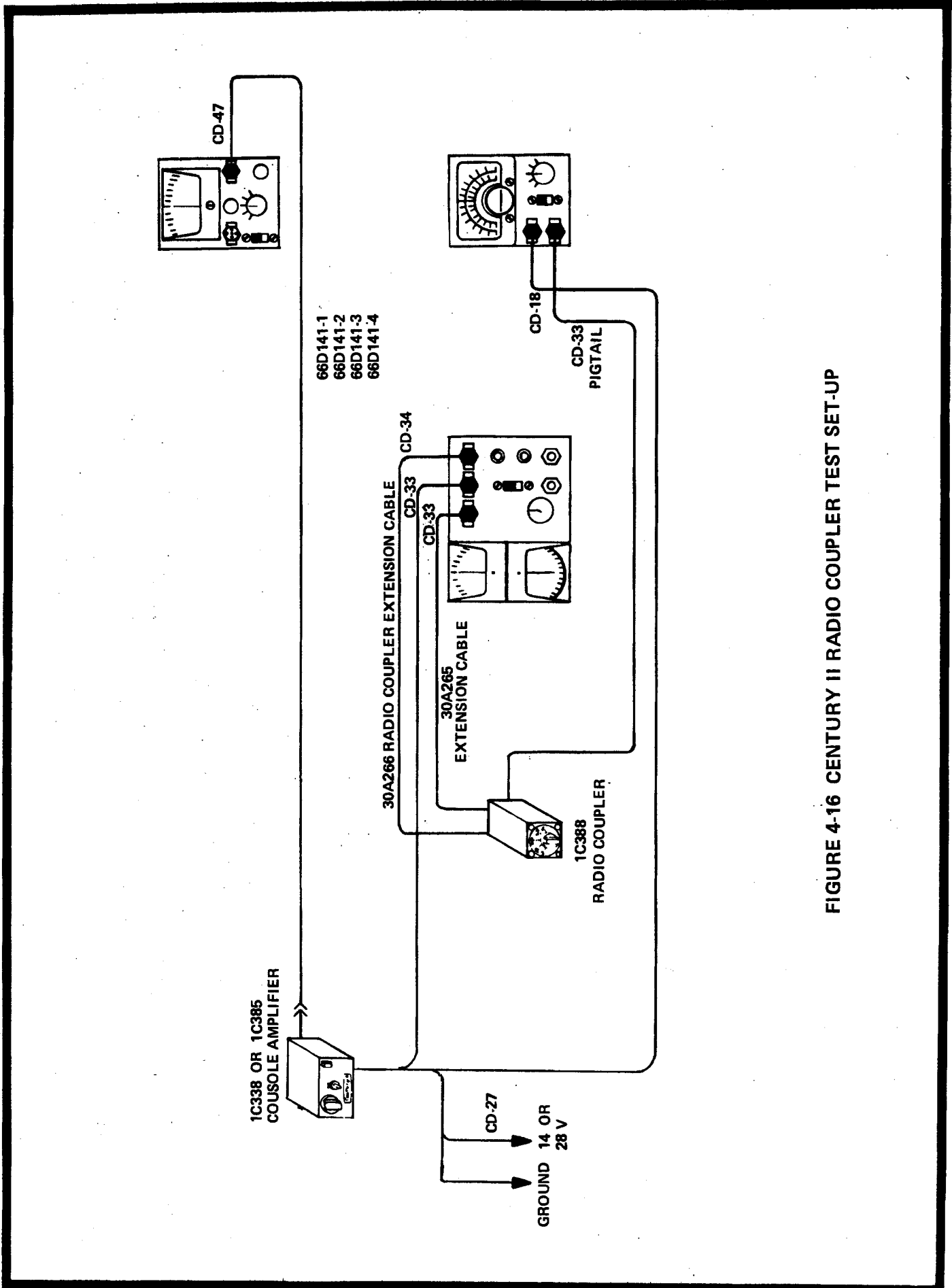
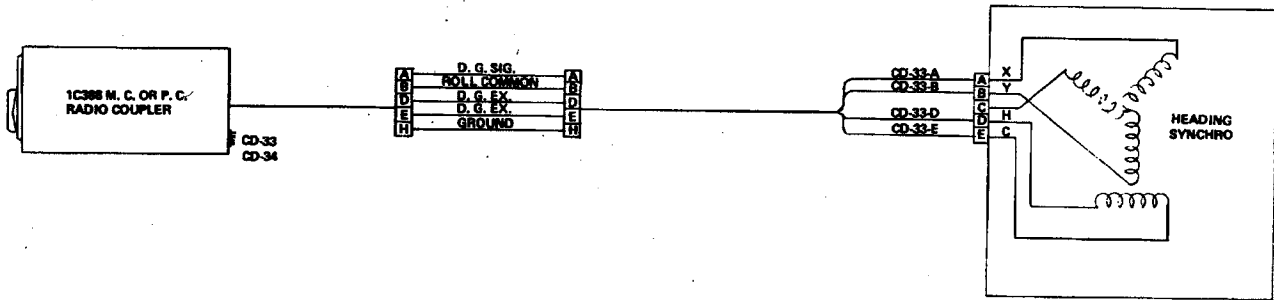

FIGURE 4-16 CENTURY II RADIO COUPLER TEST SET-UP



**1C388 M. C. OR P. C. RADIO COUPLER
TEST BOX**

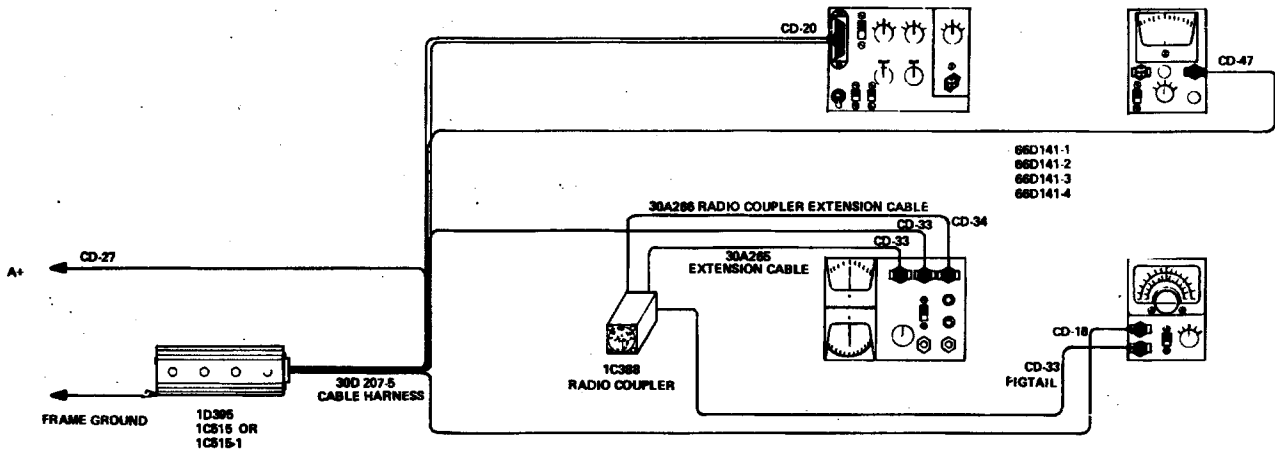

FIGURE 4-17 CENTURY III RADIO COUPLER TEST SET-UP

4.6.1(d) 1C388C AND 1C388MC RADIO COUPLERS:

The 1C388 and 1C388M radio couplers are used with the Edo Avionics directional gyro (52D54). Radio couplers used with ARINC heading systems (1C388C or 1C388MC, Figures 4-16 and 4-17) have an additional tuned circuit to substitute for the tuned circuit found in the 52D54 DG. These couplers will use roll excitation to excite the heading synchro in the heading system used. The heading signal from the heading synchro is transformer coupler to the DG circuit in the radio coupler (T-1, 79B57 P. C. board in 1C388 and T-3 in the 1C388MC) and used as the DG signal.

Radio Coupler 1C-388 Tests (Serial No. 6,000 AND ABOVE)

4.6.2 A. Test Equipment Required:

1. Oscilloscope H. P. - 120 or equivalent
2. 66D141 Test Set
3. 52D54 Directional Gyro

B. Test Set-Up:

1. Set up test equipment per Fig. 4-15 or 4-16, use 52D54 Directional Gyro instead of gyro substitute.
2. Set oscilloscope as follows:
 - (a) 50u sec/cm
 - (b) vertical input - D. C.
3. Check voltage switches in correct position
4. Turn system on in HDG mode
5. Set Radio Coupler to Omni mode

C. Radio Centering and Gain:

1. Connect oscilloscope to radio phase detector output (junction of R-44 and CR-12). See Figures 4-11 through 4-15.
2. With no input from the Coupler Tester (66D141-4) zero the output of the phase detector with R-41.
3. Set the Radio Signal Substitute to 100% right. Check the radio gain (R-16) is adjusted so the output of the phase detector is limited at this point. The output should not increase with more than 100% radio but will begin to decrease as the radio signal is decreased below 100%.
4. Set the Radio Signal Substitute to 100% left. The phase detector output will limit within 10% of the right.
5. Set the oscilloscope to monitor the output of Q-3. Set DG to zero.
6. No more than 5% radio signal should be required to zero the output.

D. Intercept Angles:

1. Set left and right intercept pots full CCW.
2. Set Radio Signal Substitute to 100% right.
3. Null the output on the Coupler Tester with the DG. It should take a maximum of 40° DG offset.
4. Set Radio Signal to 100% left.
5. It should take a maximum of 40° DG to null output.
6. Set intercept pots to full CW.
7. It now should take over 50° to null 100% radio input.
8. If necessary R-16 may be adjusted to vary the range of maximum and minimum intercepts.

9. Set left and right intercept pots for 45° intercepts with 100% radio input.
10. Set Radio Signal to 60% left. It should take $38^{\circ} \pm 2$ DG offset to null output.
11. Set Radio Signal to 60% right. $38^{\circ} \pm 2$ for null.

E. Crosswind Checks:

1. Set Radio Coupler to NAV mode.
2. Heading deviations of 15° in either direction should not require more than 10% radio input to null output.
3. Set DG to 0. Turn Radio Signal Substitute off.
4. Allow time for the output to stabilize, then set DG to 10° left or right. The time required for the output to reach a maximum and then decay to 0.4 of the maximum level should be 8 to 16 seconds.

F. Radio Rate:

1. Set Radio Coupler to LOC mode, Set DG to 0.
2. Set Radio Signal Substitute to 100% and allow output to stabilize.
3. Turn Radio Signal off. The time required for the coupler output to rise in the opposite direction and then decay to a value equal and opposite to the initial value (step 2) should be a minimum of 2 seconds and a maximum of 8 seconds.

4.6.3 RADIO COUPLER 1C388 TESTS: (SERIAL NO. BELOW 6,000)

A. Test equipment required:

1. Oscilloscope
2. 66D141 test set
3. Century II or III amplifier
4. 52D54 D. G.

B. Test set up:

1. Set test equipment per Fig. 4-16 or 4-17
2. Set oscilloscope as follows:
 - (a). .50u/sec/cm
 - (b). Vertical input DC
3. Check voltage switches in correct position
4. Turn system on in Heading Mode
5. Set radio coupler to Omni Mode

C. Radio Centering and Gain.

1. Connect oscilloscope to radio phase detector output (junction of R-35 and CR-9) and roll common.
2. With the Radio Signal Substitute (66D141-4) zero the output of the phase detector. The coupler tester should show $0 \pm 4\%$.
NOTE: Allow time for the output to stabilize.
3. Set the Radio Signal Substitute to 100% right. Check the Radio Gain is adjusted so the output of the phase detector is limited at this point. The output should not increase with more than 100% radio, but will begin to decrease as the radio signal is decreased below 100%.
4. Set the Radio Signal Substitute to 100% left. The phase detector output will limit within 10% of the right.
5. Set the oscilloscope to monitor the output of Q-3. Set D. G. to zero.
6. No more than 5% Radio Signal Substitute should be required to zero the output.

D. Intercept Angles:

NOTE: Allow time for output to stabilize after each adjustment.

1. Set left and right intercept pots full CCW.
2. Set Radio Signal Substitute to 100% right.
3. Null output on the Coupler Tester with the D. G. It should take 40° or less offset to null output.
4. Set Radio Signal Substitute to 100% left.
5. It should take 40° or less to null output.
6. Set intercept pots to full CW.
7. It now should take over 50° to null 100% left and right radio input.
8. Set left and right intercepts for 45° with 100% radio input.
9. Set Radio Signal to 60% left. It should take 38° or less D. G. offset to null output.
10. Set Radio Signal to 60% right. 38° or less for null.

E. Crosswind Checks:

1. Set Radio Coupler to NAV mode.
2. Heading deviations of 15° in either direction shall not require more than 10% radio input to null output.
3. Set DG to 0. Turn Radio Signal SUBstitute off.
4. Allow output to stabilize, then set DG to 10° left or right. The time required for the output to reach a maximum level and then decay to 0.4 of the maximum level shall be 8 to 16 seconds.

F. Radio Rate:

1. Set Radio Coupler to LOC mode. Set DG to 0.
2. Set Radio Signal to 100% and allow the output to stabilize.
3. Turn Radio Signal Substitute off. The time required for the coupler to rise in the opposite direction and decay to a value equal and opposite to the initial value (step 2) should be between 2 and 8 seconds.

1C388 AND 1C388C (Serial No. 1450 to 6,000)

Resistor	Value	Reference
R-1	43-69 OHMS 1/2W	4.6.2 D
R-4	4.7K - 20K 1/2W	4.6.2 D See Note 1
R-8	10K - 20K	4.6.2 D
R-27	1K - 4.7K	4.6.2 C Step 4 (see note)
R-33	27K - infinity	

NOTE 1: R-4 is selected to zero the output of the phase detector with D. G. centered.

NOTE 2: R-27 selects the range of the Radio Gain adjustment R-26.

Under certain conditions, select resistors may have to be changed to bring the performance of a radio coupler within specifications. Select resistors are used to set the centering or gain for a particular stage. For example, R-1 selects the gain of the heading phase detector while R-4 is used to zero the output with the heading input zeroed.

Select resistors should be used only when no other problem can be found in the circuits such as a transistor that changed characteristics or a bad capacitor.

4.7 GLIDE SLOPE COUPLER (OPTIONAL)

4.7.1 Theory - The glide slope coupler is an automatic analog computer that directs the autopilot to intercept and track the approach glide path. This unit together with the Radio Coupler, provides a complete and automatic ILS intercept capability for the Century III autopilot.

The Glide Slope arm and engage logic circuitry operate automatically as the glide slope is intercepted. Three inputs to the logic circuitry prevent coupling or engaging until the glide slope has been intercepted.

First, a ground is provided to the glide slope coupler (Pin 4, Fig. 4-19) only when the Radio Coupler is in the LOC-Norm position. This around path is interrupted during any other mode.

Second, the autopilot must be in the Alt. mode. Alt. engage solenoid voltage from the console is applied to a switching transistor Q14 in the G/S coupler. Q14 will be turned on and the collector voltage near zero volts allowing Q17 and Q19 to be switched off at the appropriate time. When the autopilot is in the Pitch mode, Q-14 is turned off and the collector voltage will to to approximately 7 volts. This voltage is applied to the bases of Q17 and Q19 keeping them turned on and keeping the coupler from arming or engaging.

Third, the glide slope deviation indicator must be deflected at least 60% up for 20 seconds before the glide slope coupler will arm. A negative voltage from the phase detector (below the glide slope) will allow C-20 to charge through CR-10. C-20 will charge enough in approximately 20 seconds to turn Q-15 off momentarily. A positive signal from the collector of Q-15 will be coupled through CR-11 and CR-12 to the base of Q-16, turning it on and Q-17 off.

The glide slope coupler is armed as Q-16 is switched on. The coupler engages when the negative signal from the phase detector across R-63 and R-64 decreases enough to allow the wiper arm of R-64 to become positive enough to turn Q-18 on and Q-19 off. The voltage on the collector of Q-19 will turn Q-20 on. Q-20 energizes K-1 and the glide slope coupler engages.

Several things happen when K-1 closes. The Alt. Hold solenoid voltage (Pin 22) is interrupted and used to illuminate the glide slope engaged lamp on the instrument panel. Also the Alt. signal from the alt. hold is opened (Pin 19, alt. signal in). Prior to engagement the pitch horizon signal from pin 1 to pin 9 of K-1 is sent directly to the autopilot amplifier. Upon engagement pins 1 and 9 open and horizon signal passes from pin 1 through the secondary of T-2 to pin 9 and back to the amplifier. From pin 6 to pin 9 an off-set signal from R-1 is added to the horizon signal to re-reference pitch centering down to the approximate angle of the glide slope.

A standard glide slope signal, varying 150 mv, floating D.C. signals, is applied to pins 6 and 7 of the coupler (Fig. 4-19). From this point, the signal is applied to a chopper (Q-1 and Q-2), A.C. amplifier (Q-3 and Q-4) and transformer coupled (isolation) to a phase detector stage. Also from the collector of Q-4 degenerative feed-back is applied back to the emitter of Q-3 through R-19, C-8 and R-17. R-17 varies the amount of feed-back to Q-3 which controls the output of Q-4 to the phase detector.

The phase detector (Q-5, CR-3, CR-4) brings the square wave signal back to a proportional D.C. signal referenced to ground at the junction of CR-4 and C-12. The output between CR-3 and C-11 is applied to the integrator, the output chopper, and to the arm and engage logic circuitry.

First, assume the glide slope has been intercepted and coupled. K-1 will be energized. The output of the phase detector is applied across R-36 to one side of the output chopper Q-11 and Q-12. Any changing signal at this point will be coupled through the rate circuit C-14 and R-37.

Also from the phase detector the signal is applied across R-26 to the inverting input of an operational amplifier (Q-8). The non-inverting input (Q-9) is held at ground potential through R-34.

The integrating element C-13 is connected from the output to the inverting input. Shorting C-13 will keep the output zero for any input (until K-1 energizes one set of contacts short C-13. When the coupler engages K-1 is energized allowing the integrator to operate.

The integrator produces an output only when there is a long term output from the phase detector or when the aircraft stays above or below the glide slope. This might happen with various wind conditions. The output of the integrator is applied to the emitter of Q-12 aiding the phase detector input to Q-11.

Q-11 and Q-12 chop the input back into a proportional square wave. The output between C-15 and C-16 is applied to the output amplifier Q-13. Q-13 drives the primary of T-2 adding a glide slope command signal to the Horizon signal through the secondary.

4.7.2 Glide Slope Coupler Tests

A. Test Equipment Required:

1. 66D141 Test Kit
2. Oscilloscope (H-P 120B or equivalent)
3. Century III amplifier
4. Glide Slope 66A216

B. Test Set-Up:

1. Connect the glide slope coupler as shown in Fig. 4-18.

C. Bench Testing:

1. Turn system power on. Assure proper input (14VDC or 28VDC).
2. Switch 66D141-3 Console Substitute to "ON" position.
3. Center "Altitude Control" knob on 66D141-3 Console Substitute.
4. Turn "Selector" knob on 66D141-2 Power Section to "RES" position.
5. Select "PITCH" position on 66D141-1 Gyro Substitute and center "Attitude Gyro" knob.
6. Center voltage output meter on 66D141-2 with "Pitch Trim" knob.
7. Pull out "Radio Signal Substitute" knob on 66D141-2 Coupler Tester, and rotate counter-clockwise to obtain 60% in blue arc.

NOTE: With reference to the 66D141-4 and 66D94 Coupler Tester, "BLUE" is up and "YELLOW" is down.

8. To arm the glide slope coupler maintain at least 60% on "Blue" scale for minimum of 30 seconds.
9. Reduce radio signal slowly by turning knob clockwise until "lock on" occurs. This can be determined by the green indicator light coming on and also a momentary output on the 66D141-2 Power Section Meter.

NOTE: Lock-on should occur when needle centers $\pm 10\%$. Adjust R-64 if necessary.

10. Push Radio Signal Substitute knob in to lock needle to "0" (centered).
11. Depress red button on 1C493 glide slope coupler and rotate adjustment pot next to red button full clockwise and center voltage meter on 66D141-2 Power Section by rotating Attitude Gyro knob on 66D141-1 Gyro Substitute to the "pitch up" position.

NOTE: Allow sufficient time for needle to stabilize on 0.

12. Record degrees required to zero needle.

13. With button still depressed rotate pot on back of 1C493 glide slope coupler full counter-clockwise and center voltage meter on 66D141-2 Power Section by rotating Attitude Gyro knob on 66D141-1 Gyro Substitute to pitch "down" position.
14. Record degrees required to zero needle. Total spread between up and down readings should be $6^{\circ} \pm 2^{\circ}$.
15. Center Attitude Gyro Knob.
16. Pull Radio Signal Substitute knob "out" (ON) on the 66D141-4 Coupler Tester.
17. Adjust 1C493 glide slope coupler "pot" to zero output on 66D141-2 Power Section Voltage Meter.
18. Allow about 1 1/2 minutes to stabilize after final adjustment.
19. Depress red button on 1C493 glide slope coupler and rotate Radio Signal Substitute on 66D141-4 Coupler Tester to 100% "UP" (blue).
20. Zero voltage meter on 66D141-2 Power Section by rotating Attitude Gyro knob on 66D141-1 Gyro Substitute to pitch "up". Allow needle to stabilize.
21. Record degrees required to zero needle.
22. With red button on glide slope coupler still depressed rotate Radio Signal Substitute knob for 100% DOWN (yellow).
23. Zero voltage meter on 66D141-2 Power Section by rotating Attitude Gyro knob on 66D141-1 Gyro Substitute "pitch down". Allow about 1 1/2 minutes for needle to stabilize.
24. Record degrees required to zero needle. Total spread between up and down should be $7^{\circ} \pm 1^{\circ}$. Release red button. If not within tolerance, check output of phase detector at the junction of C-11 and R-26. Adjust R-17 for 4V positive or negative with the Radio Signal Substitute set for 60% up or down.
25. With Radio Substitute Signal at 100% down (yellow) rotate Attitude Gyro knob on 66D141-1 to "pitch down" until voltage meter on 66D141-2 Power Section is zero (centered). Allow time for needle to stabilize
26. Record degrees required to zero needle.
27. With Radio Substitute Signal at 100% up (blue) rotate Attitude Gyro knob on 66D141-1 to "pitch up" until voltage meter on 66D141-2 Power Section is zero (centered). Allow time for needle to stabilize.
28. Record degrees required to center needle.
29. Total spread should not exceed $10^{\circ} \pm 2^{\circ}$.
30. Push Radio Signal Substitute knob in (OFF).

D. Integrator Rate Test:

1. Depress red button on 1C493 glide slope coupler and pull out (ON) Radio Signal Substitute on 66D141-4 Coupler Tester.
2. Adjust Radio Signal Substitute for a 20% up (blue) indication.
3. Release red button and allow exactly one (1) minute for integration to stabilize.
4. Reverse Radio Signal Substitute to 20% down (yellow) and observe voltage meter on 66D141-2 Power Section as it passes through zero (0) on the scale.
5. The time required for the voltage meter needle to pass through zero (0) should be 15 to 35 seconds. Start timing at the moment the Radio Signal is reversed.
6. Center Attitude Gyro knob on 66D141-1 Gyro Substitute.
7. With red button on glide slope coupler depressed, center voltage meter on 66D141-2 Power Section by adjusting pot next to red button.
8. Continue to hold red button in and rotate Attitude Gyro knob on 66D141-1 Gyro Substitute toward "pitch down" to zero voltage meter on 66D141-2 Power Section.
9. Pitch down angle should be 2° .

This completes the 1C493 glide slope coupler bench set-up and test.

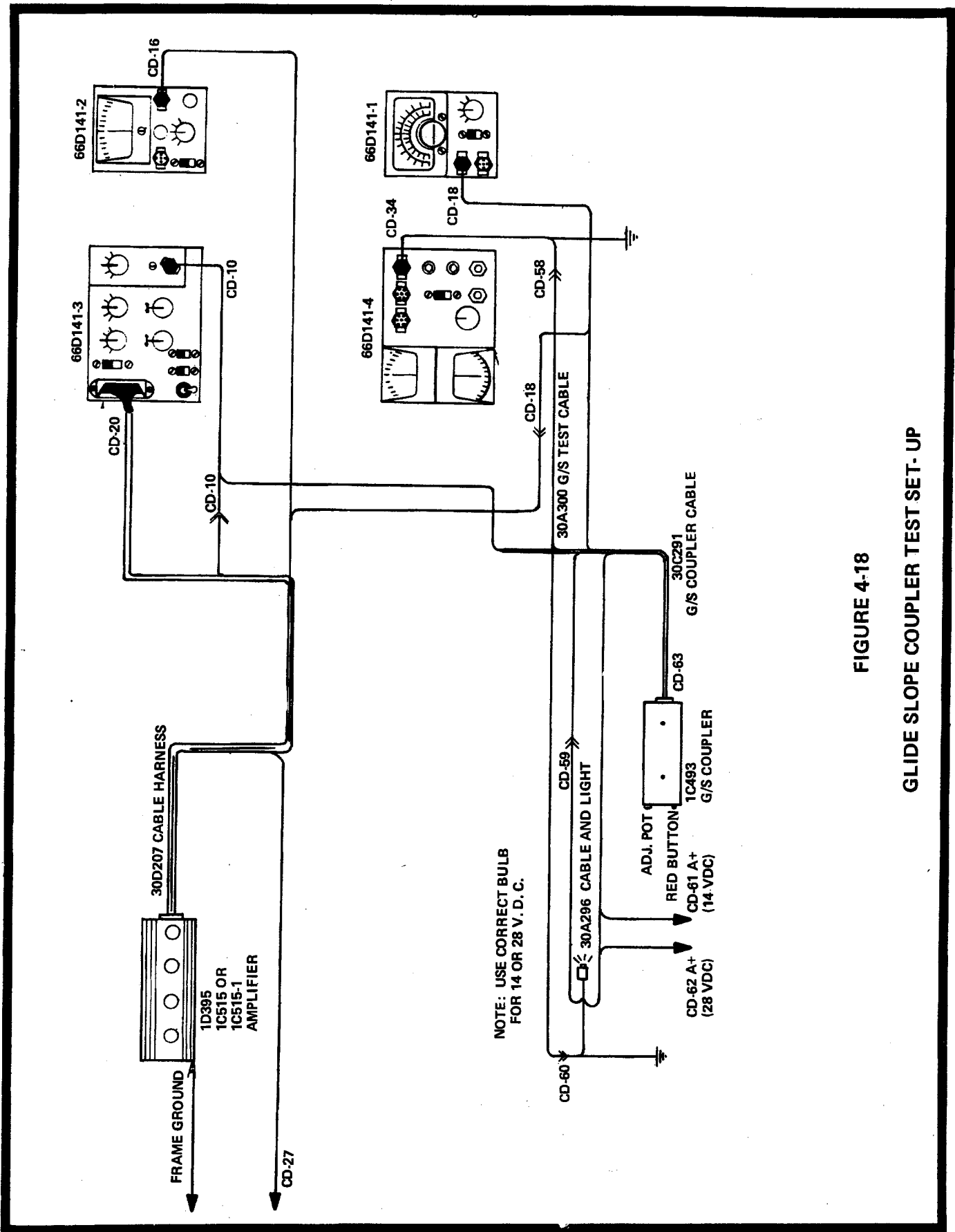

FIGURE 4-18
GLIDE SLOPE COUPLER TEST SET-UP

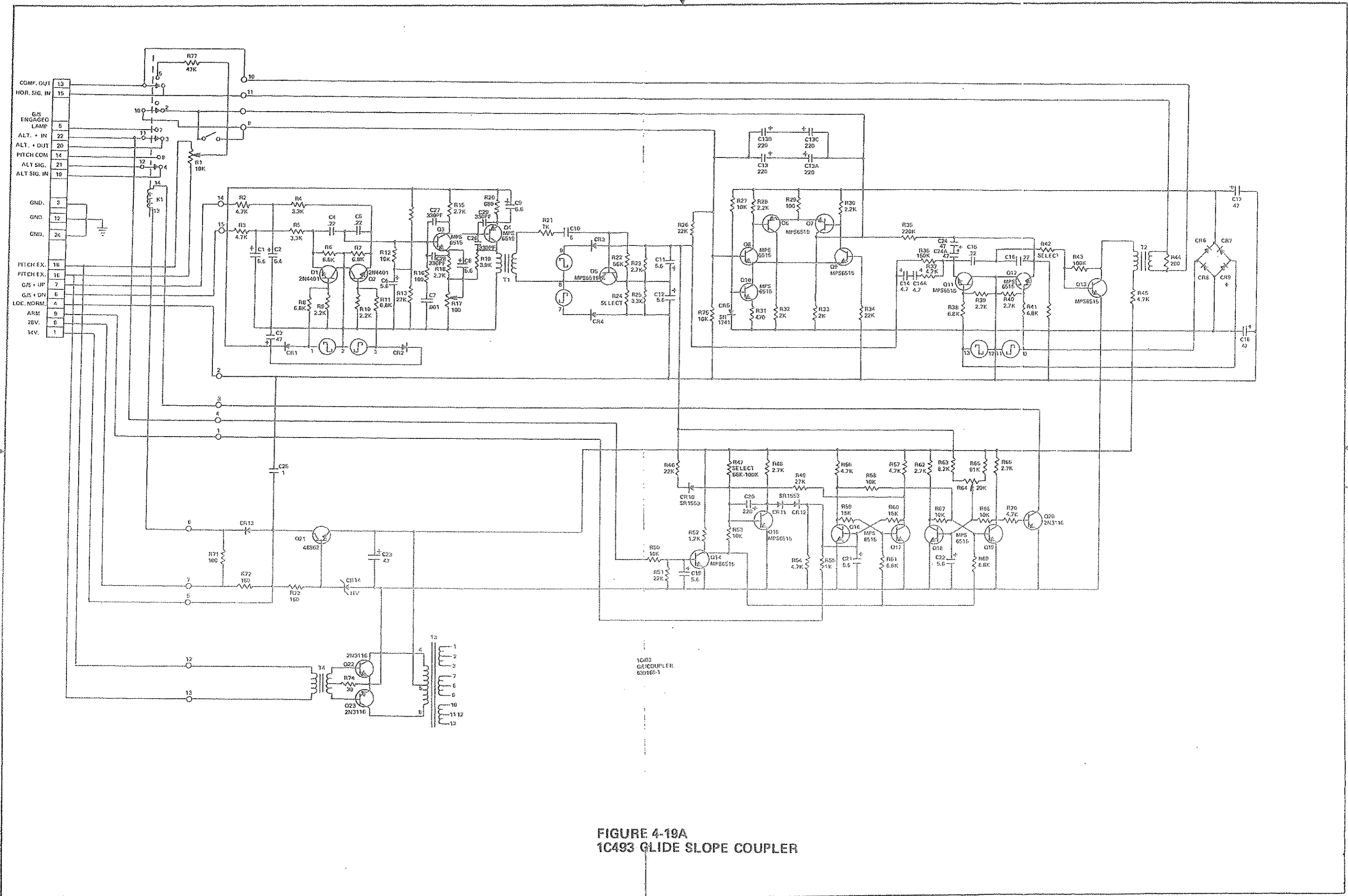

FIGURE 4-19A
1C493 GLIDE SLOPE COUPLER

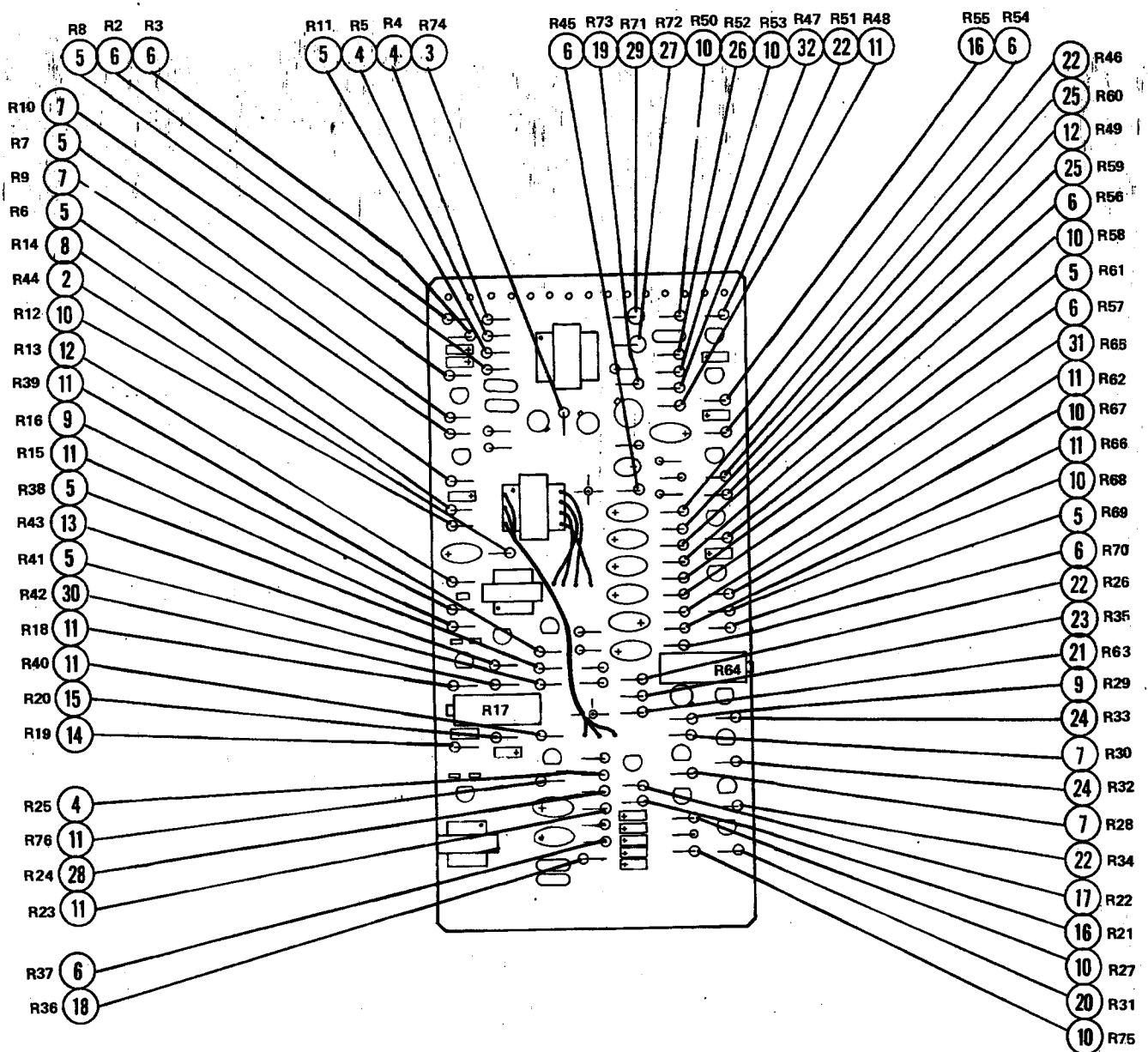

FIGURE 4-19B

GLIDE SLOPE COUPLER PRINTED CIRCUIT BOARD

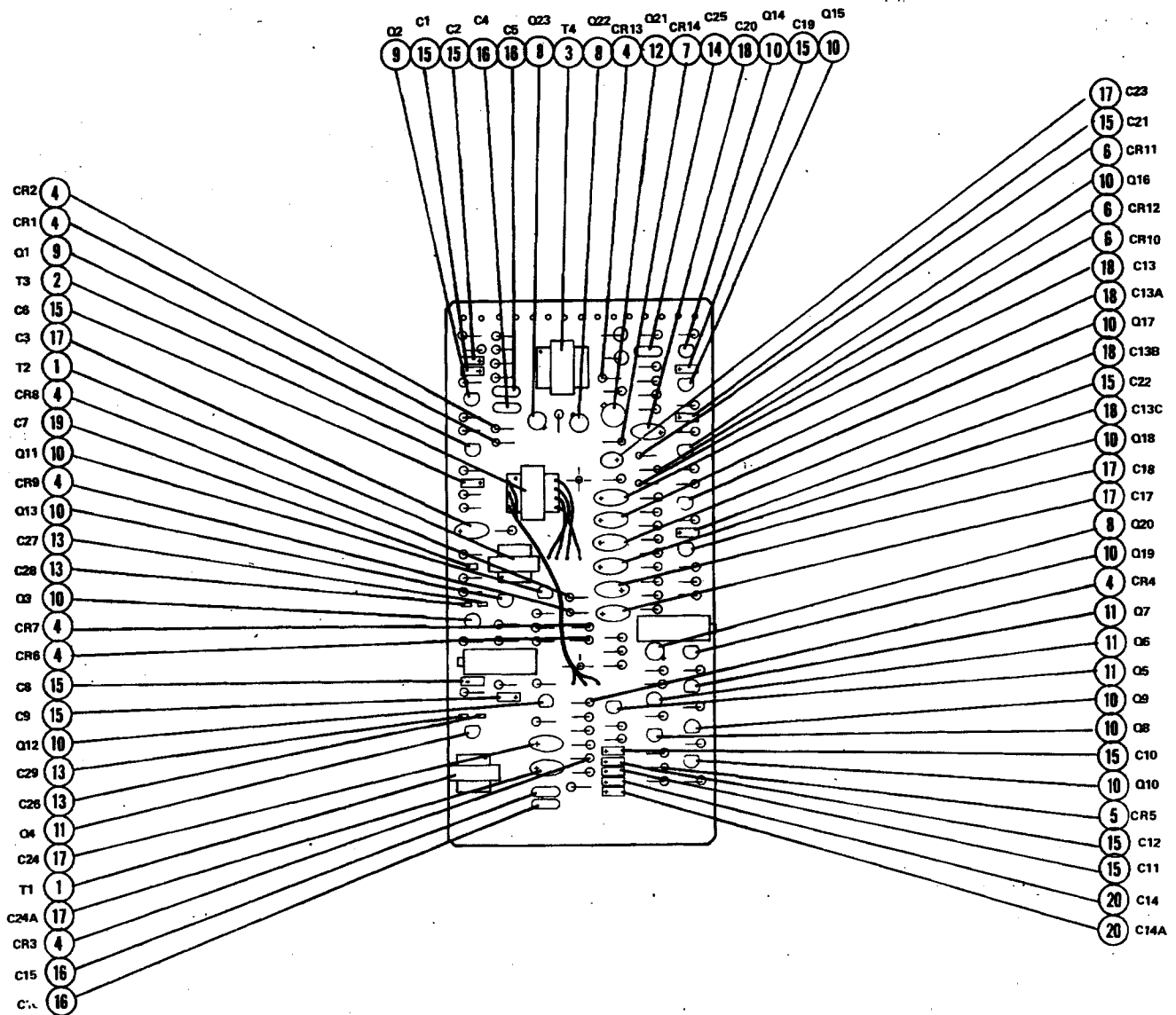

FIGURE 4-19B (CONTD)

GLIDE SLOPE COUPLER

4.8 TRIM AMPLIFIER - 79C54 & 79C53

Pitch trim amplifiers Part Number 79C54 are used with the push button automatic trim systems with single contact trim sensors. The 79C54 Amplifiers are used with single contact trim sensors and a switch that commands the direction of trim.

The trim system operates automatically while the autopilot is on (Pitch or Alt. mode). A switch in the Century III console provides A+ to the trim amplifier through pin H of CD-45. Ref. Fig. 4-20.

When the aircraft is out of trim, the pitch trim sensor provides a ground to pin A or B of CD-45 in relation to which direction it is out of trim.

Pin A of CD-45 is connected directly to the base of Q-1 which is operating as a switch. Bias through R-1 keeps Q-1 turned on and the collector voltage will be near ground potential. When Pin A is grounded by the trim sensor, the base of Q-1 is grounded and the collector will start to go positive. Q-11 and C-1 make up an integrator that will allow the voltage on the collector of Q-1 and the base of Q-13 to rise almost to the A+ value in about 3 seconds. This time delay keeps the trim from running excessively by requiring an out of trim condition for approximately 3 seconds before trimming. As the voltage rises on the collector of Q-1, Q-3 and Q-5 drive Q-7, putting a positive voltage on one side of the trim motor (CD-13, pin C). Also through D-1 and D-3 a positive signal is felt as the base of Q-14 which is turned on clamping the other side of the motor (CD-73, pin D) to ground through its emitter-collector junction. With pin C positive and pin D negative, the trim motor will run until the pressure on the elevator cables is equal again and the trim sensor opens the ground to pin A of CD-45. Opening the ground on Q-1 restores the bias and brings the voltage on the collector bank to ground potential turning off the amplifier.

The other half of the amplifier operates the same when pin B of CD-45 is grounded causing the motor to run in the opposite direction.

With the autopilot off, (79C54), the push button on the control wheel, is used to activate the trim system. When the button is pressed, A+ is applied through pin E of CD-45 and the isolation diode D-5 to the amplifier. In the amplifier, A+ is applied to the bases of Q-9 and Q-10, switching them on. These transistors hold the negative side of C-1 and C-2 at ground eliminating any integrator time delay. Therefore, the trim motor will run immediately when the control wheel button is pressed and the trim sensor provides a ground.

Trim Amplifiers, 79C53 (Fig. 4-21), are basically the same as the 79C54. A relay is added to the 79C53 to allow the pilot to use a switch on the control wheel to command the direction of trim. Because the amplifier is used only with the autopilot on, there is no need for extra circuits to eliminate the time delay (as Q-9 and Q-10 in the 79C54) for manual operations.

Trim Amplifiers 79C54-3 (used only in Aerostars) are the basic 79C54 with an added test and malfunction circuit. If the amplifier time delay malfunctions, the test circuit will energize a relay that interrupts autopilot A+, shutting it off. The press-to-test signal causes a time delay malfunction to test the circuit.

From the base of Q-3 or Q-4 (Fig. 4-20), a slowly rising signal (see 79C54 text), is coupled through C-5 or C-6 and R-12 to ground. While the time delay is operating normally the voltage developed across R-12 will not be large enough to turn Q-15 on. If the time delay malfunctions where the trim runs as soon as the trim sensor calls for it, the voltage on Q-3 or Q-4 will rise al-

most instantly. This signal coupled through C-5 or C-6 will cause Q-15 to turn on. This causes Q-16 to turn off and Q-17 and Q-18 to turn on. The collector of Q-18 is connected to the autopilot interrupt relay and will energize the relay turning the autopilot off.

When the press-to-test button is pressed, A+ through R-11 and R-21 will eliminate the time delay by turning Q-9 and Q-10 on.

4.9 TRIM AMPLIFIERS 1C646 AND 1C671

Trim Amplifiers 1C646 and 1C671 are basically the same as the 79C54 amplifier except they are used with dual contact trim sensors. Each amplifier has two extra transistors that control the side of the amplifier that grounds one side of the motor (Q-1 and Q-15, Fig. 4-22, Q-1 and Q-14 Fig. 4-23). The extra set of contacts on the sensor switch the two added transistors. Both contacts have to provide grounds in the same direction before the amplifier will start the trim motor.

The 1C646 Amplifier is used with the push button automatic type with dual contact sensors.

The 1C671 Amplifier is used with the command automatic type trim system where the switch on the control wheel commands the direction of trim.

4.10 TRIM AMPLIFIERS 1B369 AND 1B389:

Early trim systems used trim amplifiers mounted on the pitch servo. 1B369 (28V) and 1B389 (14V) amplifiers, used a single contact trim sensor and had push button, manual trim.

In the autopilot mode, A+ from CD-40, pin B (see Fig. 4-24) is applied to the amplifier through CD-45, pin H. The trim solenoid will engage but nothing else happens until the trim sensor provides a ground. When CD-45, pin B, is grounded by the trim sensor, the collectors of Q-5 and Q-7 are grounded. Q-7 will remain turned off until C-1 charges through R-9 and CR-1. This time delay keeps the trim from running excessively. When C-1 charges Q-7, Q-5 and Q-3 will turn on clamping one side of the trim motor to ground. The ground on one side of the motor will cause Q-2 to turn on by completing a bias path through R-4 and R-2. Q-2 clamps the other side of the motor to A+ which re-trims the aircraft and removes the ground from the trim sensor. The other half of the amplifier operates the same when CD-45, pin D, is grounded.

When the autopilot is off, the pilot depresses the control wheel switch which applies A+ to CD-45, pin E. Diodes CR-3 and CR-4 isolate C-1 and C-2 eliminating the time delay. The trim will start to run as soon as the trim sensor provides a ground.

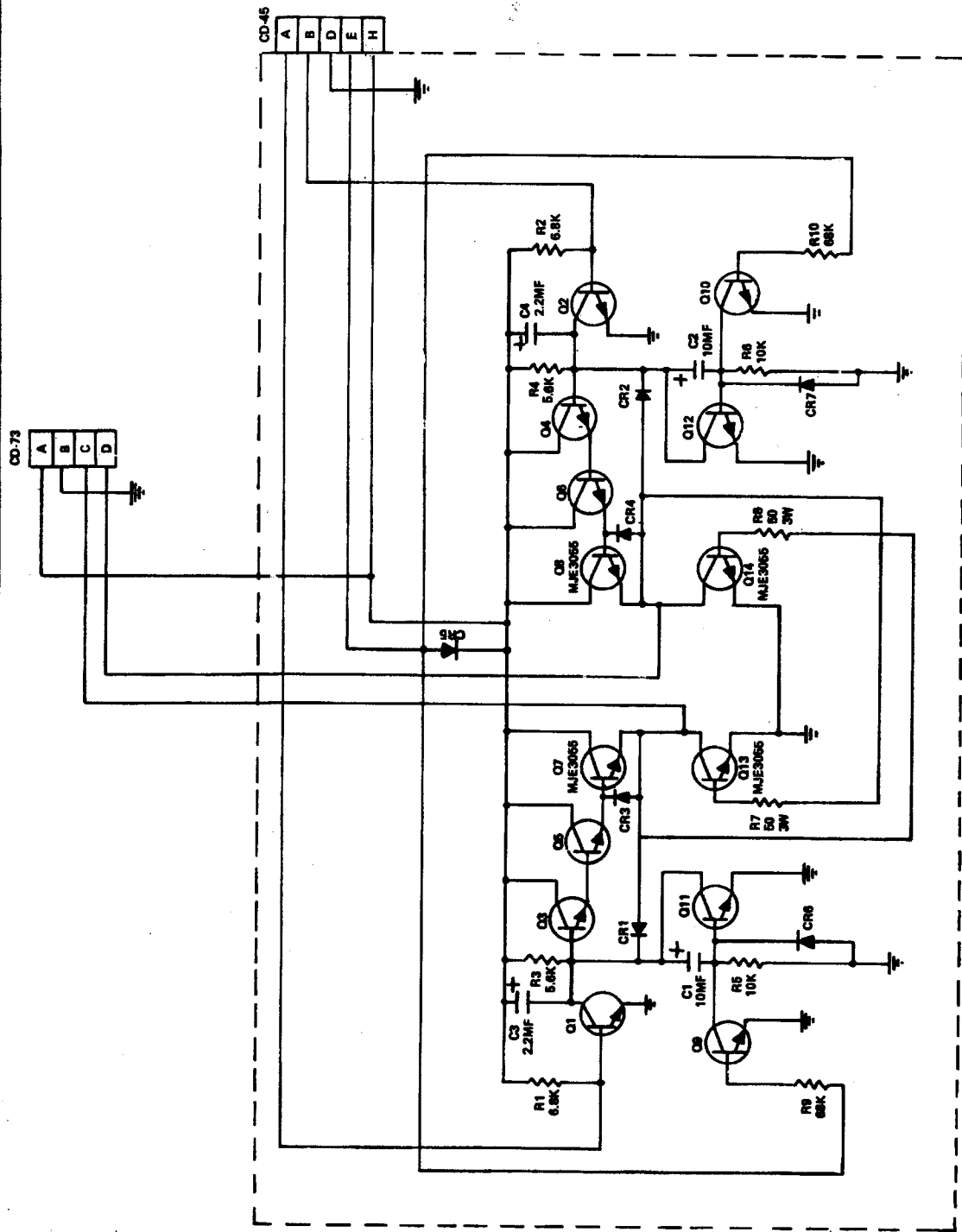

- NOTES:
1. ALL RESISTORS ARE 1/2 WATT UNLESS OTHERWISE SPECIFIED.
 2. ALL DIODES ARE 1N4001 UNLESS OTHERWISE SPECIFIED.
 3. ALL TRANSISTORS ARE 2N4001 UNLESS OTHERWISE SPECIFIED.
 4. DASH-1 14VDC AMPLIFIER SHOWN. FOR DASH-2 SUBSTITUTE THE FOLLOWING:
R7, R8: 220, 3 WATT
R9, R10: 22K, 1/2 WATT

FIGURE 4-20A
TRIM AMPLIFIER 79C54 SCHEMATIC

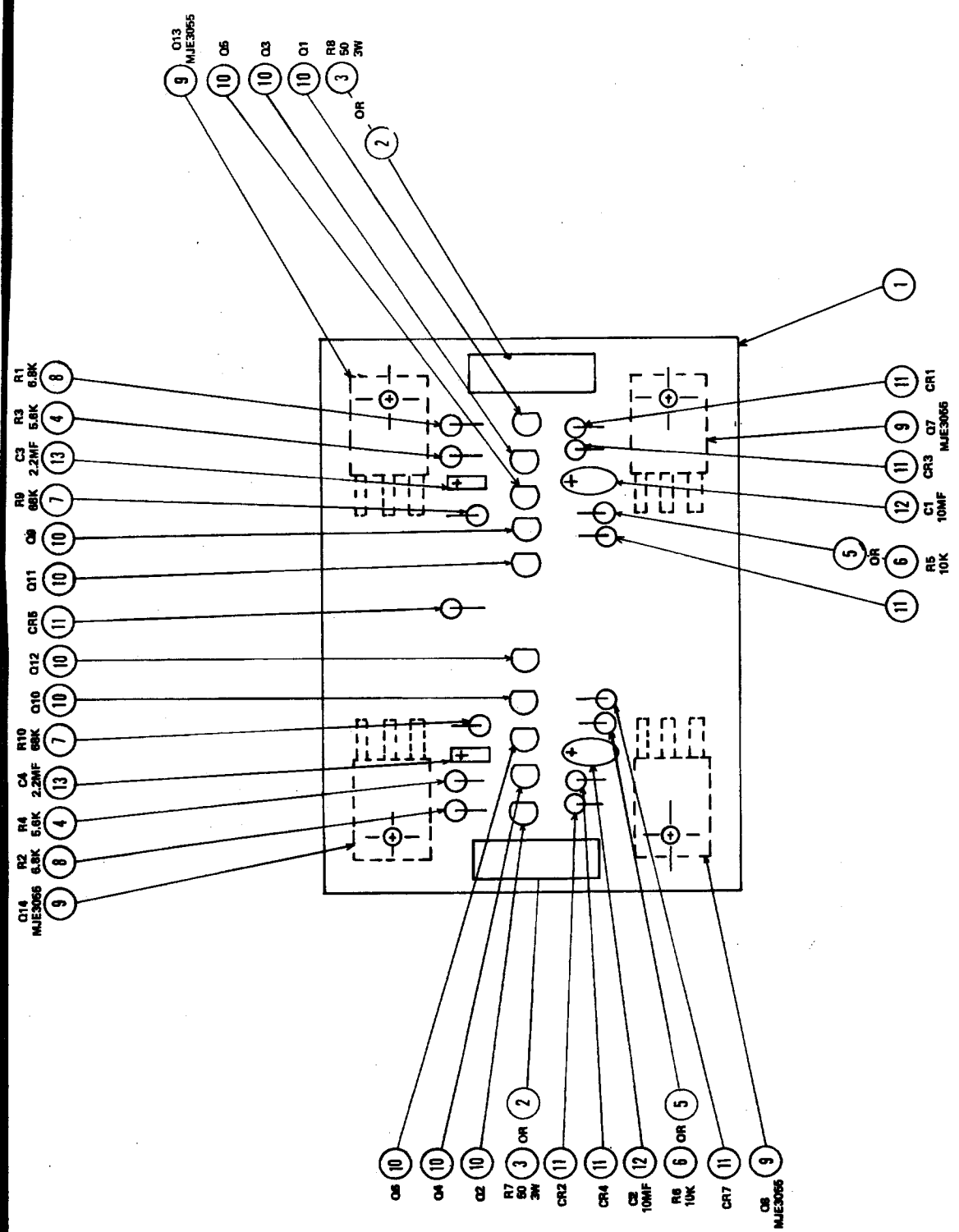
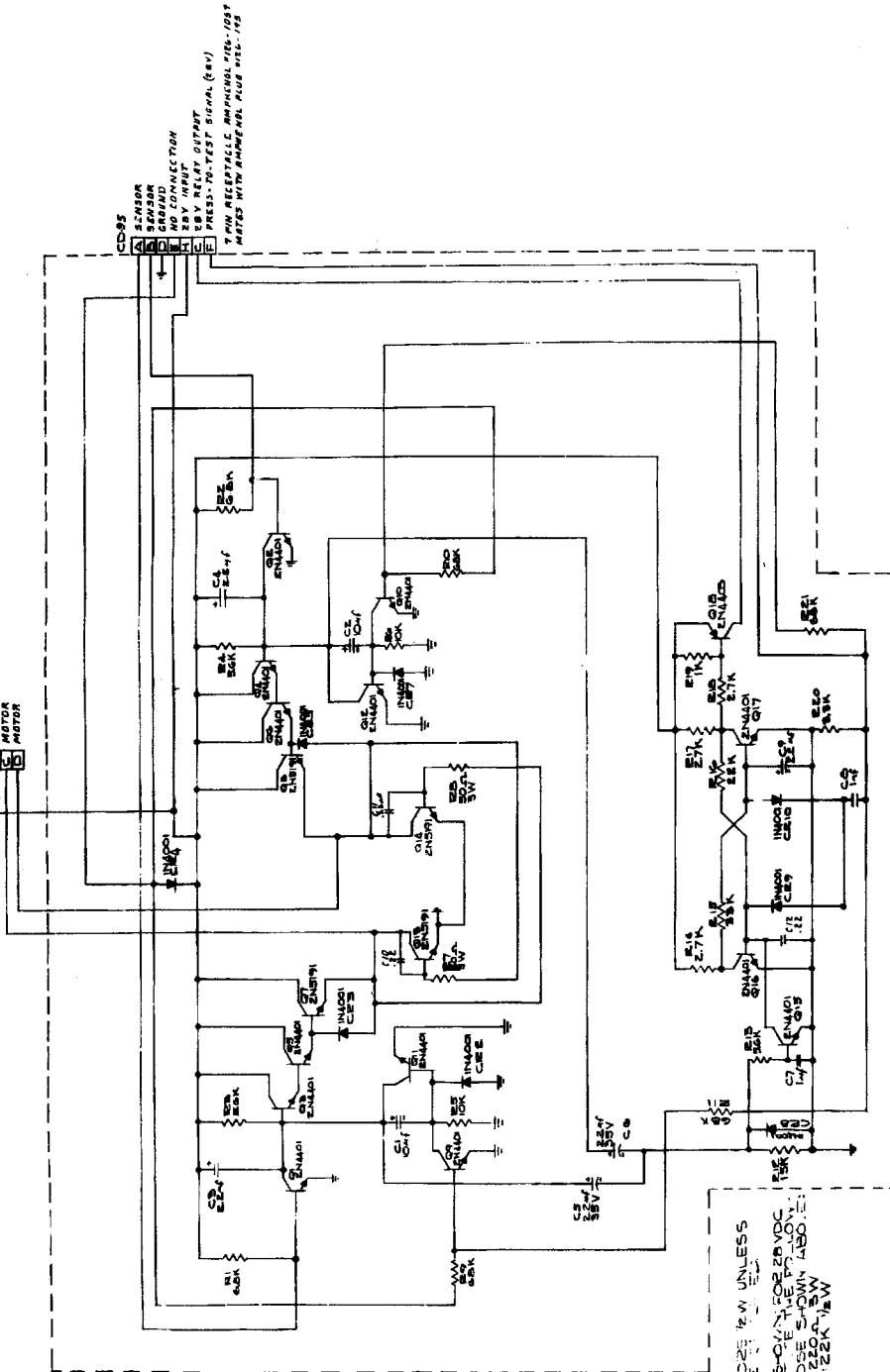

FIGURE 4-20B
 TRIM AMPLIFIER 79C54 P. C. B. & -3 P. C. B.

15V PLUS SIGNAL FROM 79C54-3
MATES WITH AN ANALOG RECEPTACLE 79A-118

CD-75
SOLENOID
GROUND
MOTOR

CD-85
SENSOR
GROUND
NO CONNECTION
5V VBAT
PRESS-TO-TEST SIGNAL (5V)
15V RESETABLE ANALOGICAL 79C-1037
MATES WITH AN ANALOGICAL 79A-118



NOTES:

1. ALL RESISTORS ARE 1/4 W UNLESS OTHERWISE SHOWN.
2. ALL CAPACITORS ARE POLARIZED UNLESS OTHERWISE SHOWN. ABSOLUTE VALUES ARE SHOWN UNLESS OTHERWISE SHOWN.

FIGURE 4-20C
TRIM AMPLIFIER 79C54-3 SCHEMATIC

FIGURE 4-21A
TRIM AMPLIFIER 79C53 SCHEMATIC

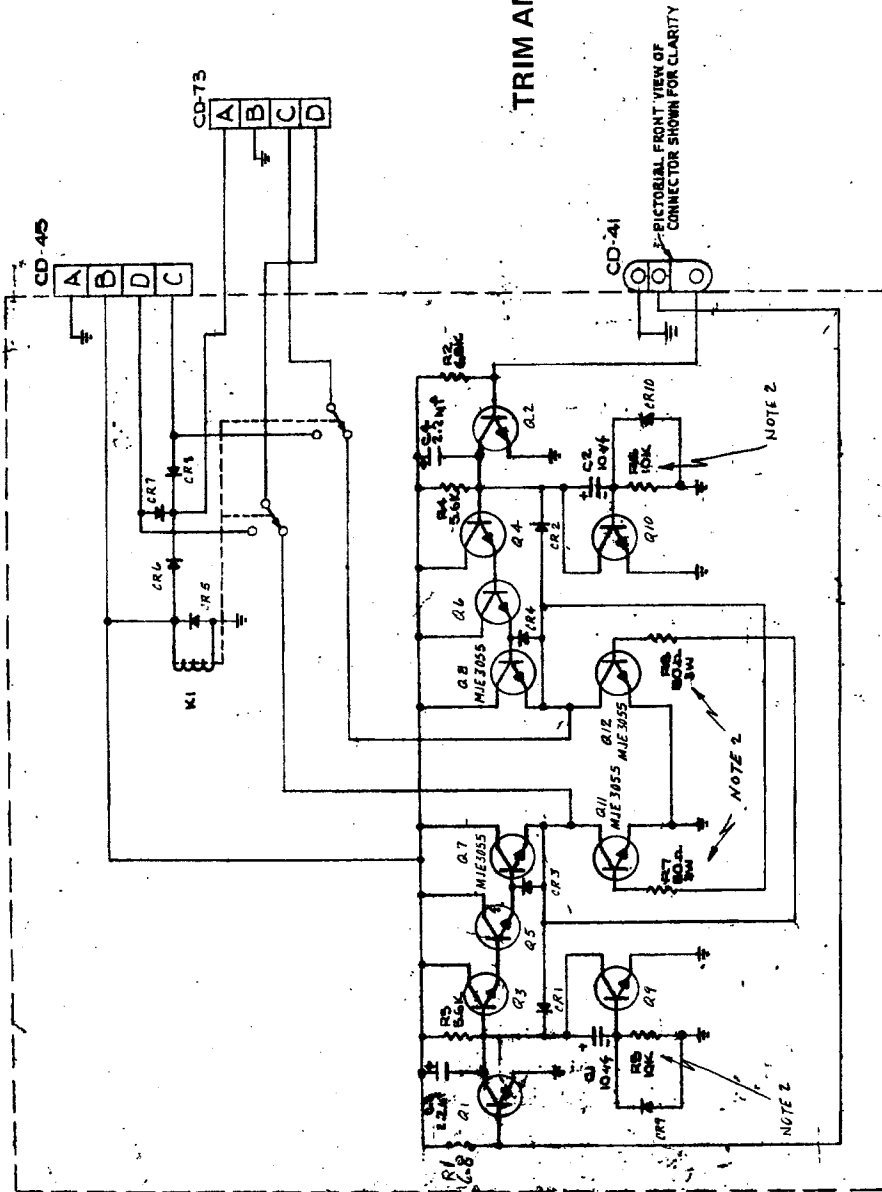

- NOTES:
 1. ALL RESISTORS 1/8W UNLESS SPECIFIED OTHERWISE.
 2. ALL CAPACITORS 50VDC UNLESS SPECIFIED OTHERWISE.
 3. ALL DIODES ARE 1N4001 UNLESS OTHERWISE SPECIFIED.
 4. ALL TRANSISTORS ARE 2N4401 UNLESS OTHERWISE SPECIFIED.

K1			
Q1			
Q2			
Q3			
Q4			
Q5			
Q6			
Q7			
Q8			
Q9			
Q10			
CR1			
CR2			
CR3			
CR4			
CR5			
CR6			
CR7			
CR8			
C1			
C2			
C3			
C4			
FR10			
FR11			
FR12			
FR13			
FR14			
FR15			
FR16			
FR17			
FR18			
FR19			
FR20			
FR21			
FR22			
FR23			
FR24			
FR25			
FR26			
FR27			
FR28			
FR29			
FR30			
FR31			
FR32			
FR33			
FR34			
FR35			
FR36			
FR37			
FR38			
FR39			
FR40			
FR41			
FR42			
FR43			
FR44			
FR45			
FR46			
FR47			
FR48			
FR49			
FR50			
FR51			
FR52			
FR53			
FR54			
FR55			
FR56			
FR57			
FR58			
FR59			
FR60			
FR61			
FR62			
FR63			
FR64			
FR65			
FR66			
FR67			
FR68			
FR69			
FR70			
FR71			
FR72			
FR73			
FR74			
FR75			
FR76			
FR77			
FR78			
FR79			
FR80			
FR81			
FR82			
FR83			
FR84			
FR85			
FR86			
FR87			
FR88			
FR89			
FR90			
FR91			
FR92			
FR93			
FR94			
FR95			
FR96			
FR97			
FR98			
FR99			
FR100			

NO.	REVISION	DATE BY	TOLERANCES UNLESS OTHERWISE SPECIFIED	DRAFTSMAN	DATE	SCALE
1	REL. PER E.O. 6183	11-16-71	UNLESS OTHERWISE SPECIFIED	C. WILSON	11-22-71	1:1
2	REVISION PER E.O. 11644	11-19-71	DECIMAL ± N/A	C. W. W.	11-29-71	1:1
		11-19-71	FRACTIONAL ± N/A	ENGINEER	12-1-71	1:1
		11-19-71	ANGULAR ± N/A		3-10-72	1:1
			DO NOT SCALE PRINT			

APPLICATION: SCHEMATIC, PITCH TRIM AMPLIFIER, 14-28VDC (PIPER)
 USED ON: 79C53
 NEXT ASSY NUMBER: 79C53-1
 MITCHELL INDUSTRIES INC., MINERAL WELLS, TEXAS
 SHEET 1 OF 1

FIGURE 4-21B

TRIM AMPLIFIER 79C53 P. C. B.

W. J. L. S. SCHEMATA 79C 30/73

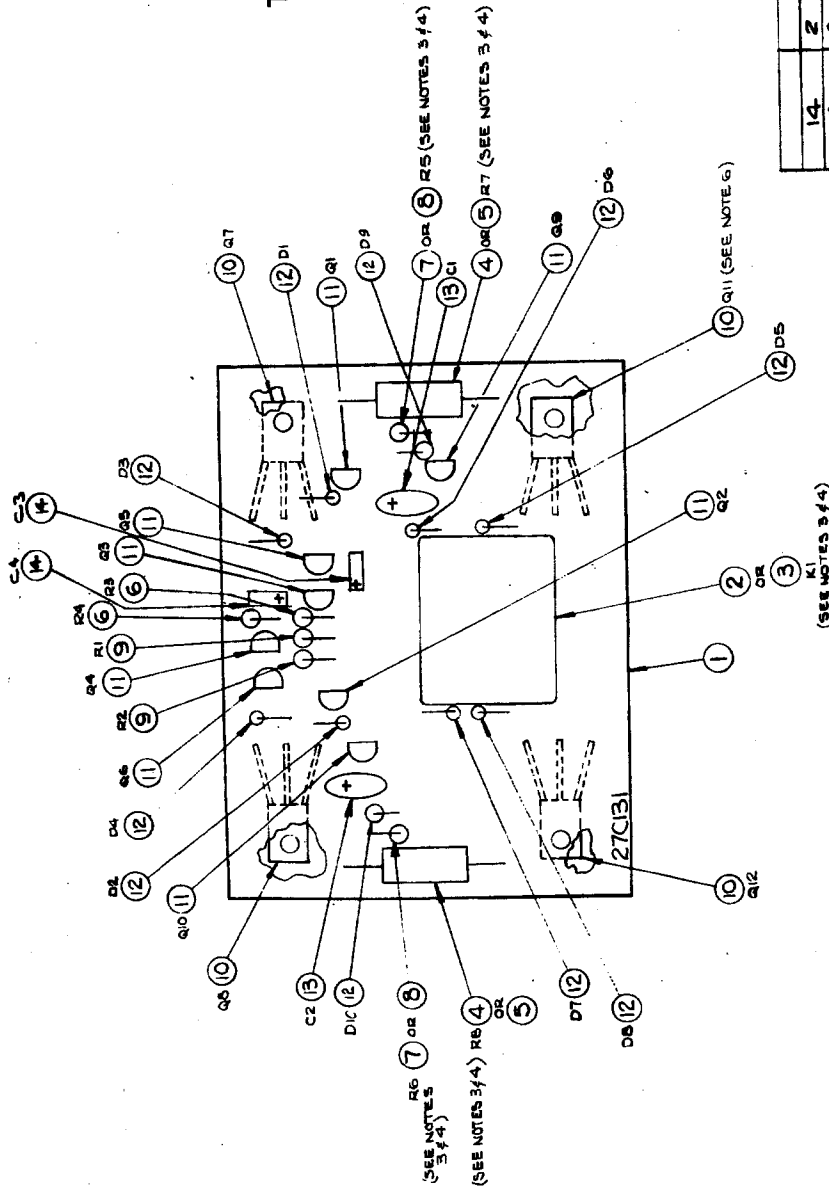

- NOTES:
- 79C70-1 IS 14VDC UNIT
 - 79C70-2 IS 28VDC UNIT
 - USE ITEMS # 2, 4 & 7 FOR 14VDC UNIT (REF)
 - USE ITEMS # 3, 5 & 8 FOR 28VDC UNIT (REF)
 - STORE MICA DISCS THAT COME WITH TRANSISTORS, FOR USE AT NEXT ASSY. 79C53-1-2 BE INSTALLED WITH THEIR COPPER SIDE AWAY FROM BOARD (ITEM 1)
 - INSTALL ALL ITEM 12 WITH CATHODE (FROM) NEXT TO BOARD.
 - REFERENCE FOR ATR SUBSTITUTION OF CARBON RESISTOR.

ITEM NO.	QTY	PART NO.	ZONE	DESCRIPTION
14	2	21A88		CAPACITOR, 2.2 MF, 35 WVDC, ± 20%
13	2	21S151		CAPACITOR, 10 MF, 35 WVDC, TANTALUM
12	10	48S33		DIODE (1N4001)
11	8	48S69		TRANSISTOR (2N4401)
10	4	48A68		TRANSISTOR (2N5931)
9	2	6368222		RESISTOR, 5K, 1/4W, 2%
8	2	6368224		RESISTOR, 22K, 1/4W, 2%
7	2	6368224		RESISTOR, 10K, 1/4W, 2%
6	2	6368224		RESISTOR, 5.6K, 1/4W, 2%
5	2	GR215		RESISTOR, 220Ω, 3W, ± 5%
4	2	GR214		RESISTOR, 50Ω, 3W, ± 5%
3	1	80S70		RELAY (24VDC)
2	1	80S77		RELAY (28VDC)
1	1	27C131		P.C. BOARD

NO	REVISION	DATE	BY	TOLERANCES UNLESS OTHERWISE SPECIFIED
A	REVISED	3-27-68	J. D. DUNN	
B	REVISED	3-27-68	J. D. DUNN	
C	REVISED	3-22-68	J. D. DUNN	
D	REVISED	3-22-68	J. D. DUNN	
E	RESISTOR CHANGE	6-15-73	P. H.	

SCALE: 2:1
 P.C. BOARD ASSY.,
 AMPLIFIER, PITCH TRIM
 SERVOS (PIPER)

MITCHELL INDUSTRIES INC.
 MUNICIPAL AIRPORT, MINERAL WELLS, TEXAS
 79C70-2
 SHEET 1 OF 1

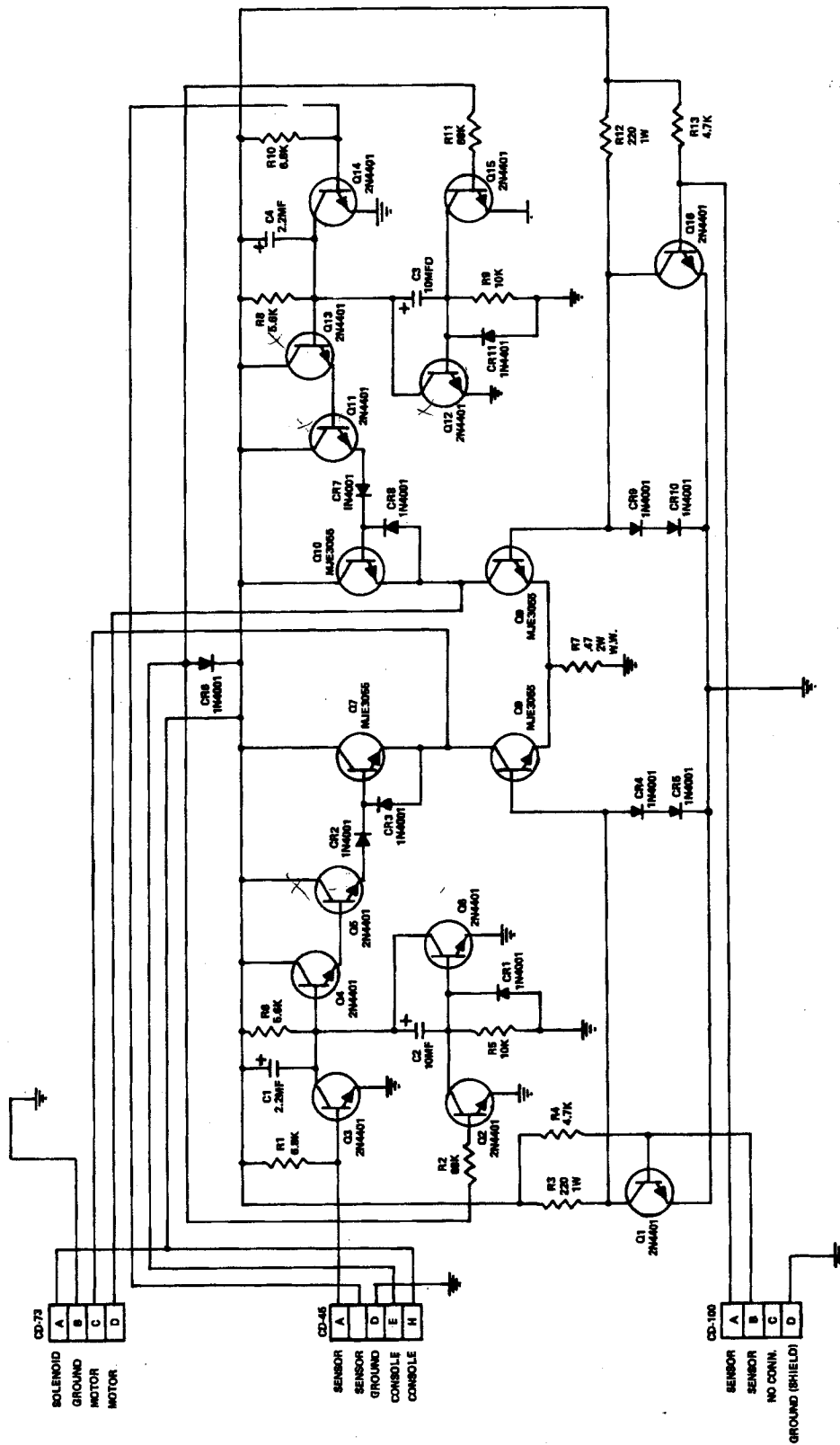

- NOTES:
1. ALL RESISTORS ARE 1/2 WATT UNLESS OTHERWISE SPECIFIED.
 2. DASH-14 14VDC AMPLIFIER SHOWN. FOR 28 28VDC SUBSTITUTE THE FOLLOWING:
 - R5, R9: 22K 1/2 WATT
 - R3, R12: 470 OHM 2 WATT
 - R4, R13: 10K 1/2 WATT

FIGURE 4-22A
TRIM AMPLIFIER 1C646 SCHEMATIC

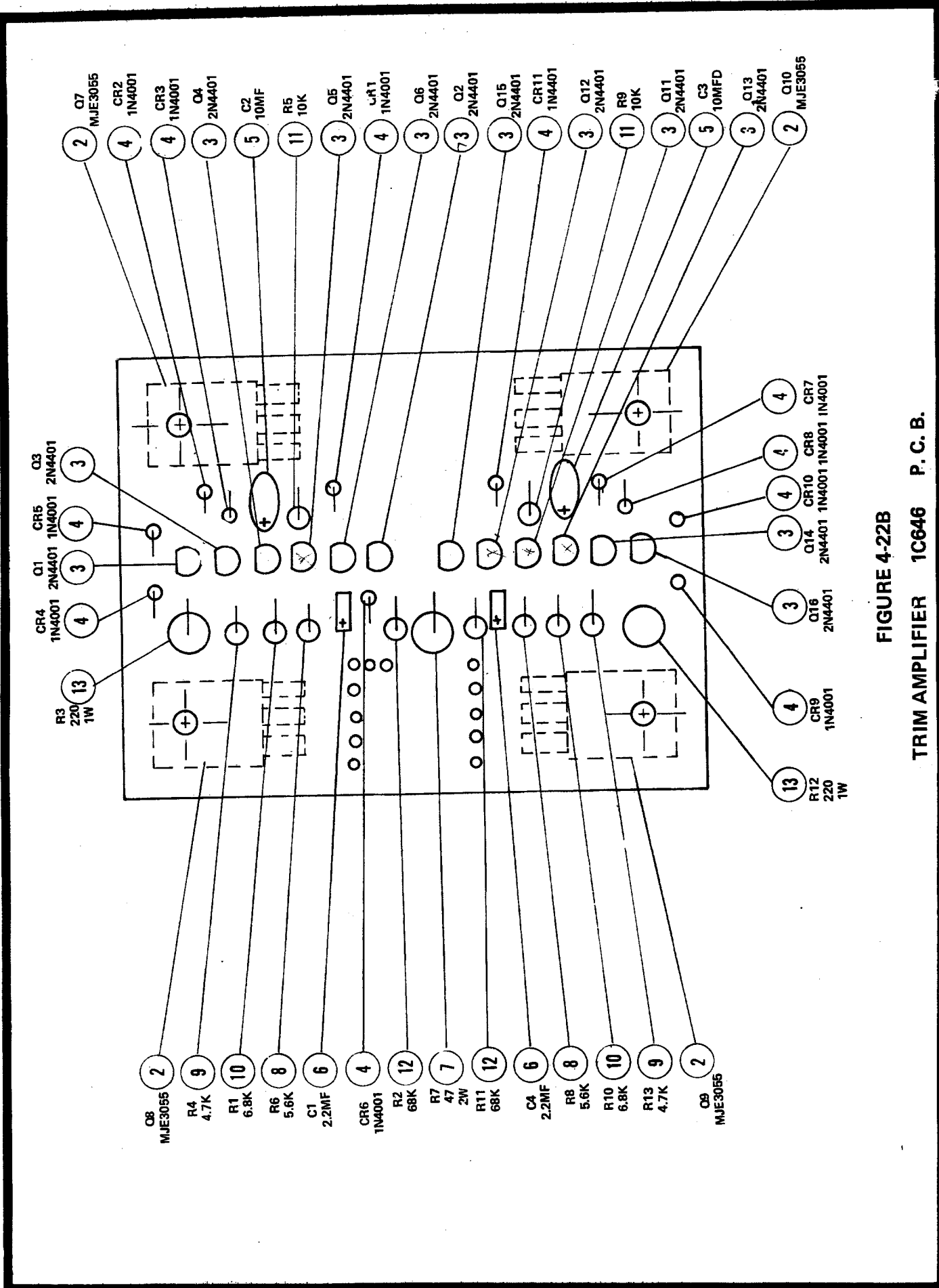
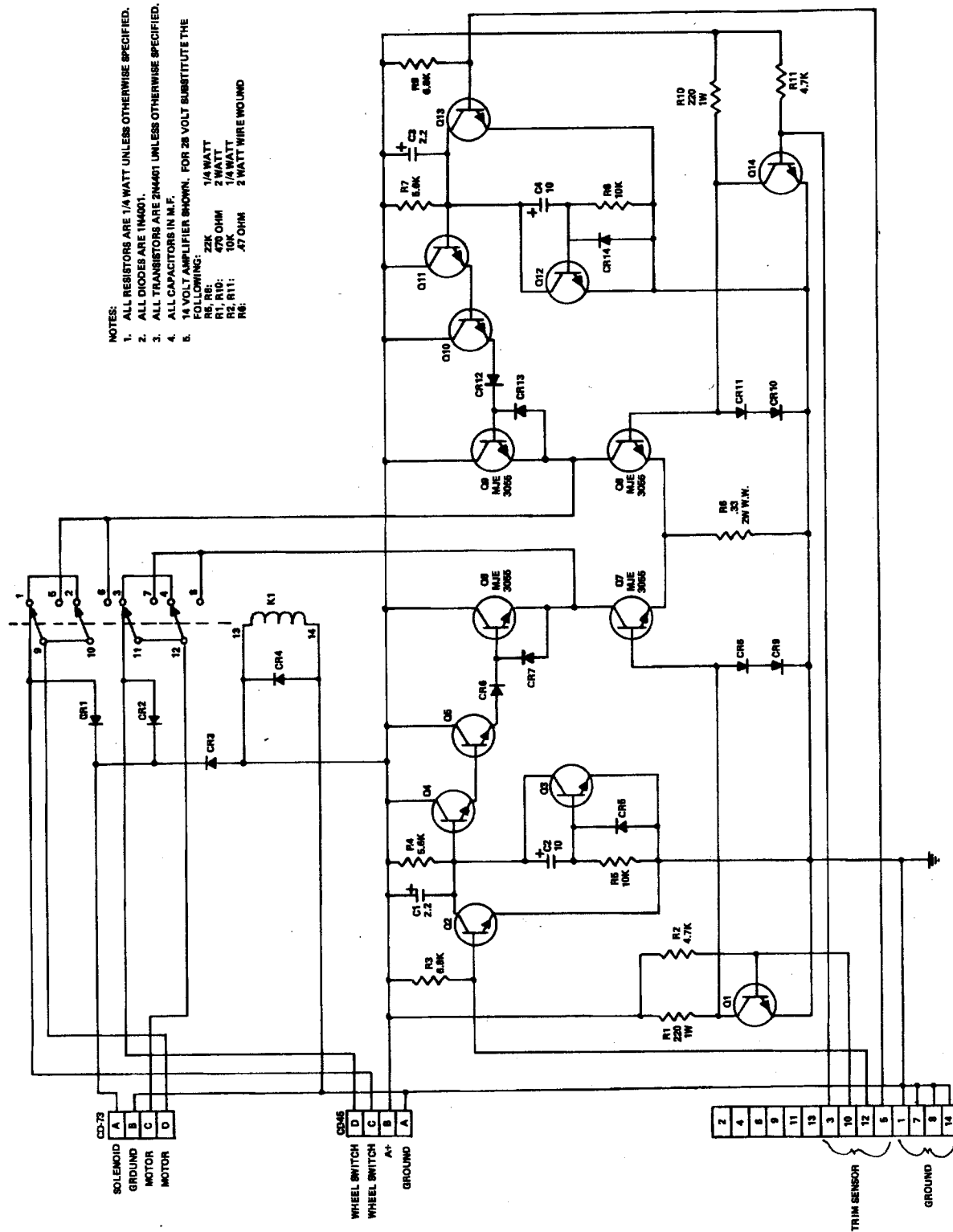

FIGURE 4-22B

TRIM AMPLIFIER 1C646 P. C. B.



- NOTES:
1. ALL RESISTORS ARE 1/4 WATT UNLESS OTHERWISE SPECIFIED.
 2. ALL DIODES ARE 1N4001.
 3. ALL TRANSISTORS ARE 2N4401 UNLESS OTHERWISE SPECIFIED.
 4. ALL CAPACITORS IN M.F.
 5. 14 VOLT AMPLIFIER SHOWN. FOR 28 VOLT SUBSTITUTE THE FOLLOWING:
 - R5, R6: 22K 1/4 WATT
 - R1, R10: 470 OHM 2 WATT
 - R2, R11: 10K 1/4 WATT
 - R8: .47 OHM 2 WATT WIRE WOUND

FIGURE 4-23A
TRIM AMPLIFIER 1C671 SCHEMATIC

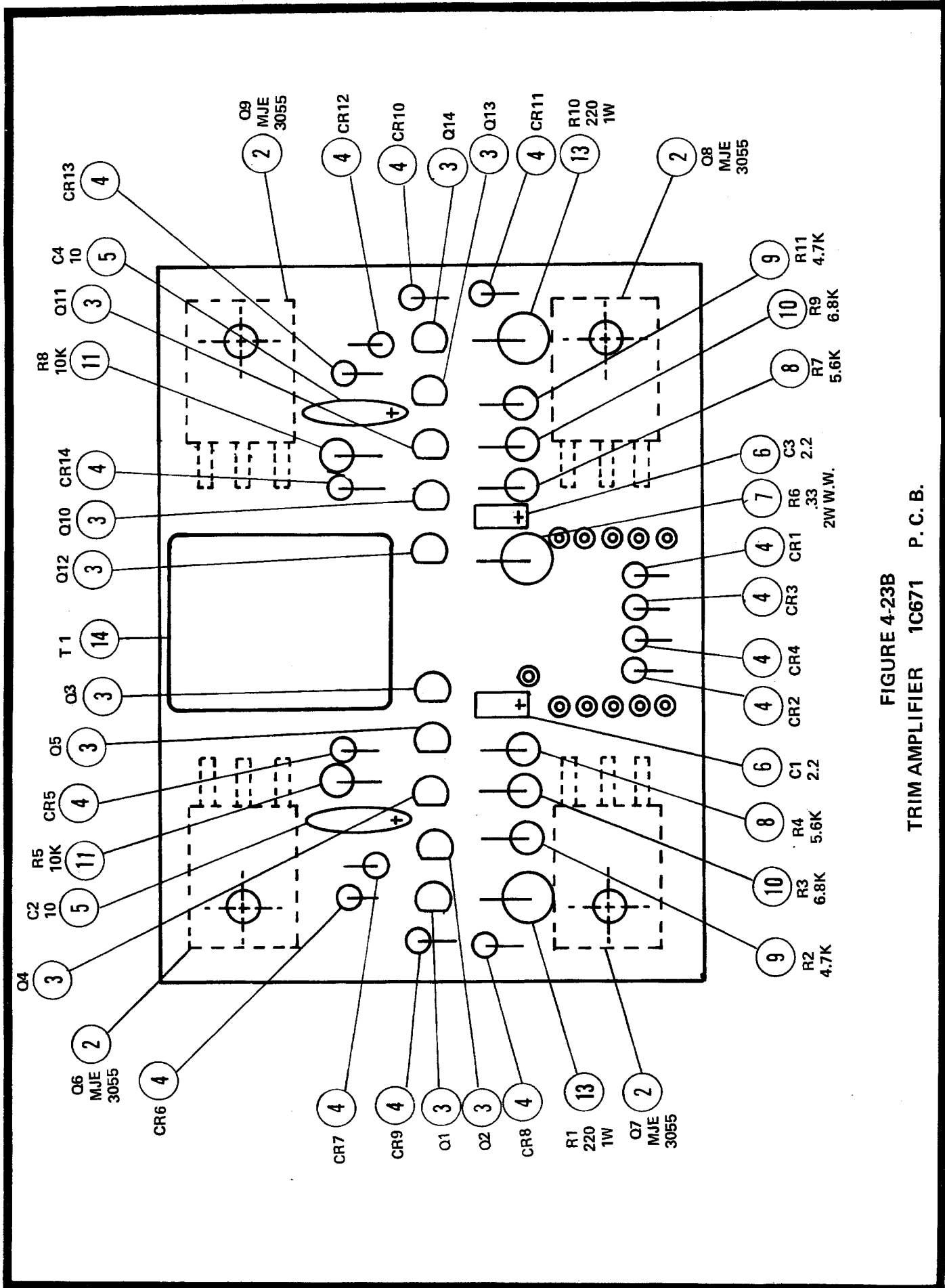

FIGURE 4-23B
 TRIM AMPLIFIER 1C671 P. C. B.

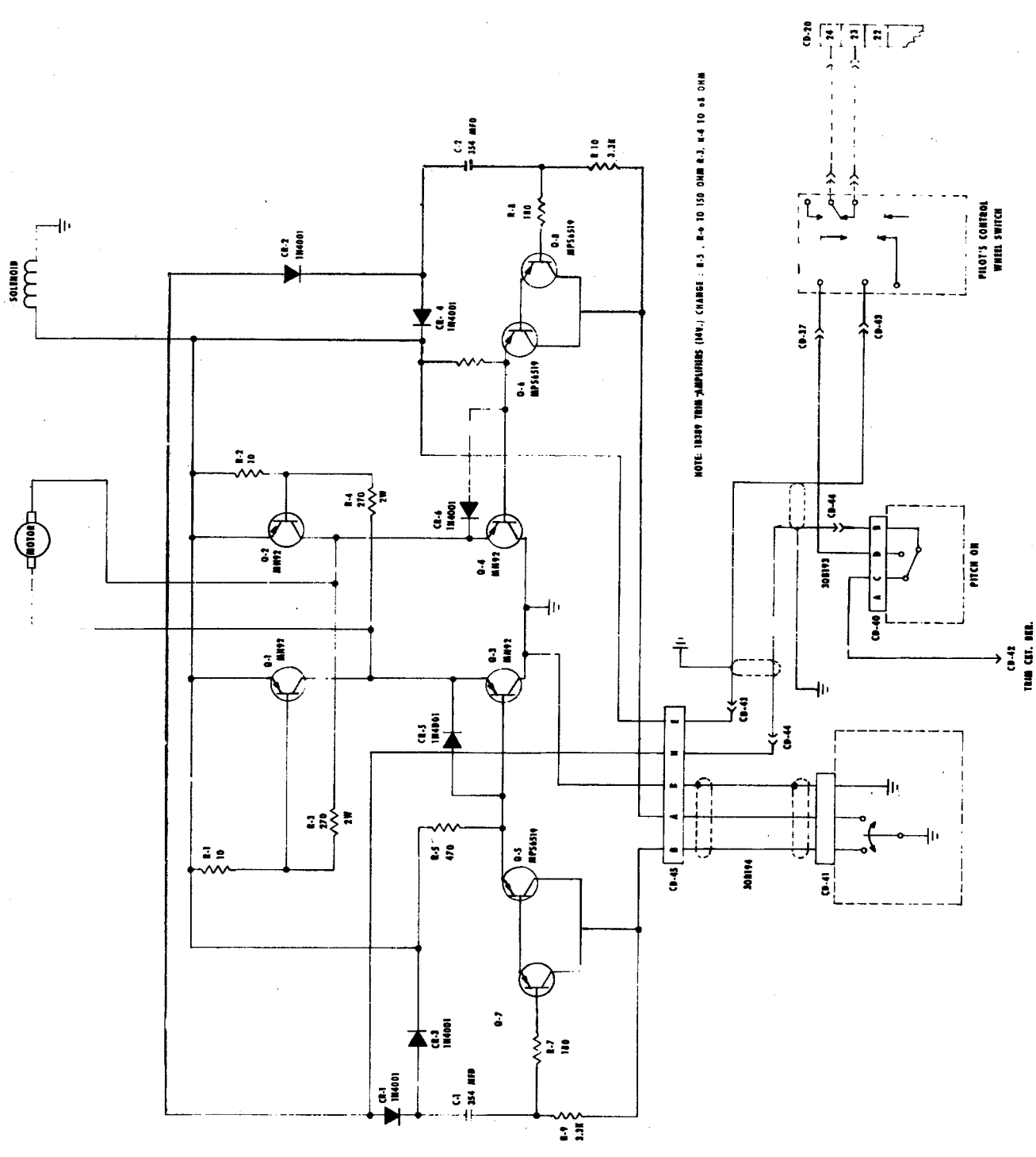

FIGURE 4-24A
TRIM AMPLIFIER 1B369 & 1B389

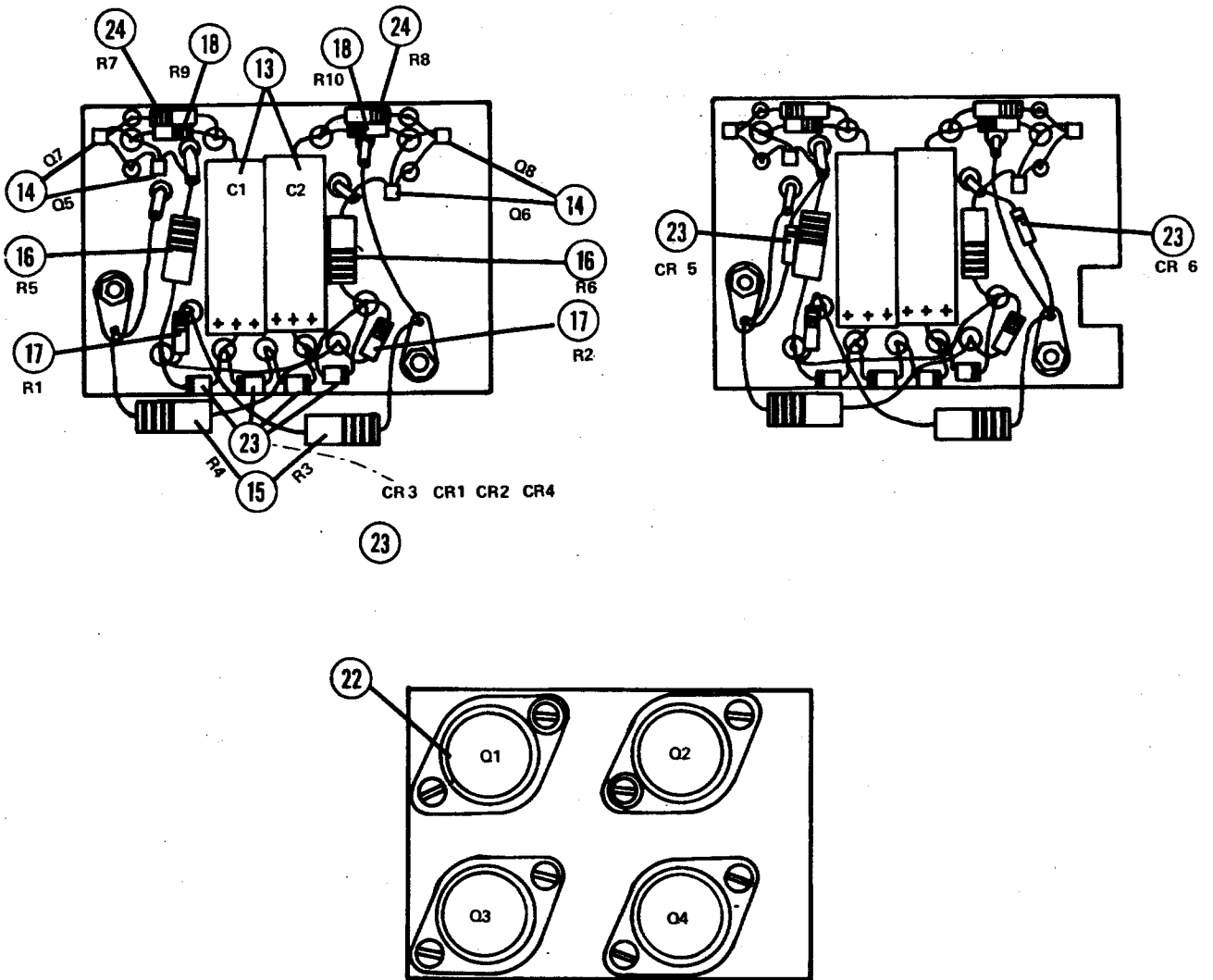

FIGURE 4-24B

TRIM AMPLIFIER 1B369 & 1B389 P. C. B.

4.11 SYNCHRONOUS FILTERS

4.11.1 **Basic Synchronous Filter** - The simplified filter circuit shown in Fig. 4-25(a) consists of a vibrating switch that operates in synchronism with the AC signal to be filtered. Operation is such that the in or out of phase (0° or 180°) component of this signal will be translated into a perfect square wave and all other components of signal or noise, except odd harmonics of the fundamental mentioned above, will be eliminated. Consider the half cycle in which the switch is to the left. During this half cycle the net effect of the signal will be averaged and stored in C1.

NOTE: The time constants RC_1 and RC_2 are very long compared to the duration of a half cycle so there is negligible voltage change across C1 or C2 during the half cycles in which they are connected to the signal.

During the other half cycle C2 is connected to the signal source as the switch closes to the right and a square wave of voltage is therefore generated at the filter output.

In Fig. 4-25(b) it is shown that DC signals may also be applied to two points to the filter so that the filter output is the sum of the AC signal and the two DC signals. Operation of the DC sections is similar to the typical chopper circuit in which a DC signal acting through a "lag element" (R_2 or R_3) is translated into a square wave of voltage as it is shorted to common during alternate half cycles.

Fig. 4-25(c) shows the transistor equivalent to the synchronous filter in which the mechanical switches are replaced with transistors operating as switches. In this application it should be noted that the transistor acts as an open switch when the base (in the case of a PNP) is more positive than the collector and that it is a closed switch regardless of collector polarity when adequate negative drive is applied to the base. It follows that NPN transistors will also work as switches when polarities are simply reversed.

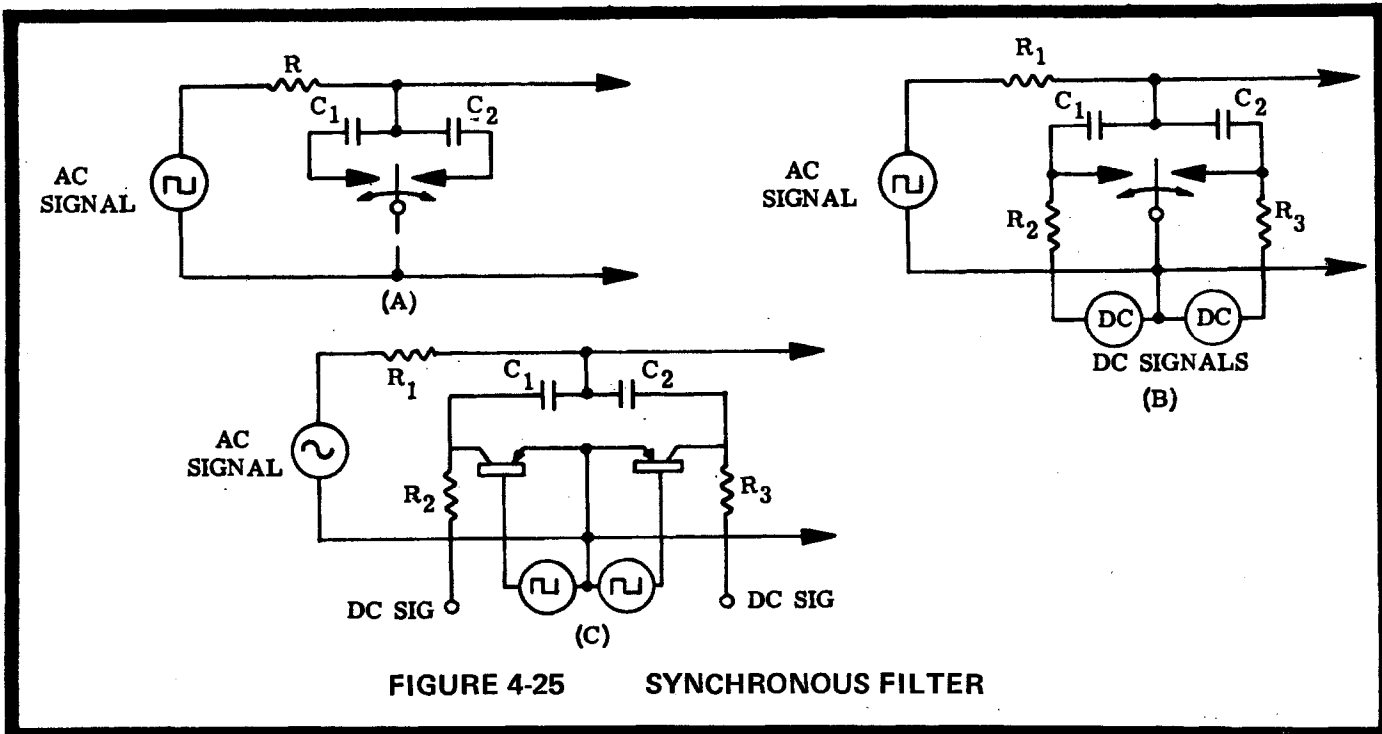

4.11.2 Synchronous Filter as Voltage Limiter - The synchronous filter may also be used as a voltage limiter in such a way that "in" or "out" of phase signals may be limited independently at different amplitude levels. In the lateral guidance channel this is used for separate left and right bank adjustments, however, this use of the filter is suited to many applications. In this application of the filter, limiting action occurs when the off condition of the transistor collector voltage tends to exceed the reverse voltage applied to the base. For the purpose of this discussion, assume the transistor to be PNP, noting that NPN transistors behave the same with all polarities reversed. If the signal is negative during the off half cycle, the transistor switch will not conduct regardless of the magnitude of the signal (not considering exceeding design limits); but if the signal is positive, conduction will occur when the collector becomes more positive than the base. Fig. 4-26 illustrates this by showing the fact that the two junctions (collector-base and emitter-base) of the transistor are actually diodes.

FIGURE 4-26

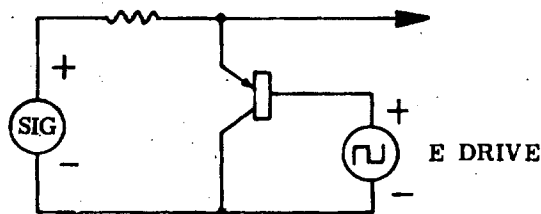

WHEN E SIG. IS MORE POSITIVE THAN E DRIVE, CONDUCTION OCCURS

Fig. 4-27 shows a synchronous filter in which the drive voltages to the two sides may be adjusted independently. Since it has already been noted that PNP transistor will only display limiting action (when functioning as an open switch) when the signal is positive; it follows that one will limit when the signal is of "180°" phase. It will be noted that during the half cycle when the input is positive S_1 is shown to be open and S_2 is closed. The reverse voltage at the collector of S_1 is the sum of voltages stored in the two capacitors (E_C average of usable signal voltage during the half cycle) as would be noted by traversing the closed loop consisting of S_1 , S_2 , C_1 and C_2 . When this voltage is greater than the voltage $[E_d \times R_2 + (R_1 + R_2)]$ which is applied to the base, S_1 conducts and the combined voltages E_{C1} and E_{C2} are thus limited. The level at which this occurs can be adjusted by varying R_1 or R_2 . It follows from this discussion that should the phase of the input signal relative to that of switch excitation be reversed, transistor S_2 will become the limiter.

4.12 PHASE DETECTOR

Fig. 4-28 illustrates the phase detector network used throughout the system (including radio coupler) at points where AC signals are to be translated into DC signals. The symmetry of this network, in which two equal AC square wave voltage generators acting in phase opposition (Push-Pull), provide what is called reference excitation. Each of these generators drives a rectifier circuit consisting of a diode in series with a resistor and capacitor connected in parallel to form an AC eliminating filter. Since the voltages are out of phase (of opposite AC polarity) the rectification action takes place in opposite half cycles. Current will pass only if conduction can take place through the center branch of the network. In the absence of a signal applied to the base of the transistor in the center leg, conduction through the transistor will be determined by the bias resistor (R_B).

NOTE: This branch would be common to both rectifier circuits.

Since the diodes, resistors, and capacitors of the other circuits are respectively identical, the rectified circuit combination should be equal if no signal is present in the center leg to vary the conductivity of the transistor from one half cycle to the next. If a control signal (V_S) is applied to the base of the transistor so that it is negative when generator voltage (E_1) is negative, current

flow through R_{L1} will be greater than that through R_{L2} and the output voltage E_{DC} will be negative when measured from terminal (2) to terminal (1), increasing the amplitude of V_S will increase E_{DC} and reversing the phase or AC polarity will reverse the polarity of E_{DC} .

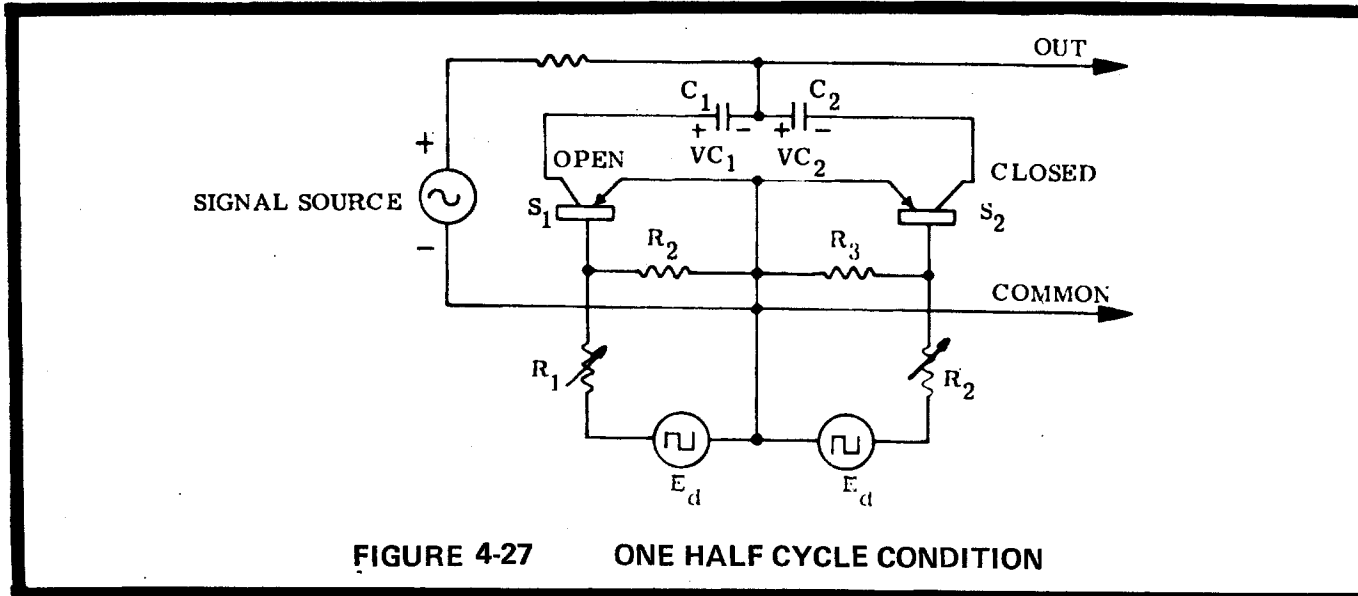

FIGURE 4-27 ONE HALF CYCLE CONDITION

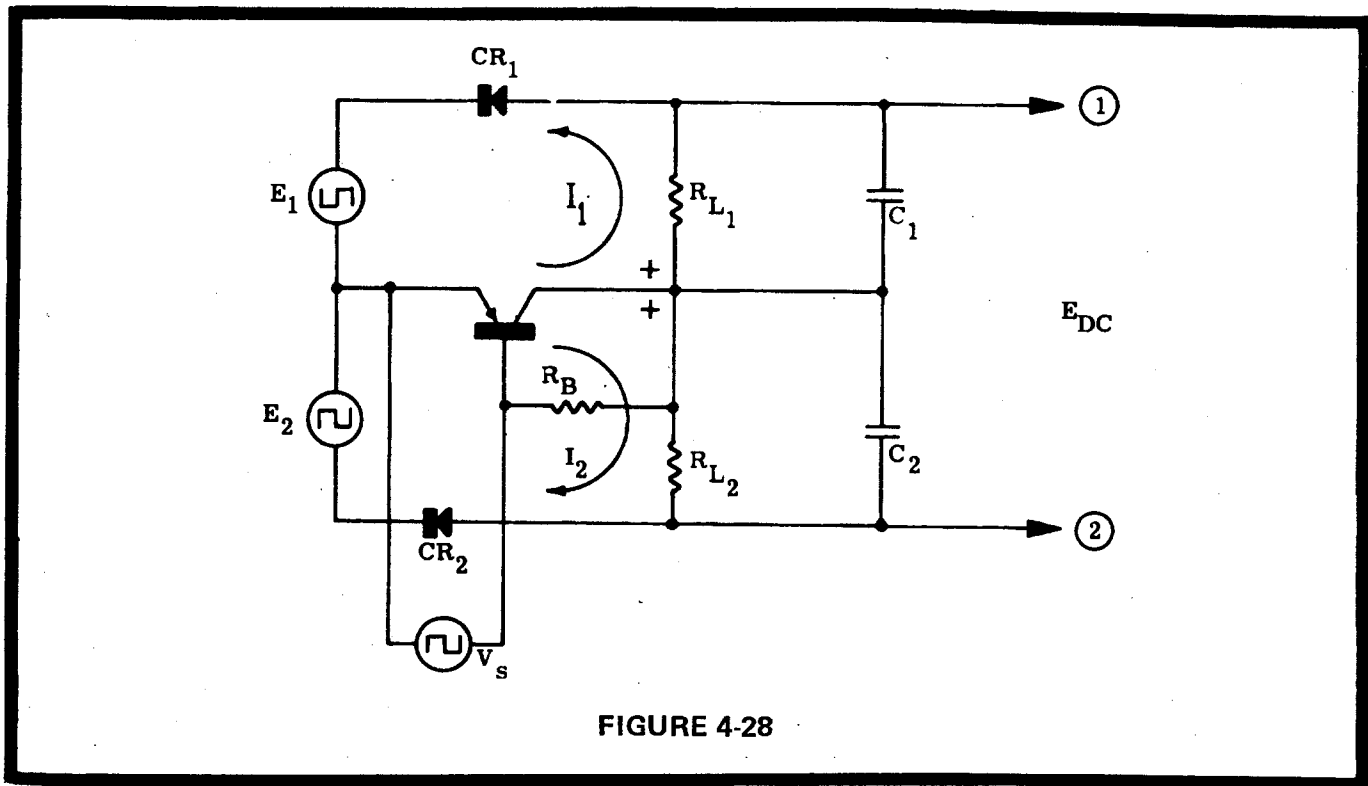
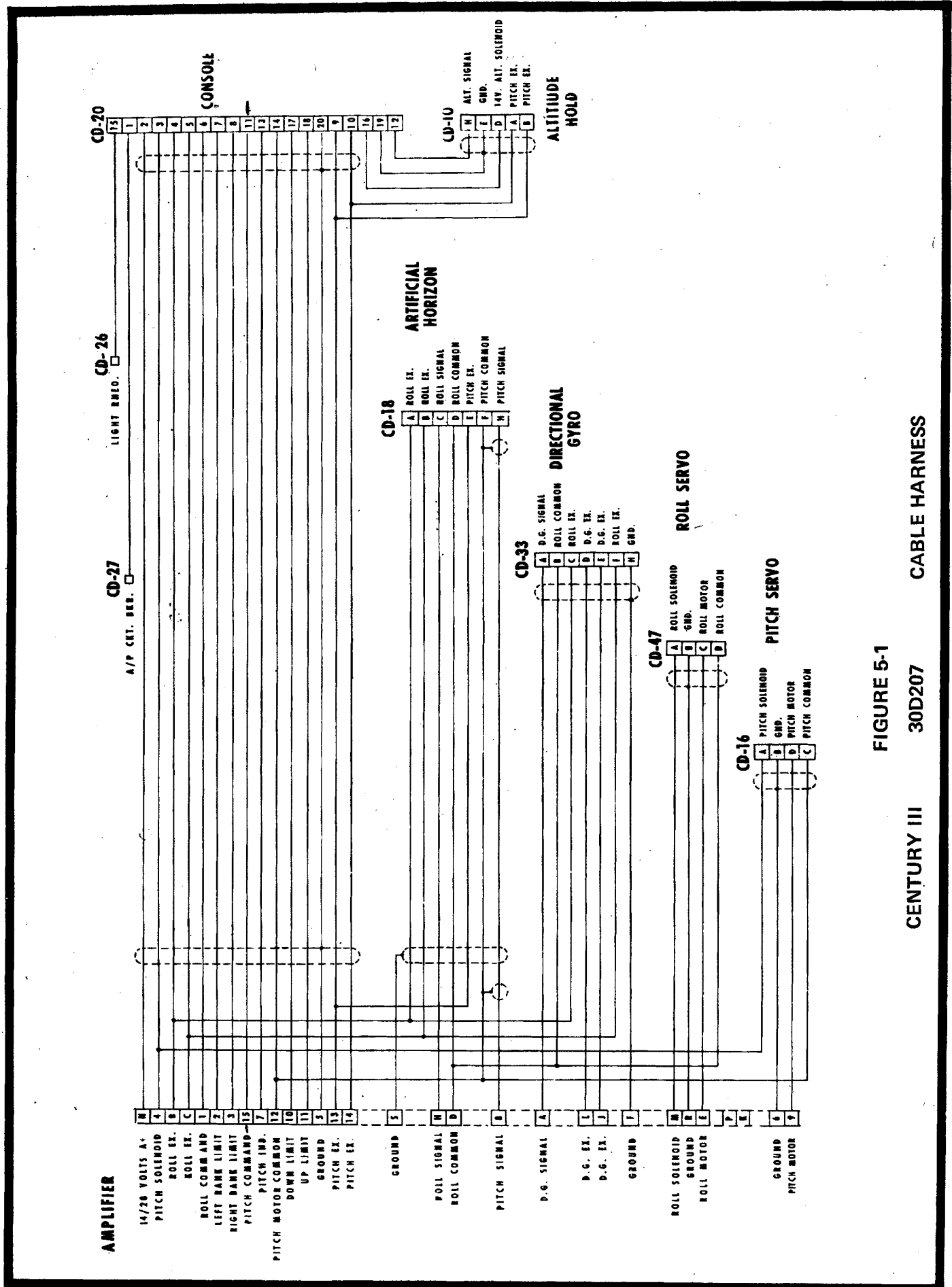

FIGURE 4-28



CENTURY III

30D207

FIGURE 5-1

CABLE HARNESS

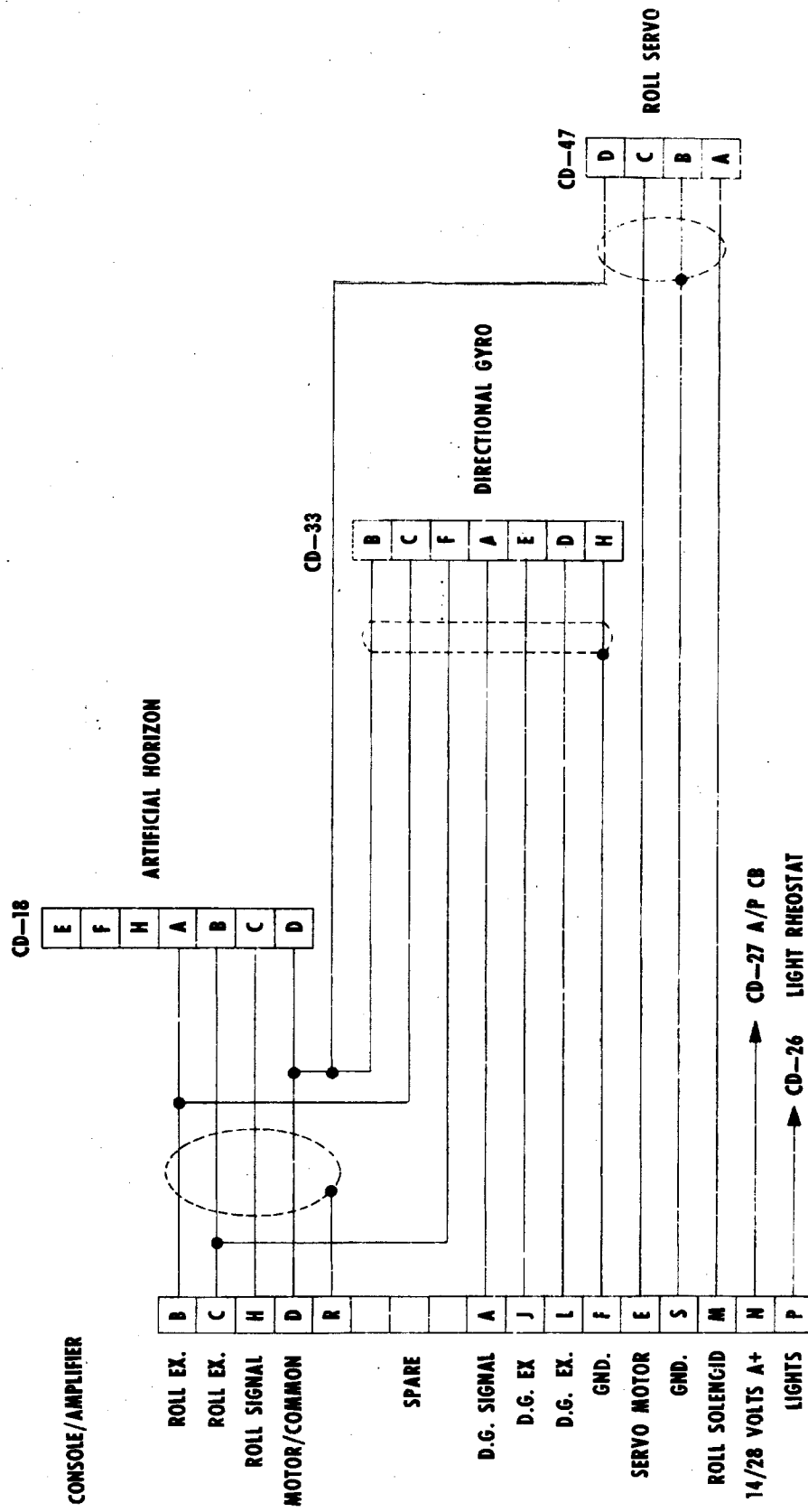

FIGURE 5-2
CENTURY II 30C198 CABLE HARNESS

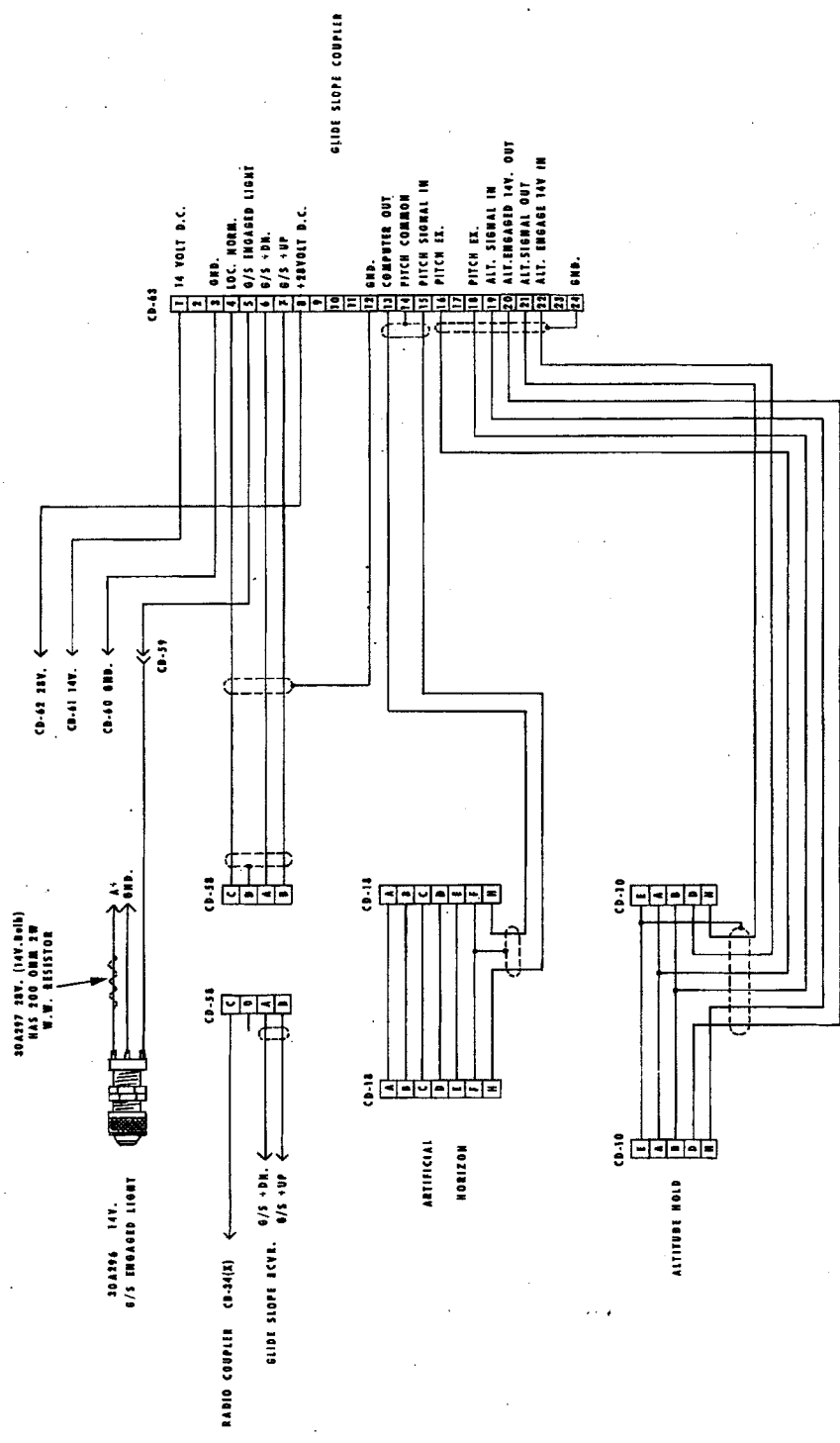
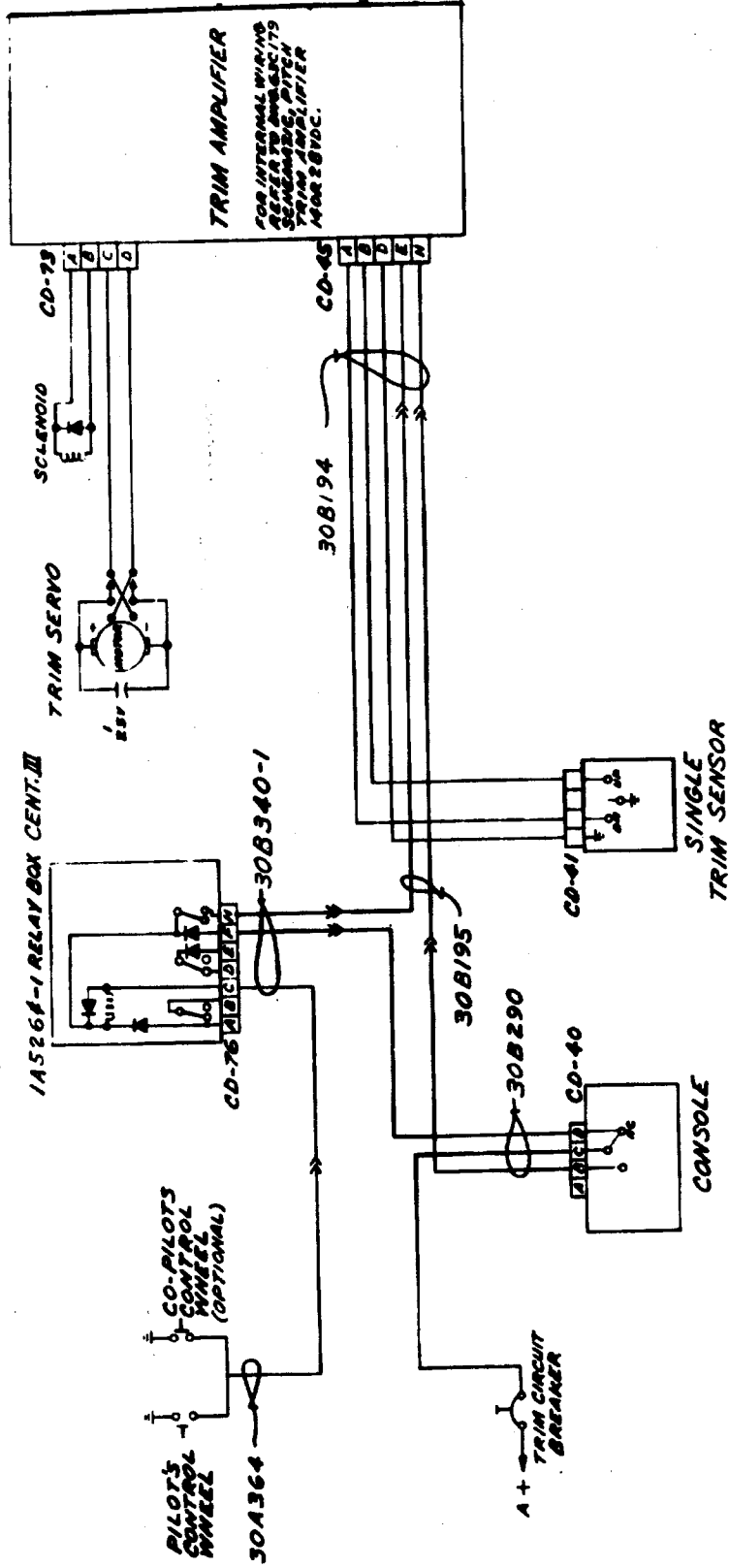
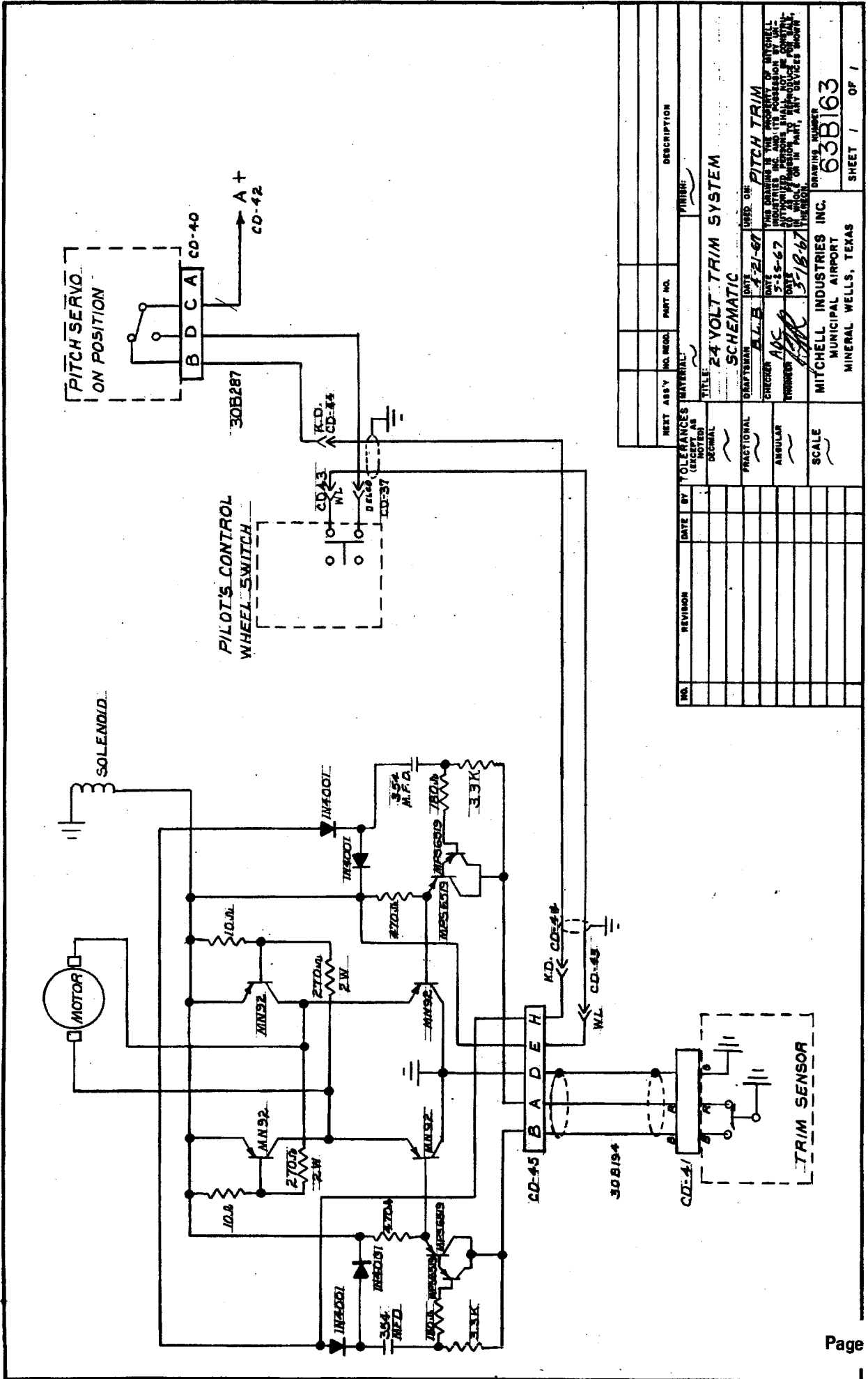

FIGURE 5-3
GLIDE SLOPE COUPLER 30C291 CABLE HARNESS



SCHEMATIC PUSH BUTTON AUTOMATIC TRIM SYSTEM TYPE 1



NO.	REVISION	DATE	BY	TOLERANCES (EXCEPT AS NOTED)	MATERIAL	PART NO.	DESCRIPTION
				FRACTIONAL			
				DECIMAL			
				ANGULAR			
				SCALE			
TITLE: 24 VOLT TRIM SYSTEM SCHEMATIC							
DEPARTMENT: A.L.C.B. DATE: 11-21-67							
ENGINEER: APC DATE: 5-15-67							
TRAINER: [Signature] DATE: 3-18-67							
USED ON: PITCH TRIM							
MITCHELL INDUSTRIES INC. MUNICIPAL AIRPORT MINERAL WELLS, TEXAS							
DRAWING NUMBER: 63B163							
SHEET 1 OF 1							

24 VOLT TRIM SYSTEM SCHEMATIC
TYPE 2

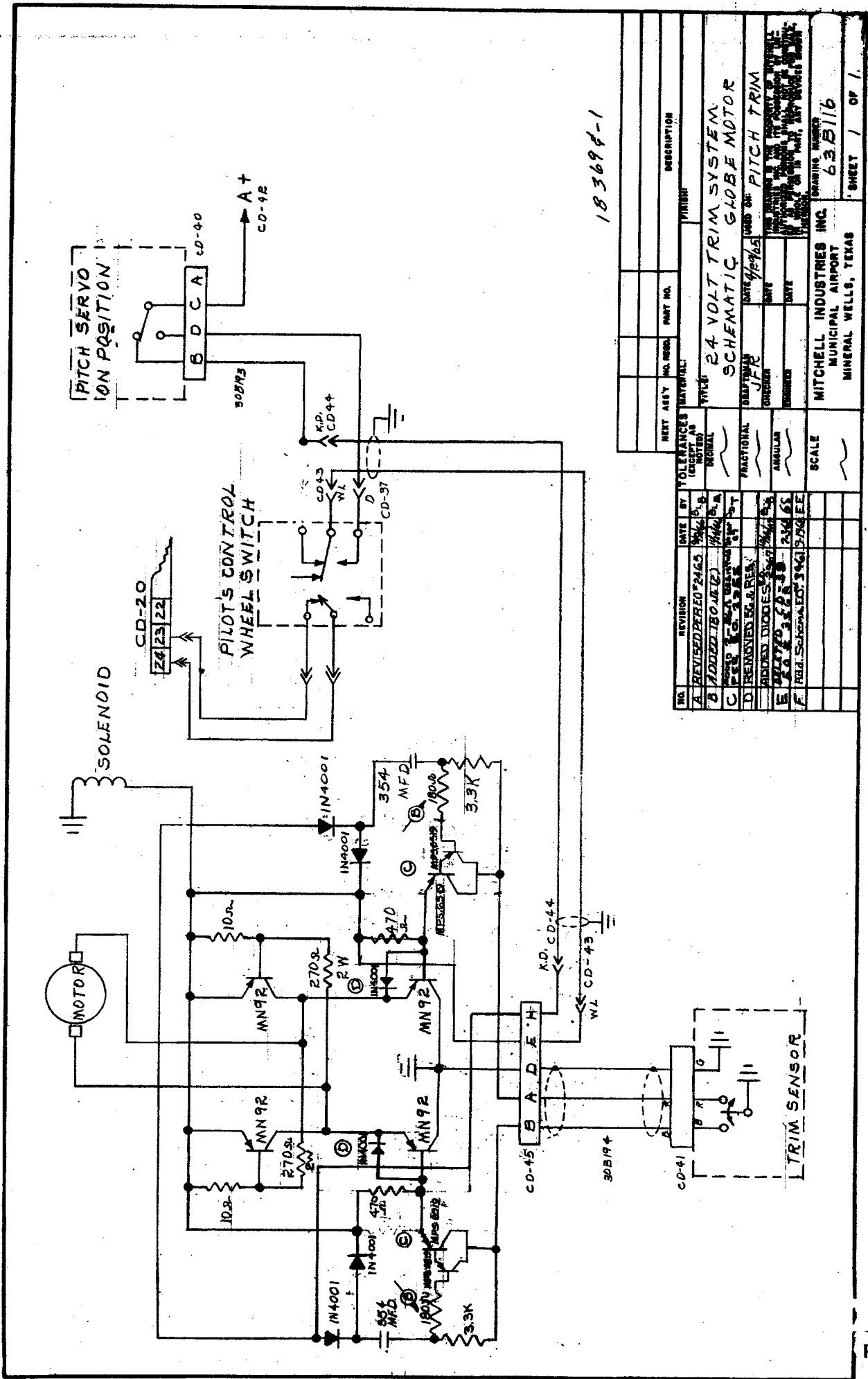

183694-1

REV.	REVISION	DATE	BY	TOLERANCES (EXCEPT AS NOTED)	DESCRIPTION
A	REVISED PER EO 2460	2/24/65	JFK	NORMAL	24 VOLT TRIM SYSTEM SCHEMATIC GLOBE MOTOR
B	ADDED (EO 12812)	2/24/65	JFK	FRACTIONAL	
C	PER EO 12812	2/24/65	JFK	ANGULAR	
D	REMOVED SQUARE	2/24/65	JFK	SCALE	
E	ADDED DIODES	2/24/65	JFK		
F	REL. SCHEMATIC	3/4/65	JFK		

24 VOLT TRIM SYSTEM SCHEMATIC
GLOBE MOTOR TYPE 2a

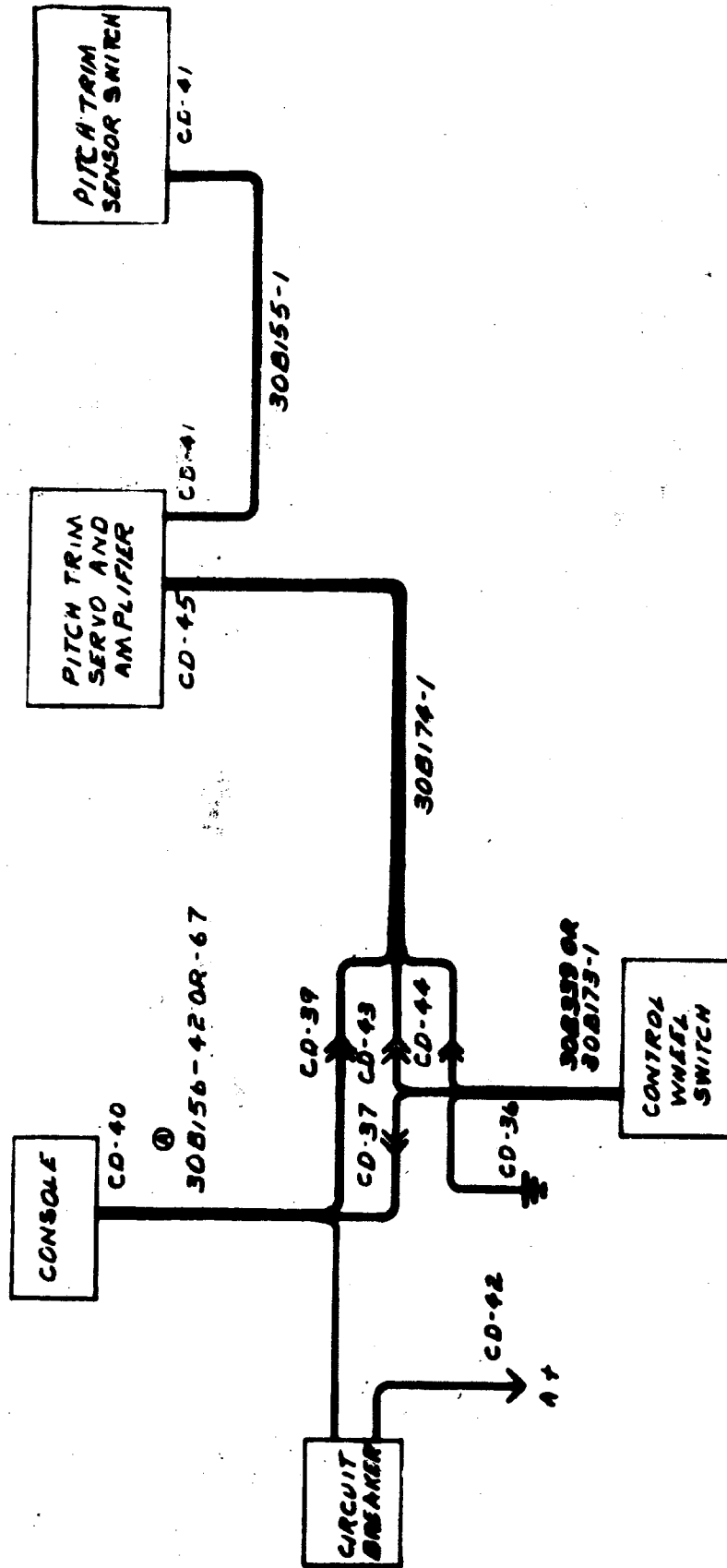

CABLE HOOK-UP PITCH TRIM SYSTEM
FOR ALTIMATIC III TYPE 3

REV	DESCRIPTION	DATE	APPROVED
1	RELEASED PER E.O. 14176	1-28-72	J. MILLER

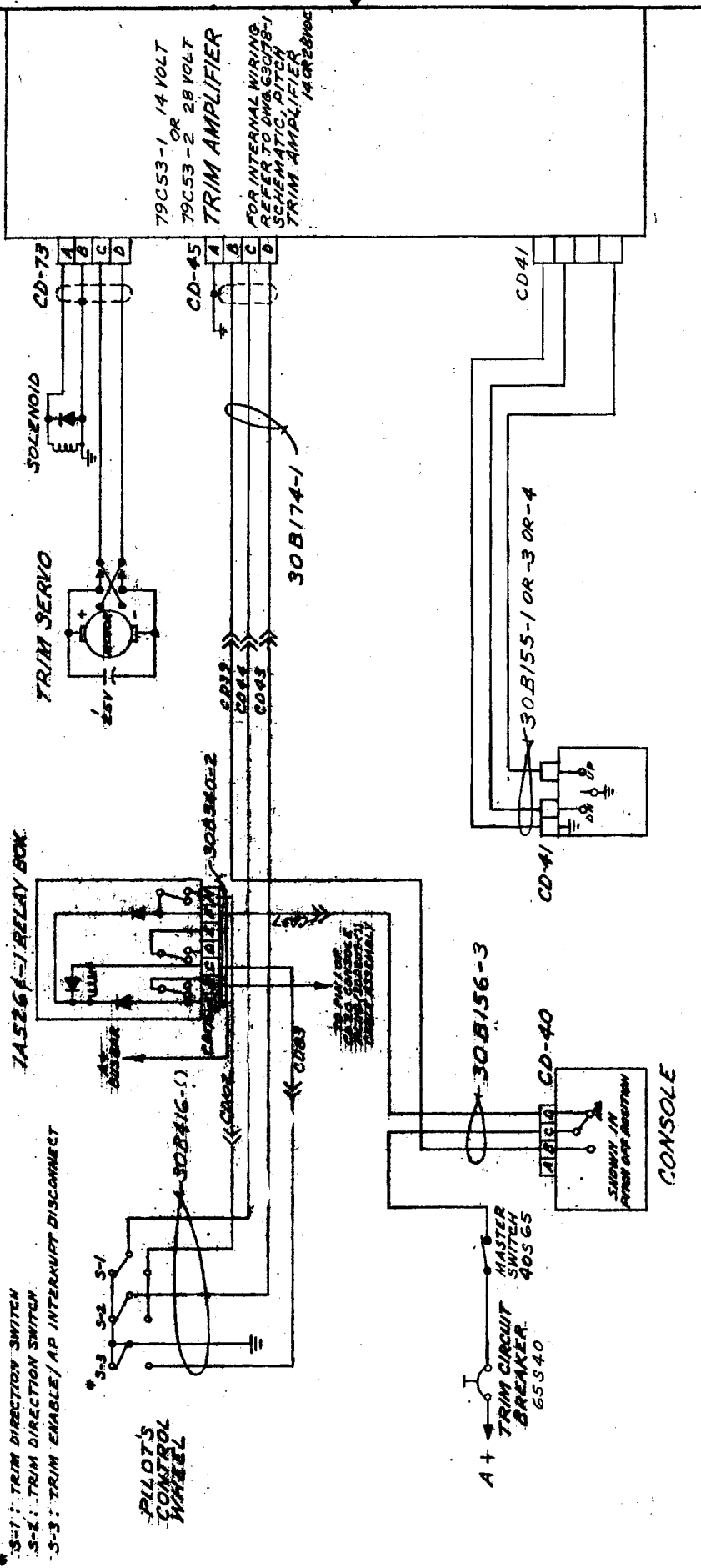

QTY	ITEM PART NUMBER	DESCRIPTION
	30B155-1 OR 3 OR-4	SOLENOID
	CD-41	CONNECTOR PANEL
	CD-40	CONSOLE
	CD-42	CONNECTOR PANEL
	CD-43	CONNECTOR PANEL
	CD-44	CONNECTOR PANEL
	30B174-1	CABLE
	79C53-1 OR 2	TRIM AMPLIFIER

LIST OF MATERIALS
MITCHELL INDUSTRIES, INC. MINERAL WELLS, TEXAS
SCHMATIC COMMAND / AUTOMATIC TRIM SYSTEM TYPE 4a
SIZE: 63 C 2 88
REV: 1887

DATE	BY	APP'D	TITLE
7-14-72	J. Swainson		ENGINEER
7-14-72	E. C. CAME		APPROVED

SCHEMATIC COMMAND/AUTOMATIC TRIM SYSTEM TYPE 4a

1A5264-1 RELAY BOX CENTER

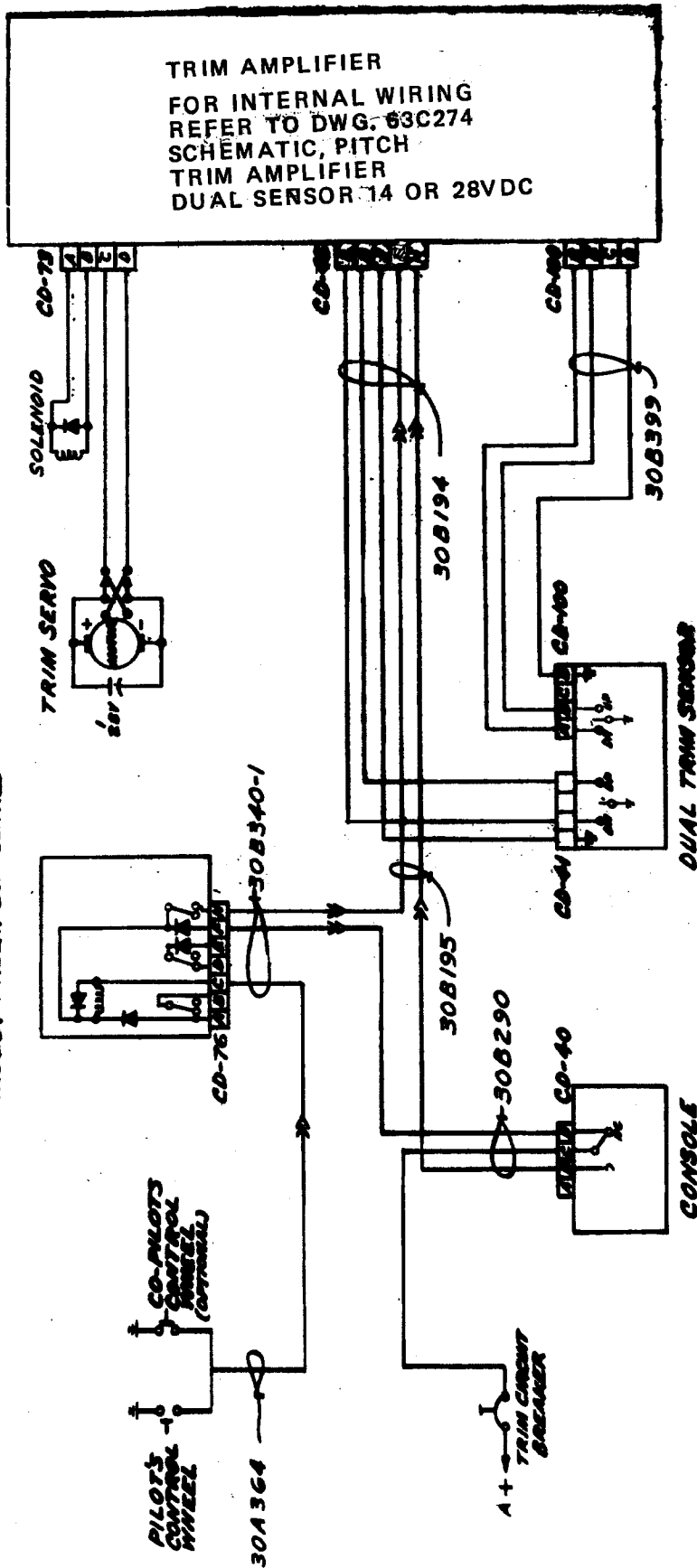

SCHEMATIC PUSH BUTTON AUTOMATIC
TRIM SYSTEM TYPE 5

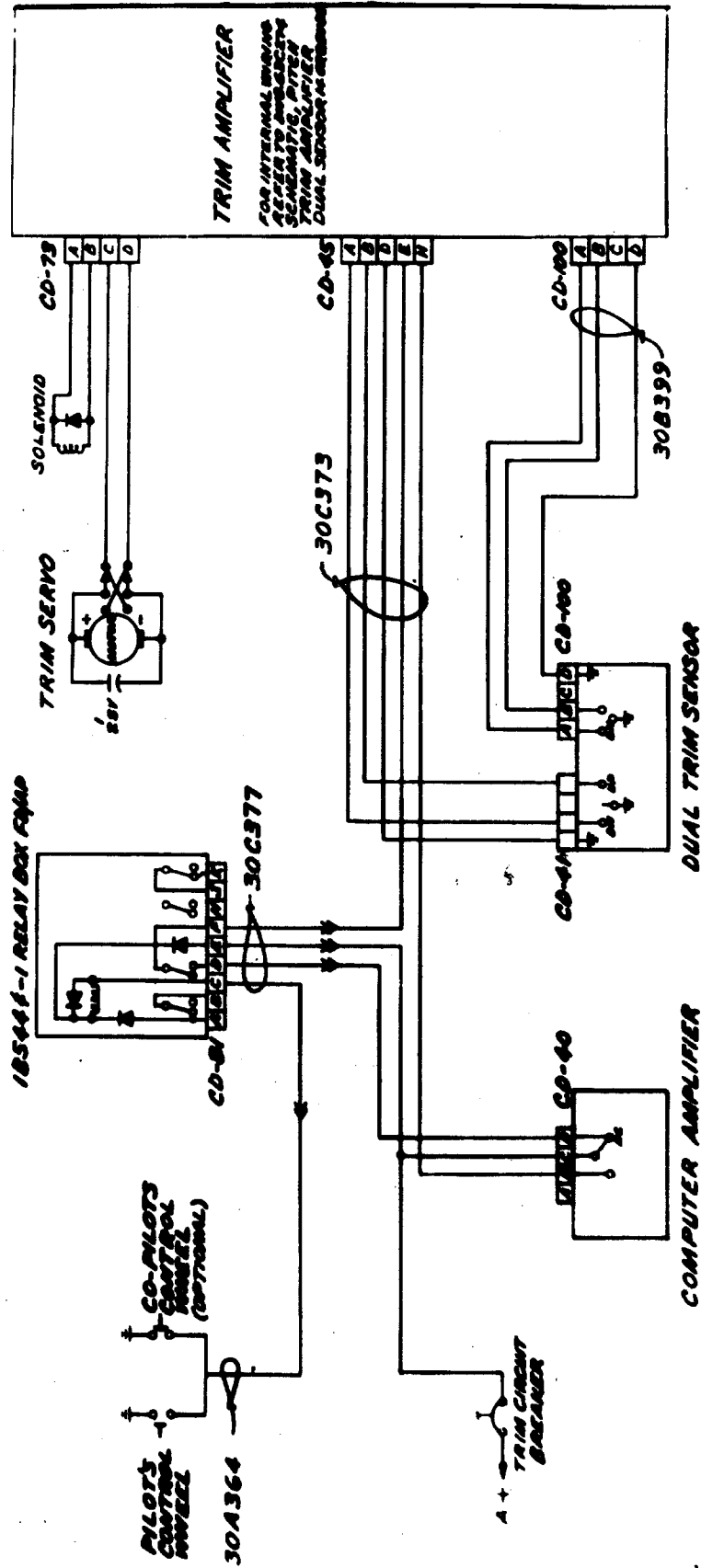

- NOTES:**
1. THIS SYSTEM WIRE IN THE FIELD USING INFORMATION PROVIDED ON DRAWING No. 690E19 AND 690E22.
 2. PRODUCTION CABLING AVAILABLE:
 a. 30C974
 b. 30C973
 c. 30C977
 d. 30B399

SCHEMATIC PUSH BUTTON AUTOMATIC TRIM SYSTEM TYPE 6

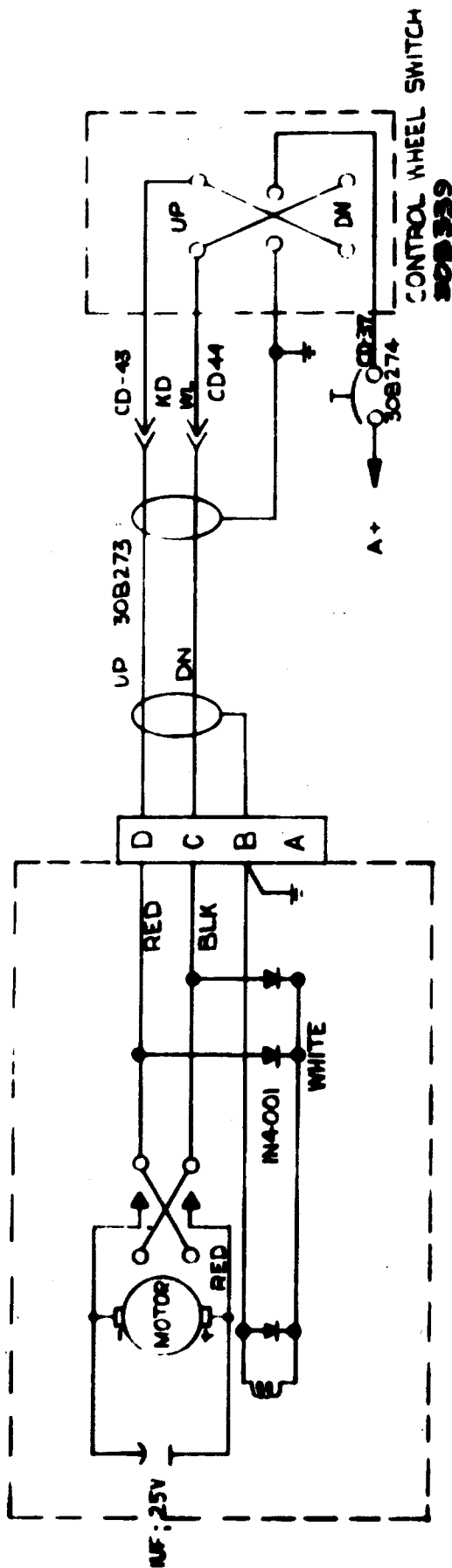

NOTES:

1. FOR SCHEMATIC INFORMATION ON MANUAL COMMAND ELECTRIC TRIM SYSTEMS USING CABLE ASSEMBLY 30B413, REFER TO 63B157-2

WIRING SCHEMATIC FOR MANUAL ELECTRIC
PITCH TRIM SYSTEM (GLOBE) TYPE 7

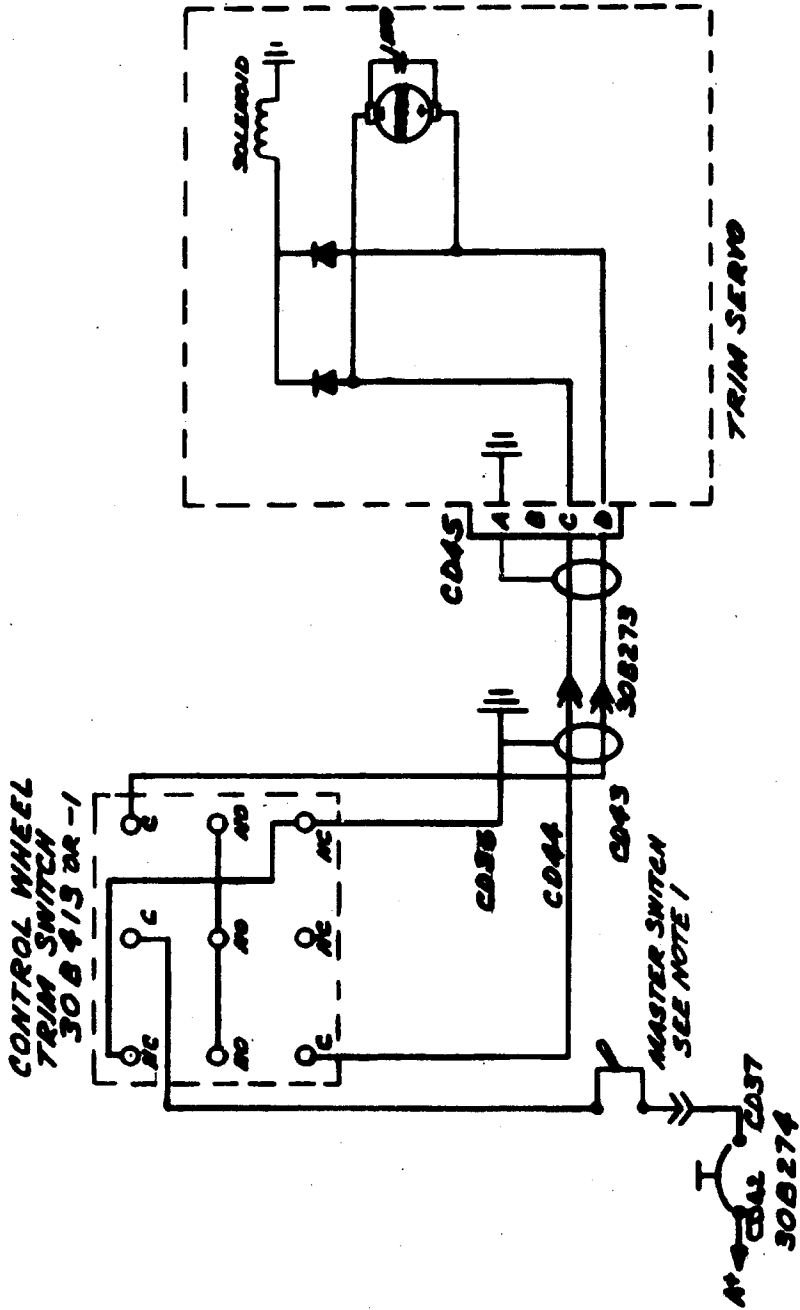

NOTES:
 1. REFER TO INSTALLATION BULLETIN FOR REQUIREMENT OF MASTER SWITCH

WIRING SCHEMATIC FOR MANUAL ELECTRIC PITCH TRIM SYSTEM TYPE 8

REVISIONS		
REV	DESCRIPTION	DATE
1	RELEASED PER E. O. 6204	12-27-71
A	ADD TRIM MASTER SWITCH, INTERMITTENT, I/O 8570	3-23-72

"MICRO-FILM"
FEB 26 1973

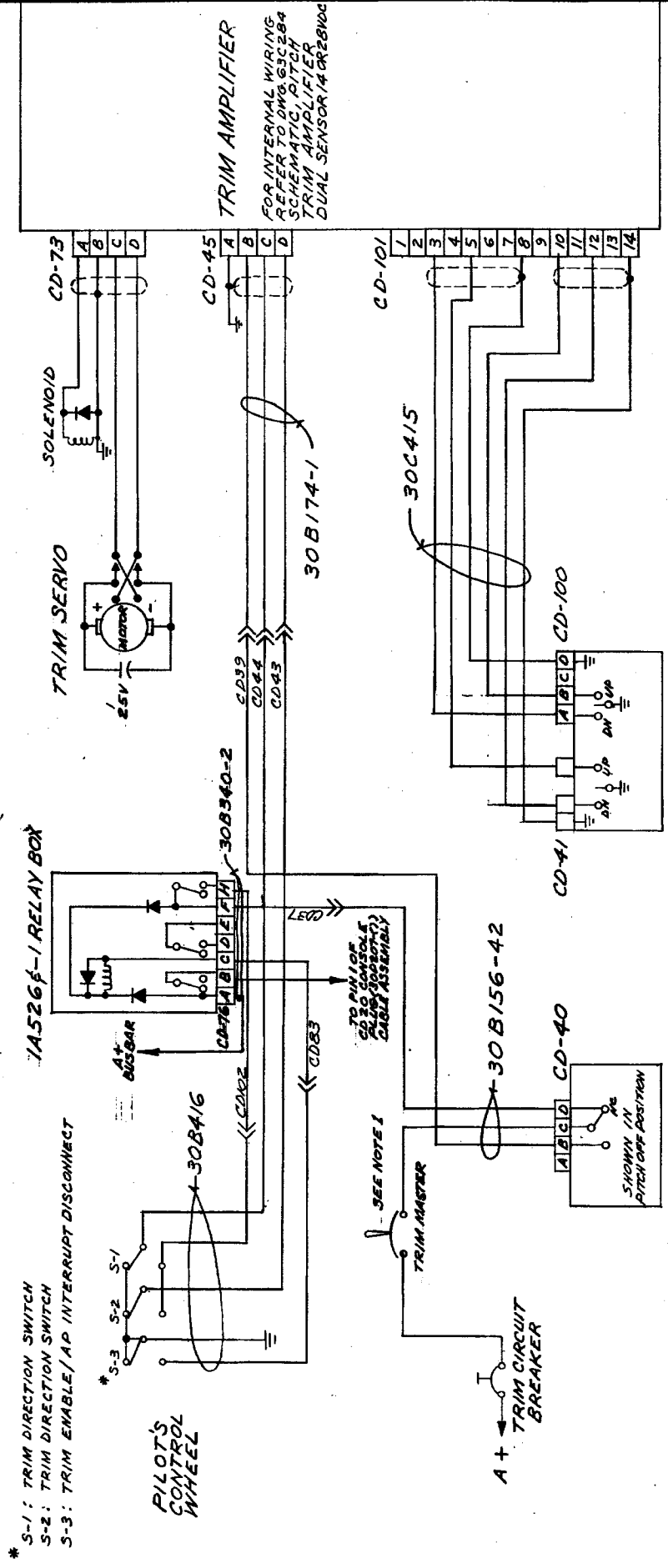

- * S-1: TRIM DIRECTION SWITCH
- S-2: TRIM ENABLE/AP INTERRUPT DISCONNECT
- S-3: TRIM MASTER SWITCH

NOTES:
1. SOME INSTALLATIONS REQUIRE A TRIM MASTER SWITCH. REFER TO THE INSTALLATION BULLETIN FOR APPLICABILITY.

SCHEMATIC COMMAND/AUTOMATIC TRIM SYSTEM TYPE 9

LIST OF MATERIALS	
QTY	ITEM PART NUMBER
1	TRIM SERVO
1	TRIM AMPLIFIER
1	DUAL TRIM SENSOR
1	SOLENOID
1	RELAY BOX
1	CONSOLE
1	TRIM MASTER SWITCH
1	TRIM CIRCUIT BREAKER
1	PILOT'S CONTROL WHEEL
1	WIRE BUNDLE
1	CONNECTORS

DRAWN J. Swinson 4-16-71	ENGINEER E. Cameron 4-18-71	APPROVED J. Mann 4-19-71
CHECKED C. Swift 4-17-71		
TITLE SCHEMATIC COMMAND/AUTOMATIC TRIM SYSTEM (TYPE 9)		
SYN	DWG NO. 63C285	SHEET 1 OF 1

MP 216177

REVISIONS			
LTN	DESCRIPTION	DATE	APPROVED
-	RELEASED PER E.O. 6879	11-21-72	C. WILTON
A	ADDED NOTE 1, E.O. 6980	2-5-73	J.S.
B	ADDED CONTACTS TO SWITCH, E.O. 12866	8-6-73	J.S.

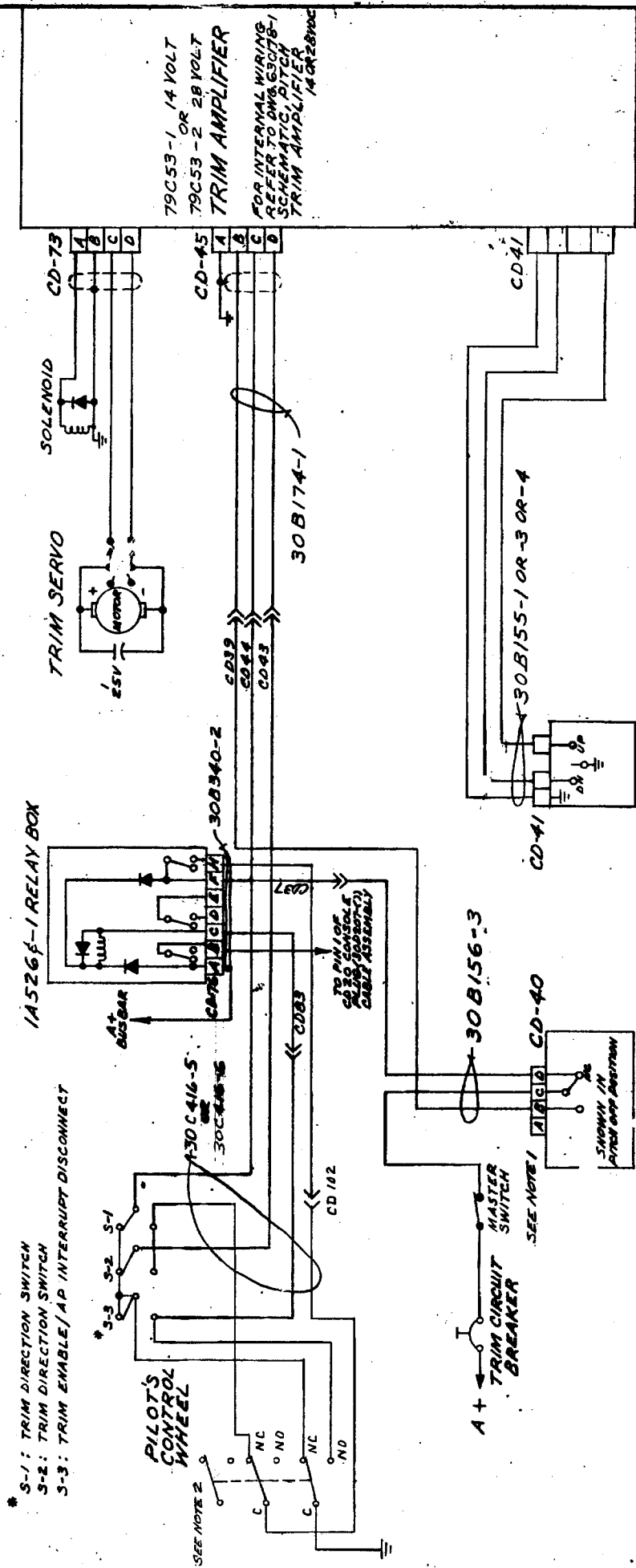

- * S-1: TRIM DIRECTION SWITCH
- S-2: TRIM DIRECTION SWITCH
- S-3: TRIM ENABLE/AP INTERRUPT DISCONNECT

NOTES:

1. SOME INSTALLATIONS DO NOT REQUIRE A TRIM MASTER SWITCH, REFER TO INSTALLATION BULLETIN FOR APPROPRIATE INFORMATION.
2. FOR YAW DAMPER INSTALLATIONS: UTILIZE OPEN (NC) CD-102 CONTACTS FOR SOLENOID AND TO 40S74-1 SWITCH (YD ENGAGE)

C. INSOLE

SCHMATIC COMMAND / AUTOMATIC TRIM SYSTEM TYPE 10

QTY	ITEM	PART NUMBER	DESCRIPTION
	DRAWN	C. WILTON	9-14-72
	CHECKED	FRANKY BOGGETT	8-17-72
	APPROVED	E. CAMERON	9-14-72
	DATE		11/20/72

LIST OF MATERIALS	
MITCHELL INDUSTRIES, INC.	MINERAL WELLS, TEXAS
SCHEMATIC COMMAND / AUTOMATIC TRIM SYSTEM TYPE 10	
630310	

REVISIONS		
LIB	DESCRIPTION	DATE
1	RELEASED PER E.D.F. 6895	5-3-68
		ECULIS

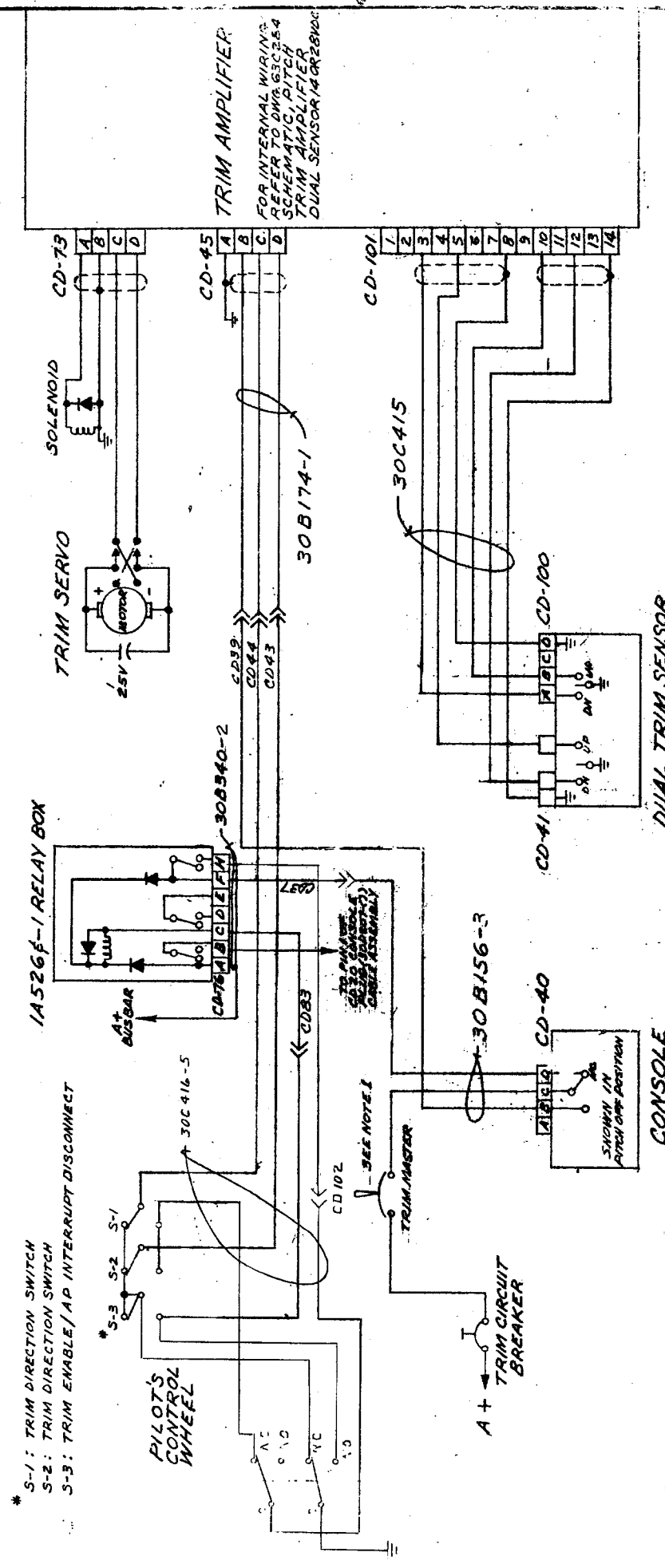

NOTES:
 1. SOME INSTALLATIONS REQUIRE A TRIM MASTER SWITCH. REFER TO THE INSTALLATION BULLETIN FOR APPLICABILITY.

SCHEMATIC COMMAND/AUTOMATIC TRIM SYSTEM TYPE 11

QTY	ITEM PART NUMBER	DESCRIPTION
	8-33-78	MITCHELL INDUSTRIES, INC.
		MINERAL WELLS, TEXAS
		TITLE
		SCHEMATIC
		COMMAND/AUTOMATIC
		TRIM SYSTEM (TYPE 11)
		DWG NO.
		63C 311
		REV
		1 OF 1

APPROVED: J. J. WILSON

DATE: 5-3-68

DESIGNED BY: G. S. HERRICK

PROJECT: J. J. WILSON

DRAWN BY: J. J. WILSON

CHECKED BY: G. S. HERRICK

DATE: 5-3-68

PROJECT: J. J. WILSON

SCALE: AS SHOWN

APPROVED: J. J. WILSON

DATE: 5-3-68

DESIGNED BY: G. S. HERRICK

PROJECT: J. J. WILSON

DRAWN BY: J. J. WILSON

CHECKED BY: G. S. HERRICK

DATE: 5-3-68

PROJECT: J. J. WILSON

SCALE: AS SHOWN

**SWITCH & CABLE ASSEMBLY
30B419-3**

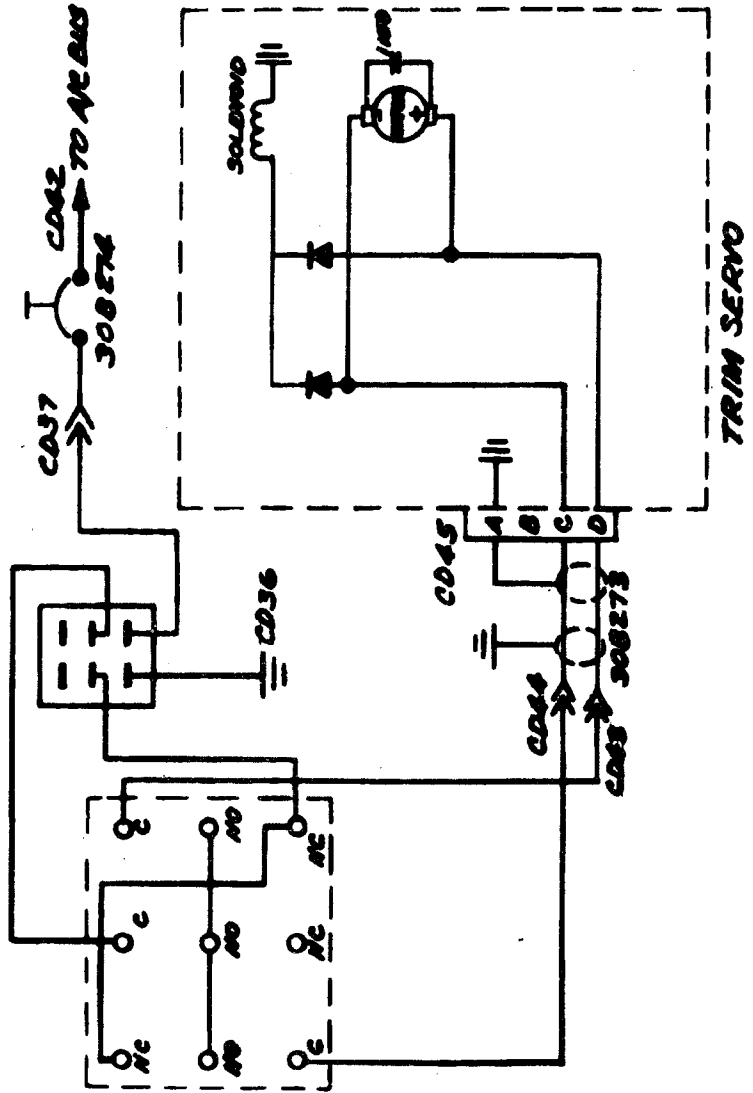

**WIRING SCHEMATIC FOR COMMAND
TRIM SYSTEM TYPE 12**

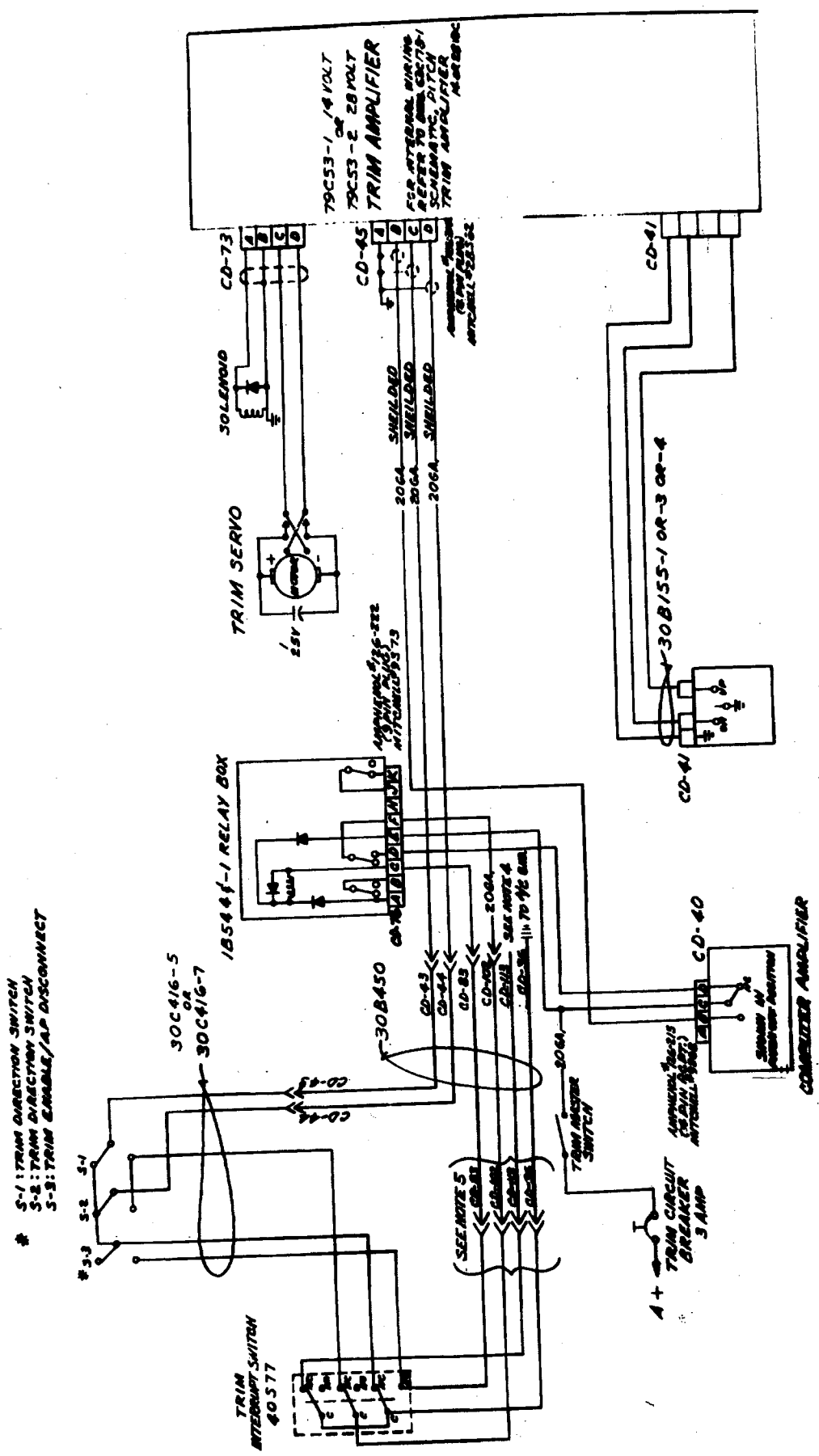

* S-1: TRIM DIRECTION SWITCH
 S-2: TRIM DIRECTION SWITCH
 S-3: TRIM ENABLE/AP DISCONNECT

- NOTES:
1. ALL WIRES TO BE MIL-W-5086A, 22 GA. MIN. UNLESS OTHERWISE NOTED.
 2. CABLE ASSEMBLIES 30B416-5 & 30C415 ARE SUPPLIED WITH AUTOPILOT KIT.
 3. EDO-AIRE MITCHELL TRIM SYSTEMS USING THE 30B416 SWITCH & CABLE ASSEMBLY IS APPROVED AS A FAIL SAFE SYSTEM & ANY CHANGE TO THE SYSTEM MUST BE APPROVED BY THE F.A.A.
 4. FOR YAW DAMPER INSTALLATIONS: UTILIZE OPEN (NC) CONTACTS FOR SOLENOID A+ TO 40S74-1 SWITCH (Y/D ENGAGE).

SCHEMATIC COMMAND/AUTOMATIC TRIM SYSTEM TYPE 14

REV.	DESCRIPTION	DATE	APPROVED
1	ISSUED PER E.O. 7657	1-14-74	B.L.B.
2	ADDED NOTE 8 (30416-5) AND 139	1-19-74	
3	ADD. 22 30416-5, 30416-6 AND 139	5-16-74	

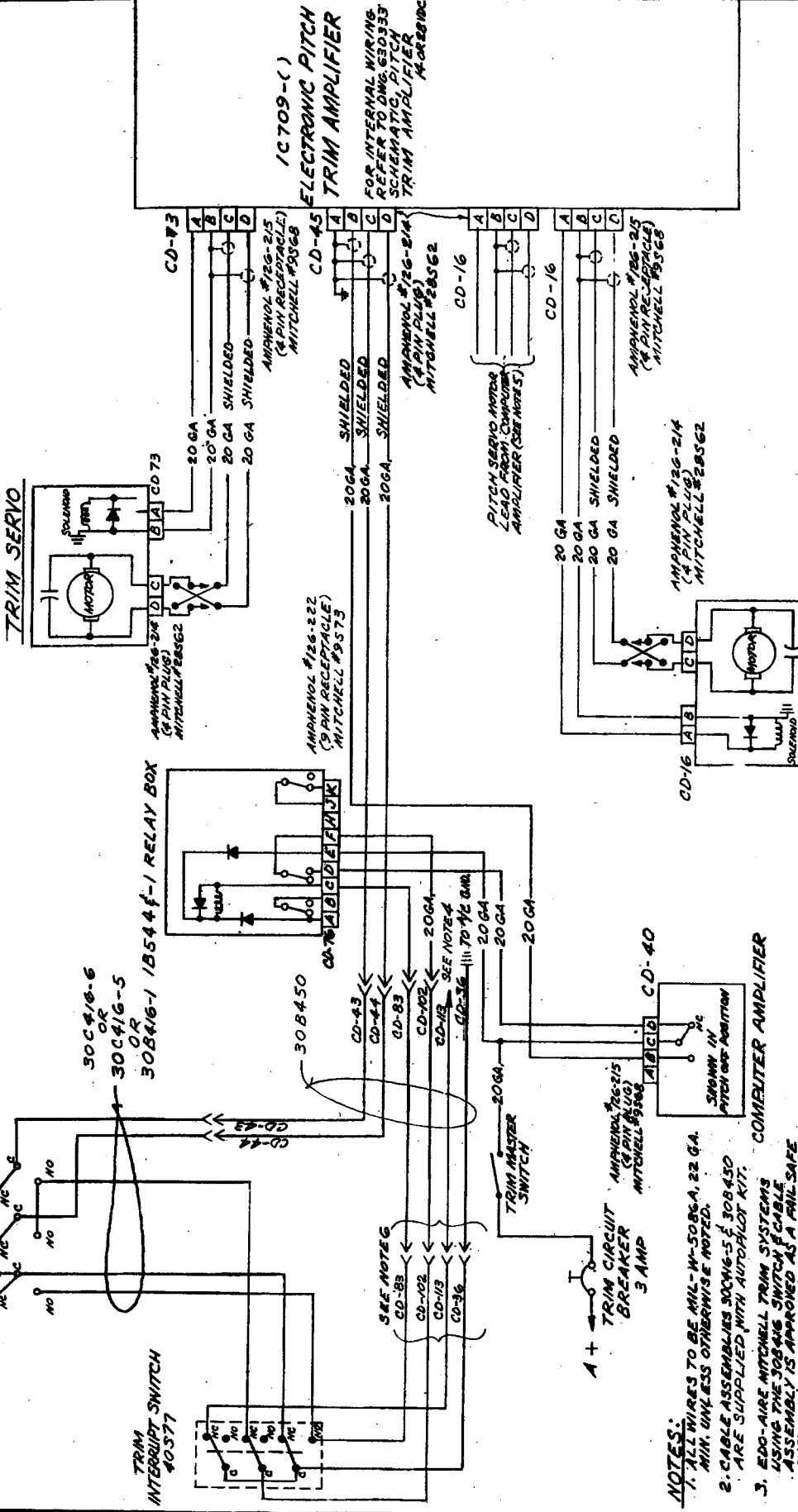

QTY	ITEM PART NUMBER	DESCRIPTION
1	308450	TRIM SERVO MOTOR (4 PIN PLUG) MITCHELL #9562
1	1B544-1	RELAY BOX
1	40577	TRIM SWITCH
1	30416-5	CABLE ASSEMBLY (4 PIN PLUG) MITCHELL #9562
1	30416-6	CABLE ASSEMBLY (4 PIN PLUG) MITCHELL #9562
1	308450	TRIM SERVO MOTOR (4 PIN PLUG) MITCHELL #9562
1	40577	TRIM SWITCH
1	30416-5	CABLE ASSEMBLY (4 PIN PLUG) MITCHELL #9562
1	30416-6	CABLE ASSEMBLY (4 PIN PLUG) MITCHELL #9562

REVISIONS		DATE	APPROVED
1	ISSUED PER E.O. 7657	1-14-74	B.L.B.
2	ADDED NOTE 8 (30416-5) AND 139	1-19-74	
3	ADD. 22 30416-5, 30416-6 AND 139	5-16-74	

LIST OF MATERIALS		DESCRIPTION
1	308450	TRIM SERVO MOTOR (4 PIN PLUG) MITCHELL #9562
1	1B544-1	RELAY BOX
1	40577	TRIM SWITCH
1	30416-5	CABLE ASSEMBLY (4 PIN PLUG) MITCHELL #9562
1	30416-6	CABLE ASSEMBLY (4 PIN PLUG) MITCHELL #9562
1	308450	TRIM SERVO MOTOR (4 PIN PLUG) MITCHELL #9562
1	40577	TRIM SWITCH
1	30416-5	CABLE ASSEMBLY (4 PIN PLUG) MITCHELL #9562
1	30416-6	CABLE ASSEMBLY (4 PIN PLUG) MITCHELL #9562

QTY	ITEM	PART NUMBER	DESCRIPTION
1	308450	TRIM SERVO MOTOR (4 PIN PLUG) MITCHELL #9562	
1	1B544-1	RELAY BOX	
1	40577	TRIM SWITCH	
1	30416-5	CABLE ASSEMBLY (4 PIN PLUG) MITCHELL #9562	
1	30416-6	CABLE ASSEMBLY (4 PIN PLUG) MITCHELL #9562	
1	308450	TRIM SERVO MOTOR (4 PIN PLUG) MITCHELL #9562	
1	40577	TRIM SWITCH	
1	30416-5	CABLE ASSEMBLY (4 PIN PLUG) MITCHELL #9562	
1	30416-6	CABLE ASSEMBLY (4 PIN PLUG) MITCHELL #9562	

1C709-(1)
ELECTRONIC PITCH TRIM AMPLIFIER

FOR INTERNAL WIRING REFER TO DWG. 630333 Schematic of Pitch Trim Amplifier N-022202

MITCHELL INDUSTRIES, INC.
MINERAL WELLS, TEXAS

SCHEMATIC COMMAND/AUTOMATIC TRIM SYSTEM (TYPE 15)

DWG. NO. 63C324

DATE: 1-14-74

DESIGNED BY: SWANSON, J. L.

CHECKED BY: BARRETT, J. H.

ENGINEER: BARRETT, J. H.

APPROVED: SWANSON, J. L.

DATE: 1-14-74

MATERIAL: ALUMINUM

FINISH: ANODIZED

APPLICATION: TRIM SYSTEM

- NOTES:**
1. ALL WIRES TO BE MIL-W-5086, A, 22 GA. MIN. UNLESS OTHERWISE NOTED.
 2. CABLE ASSEMBLIES 30416-5 & 30416-6 ARE SUPPLIED WITH AUTOLLOY KIT.
 3. 30416-5 MITCHELL TRIM SYSTEMS USING THE 308450 SWITCHABLE CABLE ASSEMBLY IS APPROVED AS A SAFE SYSTEM. ANY CHANGE TO THE SYSTEM MUST BE APPROVED BY THE R.A.A.
 4. FOR VAN DAMPER INSTALLATIONS, UTILIZE AN UNUSED SET OF NORMALLY CLOSED CONTACTS ON THE 40577 SWITCH FOR SOLENOID AT TO 40574-2 SWITCH (V.D. ENGAGE). REFER TO VAN DAMPER INSTALLATION INFORMATION.
 5. THIS 4 PIN CONNECTION AND ASSOCIATED WIRING IS PART OF THE CENTURY II AUTO DET. CABLE AND IS SHOWN ON WIRING INTERCONNECT DRAWING NO. 63C314.
 6. THESE CONNECTIONS EXIST ONLY WHEN SWITCHABLE CABLE ASSEMBLY 30416-5 OR 30416-6 IS USED. WHEN 308450-1 IS USED, THESE CONNECTIONS WILL NOT BE PRESENT. WHEN USING 308450, THESE CONNECTIONS WILL NOT BE PRESENT. WHEN USING 308450, THESE CONNECTIONS WILL NOT BE PRESENT. WHEN USING 308450, THESE CONNECTIONS WILL NOT BE PRESENT.

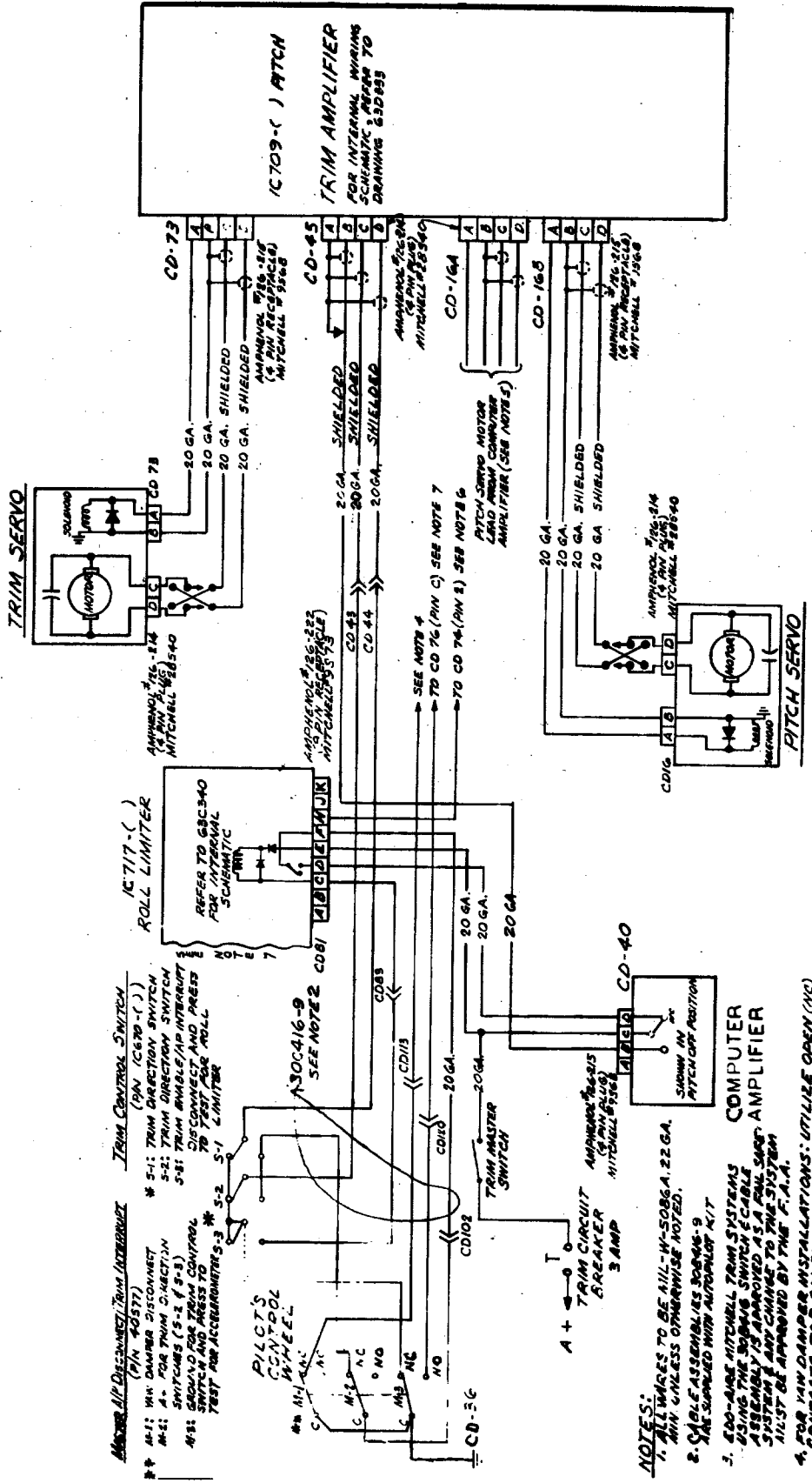

Master All Disconnect/Trim Interrupt (PIN 4087)
 TRIM CONTROL SWITCH (PIN 1630-C)
 * S-1: TRIM DIRECTION SWITCH
 * S-2: TRIM DIRECTION SWITCH
 * S-3: TRIM ENABLE/INTEGRITY DISCONNECT AND PRESS TO TEST FOR ROLL
 * S-4: TRIM DIRECTION SWITCH
 * S-5: TRIM DIRECTION SWITCH
 * S-6: TRIM DIRECTION SWITCH
 * S-7: TRIM DIRECTION SWITCH
 * S-8: TRIM DIRECTION SWITCH
 * S-9: TRIM DIRECTION SWITCH
 * S-10: TRIM DIRECTION SWITCH
 * S-11: TRIM DIRECTION SWITCH
 * S-12: TRIM DIRECTION SWITCH
 * S-13: TRIM DIRECTION SWITCH
 * S-14: TRIM DIRECTION SWITCH
 * S-15: TRIM DIRECTION SWITCH
 * S-16: TRIM DIRECTION SWITCH
 * S-17: TRIM DIRECTION SWITCH
 * S-18: TRIM DIRECTION SWITCH
 * S-19: TRIM DIRECTION SWITCH
 * S-20: TRIM DIRECTION SWITCH
 * S-21: TRIM DIRECTION SWITCH
 * S-22: TRIM DIRECTION SWITCH
 * S-23: TRIM DIRECTION SWITCH
 * S-24: TRIM DIRECTION SWITCH
 * S-25: TRIM DIRECTION SWITCH
 * S-26: TRIM DIRECTION SWITCH
 * S-27: TRIM DIRECTION SWITCH
 * S-28: TRIM DIRECTION SWITCH
 * S-29: TRIM DIRECTION SWITCH
 * S-30: TRIM DIRECTION SWITCH
 * S-31: TRIM DIRECTION SWITCH
 * S-32: TRIM DIRECTION SWITCH
 * S-33: TRIM DIRECTION SWITCH
 * S-34: TRIM DIRECTION SWITCH
 * S-35: TRIM DIRECTION SWITCH
 * S-36: TRIM DIRECTION SWITCH
 * S-37: TRIM DIRECTION SWITCH
 * S-38: TRIM DIRECTION SWITCH
 * S-39: TRIM DIRECTION SWITCH
 * S-40: TRIM DIRECTION SWITCH
 * S-41: TRIM DIRECTION SWITCH
 * S-42: TRIM DIRECTION SWITCH
 * S-43: TRIM DIRECTION SWITCH
 * S-44: TRIM DIRECTION SWITCH
 * S-45: TRIM DIRECTION SWITCH
 * S-46: TRIM DIRECTION SWITCH
 * S-47: TRIM DIRECTION SWITCH
 * S-48: TRIM DIRECTION SWITCH
 * S-49: TRIM DIRECTION SWITCH
 * S-50: TRIM DIRECTION SWITCH
 * S-51: TRIM DIRECTION SWITCH
 * S-52: TRIM DIRECTION SWITCH
 * S-53: TRIM DIRECTION SWITCH
 * S-54: TRIM DIRECTION SWITCH
 * S-55: TRIM DIRECTION SWITCH
 * S-56: TRIM DIRECTION SWITCH
 * S-57: TRIM DIRECTION SWITCH
 * S-58: TRIM DIRECTION SWITCH
 * S-59: TRIM DIRECTION SWITCH
 * S-60: TRIM DIRECTION SWITCH
 * S-61: TRIM DIRECTION SWITCH
 * S-62: TRIM DIRECTION SWITCH
 * S-63: TRIM DIRECTION SWITCH
 * S-64: TRIM DIRECTION SWITCH
 * S-65: TRIM DIRECTION SWITCH
 * S-66: TRIM DIRECTION SWITCH
 * S-67: TRIM DIRECTION SWITCH
 * S-68: TRIM DIRECTION SWITCH
 * S-69: TRIM DIRECTION SWITCH
 * S-70: TRIM DIRECTION SWITCH
 * S-71: TRIM DIRECTION SWITCH
 * S-72: TRIM DIRECTION SWITCH
 * S-73: TRIM DIRECTION SWITCH
 * S-74: TRIM DIRECTION SWITCH
 * S-75: TRIM DIRECTION SWITCH
 * S-76: TRIM DIRECTION SWITCH
 * S-77: TRIM DIRECTION SWITCH
 * S-78: TRIM DIRECTION SWITCH
 * S-79: TRIM DIRECTION SWITCH
 * S-80: TRIM DIRECTION SWITCH
 * S-81: TRIM DIRECTION SWITCH
 * S-82: TRIM DIRECTION SWITCH
 * S-83: TRIM DIRECTION SWITCH
 * S-84: TRIM DIRECTION SWITCH
 * S-85: TRIM DIRECTION SWITCH
 * S-86: TRIM DIRECTION SWITCH
 * S-87: TRIM DIRECTION SWITCH
 * S-88: TRIM DIRECTION SWITCH
 * S-89: TRIM DIRECTION SWITCH
 * S-90: TRIM DIRECTION SWITCH
 * S-91: TRIM DIRECTION SWITCH
 * S-92: TRIM DIRECTION SWITCH
 * S-93: TRIM DIRECTION SWITCH
 * S-94: TRIM DIRECTION SWITCH
 * S-95: TRIM DIRECTION SWITCH
 * S-96: TRIM DIRECTION SWITCH
 * S-97: TRIM DIRECTION SWITCH
 * S-98: TRIM DIRECTION SWITCH
 * S-99: TRIM DIRECTION SWITCH
 * S-100: TRIM DIRECTION SWITCH

NOTES:
 1. ALL WIRAGES TO BE AIL-W-5086A. 22 GA. AND UNLESS OTHERWISE NOTED.
 2. CABLE ASSEMBLIES BORMAN 9 ARE SUPPLIED WITH AIRFOUR KIT.
 3. 600-AMC MITCHELL TRIM SYSTEMS USING THE SWITCH SWITCH ASSEMBLY IS APPROVED AS A FULL SAMP. SYSTEM & ANY CHANGE TO THE SYSTEM MUST BE APPROVED BY THE F.A.A.
 4. FOR VAN DAMPER INSTALLATIONS: UTILIZE OPEN (NO) CONTACTS FOR SOLENOID A-TO 405-T-1 SWITCH (770-0840). WIRE TO VAN DAMPER INSTALLATION IN PARALLEL WITH THE TRIM SYSTEM AND ASSOCIATED WIRINGS AS PART OF THE TRIM SYSTEM. CONTACTS MUST BE CABLED AND SHOWN ON WIRING DRAWINGS TO SHOWING SERIAL LOCATION.
 5. FOR CONTACTS 22 SERIAL WIRING INFORMATION TO THE 1637R (300-1), (405-T-1), (405-T-2), (405-T-3) LOCATION REFER TO DRAWING 65086-1).

SCHEMATIC COMMAND/AUTOMATIC ELECTRONIC TRIM SYSTEM CENTURY IV TYPE 16

REVISIONS			
REV	DESCRIPTION	DATE	APPROVED
1	RELEASED PER E.O. 12812	12-18-73	ACE
2	REVISIONS TO THE PITCH TRIM SYSTEM	1-10-74	ACE
3	ADDED NOTES 1, 2, 3, 4, 5, 6, 7, 8, 9, 10, 11, 12, 13, 14, 15, 16, 17, 18, 19, 20, 21, 22, 23, 24, 25, 26, 27, 28, 29, 30, 31, 32, 33, 34, 35, 36, 37, 38, 39, 40, 41, 42, 43, 44, 45, 46, 47, 48, 49, 50, 51, 52, 53, 54, 55, 56, 57, 58, 59, 60, 61, 62, 63, 64, 65, 66, 67, 68, 69, 70, 71, 72, 73, 74, 75, 76, 77, 78, 79, 80, 81, 82, 83, 84, 85, 86, 87, 88, 89, 90, 91, 92, 93, 94, 95, 96, 97, 98, 99, 100	1-30-74	ACE
4	ADDED NOTE 1, 2, 3, 4, 5, 6, 7, 8, 9, 10, 11, 12, 13, 14, 15, 16, 17, 18, 19, 20, 21, 22, 23, 24, 25, 26, 27, 28, 29, 30, 31, 32, 33, 34, 35, 36, 37, 38, 39, 40, 41, 42, 43, 44, 45, 46, 47, 48, 49, 50, 51, 52, 53, 54, 55, 56, 57, 58, 59, 60, 61, 62, 63, 64, 65, 66, 67, 68, 69, 70, 71, 72, 73, 74, 75, 76, 77, 78, 79, 80, 81, 82, 83, 84, 85, 86, 87, 88, 89, 90, 91, 92, 93, 94, 95, 96, 97, 98, 99, 100	5-6-74	ACE

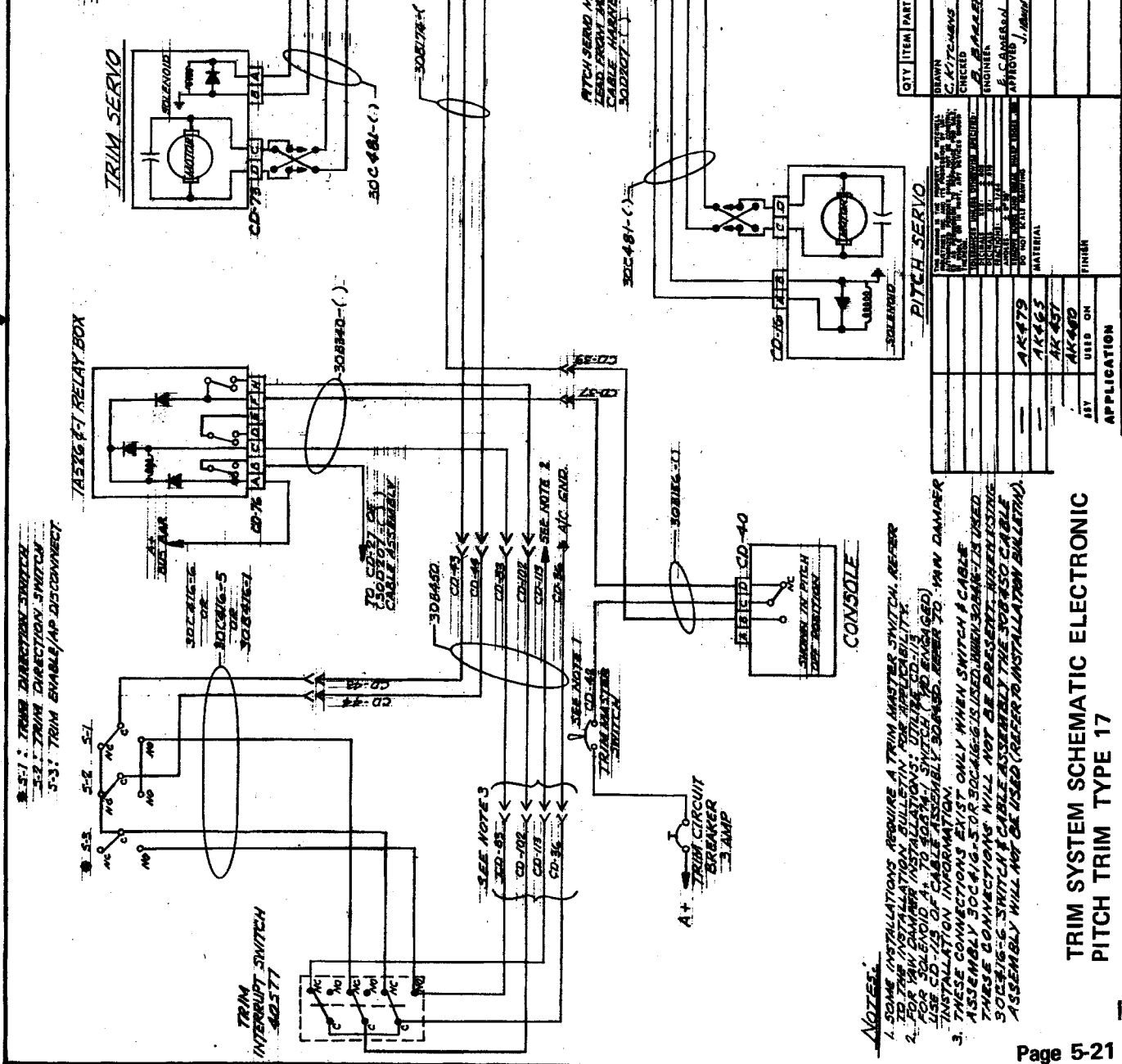

1C709-() ELECTRONIC
PITCH
TRIM AMPLIFIER

FOR INTERNAL WIRING
REFER TO DWG 63035
SCHEMATIC.

- NOTES:**
- SOME INSTALLATIONS REQUIRE A TRIM MASTER SWITCH. REFER TO THE INSTALLATION BULLETIN FOR APPLICABILITY.
 - FOR ANY INSTALLATION, BULLETIN FOR APPLICABILITY. USE FOR SOLENOID A TO WHICH SWITCH CONTACTS ARE WIRING. USE CD-75 OF CABLE ASSEMBLY BOARD. REFER TO "MAN DAMPER" INSTALLATION INFORMATION.
 - THESE CONNECTIONS EXIST ONLY WHEN SWITCH #6 CABLE ASSEMBLY 30C481-1 OR 30C481-2 IS USED. WHEN 30B451-1 IS USED THESE CONNECTIONS WILL NOT BE PRESENT. WHEN USING 30C481-3 SWITCH #6 CABLE ASSEMBLY THE 30B451-1 ASSEMBLY WILL NOT BE USED. (REFER TO INSTALLATION BULLETIN).

QTY	ITEM PART NUMBER	DESCRIPTION
	30C481-1	PITCH SERVO MOTOR FROM AIRCABLE ASSEMBLY 30B451-1
	30C481-2	PITCH SERVO MOTOR FROM AIRCABLE ASSEMBLY 30B451-2
	30C481-3	PITCH SERVO MOTOR FROM AIRCABLE ASSEMBLY 30B451-3

LIST OF MATERIALS	
DRAWN	C. K. WILSON
CHECKED	E. S. ANDERSON
ENGINEER	J. M. JONES
DATE	12-13-73
BY	ACE
USED ON	AK465
APPLICATION	TRIM SYSTEM SCHEMATIC ELECTRONIC PITCH TRIM TYPE 17

EDD-AIRE MITCHELL	
THE TRIM SYSTEM SCHEMATIC ELECTRONIC PITCH TRIM (TYPE 17)	
MINERAL WELLS, TEXAS	DWG NO. 63035
REV	SCALE 1/4"
DATE	12-13-73

- * 5-1: TRIM DIRECTION SWITCH
- * 5-2: TRIM DIRECTION SWITCH
- * 5-3: TRIM ENABLE/MP DISCONNECT

1A526 f-1 RELAY BOX

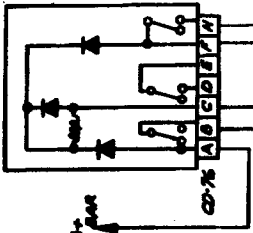

TRIM SERVO

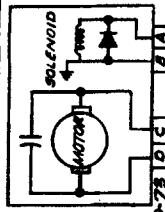

TRIM INTERLOCK SWITCH

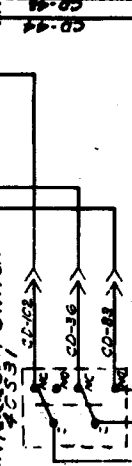

(C709-) ELECTRONIC PITCH TRIM AMPLIFIER
FOR INTERNAL WIRING REFER TO DWG. 630385 SCHEMATIC.

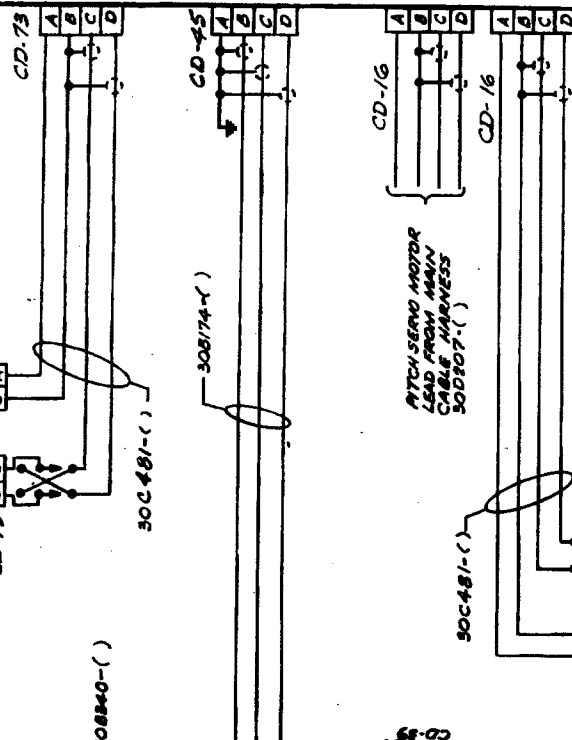

PITCH SERVO MOTOR LEAD FROM MAIN CABLE HARNESS 30D207(-)

30C481(-)

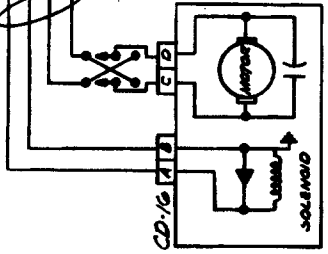

PITCH SERVO

30B56(-)



CD-40

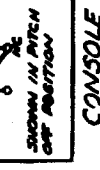

CONSOLE

NOTES:
1. SOME INSTALLATIONS REQUIRE A TRIM MASTER SWITCH. REFER TO THE INSTALLATION BULLETIN FOR APPLICABILITY.

SCHEMATIC TRIM SYSTEM CENTURY III WITH ELECTRONIC PITCH TRIM AMPLIFIER TYPE 18

**SECTION VI
GROUND CHECKS AND FLIGHT ADJUSTMENTS**

6.1 CENTURY II AND IIB AUTOPILOTS

The Century IIB Autopilot is an "Open Loop" system which responds only to the dynamics of the aircraft in flight, thus the only ground checks that can be accomplished are functional checks as described in this bulletin.

For the check procedures described below, it is considered a Century IIB is installed. However, if a Century II is installed, the procedures apply, and both the ON/OFF and the HDG switches are OFF when they are in the OUT position, and they are ON when in the IN position.

6.1.1 GROUND CHECKS:

1. Remove console face plate by removing the roll knob and the two face plate mounting screws that are exposed. After removing the face plate, reinstall the roll knob.
2. Start aircraft engine to obtain Gyro stability. Adjust vacuum regulator to obtain 4.5 to 5.0" vacuum.
3. Center roll knob.
4. Rotate aircraft control wheel to level flight (neutral) position. Push A/P ON/OFF switch ON. Move control wheel right and left to check Servo engagement and that Servo can be overridden.
5. Rotate roll knob right and left and observe that aircraft control wheel is moving the same direction

NOTE: Aircraft control wheel will not necessarily be in any particular position when the roll knob is centered, but will remain stationary at the position it is in at the time the roll knob is rotated to its zero electrical output position.

6. Center Course Selector of Directional Gyro and push HDG switch ON. If Radio Coupler is installed, place Coupler Selector Switch in HDG mode. With the HDG switch ON turns to selected headings are commanded by the HDG knob of the Directional Gyro. The D.G. HDG knob functions by being pushed in and rotated. With the HDG switch ON, the roll knob on the console is inoperative.
7. Rotate D.G. Course Selector right and left from center, and observe that control wheel rotates in the same direction. Return D.G. Course Selector to center.
8. If Radio Coupler is installed, proceed as follows. If coupler is not installed, skip to paragraph 10. Turn on radio and tune receiver to any available omni signal. Check Omni Indicator Needle.
9. Place Radio Coupler in OMNI mode. Swing omni needle right and left slowly and observe that control wheel rotates in the same direction.
10. Turn ON/OFF switch OFF. Rotate control wheel right and left and observe that Servo disengages.

6.1.2 Flight Checks and Adjustments:

The Flight Adjustments required by the Century II and the Century IIB Automatic Flight Control System vary slightly depending upon the Amplifier utilized and the options employed.

The Century IIB Model 1C385, Code change "E", Amplifier requires one adjustment NOT required on the Century II Model 1C385 Amplifier. This adjustment is the Roll Threshold Adjustment given below.

NOTE: If Roll Filter (Century II only) is installed disconnect and leave out of electrical system until Step 15 of Section "C". (Connect CD-18 from console amplifier directly into the Artificial Horizon).

Referencing Fig. 6-1(A), the Century II Adjustment Drawing and Fig. 6-1(B), the Century IIB Adjustment Drawing.

Roll Threshold Adjustment - The Roll Threshold potentiometer is attached to the circuit board of the 1C385 amplifier and is accessible from the front of the amplifier with the face plate removed. (Ref: Ground Checks, Note 1).

1. With the aircraft in smooth air and trimmed for level flight and the A/P ON/OFF switch ON, center the HDG Indice, push HDG switch ON.
2. Adjust the roll threshold potentiometer, ("D", Ref. Fig. 6-1(B)), clockwise until a noticeable roll oscillation develops, (clockwise rotation increases the sensitivity).
3. Rotate potentiometer counterclockwise until lateral oscillation is eliminated.

NOTE: Counterclockwise rotation past the desired adjustment will cause long term lateral oscillation and possible wandering on established headings.

4. Grasp control wheel and displace aircraft in roll. If no oscillation develops, this completes the threshold adjustment. If roll oscillation develops, turn roll pot counterclockwise until oscillation stops. Repeat until no oscillation is detectable.

Roll Center and Bank Limit Adjustments - No Radio Coupler:

1. Fly aircraft to smooth air and trim for level flight using 75% power.

NOTE: Check for rudder trim. If rudder is incorrectly trimmed, the Century IIB will fly the aircraft with a low wing to compensate for the rudder out of trim condition.

2. Center Roll Knob, push ON/OFF switch ON. Set D.G. Course Selector to D.G. heading (aircraft heading).
3. Turn HDG switch ON. If aircraft does not maintain selected heading, adjust as necessary to center D.G. Course Selector using center adjustment screw (B) on Console (Ref. Fig. 6-1).
4. Rotate D.G. Course Selector 90° to 150° left and observe aircraft bank angle. Adjust left bank screw (A) of Console to obtain 20° bank. (Ref. Fig. 1-6). Rotate adjustment screw clockwise to increase bank angle.

NOTE: Keep D.G. Course Selector at least 25° left of D.G. heading until adjustment is completed.

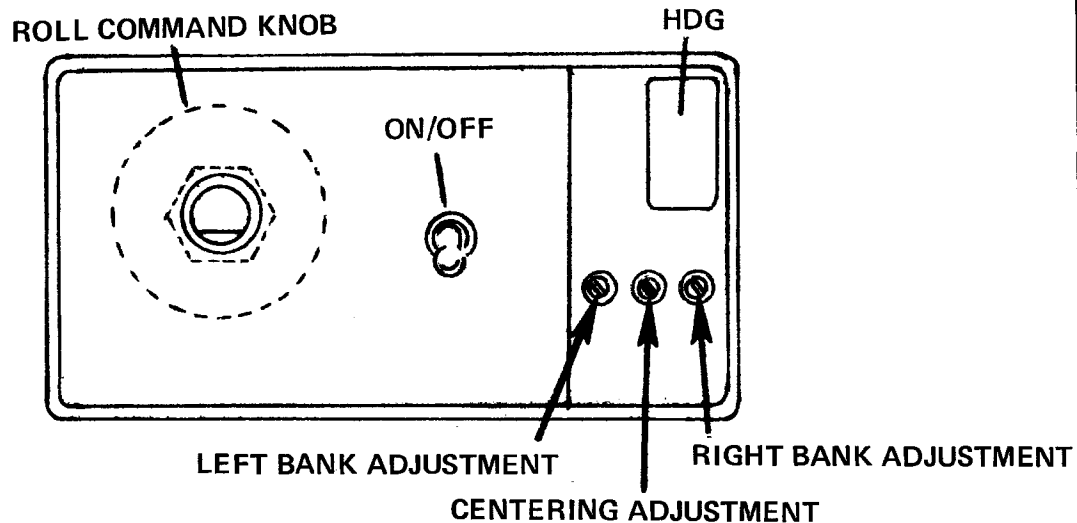

CENTURY II CONSOLE/AMP

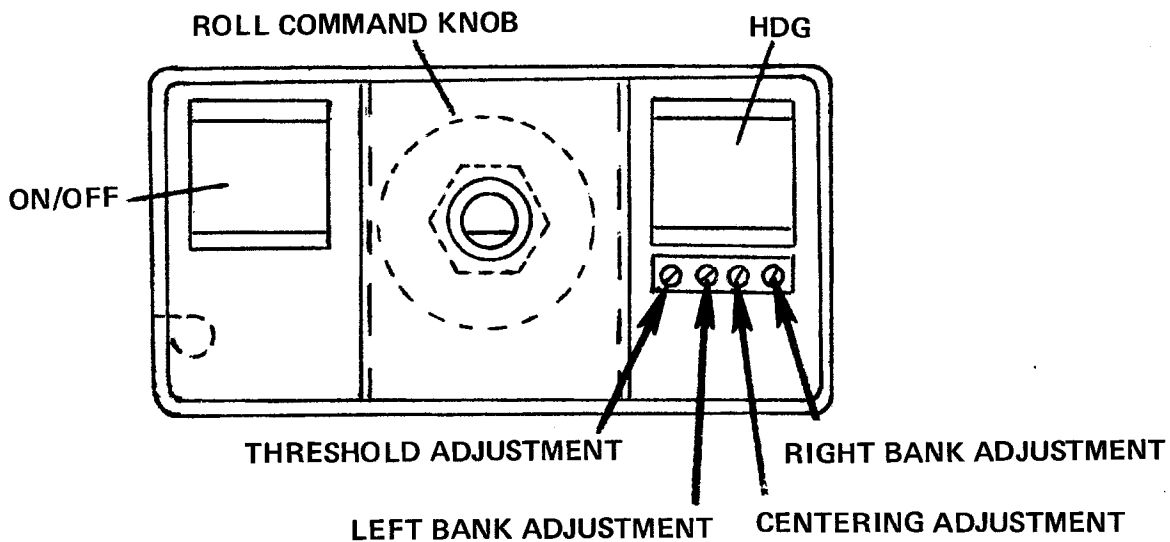

CENTURY IIB CONSOLE/AMP

FIGURE 6-1

5. Rotate D.G. Course Selector 90° to 150° right and observe aircraft bank angle. Adjust right bank screw (C) of console to obtain 20° bank (Ref. Fig. 6-1). Rotate adjustment screw clockwise to increase bank angle.

NOTE: Keep D.G. Course Selector at least 25° right of D.G. heading until adjustment is completed.

6. Allow aircraft to return to selected heading and level flight. Observe that Autopilot maintains selected heading $\pm 2^{\circ}$. If not, repeat steps 2 and 3 until selected HDG is maintained.
7. Push HDG switch OFF and with roll knob centered, observe that aircraft flew wings level $\pm 2^{\circ}$. (With A/C level, roll knob will not necessarily be centered).
8. Turn roll knob full left and observe that aircraft banks left $30^{\circ} \pm 2^{\circ}$.
9. Repeat step 8 to the right, using the right bank screw (C) of console.

ROLL CENTER AND BANK LIMIT ADJUSTMENTS - WITH RADIO COUPLER

1. Fly aircraft to smooth air and trim for level flight using 75% power.

NOTE: Check for correct rudder trim. If rudder is incorrectly trimmed, the Century IIB will fly the aircraft with a wing low to compensate for the rudder out of trim condition.

2. Push ON/OFF switch ON.
3. Set D.G. Course Selector to match D.G. heading (Centered), for drift reference.
4. Push HDG switch ON. Set Coupler Selector Switch to OMNI mode, and push red button on rear of coupler IN. Hold button IN until the centering adjustment is complete.
5. Allow aircraft Roll Attitude to stabilize and if necessary adjust for straight and level flight (wings level and ball centered) with center adjustment screw (B) in console (Ref. Fig. 6-1). After each adjustment allow aircraft attitude to stabilize and observe it for two minutes to insure aircraft is maintaining straight flight. Observe heading drift at HDG indice, maintain red button IN until no drift is detectable during a 30 second period.
6. Place Coupler Selector Switch in the HDG mode, release red button (coupler isolation button), and observe that aircraft maintains selected heading $\pm 2^{\circ}$.
7. Rotate D.G. Course Selector 90° to 150° left and observe aircraft bank angle. Adjust left bank screw (A) of console (Ref. Fig. 6-1) to obtain 20° bank. Rotate adjustment screw clockwise to increase bank angle.

NOTE: Keep D.G. Course Selector at least 25° left of D.G. heading until adjustment is complete.

8. Repeat Step 7 to the right, using the right bank screw (C) of console, (Ref. Fig. 6-1).
9. Set omni Bearing Selector to obtain full left needle deflection.

NOTE: Full left needle deflection must be maintained until adjustment is complete. This can best be accomplished by being at least 20 miles from the omni station and flying approximately to or from the station.

10. Push HDG switch OFF and set D.G. Course Selector 45° right of center indice.
11. Push HDG switch ON and allow aircraft heading to stabilize.
12. Adjust left intercept screw on side of Radio Coupler as necessary to stabilize Course Selector 45° right of center indice. Turn adjustment screw clockwise to increase intercept angle.
13. To adjust right intercept angle, repeat steps 9 through 12 with omni needle deflected full right and Course Selector 45° to left of center indice. Adjust right intercept pot.
14. Center omni needle to a "TO" bearing, and set Course Selector to match omni bearing. Allow aircraft to fly to the omni station and observe that omni needle stays "centered". If omni needle does not maintain center, adjust ROLL center potentiometer (B) CW for a needle displaced to the right of center, and CCW for a needle displaced to the left of center. (Ref. Fig. 6-1). This adjustment needs to be made in ONE TURN increments or less, for a "FINE" adjustment.
15. If Roll Filter is installed, reconnect into system as called out in Electrical Section.
16. Slow aircraft back to best angle of climb airspeed and turn roll rate adjustment potentiometer on end of Roll Filter counterclockwise until slow lateral oscillation is apparent. Then rotate potentiometer clockwise until no oscillation is detected.
17. Command left and right turns at various airspeeds. A noticeable softening in roll rate should be apparent. Bank limits should be the same, if not, adjust as in step 7 of Section "C".
18. This completes the Ground and Flight Checks and Adjustments. Reinstall the Radio Coupler and Console/Amplifier face plate. Check coupler and console wiring for security and clearance.

6.2 CENTURY III AUTOPILOTS

The Century III Autopilot is an "Open Loop" system which responds only to the dynamics of the aircraft in flight, thus the only ground checks that can be accomplished are functional checks as described in this bulletin.

Century III Autopilots may be equipped with any one of the following Amplifiers; 1D395, 1C515 or 1C515-1-2, depending upon the dynamic response required. Although these Amplifiers are physically interchangeable, only the Amplifier model called for in the installation data is approved for that installation.

If the aircraft installation calls for a 1C515-() Amplifier, the aircraft should be loaded to or near its aft C.G. limit for the set-up flight test to obtain the most consistent results. Consult aircraft weight and balance data and assure that the fuel burn during test does not place the aircraft outside the C.G. envelope. Other Amplifier models do not require this loading and should be loaded with full fuel and two people.

For all models, fly aircraft to smooth air and adjust power and configuration for a 65% - 75% power cruise condition, except where otherwise specified.

6.2.1 GROUND CHECKS

Roll

1. Remove Console Face Plate by removing the roll knob and the three face plate retaining screws. After removing the face plate, reinstall the roll knob.
2. Start aircraft engine to obtain Gyro stability. Adjust vacuum regulator to obtain 4.5 to 5.0" vacuum. (Refer to aircraft manufacturer service information).
3. Rotate aircraft control wheel to level flight (neutral) position. Center roll knob. Push ROLL ON/OFF switch ON. Override Servo by manually rotating control wheel right and left through full travel to determine that Servo is engaged and can be overridden.
4. Rotate roll knob right and left and observe that aircraft control wheel is moving in the same direction.

NOTE: Aircraft control wheel will not necessarily be in any particular position when the roll knob is centered, but will remain stationary at the position it is in at the time the roll knob is rotated to its zero electrical output position.

5. Center Course Selector of Directional Gyro and push HDG switch ON, if Radio Coupler is installed, place Coupler Selector Switch in HDG mode. With the HDG switch ON, turns and selected headings are commanded by the HDG knob of the Directional Gyro. The D.G. HDG knob functions by being pushed IN and rotated. With the HDG switch IN, the roll knob on the console is inoperative.
6. Rotate D.G. Course Selector right and left from center, and observe that control wheel rotates in the same direction. Return D.G. Course Selector to center.
7. If Radio Coupler is installed, proceed as follows: (If Coupler is not installed, proceed to Step 9). Turn on Radio and tune receiver to any available OMNI signal. Check OMNI Indicator needle.
8. Place Radio Coupler in OMNI mode. Swing OMNI needle right and left slowly and observe that control wheel rotates in the same direction.
9. Push HDG switch OFF. Push ROLL ON/OFF switch OFF. Rotate control wheel right and left and observe that servo disengages.
10. If equipped with control wheel disconnect, re-engage autopilot and disengage with wheel switch.

Pitch

1. Push ROLL ON/OFF switch ON and position roll knob to stop Roll Servo.

NOTE: If Automatic Trim is installed, pull trim circuit breaker to cut off trim during ground checks.

2. Observe pitch effort meter and center meter by rotating Pitch Command Knob.
3. Push PITCH ON/OFF switch ON. Override Servo by manually moving control wheel full forward and full aft to determine that Servo is engaged and can be overridden. Rotate Pitch

Command Knob full up and observe that control column moves aft.

NOTE: During ground operation, it may be necessary to manually assist control column movement as the Servo clutch may not be capable of moving the control column with its static friction.

4. Rotate Pitch Command Knob full down and observe that control column moves forward.
5. Center Pitch Command Knob.

NOTE: Control column will not necessarily move to or maintain neutral position when Pitch Command Knob is centered, but will cease movement anytime pitch axis is at its electrical center as indicated by a centered trim needle.

6. Push ROLL ON/OFF switch OFF. Move control column fore and aft and observe that Pitch Servo disengaged satisfactorily.

6.2.2 Ground Checks and Adjustment - Automatic Pitch Trim

After installation is complete, the automatic trim sensor must be adjusted for centering. The trim sensor point gap (overall) determines the sensitivity of the trim sensor and is factory set. If an adjustment for trim sensitivity is deemed necessary, consult Section II of this manual for gap tolerances and settings.

Centering Adjustments

1. Support the aircraft elevator at the control surface, in approximately the neutral position to simulate flight conditions.
2. Lightly apply pressure to control yoke fore and aft to remove all influence of the static friction in the control system.
3. Point Adjustment - Cam Type
 - A. Loosen the contact point bracket attaching screws at both ends.
 - B. One end has the attaching screw centered on a hex nut adjusting Cam - Turn the Cam Clockwise or Counterclockwise as necessary to center the contact points on either side of the contact block. Tighten the attaching screws.
 - C. Make preliminary test by touching top of elevator cables alternately with sufficient pressure to close the contact point. The points are "centered" when the pressure required to close the points is approximately equal on either elevator cable. When the pressure is equal the physical point gap in inches might or might not be equal.
 - D. Ground Check by energizing system and depressing control wheel switch. Pull back gently on control wheel, trim should begin to drive up. Relax pressure and then apply pressure forward, trim should begin to drive down. The force required to cause the trim to operate will be approximately 10 lbs., and should be approximately equal for up and down.
 - E. Repeat A through D above until adjustment is satisfactory.
4. Point Adjustment - Set Screw Type
 - A. This type contact point bracket does not have the eccentric cam type adjuster. The contact points are moved by loosening the attaching screws at both ends and sliding the point bracket as required to obtain a proper adjustment per C and D above. After adjustment, tighten two lock screws.

5. Point Adjustment - Dual Contact

- A. The dual contact trim sensor may be equipped with either the cam type or the set screw type adjustable contact points.
- B. For Center Adjustment, loosen one contact set from the sensor base plate to keep the two sets from interfering with one another.
- C. Perform Center Adjustment on the remaining contact set per items 1 through 3C above, using the instructions applicable to the type of adjustment employed. Dual contact sensors can be equipped with either the cam type or set screw type contact adjustment.
- D. Reinstall the first contact set and perform Center Adjustment as described in Sections 1 through 3 and/or step 4 as applicable.
- E. After both sets have been approximately centered, the final centering adjustments can usually be performed on one set of points.

6.3 AUTOMATIC PITCH TRIM SYSTEMS (AUTOTRIM)

6.3.1 General

Edo Avionics manufactures several different type trim systems. These systems vary in method of operation and in detail design and certification requirements. Some models utilize the fail safe concept of malfunction or runaway protection. In this type trim installation the system can withstand any type single failure, anywhere, without uncontrolled operation resulting. These trim systems often employ high trim rates that are operationally better suited to the aircraft model that could be used with a conventional electric trim system. It is very important to never use a substitute trim system component part for an original design part because the fail safe characteristics of the system might be sacrificed. It is also very important to conduct a thorough trim system check, both "ON" autopilot and "OFF" autopilot prior to the first flight, to assure that servo direction is correct in both modes. A trim system running the wrong direction is the same as a runaway. In some cases it is possible to obtain pilot stick forces in excess of 100 pounds in 3-4 seconds under these conditions, therefore always check the system thoroughly for proper function and direction prior to the first set-up flight.

All current Edo-Aire Mitchell trim systems function identically during autotrim mode, however, when operating with autopilot "OFF", two basic methods of operation are used. One method employs the single push button on the control wheel. This system utilizes the trim sensor for direction sensing. The other type uses either a two section rocker switch or a double toggle switch. The rocker switch has a center bar that must be depressed in conjunction with rocking the switch fore and aft for trim operation to occur. All of the above systems can employ the fail safe system design.

Proceed as follows for system check-out:

6.3.2 Ground Checks

Command Type Control Wheel Switch - Rocker Type

1. When the command switch is used on the control wheel then the following functions apply:
 - A. When top bar is depressed and released, it disconnects the autopilot.
 - B. While top bar is depressed and switch is moved aft, it will command an up trim.
 - C. While top bar is depressed and switch is moved forward, it will command a down trim.

NOTE: If system is operating correctly, no trim action will occur unless both actions are performed.

2. Pitch Trim is automatically accomplished when the autopilot is engaged. To check the automatic trim proceed with Step 6.

Push Button Automatic Trim Control Wheel Switch

3. The push button on the top left hand portion of the pilot's control wheel has three functions:
 - A. When pressed and released, it disconnects the autopilot.
 - B. When held down, it engages the automatic trim to trim off control pressures.
 - C. When held down, it disengages roll servo, if optional stabilizer back-up is installed.
4. Engage trim push button and move yoke to aft limit - Trim should trim UP. Push yoke to forward stop - Trim should trim DOWN.
5. With trim button engaged, check servo override by manually operating the trim system. Release trim button - check manual trim to see that trim servo disengaged.
6. Pitch Trim is automatically accomplished when the autopilot is engaged. To check automatic trim proceed as follows:
 - A. Engage autopilot and rotate pitch command disc to the full down position, and note trim system trims nose down.
 - B. Rotate pitch command disc to full up position, and note that trim system trims nose up. (It might be necessary to supply additional control wheel pressure on the ground due to low autopilot authority.)
 - C. Momentarily depress trim switch on control wheel to turn off autopilot.

NOTE: In autopilot mode there will be approximately a three (3) second time delay between the pitch command and the operation of the trim during the ground check.

Command Type Control Wheel Switch - Double Toggle

7. This switch assembly uses two separate center off toggle switches. The switch toggles are connected by a specially designed, loose fitting, knob. To check system operation, proceed as follows:
 - A. Trim circuit breaker - check IN.
 - B. Push switch knob full forward - check nose down trim operation.
 - C. With switch full forward - check override with manual trim system.
 - D. Pull switch knob full aft - check nose up trim.
 - E. With switch full aft - check override with manual trim system.
 - F. Release switch - check that trim disengages.
8. To check autotrim operation proceed as in Step 6 above.

6.4 FLIGHT ADJUSTMENTS FOR 1C515-() AMPLIFIERS

The Flight Adjustments required by the Century III Automatic Flight Control System vary slightly depending upon the Amplifier utilized and the options employed.

The 1C515-() model Amplifier requires two adjustments NOT required on systems equipped with the 1D395 or 1C515 Amplifiers.

INITIAL ADJUSTMENT - 1C515-() ONLY

For these adjustments the amplifier must be inside the cockpit. Remove the amplifier portion of the harness, as necessary to place the amplifier inside for this adjustment, or use a suitable extension harness.

6.4.1 Roll Threshold Adjustment (Rth) - The Roll Threshold potentiometer is attached to the circuit board of the 1C515-1 or 1C515-2 amplifier and is accessible from the bottom of the amplifier with the base plate removed.

CAUTION: During autopilot operation, care must be exercised to assure that the larger power transistors on the side heat sinks do not become grounded to the airframe or internal damage to the amplifier will result.

1. With the aircraft in smooth air and trimmed for level flight, engage the Roll and HDG section of the autopilot and center the HDG indice.
2. Adjust the roll threshold potentiometer clockwise until a noticeable roll oscillation develops (clockwise rotation increases the sensitivity).
3. Rotate potentiometer counterclockwise until lateral oscillation is eliminated.

NOTE: Counterclockwise rotation past the desired adjustment will cause long term (one cycle in 20 seconds) lateral oscillation and possible wandering on established headings.

4. Grasp control wheel and displace aircraft in roll. If no oscillation develops, proceed to pitch adjustment. If roll oscillation develops, turn roll pot counterclockwise until oscillation stops. Repeat until no oscillation is detectable.

6.4.2 Pitch Threshold Adjustment (Pth) - The Pitch Threshold potentiometer is attached to the circuit board of the 1C515-1 amplifier and is accessible for adjustment by removal of the cover plate on top of the amplifier.

1. With the aircraft in smooth air, engage the roll, HDG, and ALT HOLD sections of the autopilot.
2. Turn the pitch threshold pot clockwise until the control wheel begins a noticeable oscillation in pitch, then gradually turn the pot counterclockwise until the oscillation is undetectable.

NOTE: This oscillation might show up as an actual oscillation of the aircraft in pitch attitude or simply as "choppy" control action. If no oscillation is obtained, turn pot 1-2 turns counterclockwise and proceed with 3.

3. Using the pitch command disc, command a climb attitude and observe that the aircraft changes attitude smoothly without a "stair step" type action. If the attitude change is smooth, proceed with C. If "stair stepping" occurs during the attitude change, turn the pitch counterclockwise in one turn increments, changing attitude between adjustments, until attitude changes can be made smoothly.

6.4.3 Engage altitude hold mode and allow aircraft to stabilize. If an oscillation can be felt, turn pitch threshold pot counterclockwise in one turn increments, until oscillation is eliminated or can no longer be felt.

This completes the threshold adjustments. Proceed with the standard Century III Set-up.

6.5 FLIGHT ADJUSTMENTS - ALL CENTURY III

6.5.1 Roll - No Radio Coupler

1. Fly aircraft to smooth air and trim for level flight, using 75% power.

NOTE: Check for correct rudder trim. If rudder is incorrectly trimmed, the Century III will fly the aircraft with a wing low to compensate for the rudder out of trim condition.

2. With roll knob centered, push ROLL ON/OFF switch ON set D.G. Course Selector to D.G. heading.
3. Push HDG switch ON. If aircraft does not maintain selected heading, adjust as necessary to center adjustment screw (B) on console. (Ref. Fig. 6-2).
4. Rotate D.G. Course Selector 90° to 150° left and observe aircraft bank angle. Adjust left bank screw (A) of console to obtain 20° bank. (Ref. Fig. 6-2). Rotate adjustment screw clockwise to increase bank angle.

CAUTION: Keep D.G. Course Selector at least 25° left of D.G. heading until adjustment is completed.

5. Rotate D.G. Course Selector 90° to 150° right and observe aircraft bank angle. Adjust right bank screw (C) of console to obtain 20° bank. (Ref. Fig. 6-2). Rotate adjustment screw clockwise to increase bank angle.

CAUTION: Keep D.G. Course Selector at least 25° right of D.G. heading until adjustment is completed.

6. Allow aircraft to return to selected heading and level flight. Observe that Autopilot maintains selected heading $\pm 2^{\circ}$. If not, repeat steps 2 and 3 until selected heading is maintained.
7. Push OFF HDG switch and with roll knob centered, observe that aircraft flies wings level $\pm 2^{\circ}$.
8. Turn roll knob full left and observe that aircraft banks left $30^{\circ} \pm 2^{\circ}$.
9. Repeat step 8 to the right.

6.5.2 Roll - With Radio Coupler

1. Fly aircraft to smooth air and trim for level flight.
2. Set Coupler Selector Switch to OMNI.
3. Set D.G. Course Selector to match D.G. heading (centered).
4. Push ROLL ON/OFF switch ON. Depress red button on rear of coupler and hold IN until following adjustments are completed. Push HDG switch ON.
5. Allow aircraft Roll Attitude to stabilize and if necessary adjust for straight and level flight (wings level and ball centered) with center adjustment screw (B) in console (Ref. Fig. 6-2). After each adjustment, allow aircraft attitude to stabilize and observe it for two minutes to ensure aircraft is maintaining level flight. Release coupler adjustment switch.
6. Place Coupler Selector Switch in the HDG mode and observe that aircraft maintains selected heading $\pm 2^{\circ}$.
7. Rotate D.G. Course Selector 90° to 150° left and observe aircraft bank angle. Adjust left bank screw (A) of console (Ref. Fig. 6-2) to obtain 20° bank. Rotate adjustment screw clockwise to increase bank angle.
8. Repeat step 7 to the right.

CAUTION: Keep D.G. Course Selector at least 25° left of D.G. heading until adjustment is completed.

9. Turn on Radio and set OMNI Bearing Selector to obtain full left deflection.

NOTE: Full left needle deflection must be maintained until adjustment is completed. This can best be accomplished by being at least 20 miles from the OMNI station and flying approximately to or from the station.

10. Push HDG switch OFF and set D.G. Course Selector 45° right of center indice.
11. Push HDG switch ON and allow aircraft heading to stabilize.
12. Adjust left intercept screw on side of Radio Coupler as necessary to stabilize Course Selector 45° right of center indice. Turn adjustment screw clockwise to increase intercept angle.
13. To adjust right intercept angle, repeat steps 9 through 12 with OMNI needle deflected full right and Course Selector 45° to left of center indice.
14. Center OMNI needle on a "TO" bearing, and set Course Selector to match OMNI bearing. Allow aircraft to fly to the OMNI station and observe that OMNI needle stays "Centered". If OMNI needle does not maintain center, repeat steps 2 through 5.

NOTE: If aircraft flies straight and level with adjustment switch depressed, but does not fly OMNI needle centered, reject the 1C388-M Coupler.

6.5.3 Pitch

1. With aircraft loaded with full fuel and two people, fly aircraft to smooth air. Trim aircraft for level flight, using 75% power.
2. Push ROLL ON/OFF switch ON, adjust Roll Command Knob for wings level. Center Pitch effort meter by rotating Pitch Command Knob.
3. Observe aircraft's indicated altitude and push ALT switch ON. Allow aircraft to stabilize and observe that aircraft is holding the same altitude at which the ALT switch is pushed ON. If aircraft does not hold engage altitude, adjust Pitch centering screw "E" (Ref. Fig. 6-2) until aircraft does hold engage altitude.

NOTE: Turn screw clockwise to increase altitude.

4. Push PITCH ON/OFF switch OFF, again note indicated altitude and push ALT switch ON and allow aircraft to stabilize and observe that aircraft is holding engage altitude. Repeat steps 3 and 4 until correct results are obtained on two consecutive steps.
5. Center Pitch Command Knob, and push ALT switch OFF.
6. Rotate Pitch Command Knob if necessary to maintain level flight. After aircraft is stabilized level, observe that Pitch Command Knob is centered $\pm 1/8''$.
7. Rotate Pitch Command full up and adjust pitch up limit screw "F" (Ref. Fig. 6-2) to obtain a climb airspeed of approximately 1.2% of stall speed. Turn screw clockwise to increase climb angle.
8. Rotate Pitch Command Knob full down and reduce power to 18"-20" h.g. After aircraft

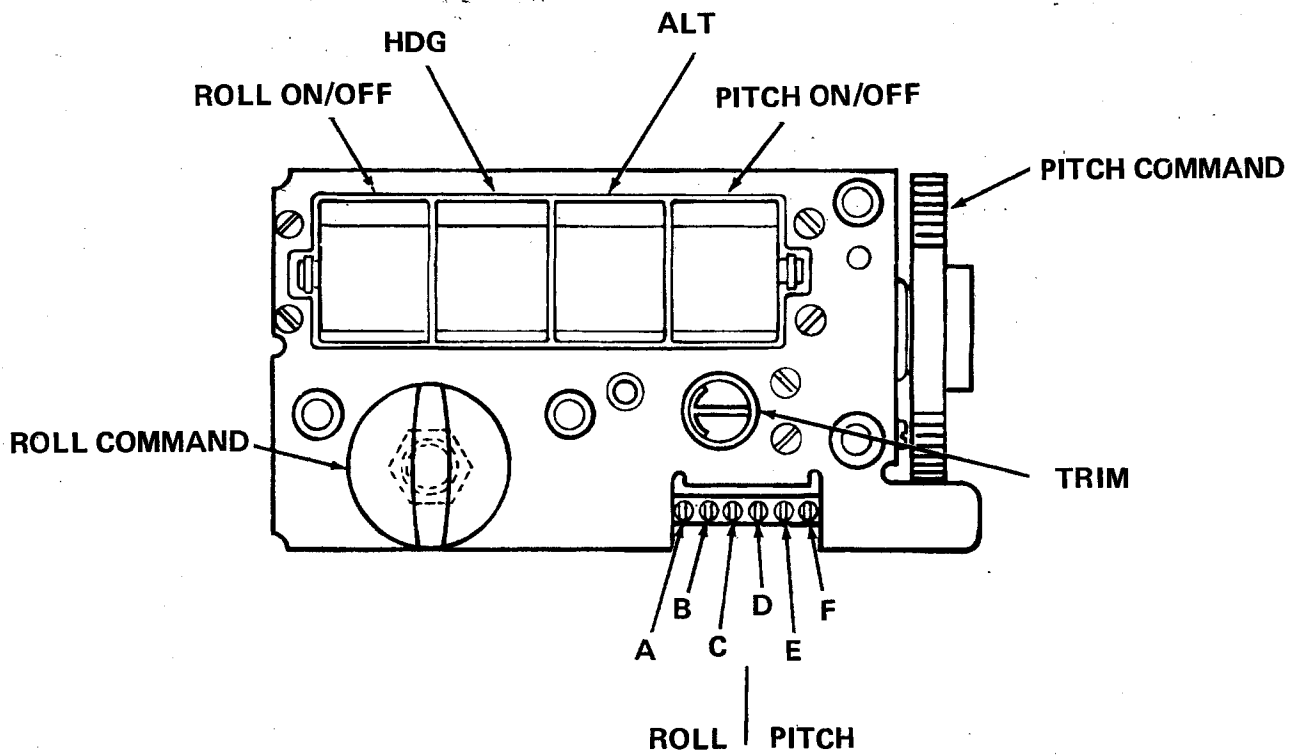

- | | | | |
|---|----------------|---|------------------|
| A | LEFT BANK | D | PITCH DOWN LIMIT |
| B | ROLL CENTERING | E | PITCH CENTERING |
| C | RIGHT BANK | F | PITCH UP LIMIT |

CENTURY III CONSOLE (1C404)

FIGURE 6-2

has stabilized, adjust pitch down limit screw "D" (Ref. Fig. 6-2) to obtain aircraft Vc speed (end of green arc).

CAUTION: It may be necessary to reduce power to prevent excess speed.

9. Slow aircraft to approach speed and configure aircraft as required for normal ILS approach. (Consult A.F.M. Supplement). Check the down range of adjustment available for adequacy in this configuration. Increase the down limit if necessary by readjusting Pot. "D".

NOTE: Climb and descent speed may be adjusted to any desired speed that is within the approved airspeed range.

6.7 GLIDE SLOPE COUPLER

6.7.1 In-Flight Adjustment Procedure for 1C493 Glide Slope Coupler Without 66D94 Test Box

1. Fly outbound on the LOC front course at an altitude of approximately 4000 ft. above the runway elevation.
2. When the distance out is sufficient to assure that the aircraft is well under the glide path, make a normal procedure turn (operate the controls of the radio coupler as per instructions for a normal approach) and allow the aircraft to intercept the ILS.

NOTE: Prior to intercepting the glide path the airspeed should be established (120 MPH typical) and the aircraft should be in the approach configuration.

3. Upon intercepting the glide path (green indicator light shows coupler to be engaged) immediately make a power reduction required to maintain correct airspeeds, and depress button on glide slope coupler box.
4. Adjust pot, adjacent to red button on 1C493 Glide Slope Coupler, as required to track glide path with needle centered (Clockwise is up).

6.7.2 In-Flight Adjustment Procedure for 1C493 Glide Slope Coupler With 66D94 Test Box

1. Connect CD-58 cable from Glide Slope Coupler to CD-34 cable on 66D94 Test Box. (Ref. Fig. 6-3). Switch in position "B".
2. Fly to an area clear of traffic and to an altitude sufficient to make a simulated approach and descent.
3. With Autopilot operating:
 - a. Set Radio Coupler to Localizer Normal.
 - b. Engage Altitude Hold.
4. Establish approach airspeed with gear down.
5. Pull radio knob on and rotate counterclockwise to 100% (blue side). This is equivalent to being under the Glide Slope and is necessary for arming the Glide Slope Coupler.
6. Maintain 100% radio signal for approximately 30 seconds and then slowly rotate radio knob to bring needle to center.

7. As needle crosses center note Glide Slope intercept made (green indicator light on).
8. Push radio knob off. (This is equivalent to center Glide Slope needle).
9. Immediately make power reduction required to maintain correct airspeed.
10. Depress red button on Glide Slope Coupler and adjust adjacent pot to set 500 ft. per minute descent. (Clockwise is up.)
11. Repeat procedure to be sure adjustment is satisfactory.
12. Disconnect Test Box and connect CD-58 from coupler to CD 58 from Glide Slope Indicator. Unit is now ready for actual approach.

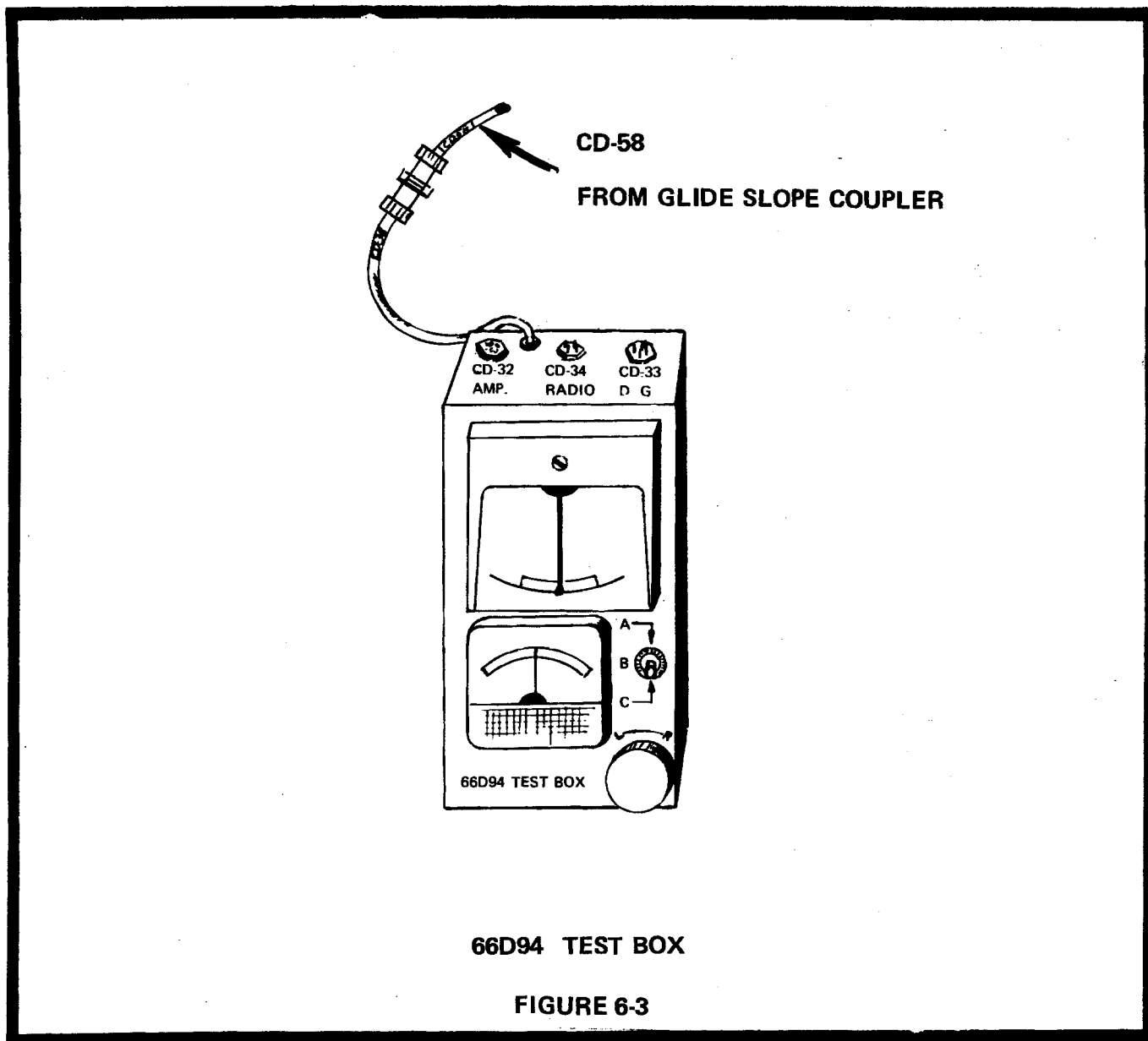

SECTION VII

PARTS LIST

PARTS LIST
TABLE OF CONTENTS

<u>COMPONENT</u>	<u>PAGE</u>
Century II 1C385 Console/Amplifier	7-2
Century II 1C372-1 & -2 Printed Circuit Board	7-4
Century IIB 1C385 Console/Amplifier	7-6
Century IIB 1C338 & 1C385 14 volts Printed Circuit Board Assembly	7-9
Century IIB 1C338 & 1C385 14 volts Printed Circuit Board Assembly	7-10
Century III 1C404 Console	7-12
Century III 1D395 Amplifier	7-14
Century III 1D397 (Used in 1D395) Printed Circuit Board Assembly	7-16
Century III 1D511 (Used in 1C515 Amplifier) Printed Circuit Board Assembly	7-18
Printed Circuit Board Assembly for 1C515-1 & 2 Amplifier	7-20
Printed Circuit Board Assembly for 1C515-1 & 2 (Amplifier) Capacitors and Transformers	7-22
Printed Circuit Board Assembly for 1C515-1 & 2 (Amplifier) Transistors and Diodes	7-24
1C388 Radio Coupler	7-26
1C412 Radio Coupler Printed Circuit Board	7-28
Printed Circuit Board Assembly 1C388, 1C388M, 1C388MC, 1C388-2 (Radio Coupler, SN 6000 & Above	7-30
79D41 Glide Slope Coupler Printed Circuit Board	7-32
Altitude Hold 1C407	7-34
1B369-1 Trim Amplifier	7-36
1B346 Trim Amplifier	7-38
Printed Circuit Board Assembly (14V) Pitch Trim Amplifier (Dual System)	7-40
Pitch Trim Amplifier Dual Sensor 1C646	7-42
Printed Circuit Board Assembly for Trim Amplifier Manual/Automatic 1C671	7-44
Printed Circuit Board Assembly Amplifier, Trim 79C53	7-46
Printed Circuit Board Assembly Amplifier, Trim 79C54	7-48
Printed Circuit Board Assembly Trim Amplifier, 79C54-3	7-50
1C318 Pitch Trim Sensor Assembly	7-52
1C326 Pitch Trim Sensor Assembly	7-53
1C326 Pitch Trim Sensor Assembly	7-54
1C365 Trim Sensor	7-56
1C374 Pitch Trim Sensor Assembly	7-57
1C374 Pitch Trim Sensor Assembly	7-58
1C377 Trim Sensor	7-60
Typical Trim Servo	7-62
Typical Trim Servo	7-63
Table 1 - Trim Servos	7-64
79D51 - 14VDC, 30 RPM Pitch Trim Servo Assembly	7-66
79D52 - 28VDC, 20 RPM Pitch Trim Servo Assembly	7-68
Roll and Pitch Servos - See Table 2	7-70
79B68-() Gear and Capstan Assembly	7-72
1C363-1 Servo Assembly 14VDC, 7.2 RPM	7-74
1C465-1 Servo Assembly 28VDC, 7.2 RPM	7-76
1C470-1 Servo Assembly 28VDC, 1.8 RPM	7-78
1C508-1 Servo Assembly 14VDC, 1.8 RPM	7-80
1C359 Gyro-Amplifier (Used in Stabilizer Back System)	7-82
1C354 Printed Circuit Board Assembly (Stabilizer)	7-84
1B440 Roll Signal Filter	7-86
Printed Circuit Board Assembly Pitch Signal Filter 1B440-1	7-88
1B405 Switch Box	7-90

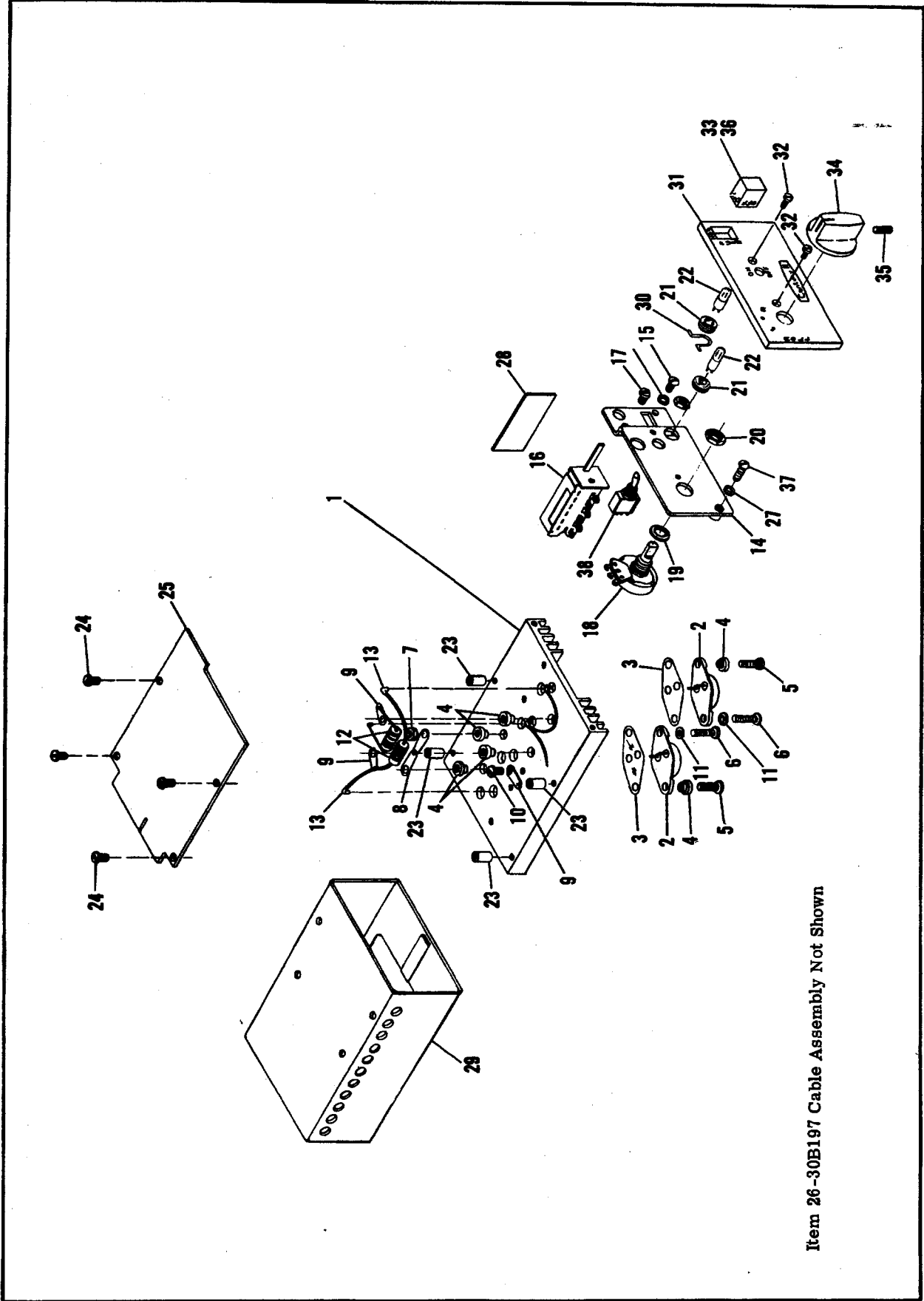

Item 26-30B197 Cable Assembly Not Shown

Figure 11-2. 1C385 Console/Amplifier

CENTURY II
1C385 CONSOLE/AMPLIFIER

ITEM NO.	PART NO.	DESCRIPTION
-1	27B72	CHASSIS
-2	48S43	TRANSISTOR
-3	14A46	INSULATOR
-4	4A58	SHOULDER WASHER
-5	3S164	SCREW 4-40 x 5/16 B. H.
-6	3S212	SCREW 4-40 x 1/2 B. H.
-7	2S14	NUT 4-40 Hex
-8	29S21	SOLDER LUG No. 4 Locking
-9	29S56	SOLDER LUG No. 4 Locking
-10	3S48	SCREW 4-40 x 3/16 B. H.
-11	4S40	LOCKWASHER No. 4 Int.
-12	6R106	RESISTOR 68 Ohm, 2W
-13	29S20	CONNECTOR
-14	7B565-1	BRACKET ASSY.
-15	3S14	SCREW 6-32 x 1/4 R. H.
-16	40A22-3	SWITCH
-17	3S38	SCREW 6-32 x 3/16 B. H.
-18	18A18-1	POTENTIOMETER
-19	4S117	LOCKWASHER 3/8 Int.
-20	2S60	NUT 3/8 - 32 Hex
-21	5S59	GROMMET
-22	65S28	LIGHT (24 V)
-23	43A283	SPACER
-24	3S110	SCREW 4-40 x 5/8 B. H.
-25	1C372	PRINTED CIRCUIT BOARD ASSEMBLY
-26	30B197	CABLE ASSY.
-27	4S90	LOCKWASHER No. 6 Split
-28	13A265	PLACARD S/N
-29	15B163-1	COVER ASSY.
-30	42A171	RETAINING CLIP
-31	13B290	FACE PLATE
-32	3S242	SCREW 4-40 x 1/4 F. H.
-33	36A81-2	KNOB
-34	36A98	KNOB
-35	3S342	SET SCREW 8-32 x 7/16 C. P.
-36	41A70	SPRING CLIP
-37	3S372	SCREW
-38	40S35	SWITCH

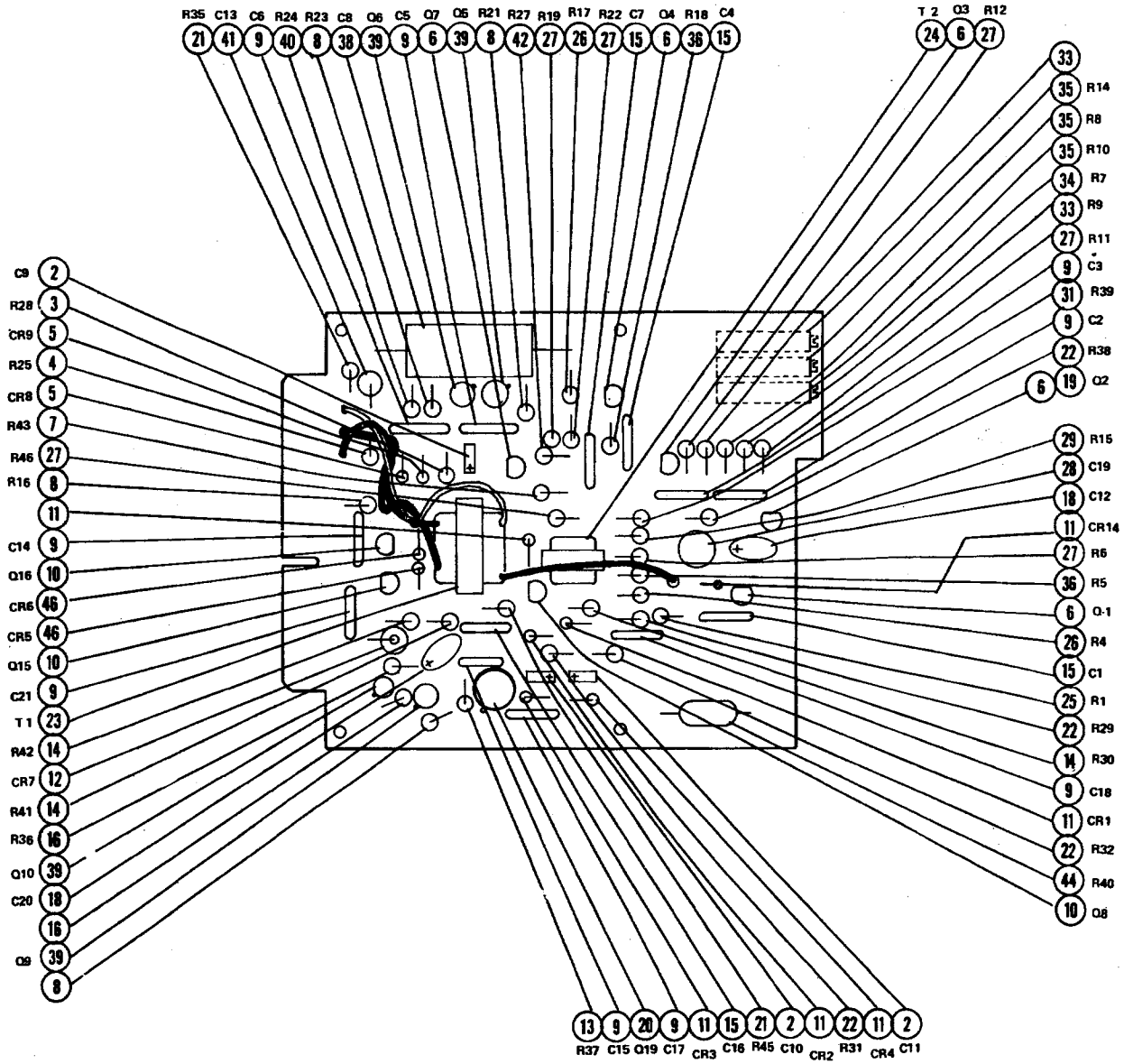

CENTURY II CIRCUIT BOARD

CENTURY II
1C372-1 & -2 PRINTED CIRCUIT BOARD

ITEM NO.	PART NO.	DESCRIPTION
-1	27B73	PRINTED CIRCUIT BOARD
-2	21S85	CAPACITOR 5.6 uf. 20 V. TANT
-3	6356124	RESISTOR 560 ohms 2% ¼ W.
-4	6351224	RESISTOR 5.1 2% ¼ W.
-5	48S61	DIODE
-6	48S49	TRANSISTOR MPS 6515
-7	6320424	RESISTOR, 200K. 2% ¼W.
-8	6310324	RESISTOR 10K, 2% ¼W.
-9	8S14	CAPACITOR 1 uf
-10	48S48	TRANSISTOR MPS 6519
-11	48S33	IN4001
-12	48S38	DIODE 11 VOLT ZENER 1W IN962B
-13	6310122	RESISTOR, 100 ohms 2% ½W.
-14	6310424	RESISTOR 100K 2% ¼W.
-15	21S58	CAPACITOR 22mf
-16	6310022	RESISTOR 10 ohms 2% ½W.
-17	(See Note 4)	TRANSISTOR (See Note 4) (-2 only)
-18	21S139	CAPACITOR 47 uf 20V TANT.
-19	14S151	TRANSISTOR MOUNTING PAD
-20	48S62	TRANSISTOR 2N3116
-21	6368024	RESISTOR 68 ohms 2% ¼W.
-22	6333224	RESISTOR 3.3K 2% ¼W.
-23	25B32	TRANSFORMER
-24	25A23	TRANSFORMER
-25	See Note 1	RESISTOR SELECT
-26	6315424	RESISTOR 150K 2% ¼W.
-27	6347224	RESISTOR 4.7K 2% ¼W.
-28	21S66	CAPACITOR 50 uf.
-29	See Note 5	RESISTOR SELECT
-30		
-31	SELECT	RESISTOR (270K to 390K) 2% ¼W.
-32		
-33	6310224	RESISTOR 1K, 2% ¼W.
-34	6382324	RESISTOR 82K 2% ¼W.
-35	18S31	POTENTIOMETER 20K BECKMAN NO. 79PR20K
-36	6382124	RESISTOR 820 ohms ¼W.
-37		
-38	21S64	CAPACITOR 200 uf ± 10%
-39	48S42	TRANSISTOR 2N3116
-40	6315324	RESISTOR 15K, 2N3116
-41	21S72	CAPACITOR - 022 uf.
-42	6322324	RESISTOR, 22K 2% ¼W.
-43	10M122	WIRE No. 24 (Red & White) (For -2)
-44	6R340	RESISTOR 91 ohms 5% 3W
-45	21S101	CAPACITOR 330 PF.
-46	48S98	DIODE IN4933

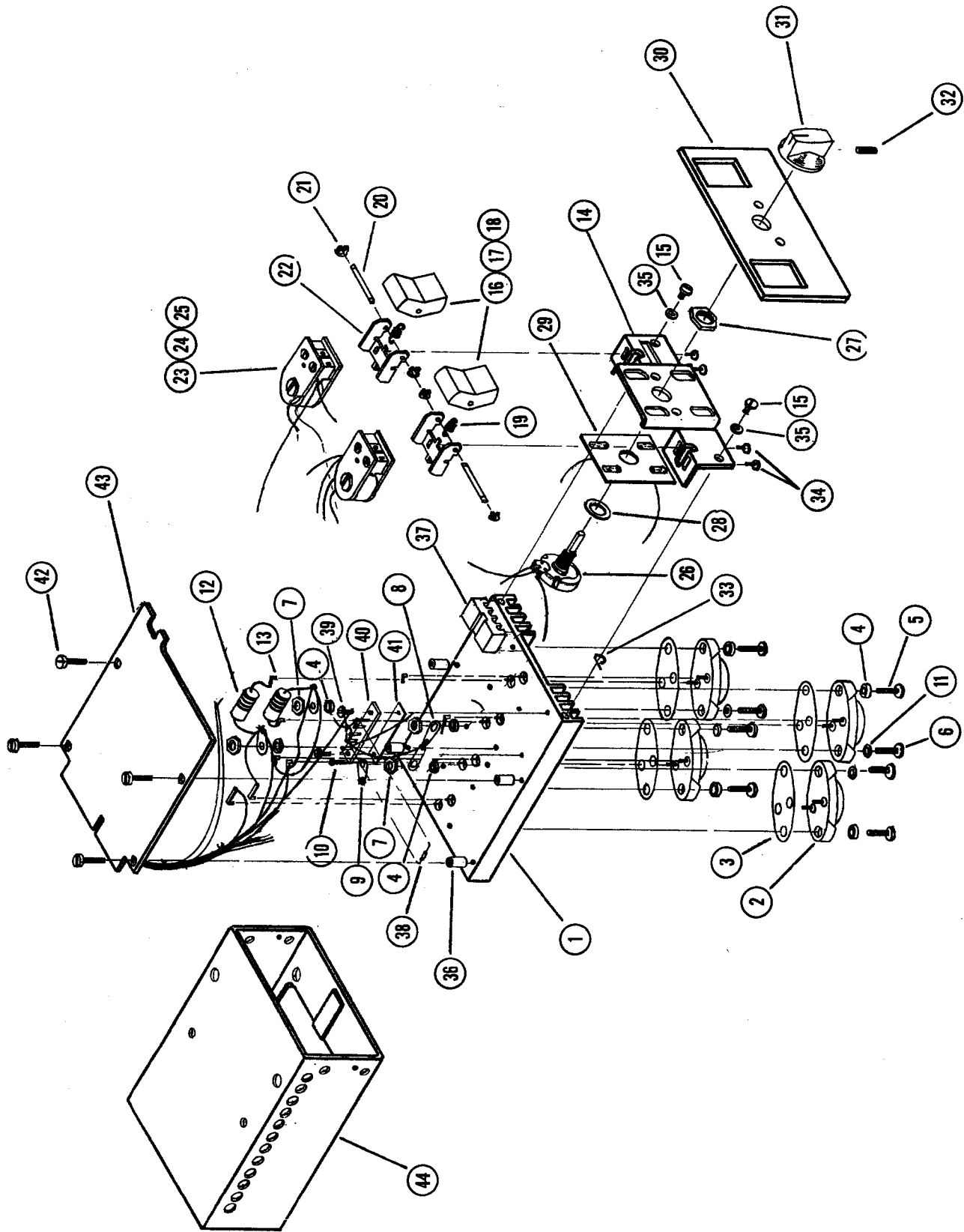

CENTURY IIB
1C385 CONSOLE/AMPLIFIER

ITEM NO.	PART NO.	DESCRIPTION
-1	27B72	CHASSIS "Rev. F"
-2	48S43	TRANSISTOR 2N3055 Motorola
-3	14A46	INSULATOR MICA
-4	4S202	WASHER, SHOULDER
-5	3S164	SCREW, 4-40 x 5/16 B. H.
-6	3S212	SCREW 4-40 x 1/2 B. H.
-7	2S14	NUT 4-40 Hex
-8	29S21	SOLDER LUG, No. 4 Locking
-9	29S56	SOLDER LUG, No. 4 Locking
-10	3S48	SCREW 4-40 x 3/16 B. H.
-11	4S40	LOCK WASHER No. 4 Int. Locking
-12	6R106	RESISTOR 68 OHM, 2W, 10%
-13	29S20	CONNECTOR
-14	7C1217	BRACKET
-15	3S14	SCREW 6-32 x 1/4 R. H.
-16	36A125-2	ACTUATOR
-17	7A606	SPRING ANCHOR PLATE
-18	3S365	SCREW, No. 2 Self Tapping
-19	41A98	SPRING
-20	47A242	SHAFT
-21	42S98	TRU ARC RING 5555-12
-22	7B960	BRACKET
-23	40S27	MICRO SWITCH
-24	1A706	SWITCH MAGNET
-25	7A955	MICRO SWITCH MOUNTING PLATE
-26	18A18-1	POTENTIOMETER 10K
-27	2S60	NUT 3/8 x 32 Hex
-28	4S117	LOCKWASHER 3/8
-29	1B686	PRINTED CIRCUIT BOARD ASSEMBLY
-30	13C659	FACE PLATE
-31	36A98	KNOB
-32	3S342	SET SCREW 8-32 x 7/16 Cup Point
-33	42A248	CLIP, RETAINER
-34	3S131	SCREW 2-56 x 3/16 B. H.
-35	4S90	LOCKWASHER No. 6 Split
-36	43A283	SPACER
-37	46B211	GUIDE
-38	48S33	DIODE
-39	3S27	SCREW 4-40 x 1/4 B. H.
-40	31A52-1	TERMINAL BOARD
-41	14A157	INSULATOR
-42	3S110	SCREW 4-40 x 5/8 B. H.
-43	1D681	P. C. Board Assembly 14V
	1D681-1	P. C. Board Assembly 28V
-44	15B163-1	COVER ASSEMBLY

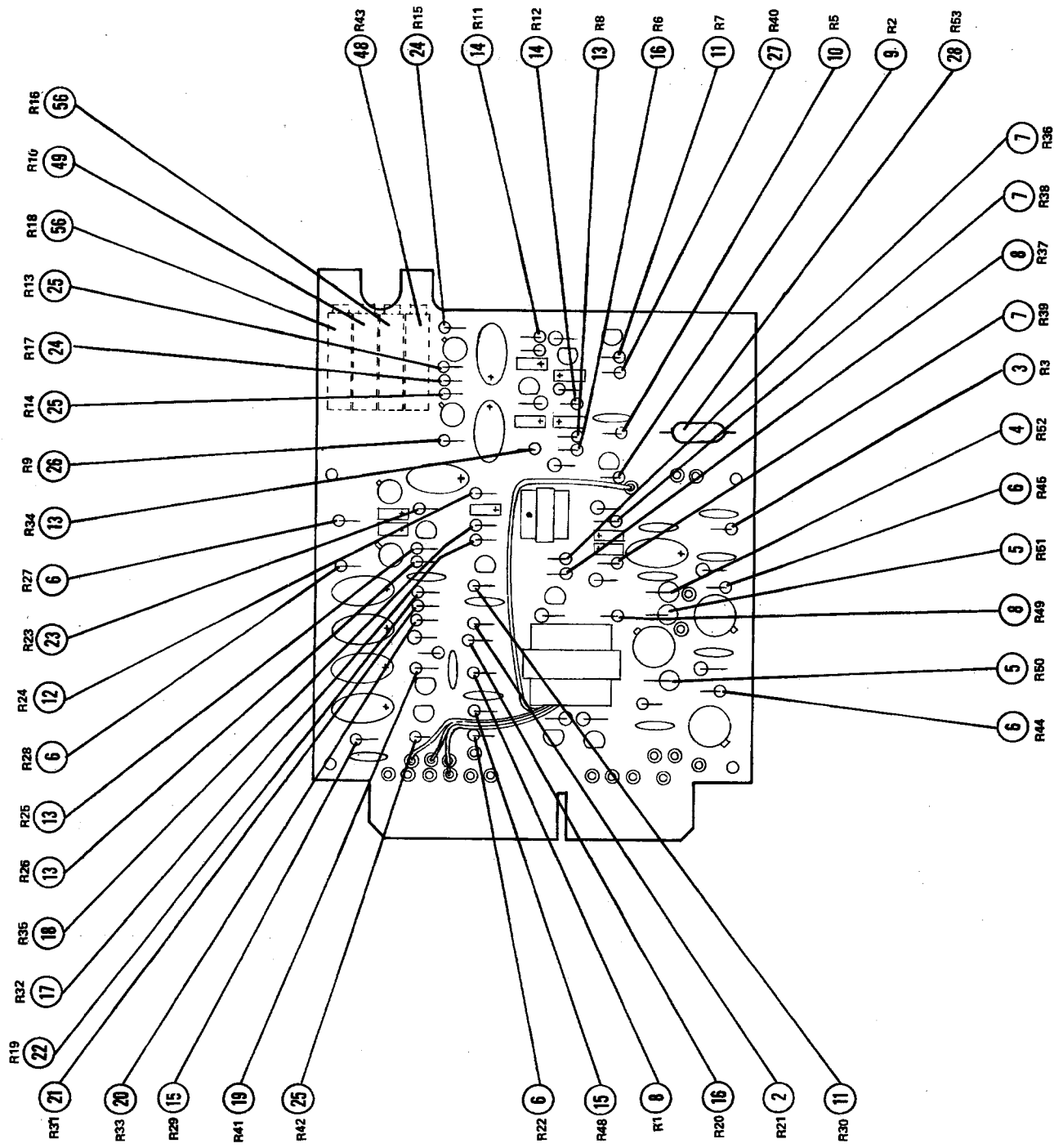

RESISTORS

FIGURE 4-1D (CON'T.)

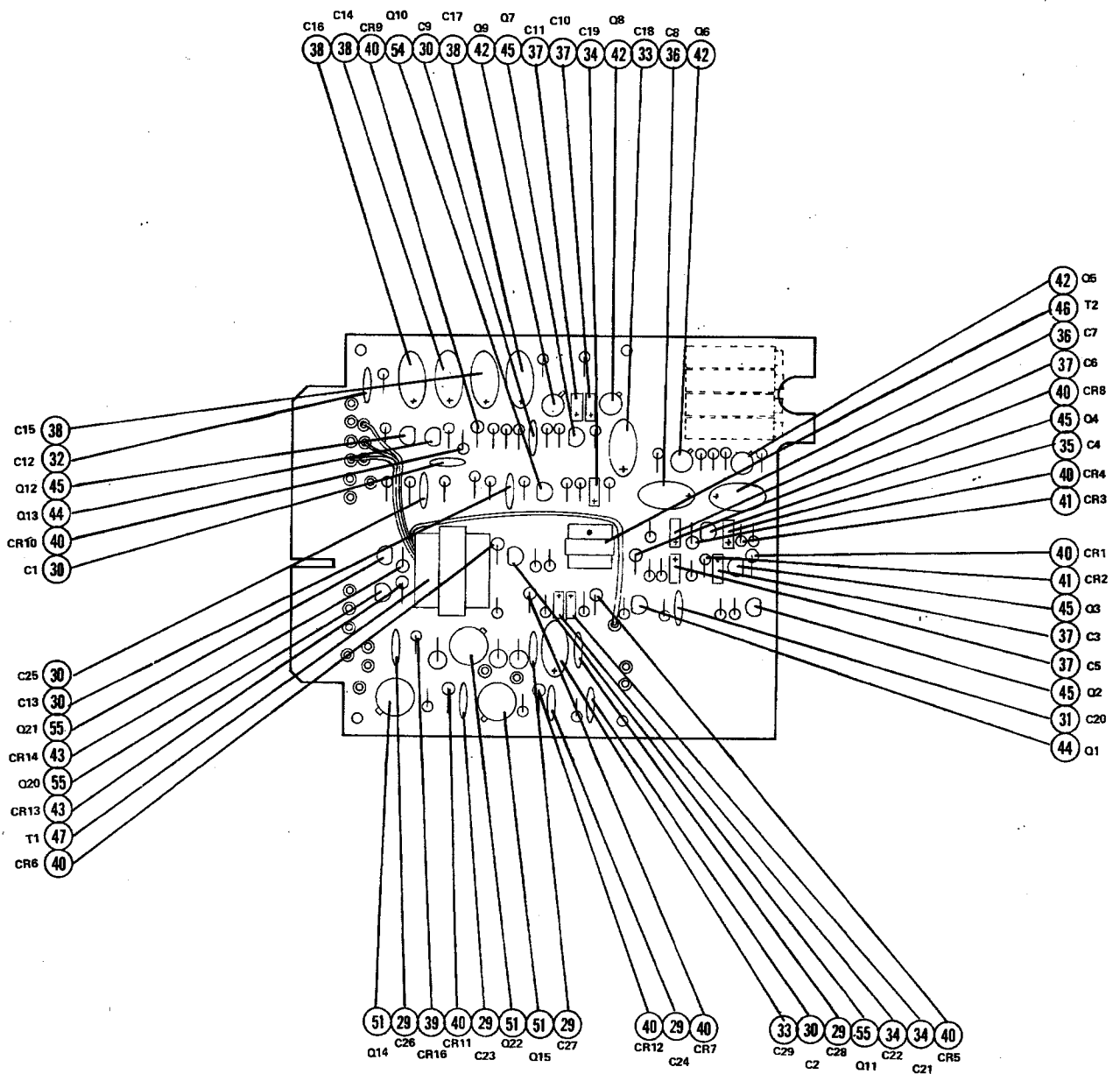

CAPACITORS TRANSISTORS AND DIODES

FIGURE 4-1D

CENTURY IIB CIRCUIT BOARD

CENTURY IIB
PRINTED CIRCUIT BOARD ASSEMBLY
1C338 & 1C385 14 VOLT

ITEM NO.	PART NO.	DESCRIPTION
-1	27C183	PRINTED CIRCUIT BOARD
-2	SELECT	RESISTOR, 22K-56K, 1/4W, 2%
-3	SELECT	RESISTOR, 4.7K-20K, 1/4W, 2%
-4	6310022	RESISTOR, 10 , 1/2W, 2%
-5	6310122	RESISTOR, 100 , 1/2W, 2%
-6	6310324	RESISTOR, 10K, 1/4W, 2%
-7	6333224	RESISTOR, 3.3K, 1/4W, 2%
-8	6310424	RESISTOR, 100K, 1/4W, 2%
-9	6356224	RESISTOR, 5.6K, 1/4W, 2%
-10	6347324	RESISTOR, 47K, 1/4W, 2%
-11	6322424	RESISTOR, 220K, 1/4W, 2%
-12	6382124	RESISTOR, 820 , 1/4W, 2%
-13	6347224	RESISTOR, 4.7K, 1/4W, 2%
-14	6368324	RESISTOR, 68K, 1/4W, 2%
-15	6368024	RESISTOR, 68 , 1/4W, 2%
-16	6327224	RESISTOR, 2.7K, 1/4W, 2%
-17	6322324	RESISTOR, 22K, 1/4W, 2%
-18	6356124	RESISTOR, 560 , 1/4W, 2%
-19	6312224	RESISTOR, 1.2K, 1/4W, 2%
-20	6351224	RESISTOR, 5.1K, 1/4W, 2%
-21	6315324	RESISTOR, 15K, 1/4W, 2%
-22	SELECT	RESISTOR, 270K-390K, 1/4W, 2%
-23	6315424	RESISTOR, 150K, 1/4W, 2%
-24	6310224	RESISTOR, 1K, 1/4W, 2%
-25	6322224	RESISTOR, 2.2K, 1/4W, 2%
-26	6382324	RESISTOR, 82K, 1/4W, 2%
-27	6310124	RESISTOR, 100 , 1/4W, 2%
-28	10M85	SOLDER
-29	21S118	CAPACITOR, CERAMIC, 1 MFD, 50V
-30	21S114	CAPACITOR, CERAMIC, .22 MFD, 50V
-31	21S98	CAPACITOR, CERAMIC, .047 MFD, 50V
-32	21A132	CAPACITOR, CERAMIC, .022 MFD, 50V
-33	21S105	CAPACITOR, TANTALUM, 47 MFD, 25V
-34	21S85	CAPACITOR, TANTALUM, 5.6 MFD, 20V
-35	21A88	CAPACITOR, TANTALUM, 2.2 MFD, 35V
-36	21S116	CAPACITOR, TANTALUM, 100 MFD, 20V
-37	21A86	CAPACITOR, TANTALUM, 1 MFD, 35V
-38	21S126	CAPACITOR, TANTALUM, 220 MFD, 10V
-39	48S38	DIODE, ZENER
-40	48S33	DIODE, IN4001
-41	48S16	DIODE, IN34A
-42	48S42	TRANSISTOR, 2N3116
-43	48S62	TRANSISTOR, 2N3116
-44	48S48	TRANSISTOR, MPS 6519
-45	48S49	TRANSISTOR, MPS 6515
-46	25B23	TRANSFORMER
-47	25B32	TRANSFORMER
-48	18S32	POTENTIOMETER TRIM, 5K
-49	18S31	POTENTIOMETER, TRIM, 20K
-50	11M258	ANTI-FUNGUS SPRAY
-51	48S63	TRANSISTOR, 2N4410

CENTURY IIB
 PRINTED CIRCUIT BOARD ASSEMBLY
 1C338 & 1C385 14 VOLT

ITEM NO.	PART NO.	DESCRIPTION
-52	48S64	TRANSISTOR, 2N4403
-53	48S98	DIODE, IN4933
-54	18S50	POTENTIOMETER, TRIM, 10K

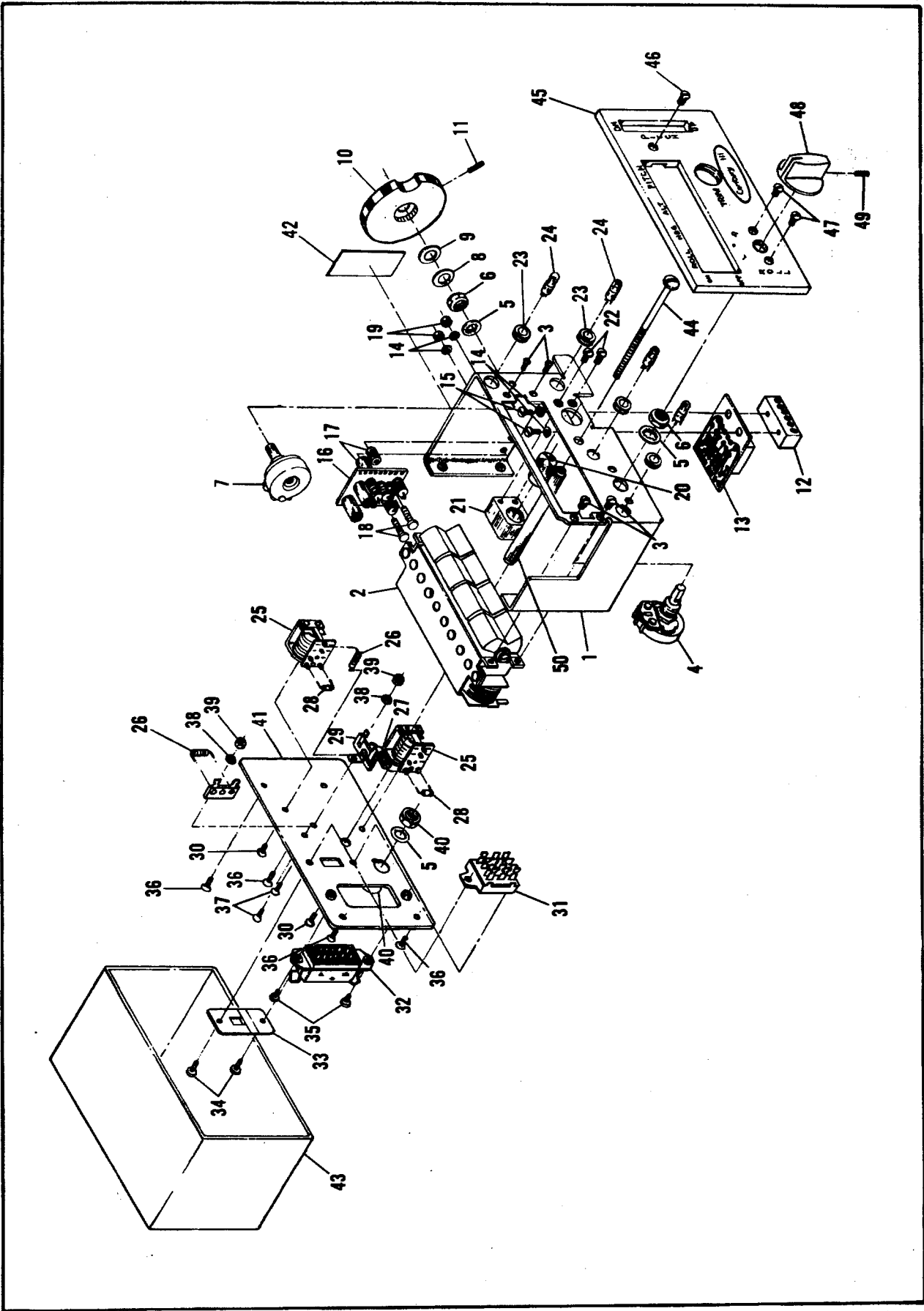

CENTURY III
1C404 CONSOLE

ITEM NO.	PART NO.	DESCRIPTION
-1	27A101-1	CHASSIS SUB ASSEMBLY
-2	40C42	SWITCH ASSEMBLY
-3	3S278	SCREW, 2-56 x 3/16 F. H.
-4	18A18-1	POTENTIOMETER
-5	4S117	LOCKWASHER, 3/8 Int.
-6	2S60	NUT, 3/8-32 Hex
-7	18A18	POTENTIOMETER
-8	4S124	WASHER
-9	4S168	WASHER, Wave
-10	36B124	KNOB
-11	3S259	SET SCREW, 6-32 x 5/16 CP.
-12	46A145	GUIDE, Pot Shaft.
-13	1A400	PRINTED CIRCUIT BOARD ASSEMBLY
-14	4S40	LOCKWASHER, NO. 4 Int.
-15	3S164	SCREW, 4-40 x 5/16 B. H.
-16	1A402-1	PRINTED CIRCUIT BOARD ASSEMBLY
-17	43A313	SPACER
-18	3S110	SCREW, 4-40 x 5/8 B. H.
-19	2S14	NUT, 4-40 Hex
-20	52A32	METER
-21	7A591-1	BRACKET, Trim meter
-22	3S367	SCREW, No. 4 x 3/8 F. H. thd cutting.
-23	5S59	GROMMET
-24	65S28	BULB, Light
-25	80S13	RELAY
-26	6R23	RESISTOR, 3.3K, 1/2W, 10%.
-27	6R147	RESISTOR, 200 Ohm, 1W, 10%.
-28	48S33	DIODE, IN4041
-29	31S41	TERMINAL BOARD
-30	3S361	SCREW, 3-48 x 5/16 F. H.
-31	40S43	SWITCH.
-32	9S80	RECEPTACLE.
-33	7A609-1	SWITCH LIMITER ASSEMBLY
-34	3S27	SCREW, 4-40 x 1/4 B. H.
-35	3S208	SCREW, 1-56 x 1/8 B. H.
-36	3S242	SCREW, 4-40 x 1/4 F. H.
-37	3S66	SCREW, 2-56 x 1/4 F. H.
-38	4S16	LOCKWASHER, No. 2 Int.
-39	2S46	NUT, 2-56 Hex
-40	28S40	PLUG (4 pin)
-41	27A102-1	BACKPLATE ASSEMBLY
-42	13A265	PLACARD
-43	15A188-1	COVER ASSEMBLY.
-44	3S364	SCREW, 8-32 x 3.0 Pan Hd
-45	13B316	FACE PLATE
-46	3S378	SCREW, 4-40 x 5/16 F. H. Bik.
-47	3S266	SCREW, 4-40 x 5/16 F. H.
-48	36A98	KNOB
-49	3S342	SET SCREW, 8-32 x 7/16 C. P.

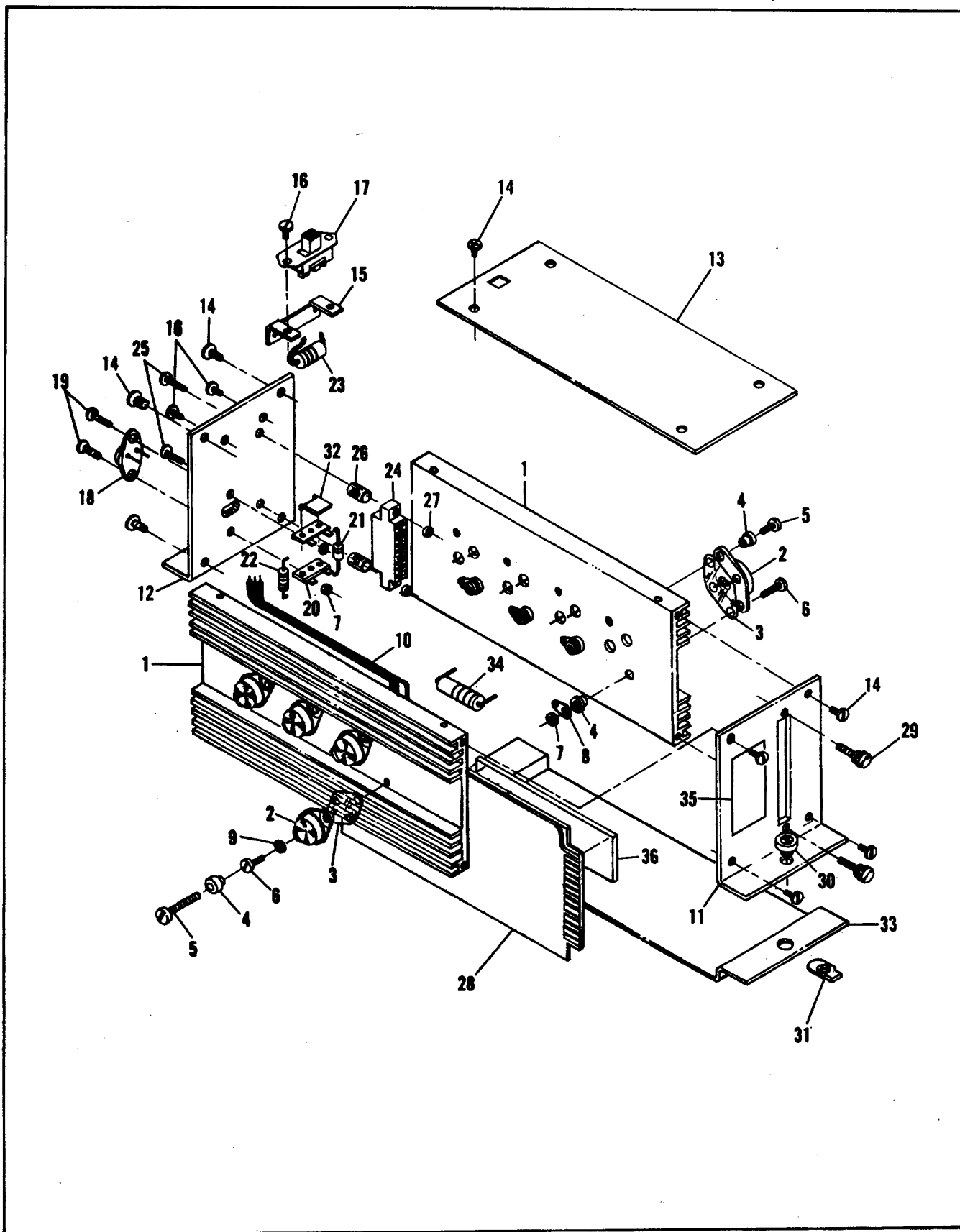

Figure 11-5. 1D395 Amplifier

CENTURY III
1D395 AMPLIFIER

ITEM NO.	PART NO.	DESCRIPTION
-1	27B91	HEAT SINK
-2	48S43	TRANSISTOR
-3	14A46	INSULATOR
-4	4A58	WASHER, Insulator.
-5	3S164	SCREW, 4-40 x 5/16 B. H..
-6	3S212	SCREW, 4-40 x 1/2 B. H.
-7	2S14	NUT, 4-40 Hex
-8	29S56	LUG, Solder, NO. 4
-9	4S40	LOCKWASHER, NO. 4 Int.
-10	30B209	CABLE ASSEMBLY
-11	64A111-1	END PLATE ASSEMBLY
-12	64A110	END PLATE
-13	15B173-1	COVER ASSEMBLY
-14	3S347	SCREW, 6-32 x 5/16 P. H..
-15	7A590	BRACKET
-16	3S48	SCREW, 4-40 x 3/16 B. H..
-17	40S20	SWITCH
-18	48S50	TRANSISTOR
-19	3S175	SCREW, 4-40 x 3/8 B. H.
-20	31S41	STRIP, Terminal
-21	48S38	DIODE.
-22	6R123	RESISTOR, 47 Ohm, 1/2 W
-23	6R36	RESISTOR, 270 Ohm, 2 W
-24	9S78	CONNECTOR
-25	3S42	SCREW, 4-40 x 7/8 B. H..
-26	43A305	SPACER
-27	2S15	NUT, 4-40 Hex
-28	1D397	PRINTED CIRCUIT BOARD ASSEMBLY
-29	3S327	SCREW, Thumb
-30	42S176	FASTENER
-31	64B112	MOUNTING BRACKET
-32	8S14	CAPACITOR, 1 MFD
-33	42S177	RECEPTACLE.
-34	6R106	RESISTOR, 68 Ohm, 2W.
-35	13A265	LABEL
-36	1D511	PRINTED CIRCUIT BOARD (Roll and pitch rate)

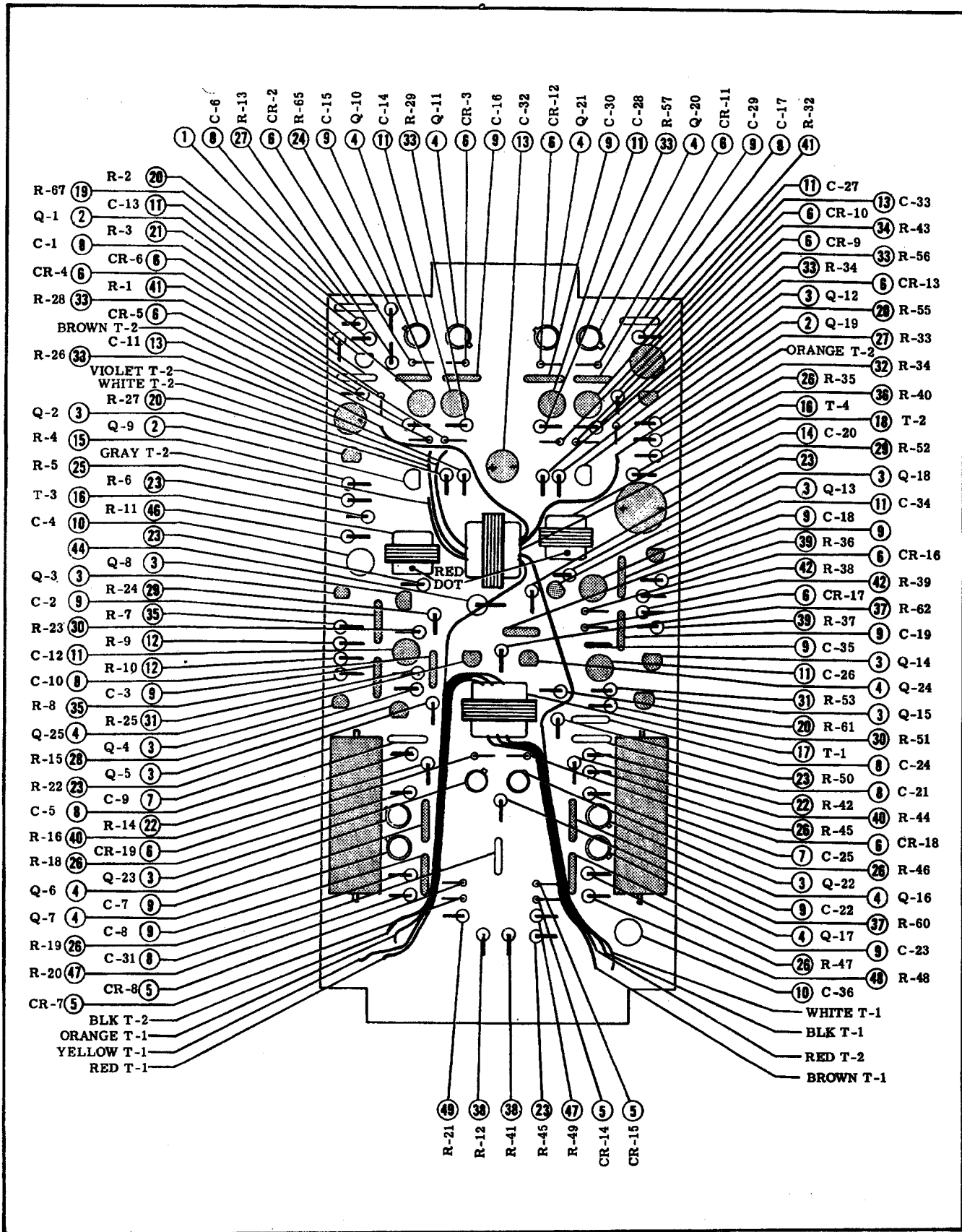

Figure 11-6. 1D397 Printed Circuit Board Assembly

CENTURY III
1D397 (Used in 1D395) PRINTED CIRCUIT
BOARD ASSEMBLY

ITEM NO.	PART NO.	DESCRIPTION
-1	27D90	PRINTED CIRCUIT BOARD
-2	48S48	TRANSISTOR MPS 6519
-3	48S49	TRANSISTOR MPS 6515
-4	48S42	TRANSISTOR 2N3116
-5	48S61	DIODE
-6	48S33	DIODE IN4001
-7	21S64	CAPACITOR, 200 MFG, 5V NP \pm 10%
-8	21S58	CAPACITOR, .22 MFD
-9	8S14	CAPACITOR, 1 MFD
-10	21S66	CAPACITOR, 50 MFD, 5V NP
-11	21A44	CAPACITOR, 5 MFD
-12	6R187	RESISTOR, 1K, 1/2W, 5%
-13	21A45	CAPACITOR, 35 MFD
-14	21S79	CAPACITOR, 100 MFD, 6V NP \pm 10%
-15	6R65	RESISTOR, 220K, 1/2W, 10%
-16	25A23	TRANSFORMER
-17	25B33	TRANSFORMER
-18	25B34	TRANSFORMER
-19	6R71	RESISTOR, 5.6K, 1/2W, 10%
-20	6R72	RESISTOR, 100K, 1/2W, 10%
-21	6R10	RESISTOR, 47K, 1/2W, 10%
-22	6R67	RESISTOR, 150K, 1/2W, 10%
-23	6R118	RESISTOR, 4.7K, 1/2W, 10%
-24	6R180	RESISTOR, 2.7K, 1/2W, 5%
-25	6R46	RESISTOR, 2.7K, 1/2W, 10%
-26	6R31	RESISTOR, 10K, 1/2W, 10%
-27	6R65	RESISTOR, 220K, 1/2W, 10%
-28	6R93	RESISTOR, 820 Ohm, 1/2W, 10%
-29	6R126	RESISTOR, 200K, 1/2W, 10%
-30	6R62	RESISTOR, 22K, 1/2W, 10%
-31	6R125	RESISTOR, 560 Ohm, 1/2W, 10%
-32	6R87	RESISTOR, 1K, 1/2W, 10%
-33	6R23	RESISTOR, 3.3K, 1/2W, 10%
-34	6R89	RESISTOR, 3.9K, 1/2W, 10%
-35	6R188	RESISTOR, 1.5K, 1/2W, 5%
-36	6R168	See Note No. 2.
-37	6R81	RESISTOR, 68 Ohm, 1/2W, 10%
-38	6R131	RESISTOR, 10K, 1/2W, 5%
-39	6R133	RESISTOR, 3.3K, 1/2W, 5%
-40	6R132	RESISTOR, 4.7K, 1/2W, 5%
-41	See Note 1	RESISTOR (Select)
-42	6R189	RESISTOR, 680 Ohm, 1/2W, 5%
-43	10M202	SOLDER
-44	24S94	CHOKE 47
-45	14S151	TRANSISTOR MT6 Pads
-46	See Note 3	RESISTOR, 1/2W, (Select)
-47	6R143	RESISTOR, 1/2W, 15K, 5%
-48	6R157	RESISTOR, 1/2W, 22K, 5%
-49	6R151	RESISTOR, 1/2W, 5.1K, 5%

NOTE 1: Selected resistors to be selected from the following values: (1/2 W, 5% 6R131-10K; 6R140-11K; 6R141-12K; 6R142-13K; 6R143-15K; 6R144-16K; 6R145-18K; 6R98-20K; 6R132-47K; 6R151-5.1K; 6R152-5.6K; 6R153-6.2K; 6R154-6.8K; 6R155-7.5K; 6R150-8.2K; 6R156-9.1K; 6R157-22K; 6R158-24K.

NOTE 2: Item 36 to be selected from resistor values 47K to 180K, 1/2W, 5 and 10%, 6R10-47K,

NOTE 2 (CONT): 6R193-51K; 6R20-56K; 6R194-62K 6R168-68K; 6R169-75K; 6R170-82K; 6R171-91K; 6R72-100K; 6R172-110K; 6R173-120K; 6R174-130K; 6R195-150K; 6R196-160K; 6R79-180K.

NOTE 3: Item 46 to be selected from resistor values 22K to 56K, 1/2W, 5 and 10%, 6R157-22K, 6R62-22K, 6R52-33K, 6R190-36K, 6R90-39K, 6R191-43K, 6R10-47K, 6R193-51K, 6R20-56K.

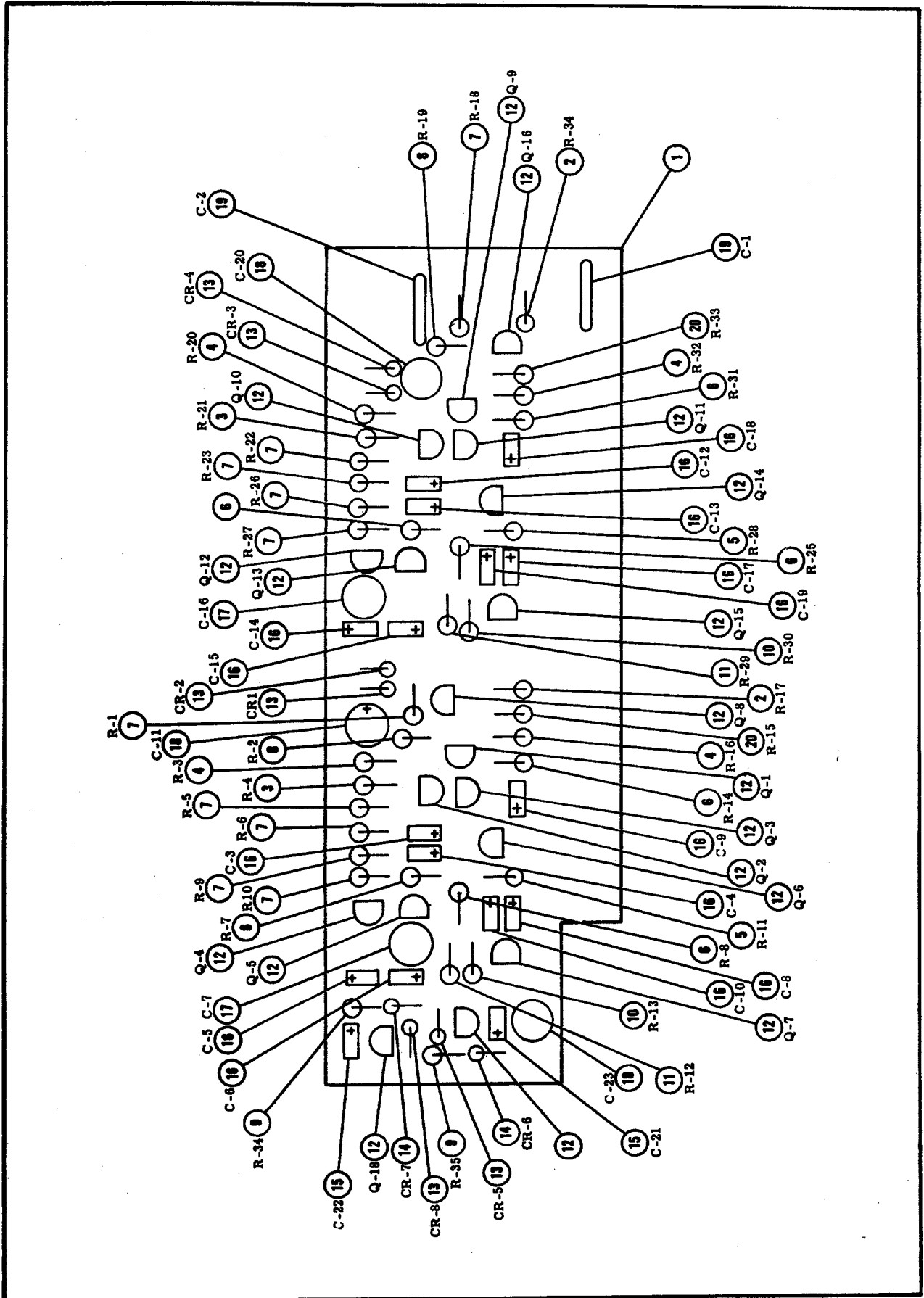

1D511 Printed Circuit Board Assembly

**CENTURY III
1D511 (Used in 1C515 Amp) PRINTED CIRCUIT
BOARD ASSEMBLY**

ITEM NO.	PART NO.	DESCRIPTION
-1	27B128	PRINTED CIRCUIT BOARD
-2	See Note 1	RESISTOR, Sel, 1/2 W
-3	6R180	RESISTOR, 2.7K, 1/2 W, 5%
-4	6R132	RESISTOR, 4.7K, 1/2 W, 5%
-5	6R154	RESISTOR, 6.8K, 1/2 W, 5%
-6	6R131	RESISTOR, 10K, 1/2 W, 5%
-7	6R157	RESISTOR, 22K, 1/2 W, 5%
-8	6R197	RESISTOR, 33K, 1/2 W, 5%
-9	6R168	RESISTOR, 68K, 1/2 W, 5%
-10	6R72	RESISTOR, 100K, 1/2 W, 10%
-11	6R83	RESISTOR, 270K, 1/2 W, 10%
-12	48S49	TRANSISTOR, MPS6515
-13	48S33	DIODE, IN4001
-14	48S16	DIODE, IN34A
-15	21A88	CAPACITOR, 2.2 uf, (Kemet K5R6W20)
-16	21S85	CAPACITOR, 5.6 uf, (Kemet K5R6W20)
-17	21A45	CAPACITOR, 35 uf
-18	21S66	CAPACITOR, 50 uf
-19	8S14	CONDENSER, 1 uf
-20	6R65	RESISTOR, 220K, 1/2 W, 10%

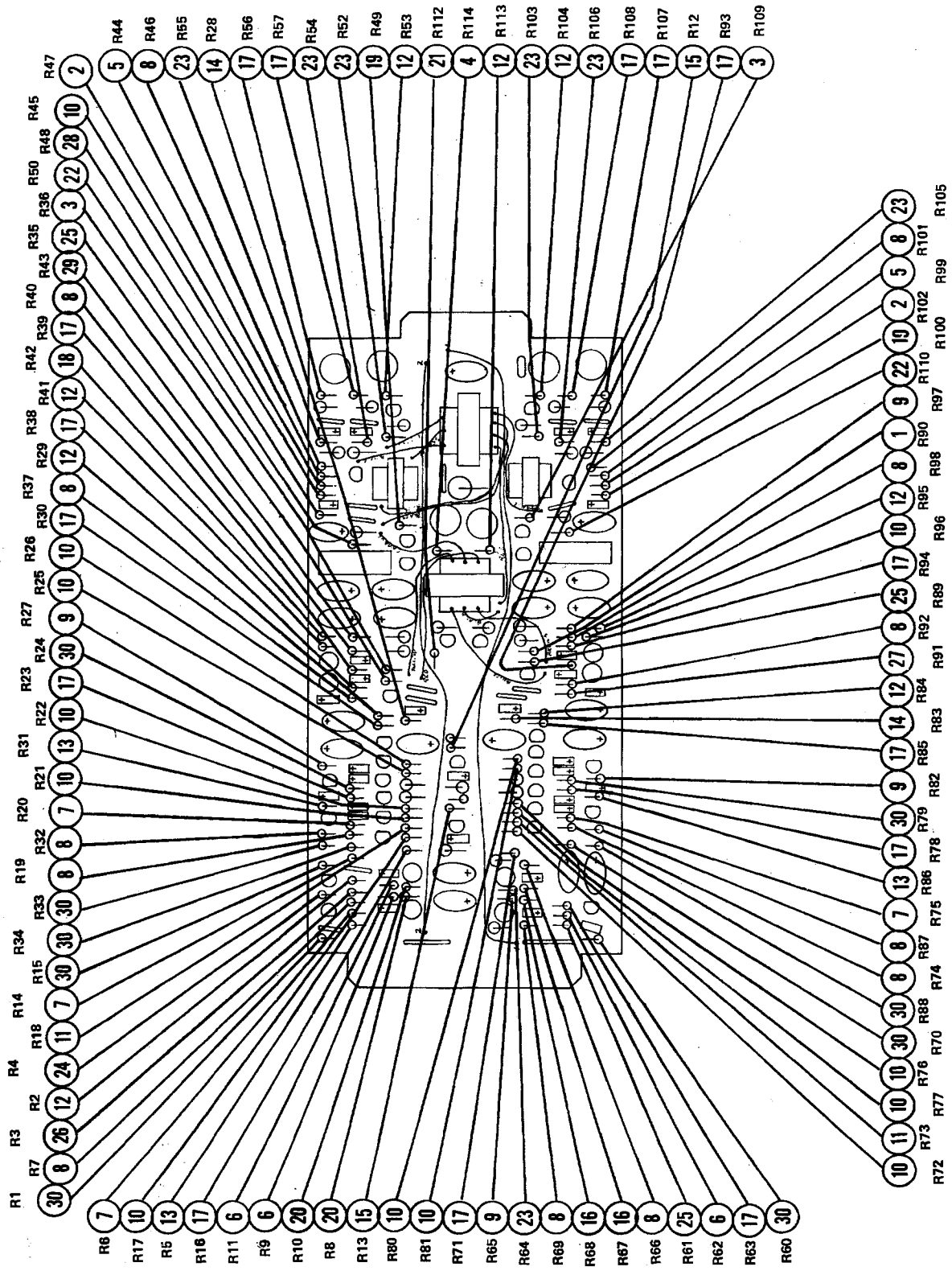

RESISTORS

PRINTED CIRCUIT BOARD ASSEMBLY for 1C515-1 & -2 (AMPLIFIER)

RESISTORS

ITEM NO.	PART NO.	DESCRIPTION
-1	6339224	RESISTOR, 3.9K, ¼W, 2%
-2	6356124	RESISTOR, 560OHM, ¼W, 2%
-3	6382124	RESISTOR, 820 OHM, ¼W, 2%
-4	6368024	RESISTOR, 68 OHM, ¼W, 2%
-5	6320424	RESISTOR, 200K, ¼W, 2%
-6	6310224	RESISTOR, 1K, ¼W, 2%
-7	6327224	RESISTOR, 2.7K, ¼W, 2%
-8	6347224	RESISTOR, 4.7K, ¼W, 2%
-9	6368224	RESISTOR, 6.8K, ¼W, 2%
-10	6322324	RESISTOR, 22K, ¼W, 2%
-11	6333324	RESISTOR, 33K, ¼W, 2%
-12	6310424	RESISTOR, 100K, ¼W, 2%
-13	6322424	RESISTOR, 220K, ¼W, 2%
-14	6327424	RESISTOR, 270K, ¼W, 2%
-15	6368324	RESISTOR, 68K, ¼W, 2%
-16	6368124	RESISTOR, 680 OHM, ¼W, 2%
-17	6310324	RESISTOR, 10K, ¼W, 2%
-18	6315324	RESISTOR, 15K, ¼W, 2%
-19	6312224	RESISTOR, 1.2K, ¼W, 2%
-20	6315224	RESISTOR, 1.5K, ¼W, 2%
-21	6310124	RESISTOR, 100 OHM, ¼W, 2%
-22	6322224	RESISTOR, 2.2K, ¼W, 2%
-23	6333224	RESISTOR, 3.3K, ¼W, 2%
-24	6347324	RESISTOR, 47K, ¼W, 2%
-25	6315424	RESISTOR, 150K, ¼W, 2%
-26	6356224	RESISTOR, 5.6K, ¼W, 2%
-27	6347124	RESISTOR, 470 OHM, ¼W, 2%
-28		
-29	6351224	RESISTOR, 5.1K, ¼W, 2%
-30		RESISTOR, SELECT, ¼W, 2%
-31	11M258	HYSOL PC-18
-32	6312324	RESISTOR, 12K, ¼W, 2%

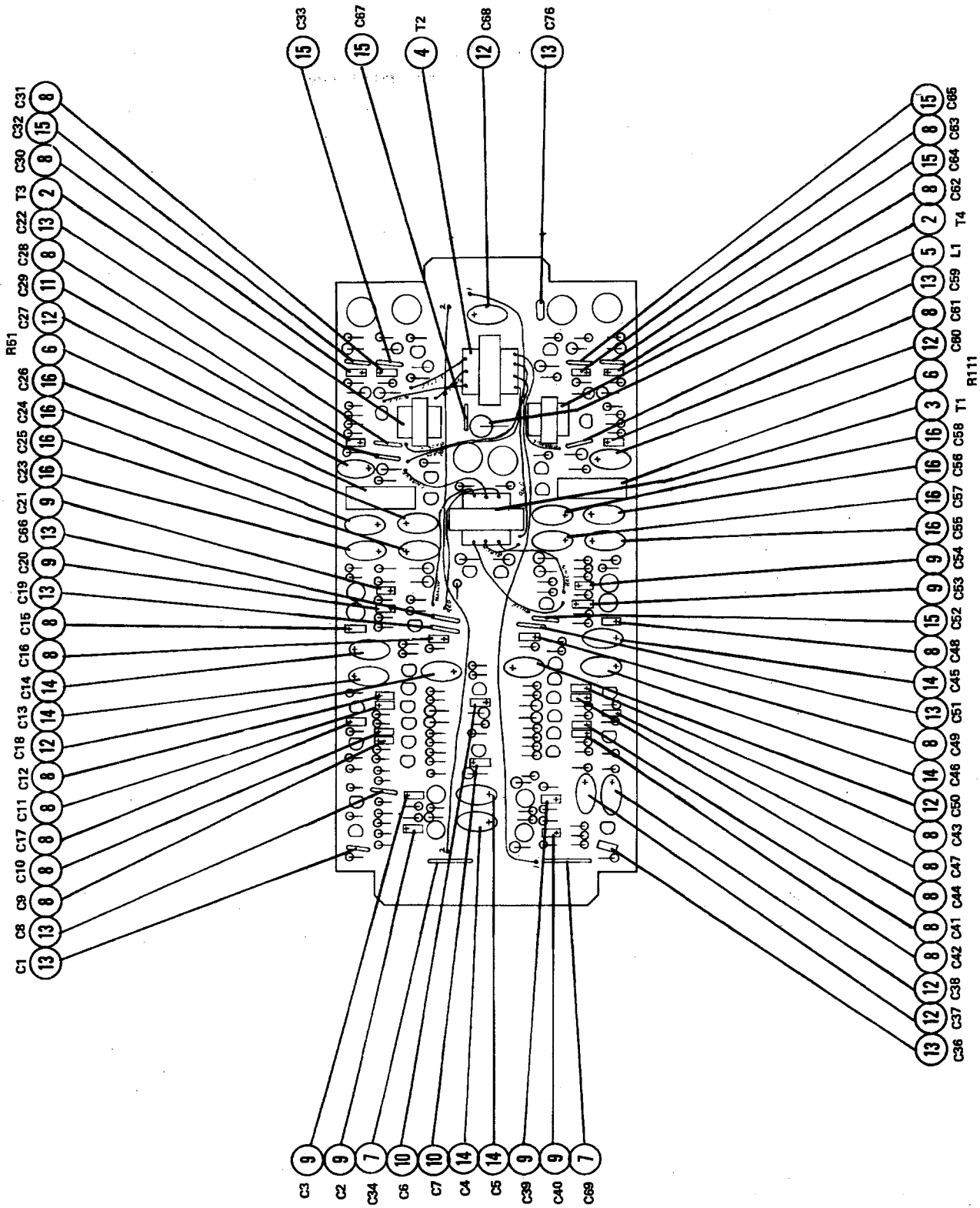

CAPACITORS & TRANSFORMERS

PRINTED CIRCUIT BOARD ASSEMBLY for 1C515 -1 & -2 (AMPLIFIER)

CAPACITORS & TRANSFORMERS

ITEM NO.	PART NO.	DESCRIPTION
-1	27B179-1	PRINTED CIRCUIT BOARD..
-2	25B23	TRANSFORMER
-3	25B33	TRANSFORMER
-4	25B34	TRANSFORMER
-5	24S94	CHOKE, 47 uh.
-6	18S32	POTENTIOMETER, 5K
-7	8S14	CAPACITOR, CERAMIC, 1MFD.
-8	21S85	CAPACITOR, TANTALUM, 5.6 MFD.
-9	21A86	CAPACITOR, TANTALUM, 1MFD.
-10	21A88	CAPACITOR, TANTALUM, 2.2MFD
-11	21S98	CAPACITOR, CERAMIC, .047MFD.
-12	21S139	CAPACITOR, TANTALUM, 47MFD, 20V
-13	21S114	CAPACITOR, CERAMIC, .22MFD
-14	21S116	CAPACITOR, TANTALUM, 100MFD.
-15	21S118	CAPACITOR, CERAMIC, 1MFD
-16	21S126	CAPACITOR, TANDALUM, 220MFD
-17	10M53	WIRE , NO. 20 WHITE
-18	21S101	CAPACITOR, CERAMIC, 330PF
-19	13A601	PLACARD, R-THLD
-20	13A600	PLACARD, P-THLD
-21	11M49	WIRE, NO. 22 AWG, WHITE, 1 1/2" LONG
-22	21S155	CAP. 200 MFD, 30V. 15% NON-POLAR TANTALUM

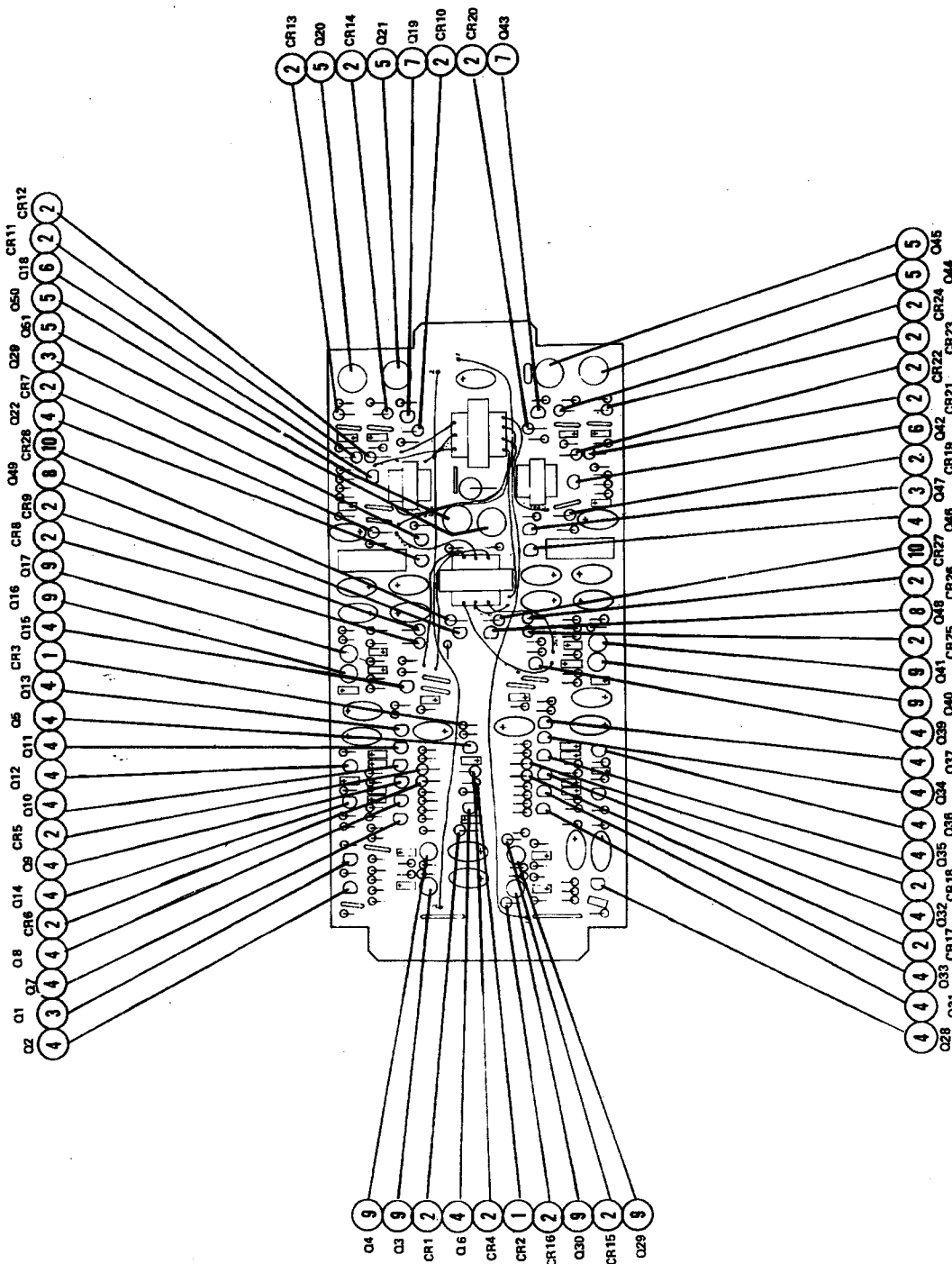

TRANSISTORS & DIODES

1C515-1 & 2 AMPLIFIER CIRCUIT BOARD

PRINTED CIRCUIT BOARD ASSEMBLY for 1C515-1 & -2 (AMPLIFIER)

TRANSISTORS & DIODES

ITEM NO.	PART NO.	DESCRIPTION
-1	48S16	DIODE, IN34A
-2	48S33	DIODE, IN4001
-3	48S48	TRANSISTOR, MPS 6519
-4	48S49	TRANSISTOR, MPS 6519
-5	48S62	TRANSISTOR, 2N3116, 60V
-6	48S63	TRANSISTOR, 2N4410
-7	48S64	TRANSISTOR, 2N4403
-8	48S69	TRANSISTOR, 2N4401
-9	48S42	TRANSISTOR, 2N3116
-10	48S98	DIODE, IN4933

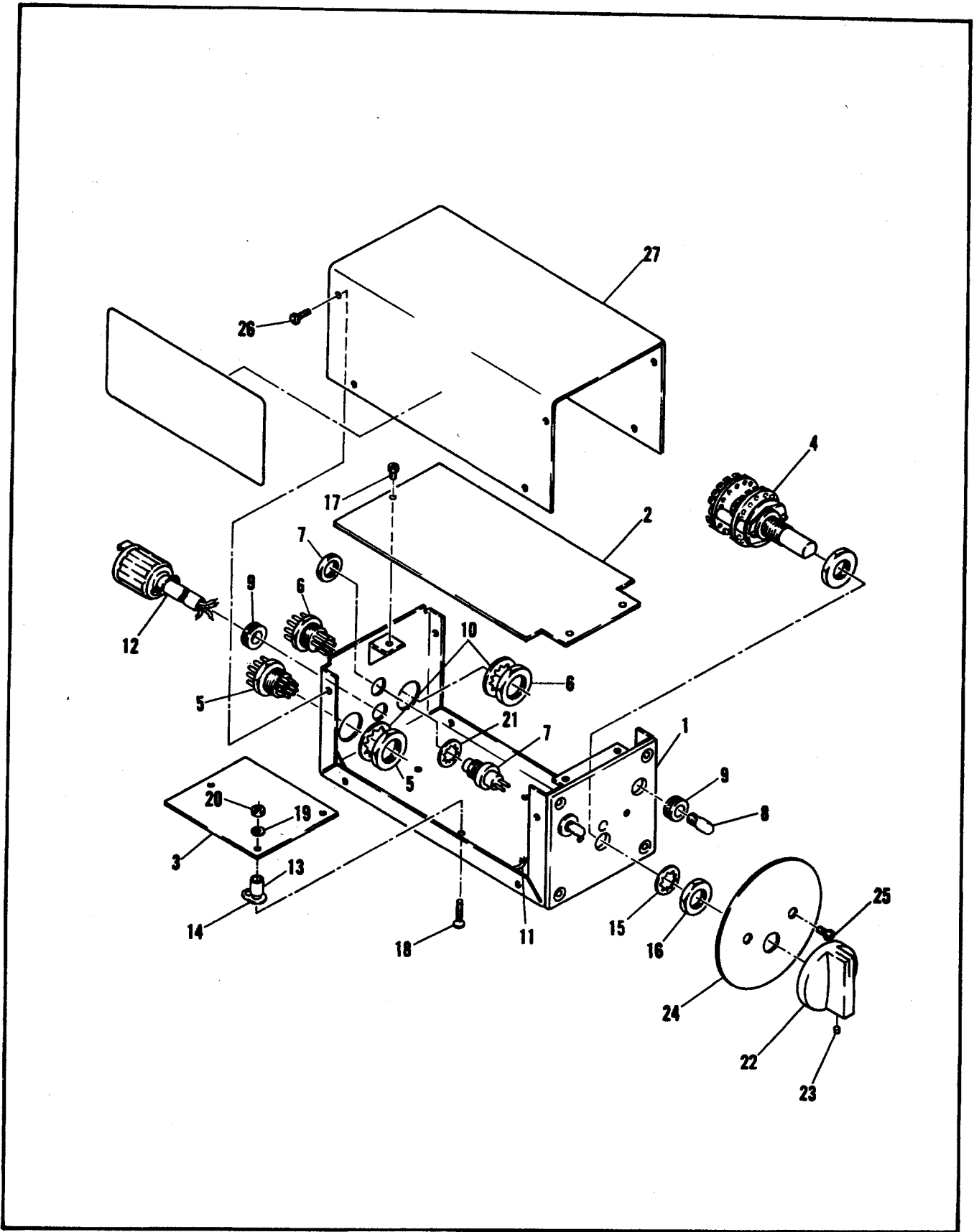

1C388 Radio Coupler

1C388 - RADIO COUPLER

ITEM NO.	PART NO.	DESCRIPTION
-1	1B410	CHASSIS ASSY.
-2	1C412	PRINTED CIRCUIT BOARD ASSEMBLY
-3	1B413	PRINTED CIRCUIT BOARD ASSEMBLY..
-4	1B411	SWITCH ASSEMBLY
-5	28S53	CONNECTOR (9 pin)
-6	28S50	CONNECTOR (7 pin)
-7	40S24	SWITCH
-8	65S32	LIGHT BULB (28 V)
-9	5S59	GROMMET
-10	4S167	LOCKWASHER (1/2 Int.)
-11	30C216	CABLE ASSY. (Int.)
-12	30B217	CABLE ASSY. (Ext.)
-13	43A320	STANDOFF
-14	29S21	GROUND LUG.
-15	4S167	LOCKWASHER (3/8 Int.)
-16	2S60	NUT 3/8 - 32 Hex
-17	3S48	SCREW 4-40 x 3/16 B. H.
-18	3S384	SCREW 4-40 x 7/16 B. H.
-19	4S40	LOCKWASHER (No. 4 Int.)
-20	2S14	NUT 4-40 Hex
-21	4S117	LOCKWASHER (3/8 Int.)
-22	36A98	KNOB
-23	3S272	SET SCREW 8-32 x 1/2
-24	13A241	FACE PLATE
-25	3S289	SCREW 2-56 x 5/16 F. H.
-26	3S61	SCREW 2-56 x 1/8 B. H.
-27	15B189	COVER

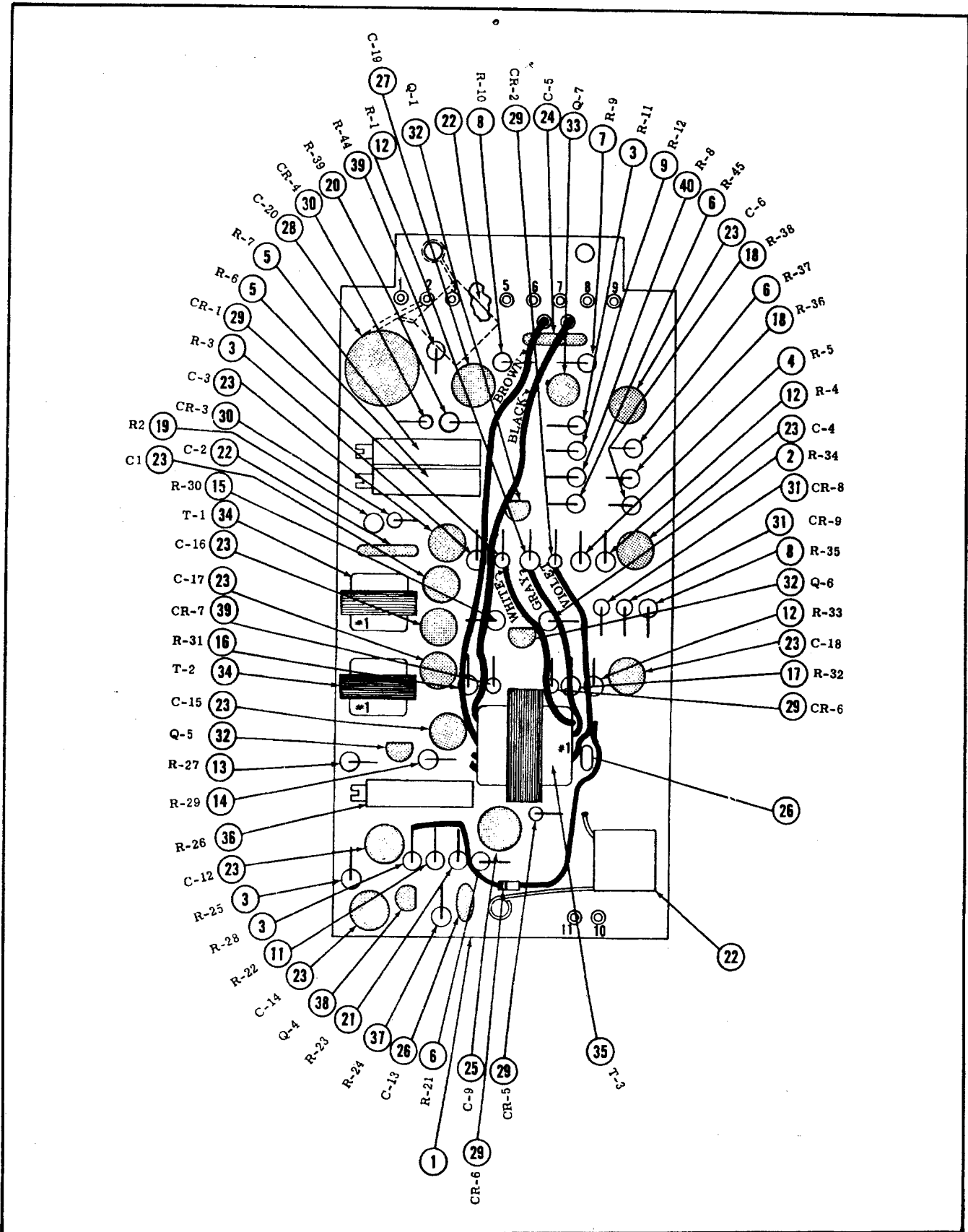

1C412 Radio Coupler Printed Circuit Board

1C412 - RADIO COUPLER PRINTED CIRCUIT BOARD

ITEM NO.	PART NO.	DESCRIPTION
-1	27B100	PRINTED CIRCUIT BOARD
-2	6R20	RESISTOR, 56K, 1/2W, 10%
-3	6R46	RESISTOR, 2.7K, 1/2W, 10%
-4	6R23	RESISTOR, 3.3K, 1/2W, 10%
-5	18S20	POTENTIOMETER, 20K.
-6	6R31	RESISTOR, 10K, 1/2W, 10%
-7	6R24	RESISTOR, 330 Ohm, 1/2W, 10%
-8	6R59	RESISTOR, 6.8K, 1/2W, 10%
-9	6R58	RESISTOR, 12K, 1/2W, 10%
-10	6R70	RESISTOR, 2.2K, 1/2W, 10%
-11	6R72	RESISTOR, 100K, 1/2W, 10%.
-12	A/R	RESISTOR, Sel-See Note No. 1
-13	6R89	RESISTOR, 3.9K, 1/2W, 10%
-14	6R92	RESISTOR, 680 Ohm, 1/2W, 10%
-15	6R87	RESISTOR, 1K, 1/2W, 10%.
-16	6R73	RESISTOR, 8.2K, 1/2W, 10%
-17	6R122	RESISTOR, 9.1K, 1/2W, 10%
-18	6R146	RESISTOR, 120K, 1/2W, 10%.
-19	6R84	RESISTOR, 68K, 1/2W, 10%
-20	6R52	RESISTOR, 33K, 1/2W, 10%
-21	6R57	RESISTOR, 27K, 1/2W, 10%
-22	21S58	CAPACITOR, 22 uf.
-23	21A44	CAPACITOR, 5 uf
-24	21S2	CAPACITOR, .01 uf
-25	21A45	CAPACITOR, 35 uf.
-26	21S12	CAPACITOR, .001 uf
-27	21S66	CAPACITOR, .50 uf, NP.
-28	21S67	CAPACITOR, 200 uf, NP
-29	48S33	DIODE, IN4001
-30	48S61	DIODE, SR1741
-31	48S52	DIODE, IN4735-B
-32	48S48	TRANSISTOR, MPS 6519
-33	48S36	TRANSISTOR, SM 2140.
-34	25A23	TRANSFORMER
-35	25B34	TRANSFORMER
-36	18S23	POTENTIOMETER, 100 Ohm.
-37	6R77	RESISTOR, 100 Ohm, 1/2W, 10%
-38	48S49	TRANSISTOR, MPS 6515
-39	6R67	RESISTOR, 150K, 1/2W, 10%.
-40	A/R	RESISTOR, Select (Select Note No. 1)

NOTE 1: Item No. 12 to be selected from the following values for R-1, R-4, R-33.

<p>Select (R-1) from below:</p> <table border="0"> <tr> <th style="text-align: left;">Part No.</th> <th style="text-align: left;">Resistor</th> </tr> <tr> <td>6R160</td> <td>39 Ohms + 5%, 1/2W</td> </tr> <tr> <td>6R161</td> <td>43 Ohms ± 5%, 1/2W</td> </tr> <tr> <td>6R162</td> <td>47 Ohms ± 5%, 1/2W</td> </tr> <tr> <td>6R163</td> <td>51 Ohms ± 5%, 1/2W</td> </tr> <tr> <td>6R164</td> <td>56 Ohms ± 5%, 1/2W</td> </tr> <tr> <td>6R165</td> <td>62 Ohms ± 5%, 1/2W</td> </tr> <tr> <td>6R166</td> <td>68 Ohms ± 5%, 1/2W</td> </tr> </table>	Part No.	Resistor	6R160	39 Ohms + 5%, 1/2W	6R161	43 Ohms ± 5%, 1/2W	6R162	47 Ohms ± 5%, 1/2W	6R163	51 Ohms ± 5%, 1/2W	6R164	56 Ohms ± 5%, 1/2W	6R165	62 Ohms ± 5%, 1/2W	6R166	68 Ohms ± 5%, 1/2W	<p>Select (R-4) From: ± 5% Resistors 4.7 to 20K, 1/2W.</p> <p>Select (R-8) From: 10K to 20K 1/2W, ± 5% resistors.</p> <p>Select (R-33) From: Approximately 27K to 1/2W, ± 10% resistors.</p>
Part No.	Resistor																
6R160	39 Ohms + 5%, 1/2W																
6R161	43 Ohms ± 5%, 1/2W																
6R162	47 Ohms ± 5%, 1/2W																
6R163	51 Ohms ± 5%, 1/2W																
6R164	56 Ohms ± 5%, 1/2W																
6R165	62 Ohms ± 5%, 1/2W																
6R166	68 Ohms ± 5%, 1/2W																

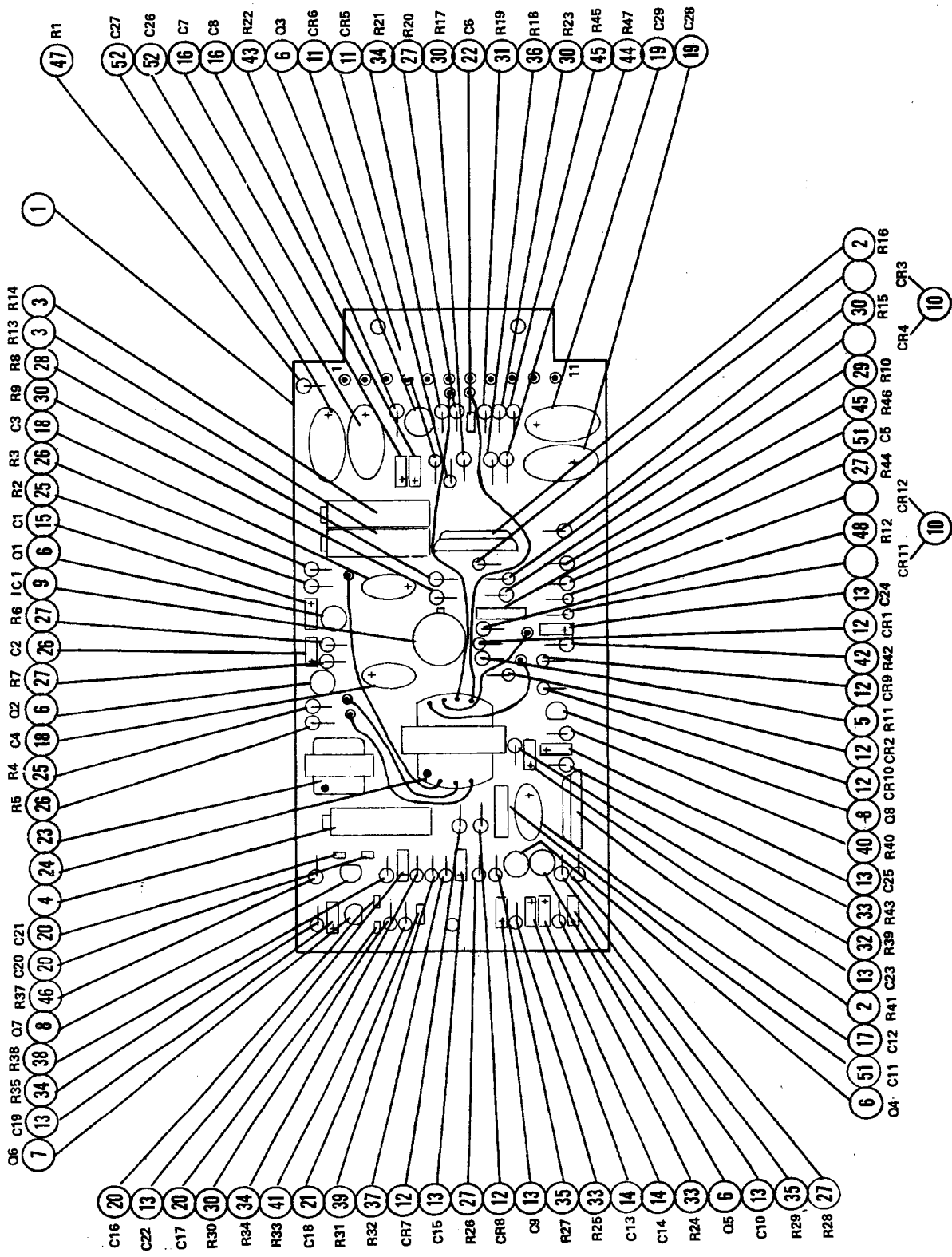

1C388 PRINTED CIRCUIT BOARD SERIAL NO'S 6000 AND ABOVE

PRINTED CIRCUIT BOARD ASSEMBLY 1C388, 1C388M, 1C388MC & 1C388-2

RADIO COUPLER, SN 6000 & Above

ITEM NO.	PART NO.	DESCRIPTION
-1	27C181	PRINTED CIRCUIT BOARD
-2	18S43	POTENTIOMETER, 10K, $\pm 30\%$
-3	18S31	POTENTIOMETER, 20K
-4	18S29	POTENTIOMETER, 100
-5	6R267	RESISTOR, 3.9K, $\frac{1}{4}W$, 5%
-6	48S42	TRANSISTOR, 2N3116
-7	48S49	TRANSISTOR, MPS 6515
-8	48S48	TRANSISTOR, MPS 6519
-9	48S89	INTEGRATED CIRCUIT, MC 1741 CG
-10	48S52-1	DIODE, ENER, IN 4735A MATCHED PAIR
-11	48S61	DIODE, SR 1741
-12	48S33	DIODE, IN 4001
-13	21S85	CAPACITOR, 5.6 UF, 20V, 20%, KEMET
-14	21A87	CAPACITOR, .22UF, 35V, 20%, KEMET
-15	21A86	CAPACITOR, 1.0 UF, 35V, 20%, KEMET
-16	21A117	CAPACITOR, 10 UF, 10V, KEMET
-17	21S139	CAPACITOR, 47 UF, 20V, KEMET
-18	21S135	CAPACITOR, 22 UF, 25V, KEMET
-19	21S116	CAPACITOR, 100 UF, 20V, KEMET
-20	21S101	CAPACITOR, 330 PF
-21	21S97	CAPACITOR, .001 UF, ERIE
-22	21S95	CAPACITOR, .001 UF, ERIE
-23	25B23	TRANSFORMER
-24	25B34	TRANSFORMER
-25	6312224	RESISTOR, 1.2K, $\frac{1}{4}W$, 2%
-26	6347224	RESISTOR, 4.7K, $\frac{1}{4}W$, 2%
-27	6368224	RESISTOR, 6.8K, $\frac{1}{4}W$, 2%
-28	6322424	RESISTOR, 220K, $\frac{1}{4}W$, 2%
-29	6322323	RESISTOR, 22K, $\frac{1}{4}W$, 2%
-30	6310324	RESISTOR, 10K, $\frac{1}{4}W$, 2%
-31	6333124	RESISTOR, 330 OHM, $\frac{1}{4}W$, 2%
-32	6310224	RESISTOR, 1K, $\frac{1}{4}W$, 2%
-33	6333224	RESISTOR, 3.3K, $\frac{1}{4}W$, 2%
-34	6327224	RESISTOR, 2.7K, $\frac{1}{4}W$, 2%
-35	6322224	RESISTOR, 2.2K, $\frac{1}{4}W$, 2%
-36	6333324	RESISTOR, 33K, $\frac{1}{4}W$, 2%
-37	6327324	RESISTOR, 27K, $\frac{1}{4}W$, 2%
-38	6368124	RESISTOR, 680 OHM, $\frac{1}{4}W$, 2%
-39	6310424	RESISTOR, 100K, $\frac{1}{4}W$, 2%
-40	6368324	RESISTOR, 68K, $\frac{1}{4}W$, 2%
-41	6310124	RESISTOR, 100 OHM, $\frac{1}{4}W$, 2%
-42	6382224	RESISTOR, 8.2K, $\frac{1}{4}W$, 2%
-43	6312324	RESISTOR, 12K, $\frac{1}{4}W$, 2%
-44	6315424	RESISTOR, 150K, $\frac{1}{4}W$, 2%
-45	6312424	RESISTOR, 120K, $\frac{1}{4}W$, 2%
-46		RESISTOR, SELECT 2.0K - 4.3K, $\frac{1}{4}W$, 2%
-47		RESISTOR, SELECT 10K NOM., $\frac{1}{4}W$, 2%
-48	6351224	RESISTOR, 5.1K, $\frac{1}{4}W$, 2%
-49	11M56	M. F. R. VARNISH
-50	10M85	SOLDER
-51	21S114	CAPACITOR, .22 UF, 50V, 20%, ERIE
-52	21S126	CAPACITOR, 220 UF, 10V, KEMET

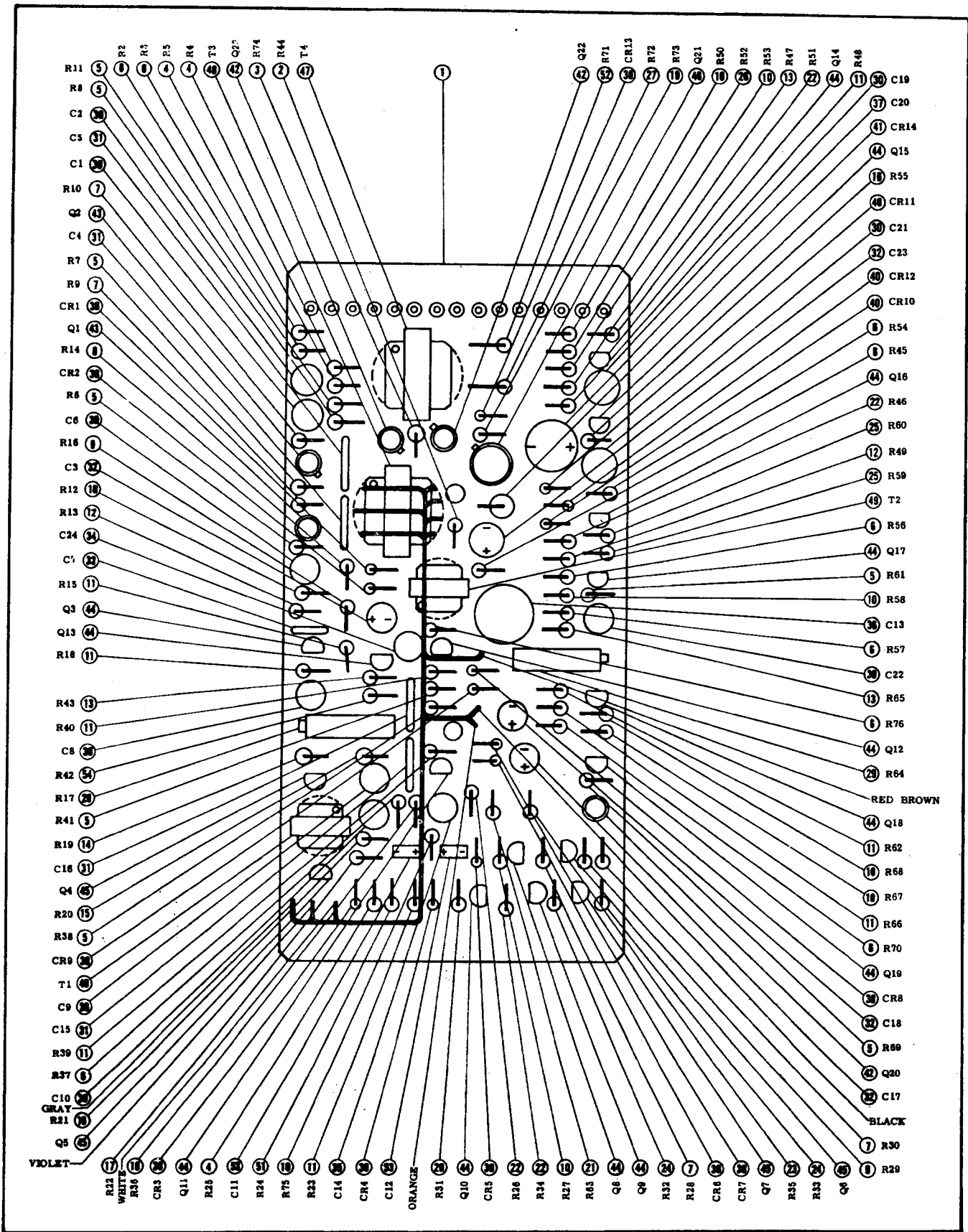

79D41 Printed Circuit Board Assembly

**79D41 GLIDE SLOPE COUPLER
PRINTED CIRCUIT BOARD**

ITEM NO.	PART NO.	DESCRIPTION
-1	27D122	PRINTED CIRCUIT BOARD
-2	6R199	RESISTOR, 200 ohm, 1/2W, 5%
-3	6R198	RESISTOR, 30 ohm, 1/2W, 5%
-4	6R133	RESISTOR, 3.3K, 1/2W, 5%
-5	6R154	RESISTOR, 6.8K, 1/2W, 5%
-6	6R132	RESISTOR, 4.7K, 1/2W, 5%
-7	6R192	RESISTOR, 2.2K, 1/2W, 5%
-8	6R10	RESISTOR, 47K, 1/2W, 10%
-9	6R77	RESISTOR, 100 ohm, 1/2W, 10%
-10	6R131	RESISTOR, 10K, 1/2W, 5%
-11	6R180	RESISTOR, 2.7K, 1/2W, 5%
-12	6R57	RESISTOR, 27K, 1/2W, 10%
-13	6R72	RESISTOR, 100K, 1/2W, 10%
-14	6R89	RESISTOR, 3.9K, 1/2W, 10%
-15	6R92	RESISTOR, 680 ohm, 1/2W, 10%
-16	6R87	RESISTOR, 1K, 1/2W, 10%
-17	6R20	RESISTOR, 56K, 1/2W, 10%
-18	6R195	RESISTOR, 150K, 1/2W, 5%
-19	6R82	RESISTOR, 150 ohm, 1/2W, 10%
-20	6R88	RESISTOR, 470 ohm, 1/2W, 10%
-21	6R73	RESISTOR, 8.2K, 1/2W, 10%
-22	6R157	RESISTOR, 22K, 1/2W, 5%
-23	6R65	RESISTOR, 220K, 1/2W, 10%
-24	6R34	RESISTOR, 2K, 1/2W, 5%
-25	6R143	RESISTOR, 15K, 1/2W, 5%
-26	6R91	RESISTOR, 1.2K, 1/2W, 10%
-27	6R201	RESISTOR, Wire wound, 150 ohm, 3W, 5%
-28	18S29	POTENTIOMETER, 100 ohm, 1/2W, 20 turn
-29	18S31	POTENTIOMETER, 20K, 1/2W, 20 turn
-30	21A44	CAPACITOR, 5 MFD, NP
-31	21S58	CAPACITOR, .22 MFD, NP
-32	21A45	CAPACITOR, 35 MFD @ 15V, R
-33	21S12	CAPACITOR, .001 MFD, NP
-34	21S84	CAPACITOR, 25 MFD, NP 10%, 15V
-35	21S83	CAPACITOR, 2 MFD, NP, 10%
-36	21S80	CAPACITOR, 200 MFD, NP, 10%
-37	21S82	CAPACITOR, 200 MFD, P, 10%
-38	48S33	DIODE, IN4001
-39	48S61	DIODE, SR1741, Motorola
-40	48S51-H	DIODE, SR1553, Motorola
-41	48S38	DIODE, Zenner, 11V, IN962B
-42	48S42	TRANSISTOR, 2N3116
-43	48S36	TRANSISTOR, SM2140
-44	48S49	TRANSISTOR, MPS6515
-45	48S48	TRANSISTOR, MPS6519
-46	48S62	TRANSISTOR
-47	25B39	TRANSFORMER
-48	25B34	TRANSFORMER
-49	25A23	TRANSFORMER
-50	10M85	SOLDER
-51	See Note 1	RESISTOR, Selected, 1/2W
-52	6R200	RESISTOR, Wire wound, 100 ohm, 2W, 5%
-53	21S85	CAPACITOR, Tantalum, 5.6 MFD, ±20%, 15WV
-54	See Note 2	RESISTOR, Selected, 1/2W

Note 1: R-24 to be selected from 4.7K to 56K (For detector centering)
Note 2: R-42 to be selected for correct output. Range to be from 2K to 5.1K 1/2 Watt resistor.

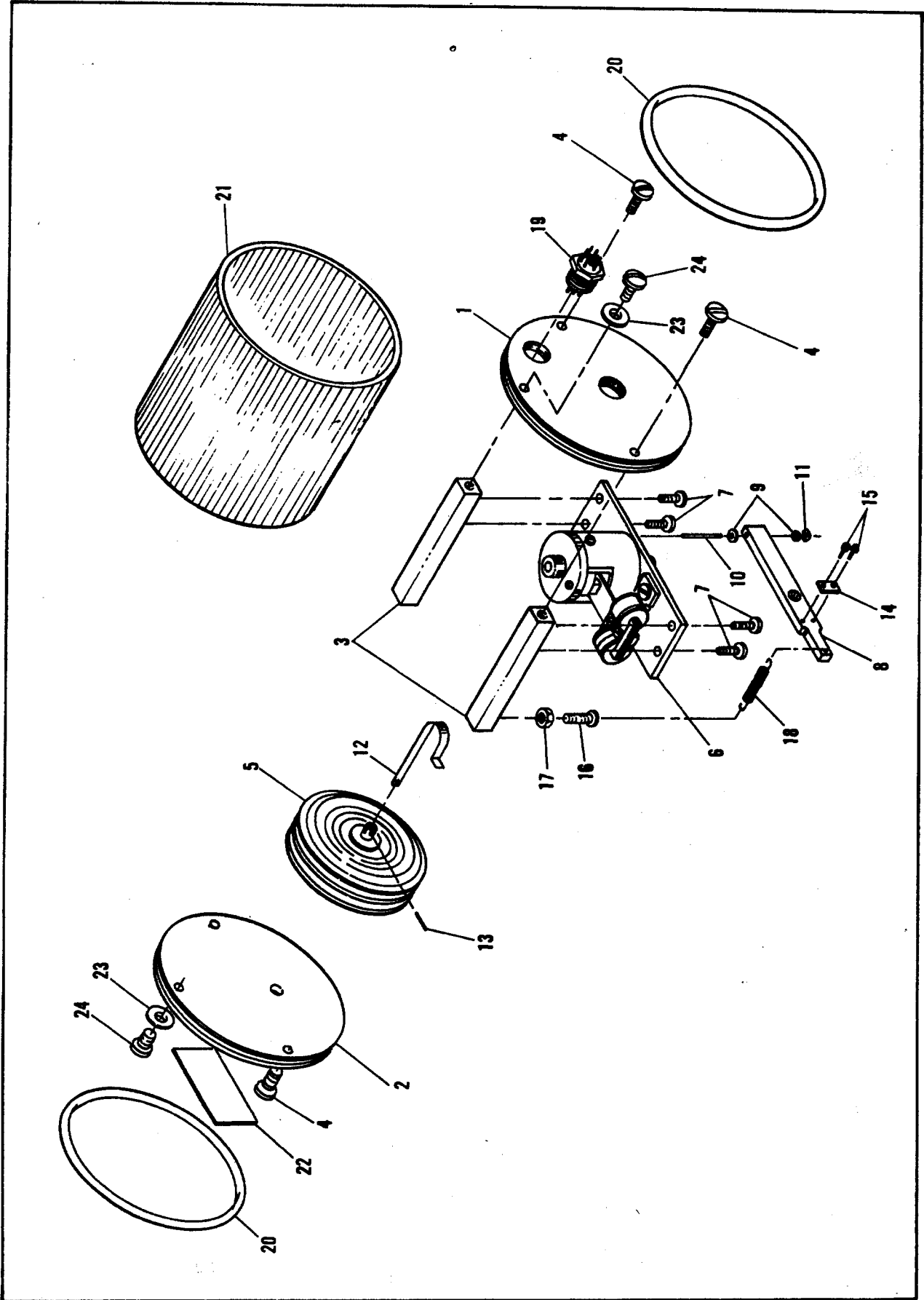

1C407 Altitude Hold

**ALTITUDE HOLD
1C407**

ITEM NO.	PART NO.	DESCRIPTION
-1	64A119	PLATE, Front
-2	64A95	PLATE, Back
-3	7A392	BAR, Support
-4	3S228	SCREW, 6-32 x 1/2 B. H..
-5	15A147-1	BELLOWS
-6	1B417	CLUTCH ASSEMBLY
-7	3S164	SCREW, 4-40 x 5/16 B. H.
-8	45A42	LEVER
-9	43A222	SPACER
-10	47A188	SHAFT
-11	42S161	RETAINER VALUES NO. 53-5-6
-12	45A44	TAPE, Linkage
-13	10M39	WIRE, Bus No. 22
-14	42A159	BLOCK, Clamping
-15	3S357	SCREW, 1-72 x 3/16 B. H.
-16	3S109	SCREW, 2-56 x 1/2 B. H..
-17	2S46	NUT, 2-56 Hex
-18	41A84	SPRING
-19	28S52	CONNECTOR, 5 Pin with locking clip.
-20	4S139	O-RING
-21	15A138	COVER
-22	13A265	NAMEPLATE
-23	4S144	WASHER.
-24	3S38	SCREW, 6-32 x 3/16 B. H.

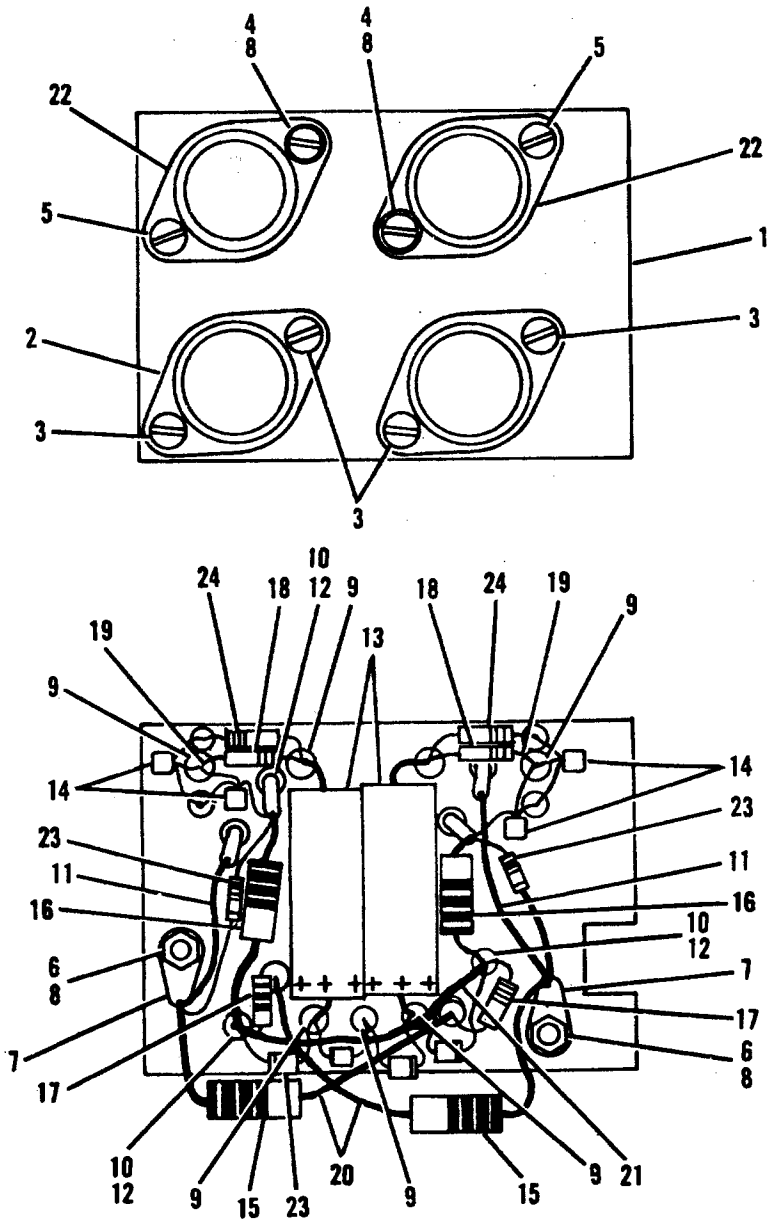

Amplifier Assembly

1B369-1 - TRIM AMPLIFIER

ITEM NO.	PART NO.	DESCRIPTION
-1	27B75-1	CHASSIS, Amplifier
-2	48S23	TRANSISTOR
-3	3S164	SCREW, 4-40 x 5/16
-4	3S175	SCREW, 4-40 x 3/8
-5	3S110	SCREW, 4-40 x 5/8
-6	2S14	NUT, 4-40 Hex
-7	29S56	LUG, Solder, No. 4 locking
-8	4A58	WASHER, Shoulder
-9	29A1B	STANDOFF
-10	29S20	TERMINAL
-11	30A141	WIRE ASSEMBLY
-12	11M86	SLEEVING
-13	21S43	CAPACITOR, 354 MFD
-14	48S48	TRANSISTOR
-15	6R123	RESISTOR, 270 ohm, 2 W
-16	6R103	RESISTOR, 470 ohm, 1 W
-17	6R27	RESISTOR, 10 ohm, 1/2W
-18	6R23	RESISTOR 3.3K, 1/2W
-19	11S46	SLEEVING
-20	11M87	SLEEVING
-21	10M45	WIRE, No. 22 Red
-22	14A46	INSULATOR
-23	48S33	DIODE
-24	6R94	RESISTOR, 180 ohm, 1/2W, 10%

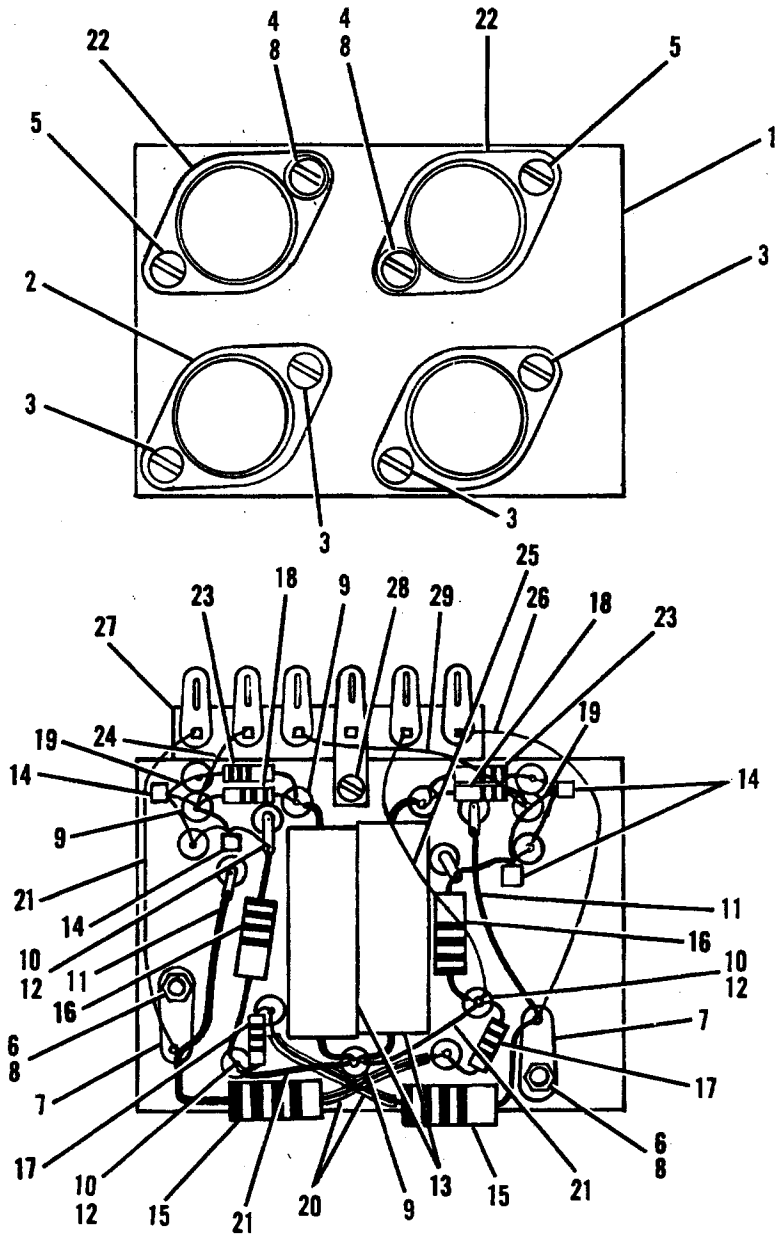

Amplifier Assembly

1B346 - TRIM AMPLIFIER

ITEM NO.	PART NO.	DESCRIPTION
-1	27B75	CHASSIS, Amplifier
-2	48S23	TRANSISTOR
-3	3S164	SCREW, 4-40 x 5/16
-4	3S175	SCREW, 4-40 x 3/8
-5	3S110	SCREW, 4-40 x 5/8
-6	2S14	NUT, Hex, 4-40
-7	29S56	LUG, Solder, No. 4 Locking
-8	4A58	WASHER, Shoulder
-9	29S18	STANDOFF
-10	29S20	TERMINAL
-11	30A141	WIRE ASSEMBLY
-12	11M86	TUBING
-13	21S43	CAPACITOR, 354 MFD, 25V
-14	48S48	TRANSISTOR
-15	6R106	RESISTOR, 68 ohm, 2W
-16	6R107	RESISTOR, 15 ohm, 1W
-17	6R27	RESISTOR, 10 ohm, 1/2W
-18	6R23	RESISTOR, 3.3K, 1/2W
-19	11S46	SLEEVING
-20	11M87	SLEEVING
-21	10M45	WIRE, No. 22 Red
-22	14A46	INSULATOR
-23	6R94	RESISTOR, 180 ohm, 1/2W, 10%
-24	10M42	WIRE, No. 22 Yellow
-25	10M43	WIRE, No. 22 Gray
-26	10M41	WIRE, No. 22 Violet
-27	31A35	TERMINAL STRIP
-28	3S38	SCREW, 6-32 x 3/16
-29	10M46	WIRE, No. 22 Orange

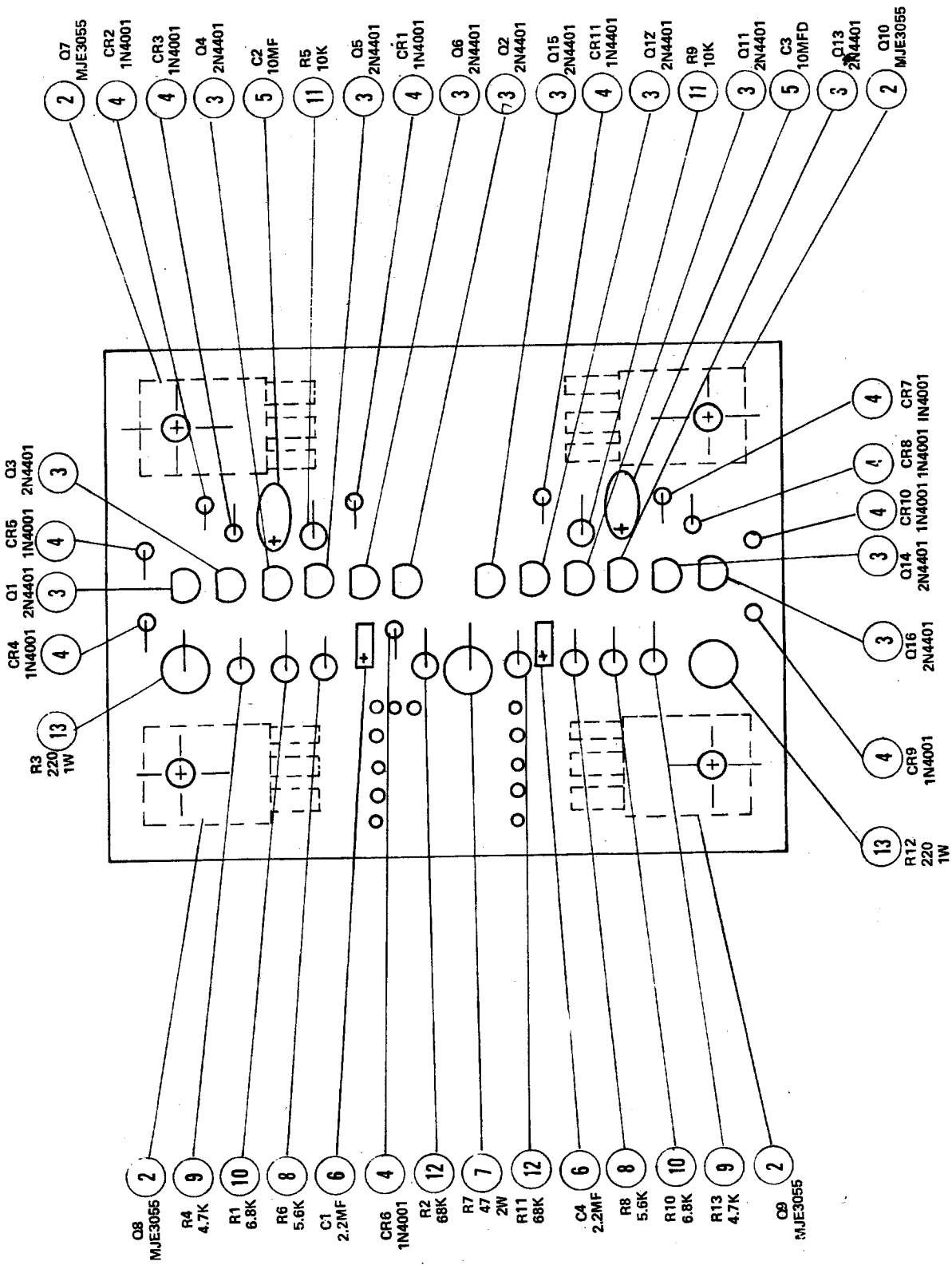

TRIM AMPLIFIER 1C646 P. C. B.

**PRINTED CIRCUIT BOARD ASSEMBLY (14V) PITCH TRIM AMPLIFIER - 1C646,
DUAL SENSOR**

ITEM NO.	PART NO.	DESCRIPTION
-1	27D190	PRINTED CIRCUIT BOARD
-2	48S73	TRANSISTOR, MJE 3055
-3	48S69	TRANSISTOR, 2N4401
-4	48S33	DIODE, IN4001
-5	21S138	CAPACITOR, 33 MF, 20V., TANTALUM
-6	21A88	CAPACITOR, 2.2 'F, 35V, TANTALUM.
-7	6R75	RESISTOR, .47 , 2W, W. W.
-8	6356224	RESISTOR, 5.6K, 1/4W, 2%
-9	6347224	RESISTOR, 4.7K, 1/4W, 2%
-10	6368224	RESISTOR, 6.8K, 1/4W, 2%
-11	6310324	RESISTOR, 10K, 1/4W, 2%
-12	6368324	RESISTOR, 68K, 1/4W, 2%
-13	6R147	RESISTOR, 220 , 1W, CARBON
-14	11M258	HYSOL, PC 18.

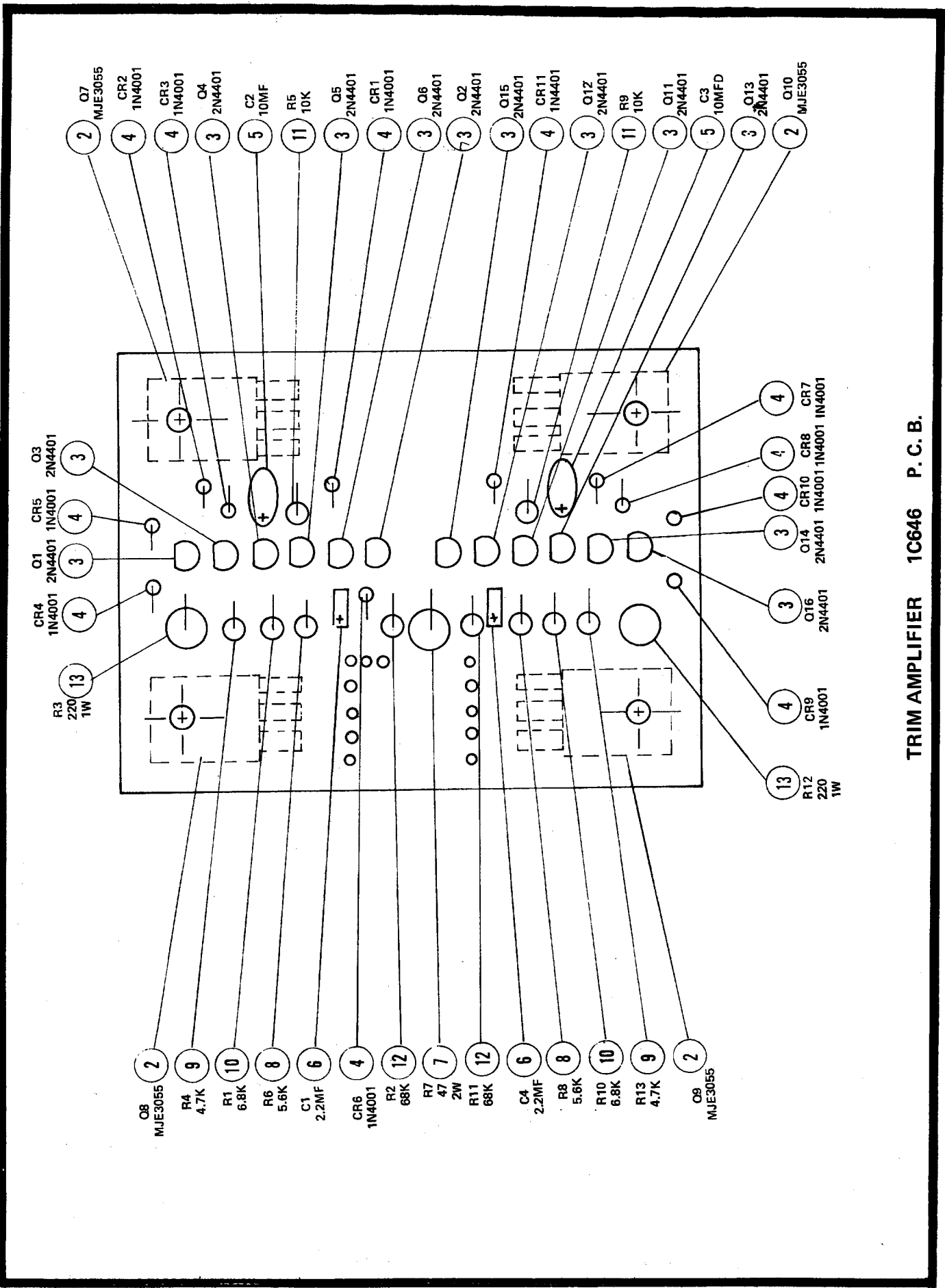

TRIM AMPLIFIER 1C646 P. C. B.

PITCH TRIM AMPLIFIER DUAL SENSOR - 1C646

ITEM NO.	PART NO.	DESCRIPTION
-1	27D190	PRINTED CIRCUIT BOARD
-2	48S73	TRANSISTOR, MJE 3055
-3	48S69	TRANSISTOR, 2N4401
-4	48S33	DIODE, IN4001
-5	21S151	CAPACITOR, 10MF, 35V, TANTALUM.
-6	21A88	CAPACITOR, 2.2MF, 35V, TANTALUM
-7	6R75	RESISTOR, .47 , 2W, W. W.
-8	6356224	RESISTOR, 5.6K, ¼W, 2%
-9	6310324	RESISTOR, 10K, ¼W, 2%
-10	6368224	RESISTOR, 6.8K, ¼W, 2%
-11	6322324	RESISTOR, 22K, ¼W, 2%
-12	6368324	RESISTOR, 68K, ¼W, 2%
-13	6R296	RESISTOR, 470 , 2W, W. W.
-14	11M258	HYSOL, PC18

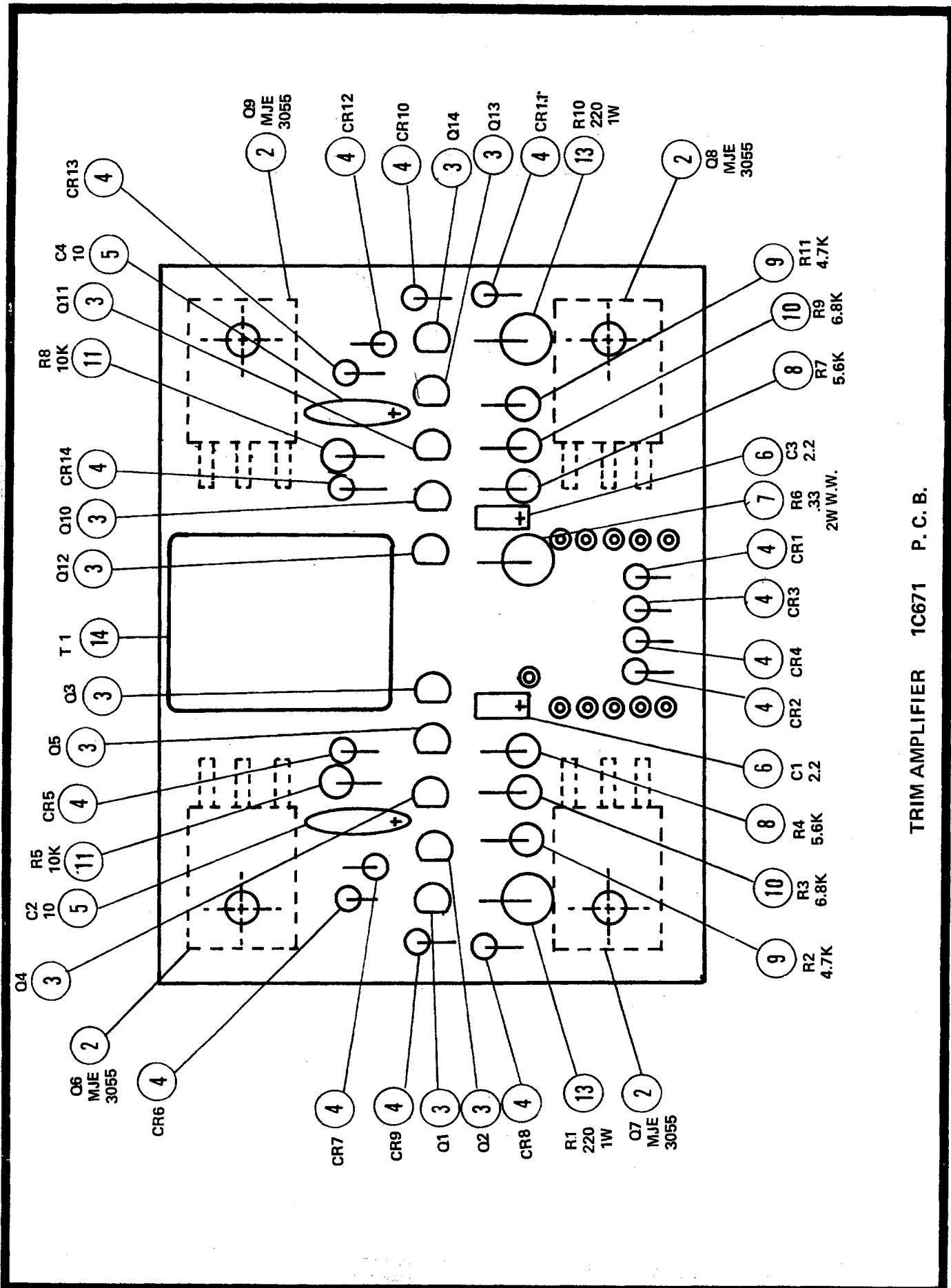

TRIM AMPLIFIER 1C671 P. C. B.

**PRINTED CIRCUIT BOARD ASSEMBLY FOR
TRIM AMPLIFIER MANUAL/AUTOMATIC, 1C671**

ITEM NO.	PART NO.	DESCRIPTION
-1	27B196	PRINTED CIRCUIT BOARD
-2	48S73	TRANSISTOR, MJE 3055
-3	48S69	TRANSISTOR, 2N4401
-4	48S33	DIODE, IN4001
-5	21S138	CAPACITOR, 33 MF, 20V, TANTALUM
-6	21A88	CAPACITOR, 2.2MF, 35V, TANTALUM
-7	6R326	RESISTOR, .33 , 2W, W. W.
-8	6356224	RESISTOR, 5.6K, 1/4W, 2%
-9	6347224	RESISTOR, 4.7K, 1/4W, 2%
-10	6368224	RESISTOR, 6.8K, 1/4W, 2%
-11	6310324	RESISTOR, 10K, 1/4W, 2%
-12		
-13	6R147	RESISTOR, 220 , 1W, 5%, CARBON
-14	80S17	RELAY 4PDT, P&B TYPE KHC 17D11 (12V COIL)
-15	10M85	SOLDER
-16	11M258	HYSOL PC18

TRIM AMPLIFIER 79C53 P. C. B.

REVISED SCHEMATIC 3-30-75

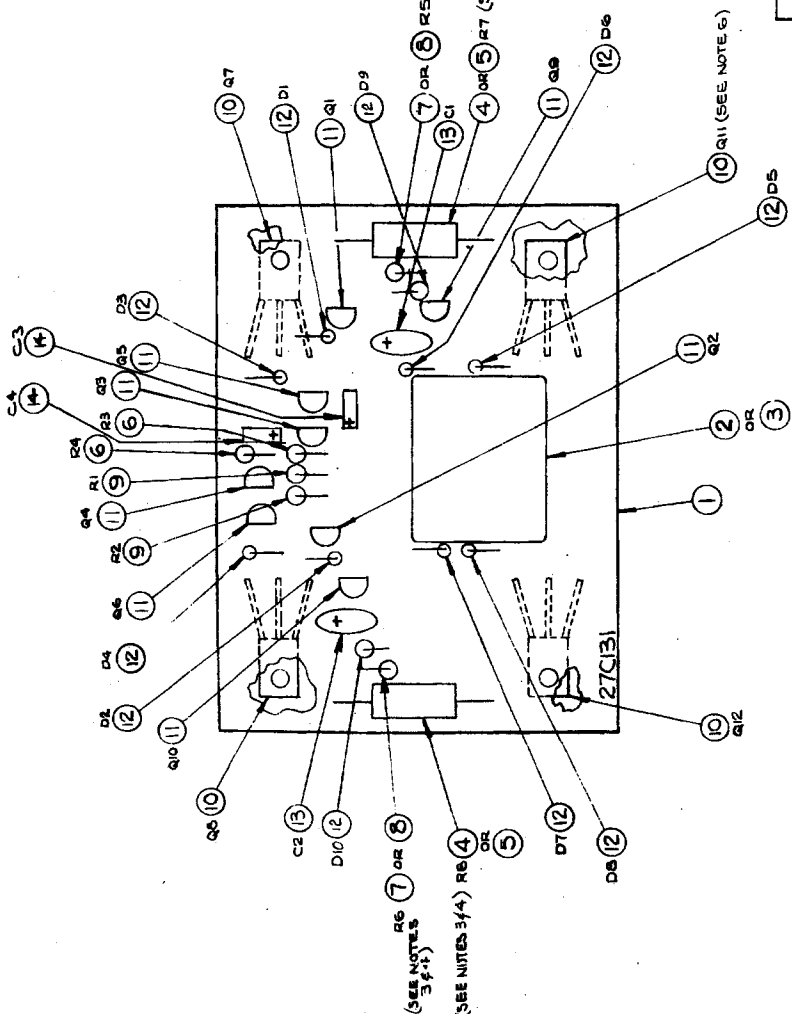

- NOTES:
1. 79C70-1 IS 14VDC UNIT
 2. 79C70-2 IS 28VDC UNIT
 3. USE ITEMS # 2, 4 & 7 FOR 14VDC UNIT (REF)
 4. USE ITEMS # 3, 5 & 8 FOR 28VDC UNIT (REF)
 5. STORE MICA DISCS THAT COME WITH TRANSISTORS, FOR USE AT NEXT ASSY. 79C53-1-2
 6. 48AG6 TRANSISTORS (ITEM 10) TO BE INSTALLED WITH THEIR COPPER SIDE AWAY FROM BOARD (ITEM 1)
 7. INSTALL ALL ITEM 12 WITH CATHODES (BANDS) NEXT TO BOARD.
 8. BE WARE FOR AUTH. SUBSTITUTION OF CARBON RESISTOR.

(SEE NOTES 3 & 4)
 (SEE NOTES 3 & 4)
 (SEE NOTES 3 & 4)
 (SEE NOTES 3 & 4)

SEE NOTE 7

SEE NOTE 5

SEE NOTE 8

ITEM NO.	QTY	PART NO.	ZONE	DESCRIPTION
14	2	21A85		CAPACITOR, 2.2MF, 35 WVDC, ±20%
13	2	21S151		CAPACITOR, 10-47, 35WVDC, TANTALUM
12	10	48553		DIODE (1N4001)
11	5	48569		TRANSISTOR (2N4401)
10	4	48AG6		TRANSISTOR (2N591)
9	2	636222		RESISTOR, 68K, 1/4W, 2%
8	2	636224		RESISTOR, 22K, 1/4W, 2%
7	2	630374		RESISTOR, 10K, 1/4W, 2%
6	2	635224		RESISTOR, 5.6K, 1/4W, 2%
5	2	GR215		RESISTOR, 220Ω, 3W, ±5%
4	2	GR214		RESISTOR, 50Ω, 3W, ±5%
3	1	80520		RELAY (2AVDC)
2	1	80577		RELAY (2VDC)
1	1	27C131		PC BOARD

NO.	REVISION	DATE	BY	TOLERANCES UNLESS OTHERWISE SPECIFIED
A	REVISED	3-23-77	C. D. ...	
B	
C	
D	
E	

SCALE: 2:1

P.C. BOARD ASSY., AMPLIFIER, PITCH TRIM SERVOS (PIPER)

MITCHELL INDUSTRIES INC. 79C70-2
 MUNICIPAL AIRPORT, MINERAL WELLS, TEXAS SHEET 1 OF 1

PRINTED CIRCUIT BOARD ASSEMBLY AMPLIFIER, TRIM 79C53

ITEM NO.	PART NO.	DESCRIPTION
-1	27C131-1	PRINTED CIRCUIT BOARD
-2	80S17	RELAY (12 VDC)
-3	80S20	RELAY (24 VDC)
-4	6R124	RESISTOR, 50 OHM, 3W, $\pm 5\%$
-5	6R215	RESISTOR, 220 OHM, 3W, $\pm 5\%$
-6	6R71	RESISTOR, 5.6K, $\frac{1}{2}W$, $\pm 5\%$
-7	6R31	RESISTOR, 10K, $\frac{1}{2}W$, $\pm 10\%$
-8	6R62	RESISTOR, 22K, $\frac{1}{2}W$, $\pm 10\%$
-9	6R154	RESISTOR, 6.8K, $\frac{1}{2}W$, $\pm 5\%$
-10	48S73	TRANSISTOR, MJE 3055
-11	48S69	TRANSISTOR, 2N4401
-12	48S33	DIODE (1N4001)
-13	21S151	CAPACITOR, 10 MF, 35 WVDC, TANTALUM
-14	21A88	CAPACITOR, 2.2 'F. 35 WVDC, $\pm 20\%$
-15	21S138	CAPACITOR, 33 MF, 20 WVDC, $\pm 20\%$

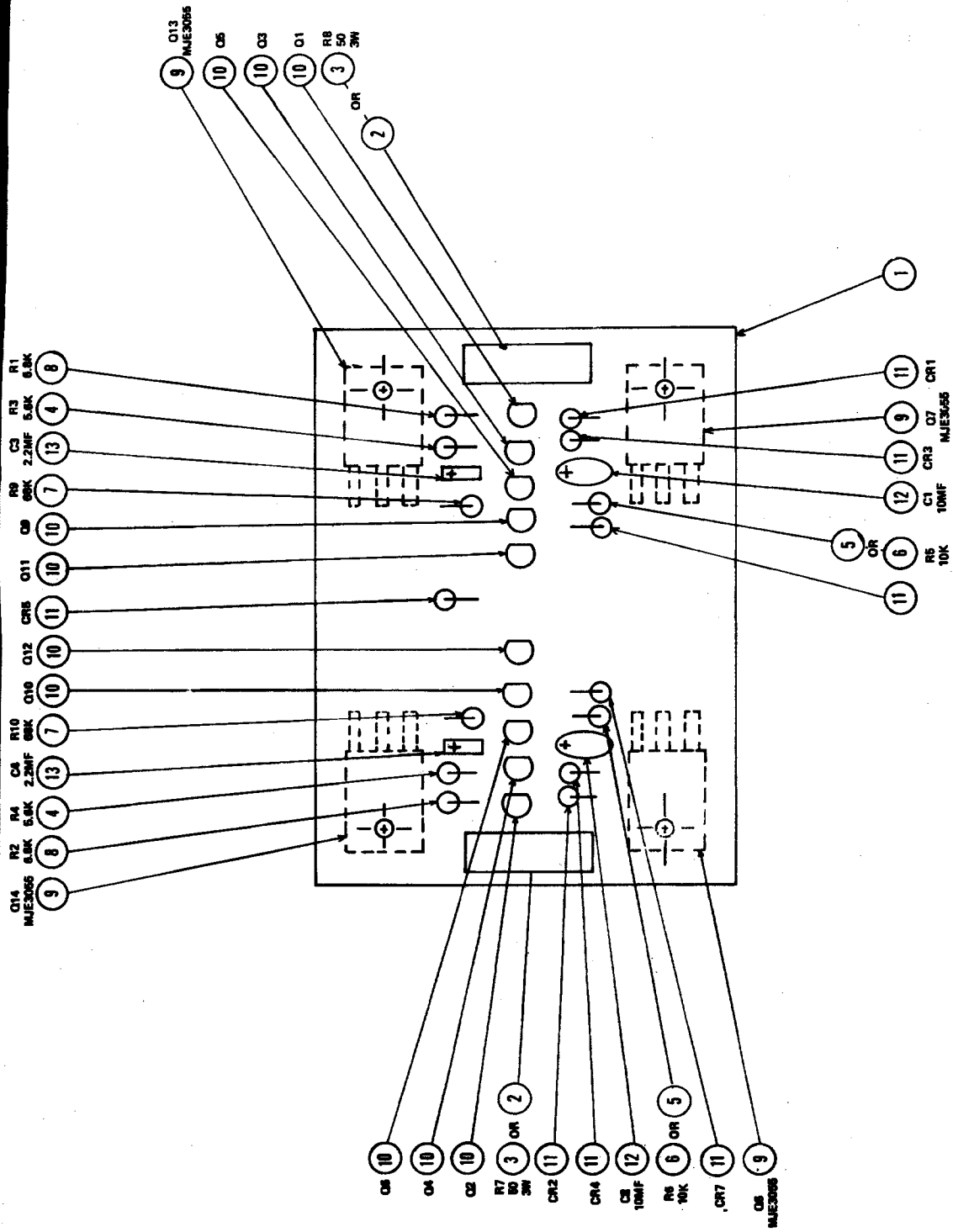

TRIM AMPLIFIER 79C54 P. C. B. & -3 P. C. B.

PRINTED CIRCUIT BOARD ASSEMBLY AMPLIFIER, TRIM 79C54

ITEM NO.	PART NO.	DESCRIPTION
-1	27C131	PRINTED CIRCUIT BOARD
-2	6R214	RESISTOR, 50 , 3W ±5%
-3	6R215	RESISTOR, 220 , 3W, ± 5%
-4	6356224	RESISTOR, 5.6K, ¼W, 2%
-5	6310324	RESISTOR, 10K, ¼W, 2%
-6	6322324	RESISTOR, 22K, ¼W, 2%
-7	6368324	RESISTOR, 68K, ¼W, 2%
-8	48A68	TRANSISTOR, (2N5191)
-9	48S69	TRANSISTOR, (2N4401)
-10	48S33	DIODE (1N4001)
-11	21S151	CAPACITOR, 10 , 35 WVDC, TANTALUM
-12	6368224	RESISTOR, 6.8K, ¼W, 2%
-13	21A88	CAPACITOR, 2.2 , 35 WVDC, ± 20%

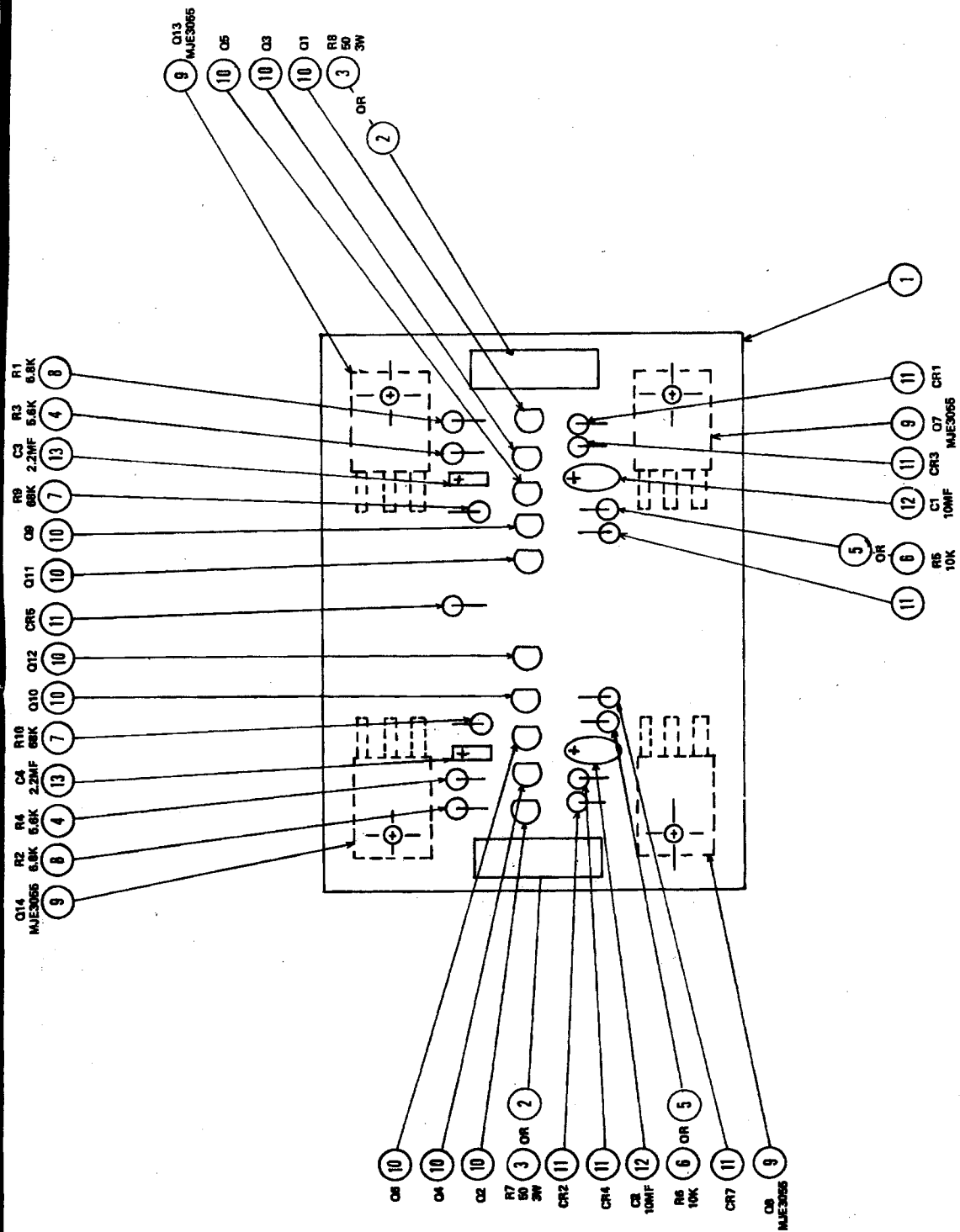

TRIM AMPLIFIER 79C54 P. C. B. & -3 P. C. B.

PRINTED CIRCUIT BOARD ASSEMBLY TRIM AMPLIFIER, 79C54-3

ITEM NO.	PART NO.	DESCRIPTION
-1	27D178	PRINTED CIRCUIT BOARD
-2	48S69	TRANSISTOR, 2N4401
-3	48S64	TRANSISTOR, 2N4403
-4	48S68	TRANSISTOR, 2N5191
-5	48S33	DIODE, IN4001
-6	21A88	CAPACITOR, 2.2MF, 35V., TAN.
-7	21S151	CAPACITOR, 10MF, 35V. TAN
-8	21S114	CAPACITOR, .22MF ERIE
-9	21S118	CAPACITOR, 1MF, ERIE
-10	6R215	RESISTOR, 220, 3W, 5%
-11	6R152	RESISTOR, 5.6K, 1/2W, 5%
-12	6R154	RESISTOR, 6.8K, 1/2W, 5%
-13	6R157	RESISTOR, 22K, 1/2W, 5%
-14	6R168	RESISTOR, 68K, 1/2W, 5%
-15	6R180	RESISTOR, 2.7K, 1/2W, 5%
-16	6R197	RESISTOR, 33K, 1/2W, 5%
-17	6R187	RESISTOR, 1K, 1/2W, 5%
-18	6R133	RESISTOR, 3.3K, 1/2W, 5%
-19	6R143	RESISTOR, 15K, 1/2W, 5%
-20	11M258	HYSOL, PC 18

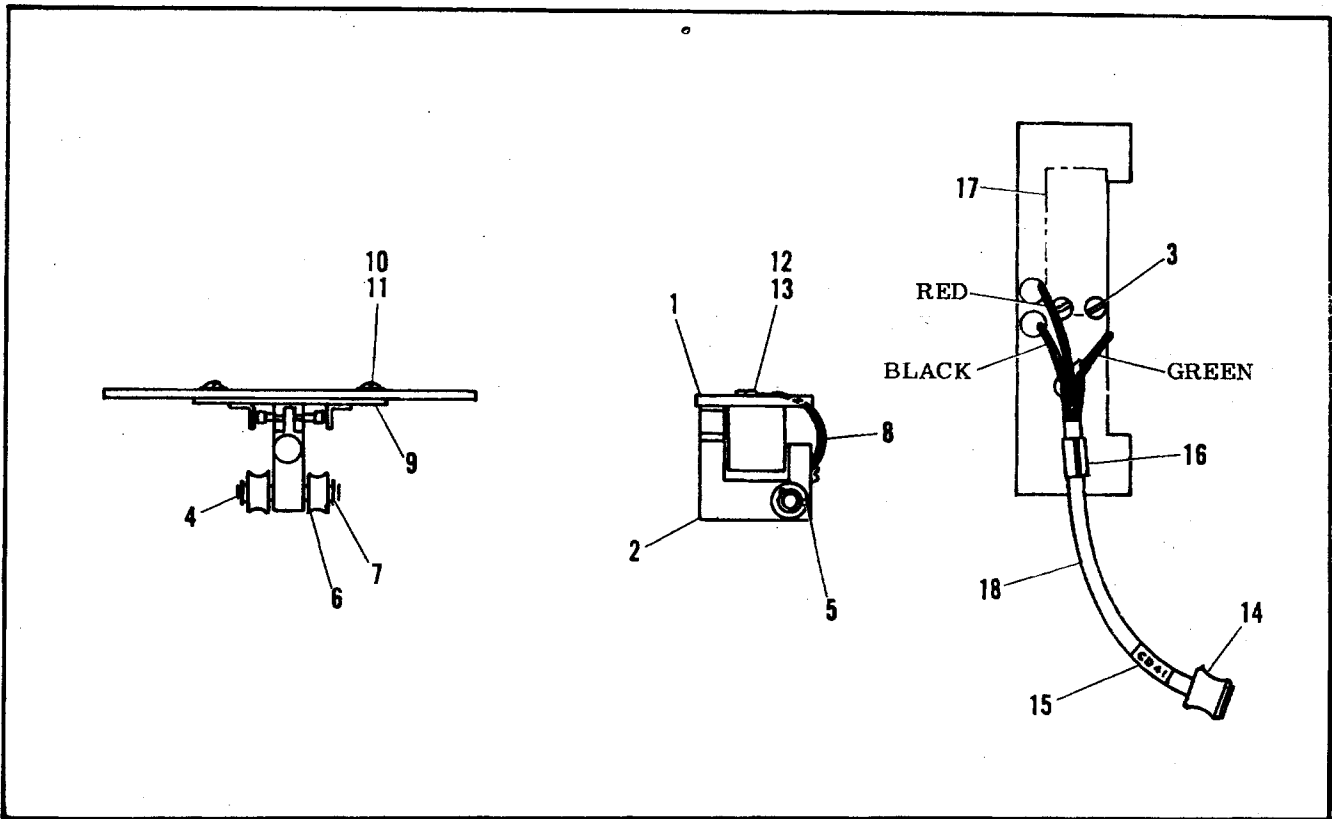

1C318 Pitch Trim Sensor Assembly

FIGURE AND INDEX NUMBER	PART NUMBER	1 2 3 4 5 6 7	DESCRIPTION	UNITS PER ASSEMBLY	USABLE ON CODE
11-14-	1C318		PITCH TRIM SENSOR ASSEMBLY	1	
-1	37B6R 1		. CHASSIS	1	
-2	1B324		. PIVOT ASSEMBLY	1	
-3	3S162		. SCREW, 6-32 x 7/16 Flat Hd	2	
-4	47A194		. SHAFT	1	
-5	3S89		. SET SCREW, 4-40 x 1/8 Allen Hd	1	
-6	49A24		. PULLEY	2	
-7	42S155		. TRUARC RING (Walde #5555-18)	2	
-8	10M62		. GROUND WIRE, 1/16" Braided copper	2"	
-9	1A325		. ADJUSTMENT BRACKET ASSEMBLY	1	
-10	3S65		. SCREW, 4-40 x 1/4 IN. Round Hd	2	
-11	4S87		. WASHER, 1/8 IN. ID x 5/16 OD x 1/32T	2	
-12	3S59		. SCREW, 8-32 x 3/16 B. H.	1	
-13	29S40		. LUG, Solder	1	
-14	9S36		. CONNECTOR	1	
-15	13A222		. LABEL CD-41	41	
-16	29S16		. CLAMP	1	
-17	13A265-1		. LABEL S/N	1	
-18	11M98		. SLEEVING	6"	
NOTE: Items 1 and 6 may change for different installations.					

1C318 - PITCH TRIM SENSOR ASSEMBLY

ITEM NO.	PART NO.	DESCRIPTION
-1	27B68-1	CHASSIS
-2	1B324	PIVOT ASSEMBLY
-3	3S162	SCREW, 6-32 x 7/16 Flat Hd.
-4	47A194	SHAFT
-5	3S89	SET SCREW, 4-40 x 1/8 Allen Hd.
-6	49A24	PULLEY
-7	42S155	TRUARC RING (Walde No. 5555-18)
-8	10M62	GROUND WIRE, 1/16" Braided copper
-9	1A325	ADJUSTMENT BRACKET ASSEMBLY
-10	3S65	SCREW, 4-40 x 1/4 IN. Round Hd.
-11	4S87	WASHER, 1/8 IN. ID x 5/16 OD x 1/32T
-12	3S59	SCREW, 8-32 x 3/16 B. H.
-13	29S40	LUG, Solder
-14	9S36	CONNECTOR
-15	13A222	LABEL CD-41
-16	29A16	CLAMP
-17	13A265-1	LABEL S/N
-18	11M98	SLEEVING

NOTE: Items 1 and 6 may change for different installations.

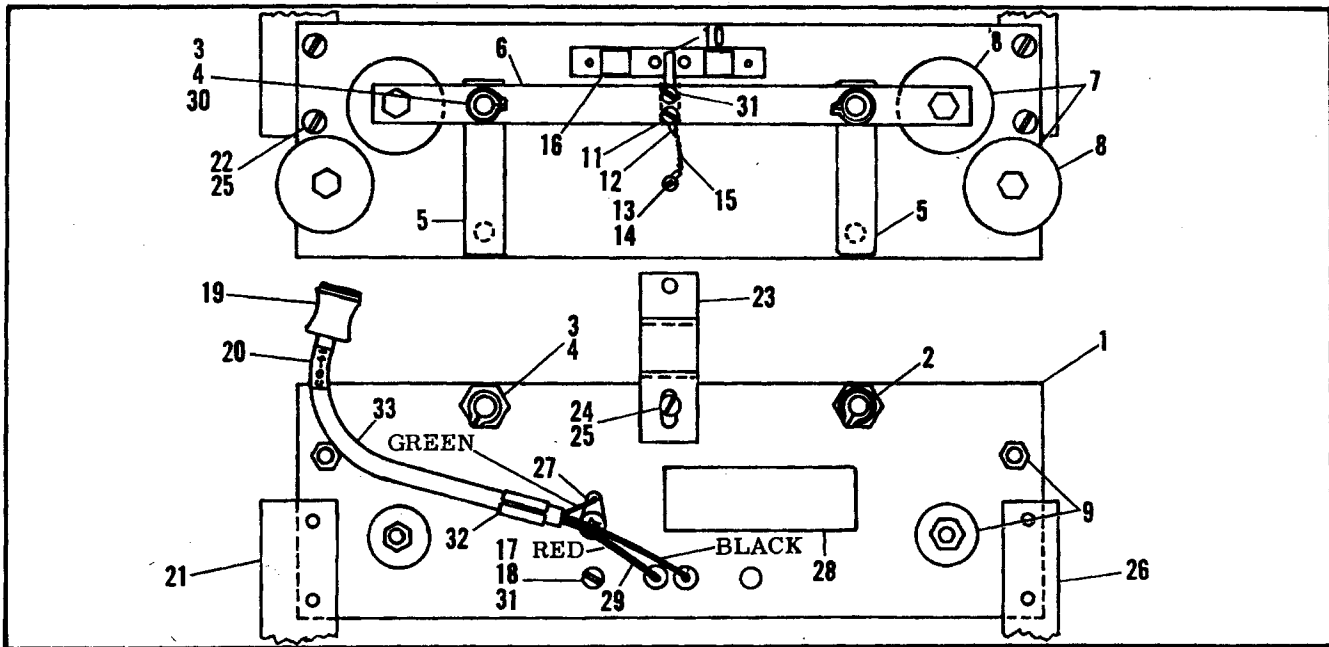

1C326 Pitch Trim Sensor Assembly

FIGURE AND INDEX NUMBER	PART NUMBER	1 2 3 4 5 6 7							DESCRIPTION	UNITS PER ASSEMBLY	USABLE ON CODE
11-10-	1C326	PITCH TRIM SENSOR ASSEMBLY								1	
-1	27B70	. CHASSIS								1	
-2	43A137	. PANEL BUSHING								2	
-3	4S114	. WASHER, 1/4 IN. L.D., 3/8 IN. O.D. x .010 S.S.								4	
-4	42S75	. TRUARC RING, 1/4 (TruArc #5100-25)								2	
-5	45A47	. BAR, Linkage								1	
-6	45A46	. BAR, Linkage								4	
-7	49A25	. PULLEY								4	
-8	3S106	. BOLT, 10-32 x 3/4 (AN3-6)								4	
-9	2S38	. NUT, 10-32 Esna								4	
-10	46A122	. BLOCK, Contact								1	
-11	3S133	. SCREW, 4-40 x 5/8 R. H.								2	
-12	29S56	. LUG, Solder NO. 4								1	
-13	29A46	. LUG, Solder NO. 2								1	
-14	3S61	. SCREW, 2-56 x 1/8 B. H.								1	
-15	10M62	. WIRE, 1/16 IN. Braided copper								1-1/2"	
-16	1A325	. ADJUSTMENT BRACKET ASSY								1	
-17	3S27	. SCREW, 4-40 x 1/4 B. H.								2	
-18	4S87	. WASHER, .119 L.D. x 9/32 O.D. x .025 thk steel								2	
-19	9S36	. CONNECTOR (Alden #4031)								1	
-20	13A222	. LABEL (CD-41)								1	
-21	7A642	. BRACKET, Mounting								1	
-22	3S95	. SCREW, 8-32 x 5/16								4	
-23	7A442	. BRACKET, Support								1	
-24	3S117	. SCREW, 8-32 x 1/4								1	
-25	4S61	. LOCKWASHER, NO. 8								6	
-26	7A641	. BRACKET, Mounting								1	
-27	29S40	. LUG, Solder NO. 8								1	
-28	13A265-1	. LABEL S/N								1	
-29	3S59	. SCREW, 8-32 x 3/16 B. H.								1	
-30	4S119	. SHIMWASHER, 1/4 IN. L.D., 3/8 IN. O.D. x .002T S.S.								AR	
-31	4S40	. LOCKWASHER, NO. 4 Int.								3	
-32	29S16	. CLAMP								1	
-33	11M98	. SLEEVING								6"	

1C326 - PITCH TRIM SENSOR ASSEMBLY

ITEM NO.	PART NO.	DESCRIPTION
-1	27B70	CHASSIS
-2	43A137	PANEL BUSHING
-3	4S114	WASHER, 1/4 IN. I. D. , 3/8 IN. O. D. x .010 S. S.
-4	42S75	TRUARC RING, 1/4 (TruArc No. 5100-25)
-5	45A47	BAR, Linkage
-6	45A46	BAR, Linkage
-7	49A25	PULLEY
-8	3S106	BOLT, 10-32 x 3/4 (AN3-6)
-9	2S38	NUT, 10-32 Esna
-10	46A122	BLOCK, Contact
-11	3S133	SCREW, 4-40 x 5/8 R. H.
-12	29S56	LUG, Solder No. 4
-13	29A46	LUG, Solder No. 2
-14	3S61	SCREW, 2-56 x 1/8 B. H.
-15	10M62	WIRE, 1/16 IN, Braided copper
-16	1A325	ADJUSTMENT BRACKET ASSY.
-17	3S27	SCREW, 4-40 x 1/4 B. H.
-18	4S87	WASHER, .119 I. D. x 9/32 O. D. x .025 thk steel
-19	9S36	CONNECTOR (Alden No. 4031)
-20	13A222	LABEL (CD-41)
-21	7A642	BRACKET, Mounting
-22	3S95	SCREW, 8-32 x 5/16
-23	7A442	BRACKET, Support
-24	3S117	SCREW, 8-32 x 1/4
-25	4S61	LOCKWASHER, No. 8
-26	7A641	BRACKET, Mounting
-27	29S40	LUG, Solder No. 8
-28	13A265-1	LABEL S/N
-29	3S59	SCREW, 8-32 x 16 B. H.
-30	4S119	SHIMWASHER, 1/4 IN. I. D. , 3/8 IN. O. D. x .002T S. S.
-31	4S40	LOCKWASHER, No. 4 Int.
-32	29S16	CLAMP
-33	11M98	SLEEVING

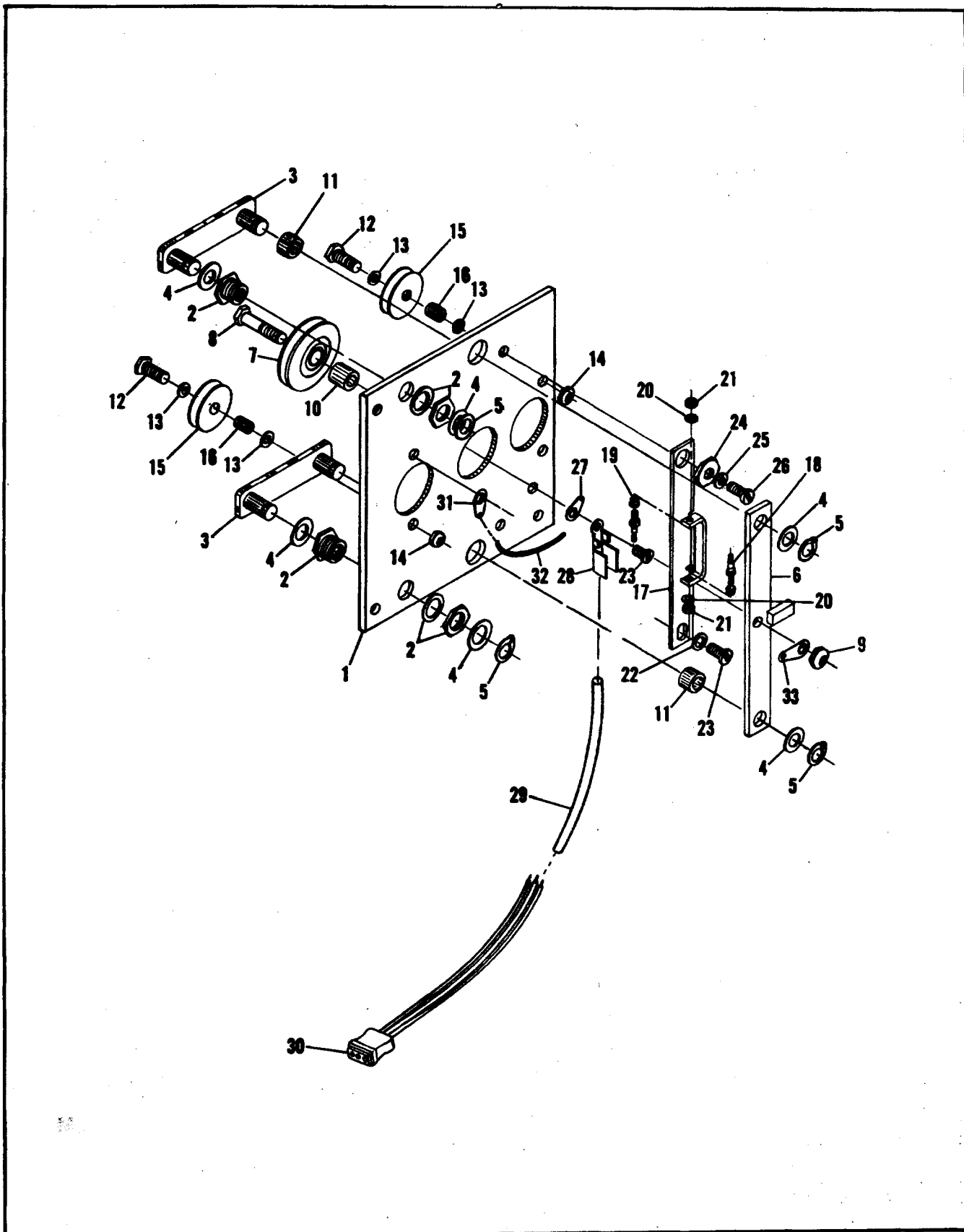

1C365 Trim Sensor Assembly

1C365 - TRIM SENSOR

ITEM NO.	PART NO.	DESCRIPTION
-1	See Note	CHASSIS
-2	43A137	PANEL BUSHING
-3	45A53	BAR, Linkage
-4	4S114	SHIMWASHER, 1/4 ID, 3/8 OD x .010
-5	42S75	TRUARC RING, 1/4 (Waldes No. 5100-25)
-6	45A52	BAR, Linkage
-7	49A22	PULLEY
-8	3S189	BOLT, 10-32 x 7/8 Hex Hd
-9	2S38	NUT, 10-32 Esna
-10	43A289	SPACER, 3/16 x ID x 3/8 OD x 3/16L
-11	43A288	SPACER, 1/4 ID x 3/8 OD x 3/16L
-12	3S334	SCREW, 6-32 11/16 B. H.
-13	4S160	WASHER
-14	2S30	NUT, 6-32 Esna
-15	49A30	PULLEY
-16	43A287	SPACER
-17	1A370	ADJUSTMENT BRACKET
-18	29S32	STANDOFF
-19	4S154	SHIMWASHER, .008 ID x .156 OD x .006T
-20	4S16	LOCKWASHER, NO. 2 Int.
-21	2S46	NUT, 2-56 Hex
-22	4S61	LOCKWASHER, NO. 8 Int.
-23	3S59	SCREW, 8-32 x 3/16 B. H.
-24	45A45	CAM
-25	4S96	LOCKWASHER, NO. 6 Int.
-26	3S96	SCREW, 6-32 x 5/16 B. H.
-27	29S40	LUG, Solder No. 8
-28	29S16	CLAMP
-29	11M98	SLEEVING
-30	9S36	CONNECTOR (Alden No. 4031)
-31	29S44	LUG, Solder
-32	10M62	WIRE, 1/16 Braided Copper
-33	29S33	LUG, Solder
-34	13A320	LABEL, S/N
-35	13A222	LABEL, CD-41

NOTE: Use 27B85 Chassis on 1C365-151, 159, 187, 206, 214, 210, 238, 239,
and use 27B88 Chassis on 1C365-152, 188.

Section XI
Parts List

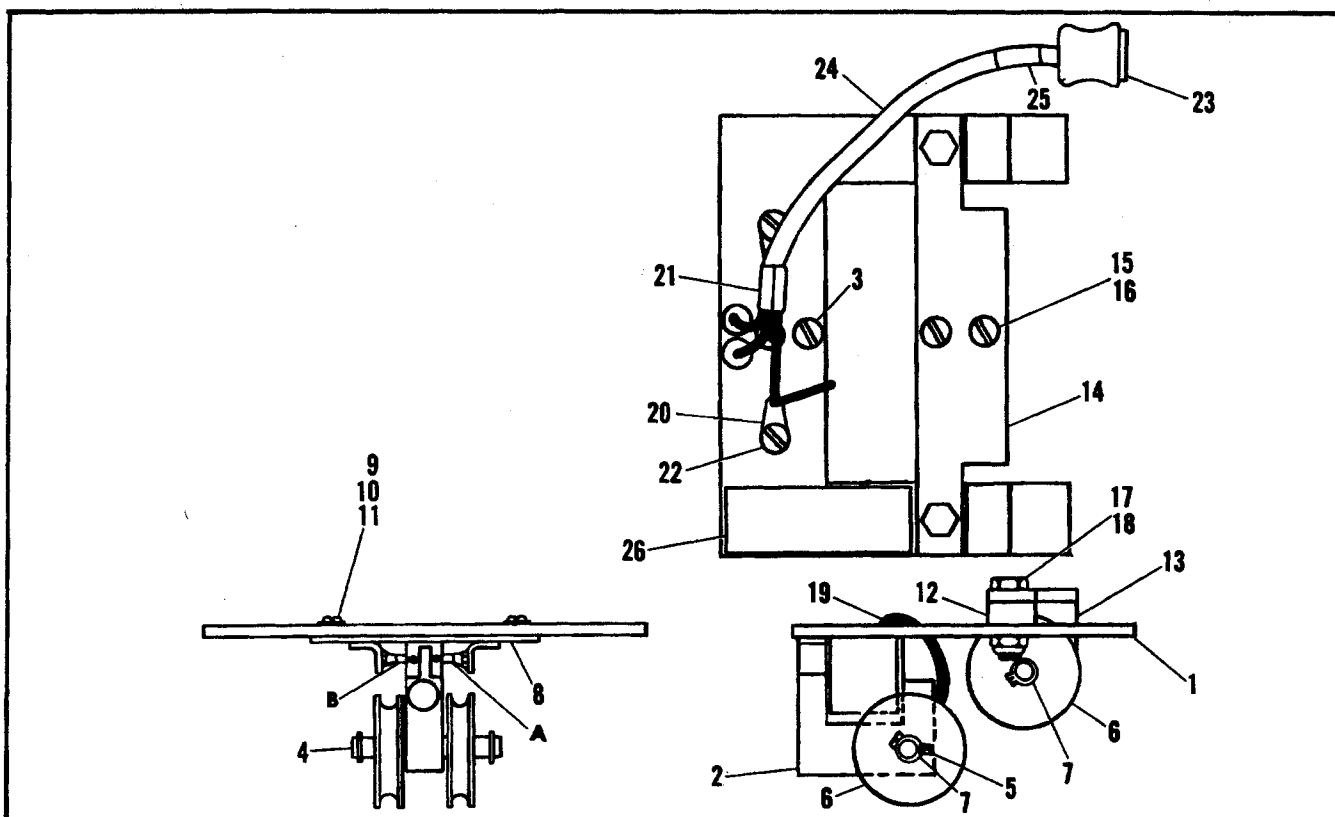

1C374 Pitch Trim Sensor Assembly

1C374 - PITCH TRIM SENSOR ASSEMBLY

ITEM NO.	PART NO.	DESCRIPTION
-1	27B64-1	CHASSIS
-2	1B324	PIVOT ASSEMBLY.
-3	3S162	SCREW 6-32 x 7/16 Flat Head
-4	47A219	SHAFT
-5	3S89	SET SCREW 4-40 x 1/8
-6	49A22	PULLEY
-7	42S155	TRUARC RING WALDES No. 5555-18
-8	1A325	ADJUSTMENT BRACKET ASSEMBLY
-9	3S65	SCREW 4-40 x 1/4" Round head.
-10	4S87	WASHER .1191. D. x 9/32 or x .025T
-11	4S40	WASHER No. 14 Int. Lock
-12	43A133	SPACER
-13	46A128	BLOCK
-14	7A459	BRACKET
-15	3S45	SCREW 8-32 x 3/8 Fil. Hd.
-16	4S61	LOCKWASHER No. 8 Int. Lock
-17	3S106	BOLT 10-32 x 3/4 " Hex Head
-18	2S38	NUT 10-32 Esna
-19	10M62	GROUND WIRE 1/16" braided copper
-20	29S40	SOLDER LUG
-21	29S16	CLAMP
-22	3S59	SCREW 8-32 x 3/16" B. H.
-23	9S36	RECEPTACLE.
-24	11M98	SLEEVING
-25	13A222	LABEL CD-41
-26	13A265-1	LABEL S/N

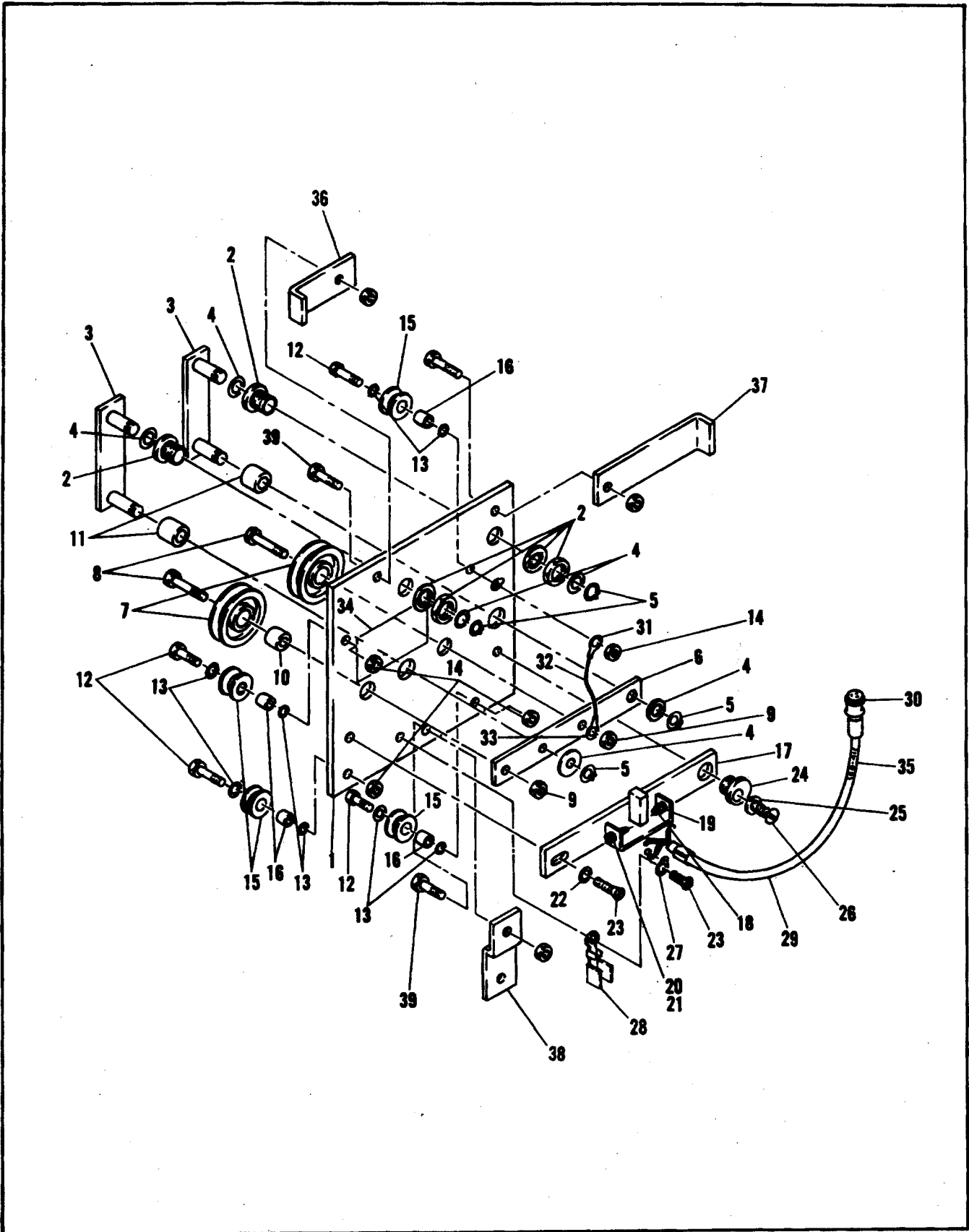

1C377-Trim Sensor Assembly

1C377 - TRIM SENSOR

ITEM NO.	PART NO.	DESCRIPTION
-1	27B89	CHASSIS
-2	43A137	BUSHING, Panel
-3	45A53	BAR, Linkage
-4	4S114	SHIMWASHER, 1/3 ID. x 3/8 OD x .010
-5	42S75	TRUARC RING, 1/4 IN. (Waldes No. 5100-25)
-6	45A54	BAR, Linkage
-7	49A31	PULLEY
-8	3S189	BOLT, 10-32 x 7/8 Hex Hd.
-9	2S38	NUT, 10-32 Esna
-10	43A289	SPACER, 3/16 ID x 3/8 OD x 3/16 L
-11	43A288	SPACER, 1/4 ID x 3/8 OD x 3/16L.
-12	3S334	SCREW, 6-32 x 11/16 B. H.
-13	4S121	WASHER
-14	2S30	NUT, 6-32 Esna
-15	49A24	PULLEY
-16	43A287	SPACER
-17	1A370	BRACKET, Adjustment
-18	29S32	STANDOFF.
-19	4S154	SHIMWASHER, .008 ID x .156 OD x .006T
-20	4S16	LOCKWASHER, No. 2 Int.
-21	2S46	NUT, 2-56 Hex
-22	4S61	LOCKWASHER, No. 8 Int.
-23	3S59	SCREW, 8-32 x 3/16 B. H.
-24	45A45	CAM
-25	4S96	LOCKWASHER, No. 6 Int.
-26	3S36	SCREW, 6-32 x 5/16 B. H.
-27	29S40	LUG, Solder, No. 8
-28	29S16	CLAMP
-29	11M98	SLEEVING
-30	9S36	CONNECTOR (Alden No. 40.31)
-31	29S44	LUG, Solder
-32	10M62	WIRE, 1/16 Braided Copper
-33	29S33	LUG, Solder
-34	13A222	LABEL, CD-41
-35	13A265-1	LABEL, S/N
-36	7A542	BRACKET, Mtg
-37	7A543	BRACKET, Mtg
-38	7A544	BRACKET, Support
-39	3S92	BOLT, 10-32 x 1/2 Hex

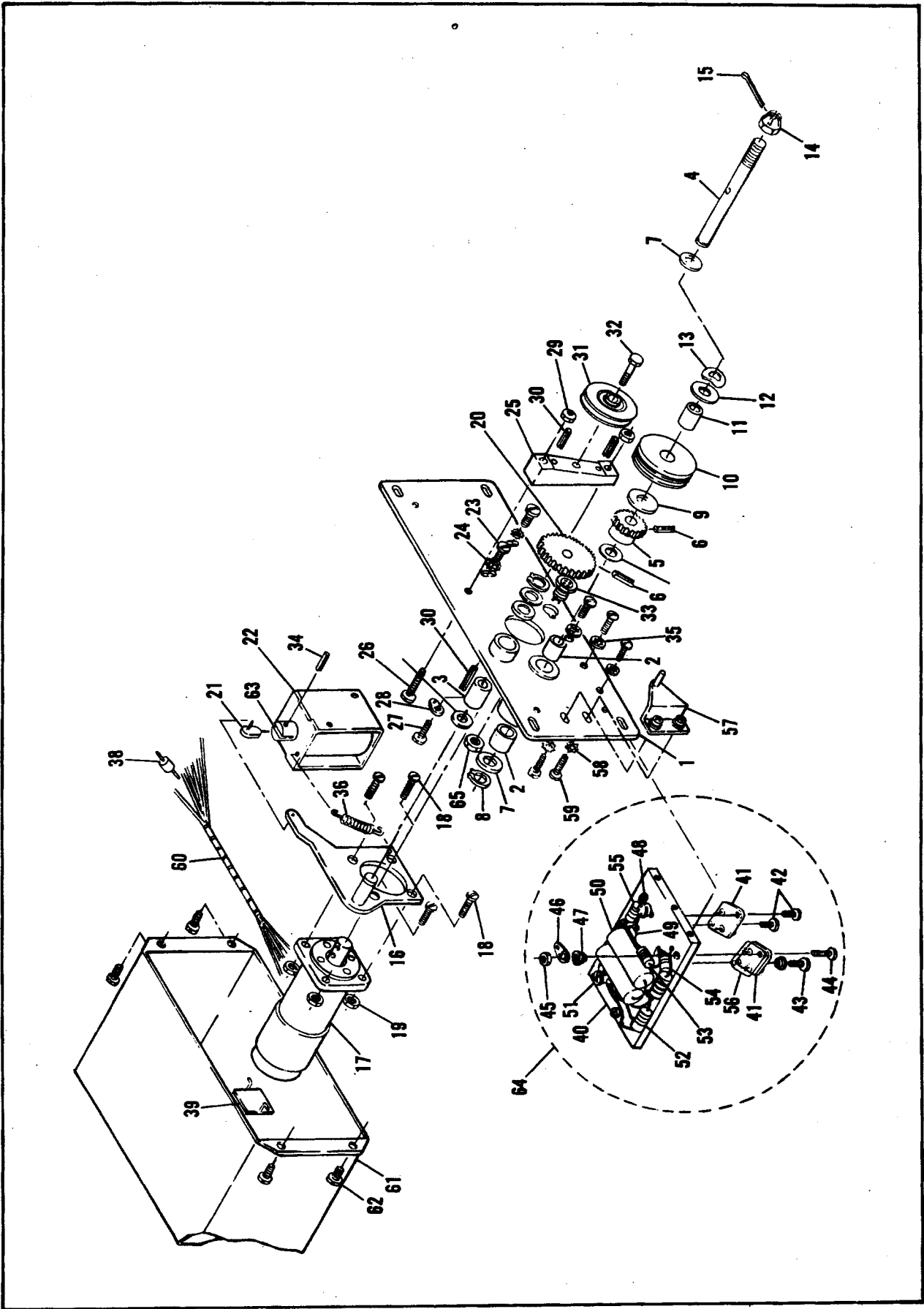

Typical Trim Servo

TYPICAL TRIM SERVO
(SEE TABLE 1)

ITEM NO.	PART NO.	DESCRIPTION
-1	See table 1	CHASSIS ASSEMBLY
-2	43S73	BEARING (Torrington No. B-57)
-3	43A272	BEARING
-4	47A199	SHAFT
-5	See table 1	GEAR
-6	22S52	ROLL PIN, Esna No. 59-002-094-0750
-7	4S150	SHIMWASHER, 5/16 ID x 5/8 OD x .010T.
-8	4S156	SHIMWASHER, 5/16 ID x 5/8 OD x .003T
-9	4S157	SHIMWASHER, 5/16 ID x 5/8 OD x .030T.
-8	42S170	TRUARC RING (Waldes No. 5100-31)
-9	4A159	FRICTION DISC
-10	49A26	CAPSTAN
-11	43A276	BEARING
-12	4S153	SHIMWASHER, 5/16 ID x 3/4 OD x .010T.
-13	4A152	WASHER, Tension
-14	2S91	NUT, Castle 5/16-24 AN310-5.
-15	22S53	COTTER PIN, 1/16 x 3/4 AN380-2-3
-16	7B478-1	MOTOR BRACKET ASSEMBLY
-17	See table 1	MOTOR
-18	3S212	SCREW, 4-40 x 1/2 IN. B. H.
-19	2S40	NUT, 4-40 Esna
-20	See table 1	GEAR
-21	45A49	BAR, Linkage
-22	See table 1	SOLENOID
-23	3S102	SCREW, 10-32 x 1/4 IN. B. H..
-24	4S84	LOCKWASHER, NO. 10 Ext.
-25	46A107	BLOCK, Idler Support
-26	3S296	SCREW, 6-32 x 7/8 B. H..
-27	3S288	SCREW, 6-32 x 5/8 B. H..
-28	29S44	LUG, Solder No. 6
-29	2S30	NUT, 6-32 Esna
-30	22S31	ROLL PIN, 3/32 x 1/2 In. Esna No. 59-002-094-0550
-31	49A22	PULLEY
-32	3S291	BOLT, 10-32 x 5/8 Hex Hd Long-Loc
-33	9S74	RECEPTACLE (5 pin)
-34	22S7	ROLL PIN, Esna No. 59-028-125-0437
-35	4S40	LOCKWASHER, No. 4 Int.
-36	41A88	SPRING
-37	6R94	RESISTOR, 180 Ohm, 1/2W, 10%
-38	48S33	DIODE, IN4001
-39	8S13	CAPACITOR, 1 MFD
-40	27B75	AMPLIFIER CHASSIS
-41	48S23	TRANSISTOR, MN 92
-42	3S164	SCREW, 4-40 x 5/16 B. H.
-43	3S175	SCREW, 4-40 x 3/8 B. H..
-44	3S110	SCREW, 4-40 x 5/8 B. H..
-45	2S14	NUT, 4-40 Hex
-46	29S56	SOLDER LUG, NO. 4 Locking
-47	4A58	SHOULDER WASHER
-48	29S18	STANDOFF
-49	29S20	TERMINAL
-50	21S43	CAPACITOR

ITEM NO.	PART NO.	DESCRIPTION
-51	48S48	TRANSISTOR, MPS6519
-52	6R106	RESISTOR, 68 Ohm, 2 W
-53	6R107	RESISTOR, 150 Ohm, 1 W
-54	6R76	RESISTOR, 10 Ohm, 1/2 W
-55	6R23	RESISTOR, 3.3K, 1/2W
-56	14A46	INSULATOR
-57	7A382	BRACKET
-58	4S44	LOCKWASHER, NO. 6 Ext.
-59	3S295	SCREW, 6-32 x 9/16 B. H.
-60	30B182	CABLE ASSEMBLY
-61	15C144-2	COVER
-62	3S48	SCREW, 4-40 x 3/16 B. H.
-63	Part of Item 22	PLUNGER, Solenoid
-64	See Table 1	AMPLIFIER ASSEMBLY
-65	Part of 9S74 Assy.	NUT.
<p>NOTE 1: Cover not used on 1D373-171.</p> <p>NOTE 2: Replace 4A159 Friction Disc with 4A151 and 4B478-1 motor bracket assembly with 7B480-1 for servo 1D360.</p> <p>NOTE 3: Amplifier Assembly shown Item 64 is 1B389. For 1B369 substitute in place of Item 52, 6R123 resistor 270 ohm, 2 W, 10% 2 required and in place of item 53, 6R103 resistor 470 Ohm, 1 W, 10% 2 required.</p>		

This table lists differences in Trim Servos for particular aircraft. Servo Assembly Number is model number stamped on Servo label.

TABLE 1

Servo Assy	Chassis Item 1	Gear Item 5	Motor Item 17	Gear Item 20	Solenoid Item 22	Amp. Assy. Item 66
1D373-167	27B87-3	44A96	59A37	44A98	80A9	1B389
1D373-170	27B87-1	44A95	59A37	44A99	80A9	1B389
1D373-169	27B87-1	44A93	59A37	44A97	80A9	1B389
1D373-168	27B87-5	44A95	59A37	44A99	80A9	1B389
1D373-171	27B87-1	44A95	59A37	44A97	80A9	1B389
1D368-159	27B87-1	44A93	59A38	44A94	80A7-2	1B369
1D368-190	27B87-1	44A93	59A38	44A94	80A7-2	1B369
1D368-235	27B87-1	44A93	59A38	44A94	80A7-2	1B369
1D360	27B76-3	44A89	59A37	44A90	80A9	1B389

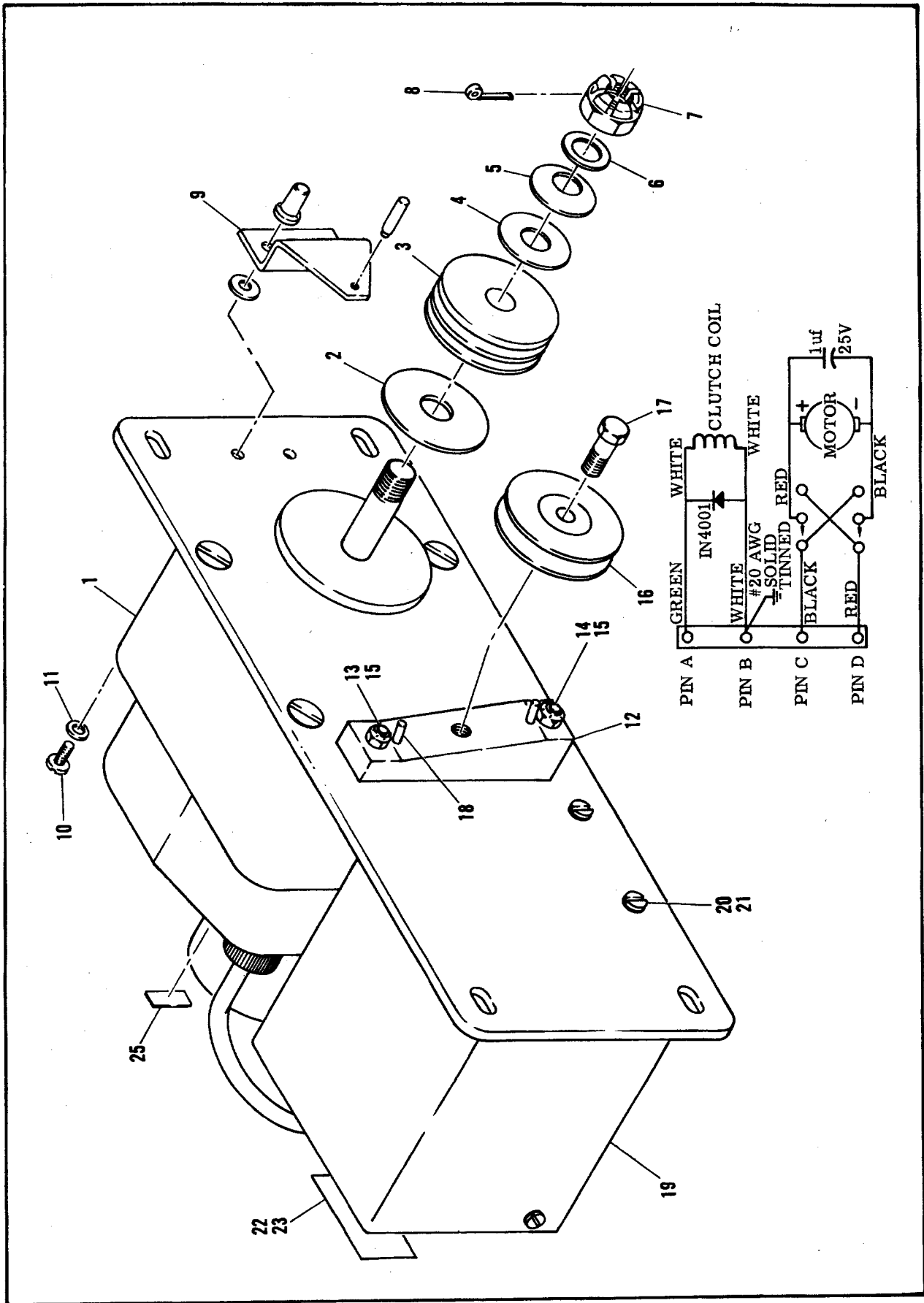

79D51 Pitch Trim Servo, 14 VDC, 30 RPM

79D51 - 14 VDC., 30 ROM PITCH TRIM SERVO ASSEMBLY

ITEM NO.	PART NO.	DESCRIPTION
-1	1C491	TRIM SERVO, 12V, 30 RPM
-2	4A188	FRICTION WASHER
-3	49A26-1	CAPSTAN ASSEMBLY
-4	4S153	SHIM WASHER, 5/16 LD x 3/4 OD x .010 THK S. S.
-5	4A152	TENSION WASHER
-6	4S156	SHIM WASHER, 5/16 LD x 5/8 OD x .003 THK S. S.
-7	2S91	NUT, Castle, 5/16-24 UNF-2B, AN310-5.
-8	22S53	COTTER PIN, 1/16 x 3/4, AN380-2-3.
-9	7A382	BRACKET(CABLE GUARD)
-10	3S295	SCREW, B. H. CAS PL STL. NO. 6-32 UNC-2A x 9/16
-11	4S44	LOCKWASHER, EXT. No. 6
-12	46A107	IDLER SUPPORT BLOCK
-13	3S296	SCREW, B. H. STL, No. 6-32 UNC-2A x 7/8
-14	3S288	SCREW, B. H. STL, No. 6-32 UNC-2A x 5/8
-15	2S30	NUT, Esna, No. 6-32 UNC-2B
-16	49A22	PULLEY
-17	3S291	BOLT, Hex-Hd. Long Loc, No. 10-32 UNC-2A x 5/8
-18	22S31	ROLL PIN, 3/32 x 1/2.
-19	79C53-1	AMPLIFIER ASSEMBLY
-20	3S164	SCREW, B. H. STL, No. 4-40 UNC-2A x 5/16.
-21	4S40	LOCKWASHER, INT. No. 4
-22	13A265	PLACARD (Model, Serial No.)
-23	11M191	SOLVENT
-24	4S161	S141M WASHER
-25	1BA438	LABEL (CD-73)

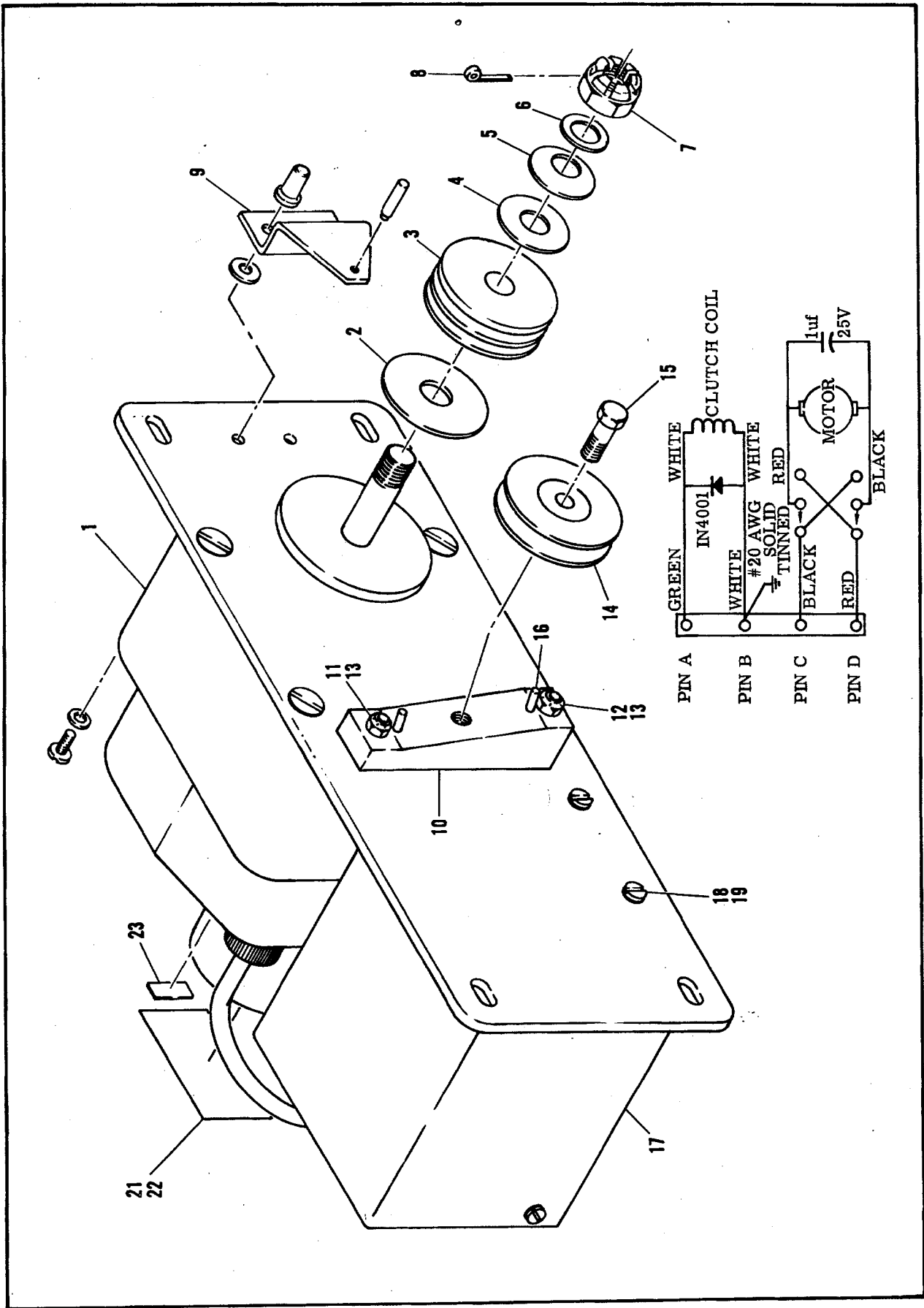

79D52 Pitch Trim Servo, 28 VDC, 20 RPM

79D52 - 28 VDC, 20 RPM PITCH TRIM SERVO ASSEMBLY

ITEM NO.	PART NO.	DESCRIPTION
-1	1C492	TRIM SERVO, 24V, 20 RPM
-2	4A188	WASHER, Friction
-3	49A26-1	CAPSTAN ASSEMBLY
-4	4S153	SHIMWASHER, 5/16 ID x 3/4 OD x .010 THK
-5	4A152	WASHER, Tension
-6	4S156	SHIMWASHER
-7	2S91	NUT, Castle, 5/16-24 UNF-2B, AN310-5.
-8	22S53	PIN, Cotter, 1/16 x 3/4 AN380-2-3
-9	7A382-2	BRACKET, Cable guard
-10	46A107	IDLER SUPPORT BLOCK
-11	3S296	SCREW, B. H. STL. No. 6-32 UNC-2A x 7/8
-12	3S288	SCREW, B. H. STL. No. 6-32 UNC-2A x 5/8
-13	2S30	NUT, Esna, No. 6-32 UNC-2B
-14	49A22	PULLEY
-15	3S291	BOLT, Hex Hd. Long Loc, No. 10-32 UNC-2A x 5/8
-16	22S31	ROLL PIN, 3/32 x 1/2.
-17	79C53-2	AMPLIFIER ASSEMBLY
-18	3S164	SCREW, B. H. , STL, No. 4-40 UNC-2A x 5/16
-19	4S40	LOCKWASHER, Int. No. 4.
-20	4S161	SHIMWASHER
-21	13A265	PLACARD (Model Serial No.)
-22	11M191	SOLVENT
-23	13A438	LABEL (CD-73)

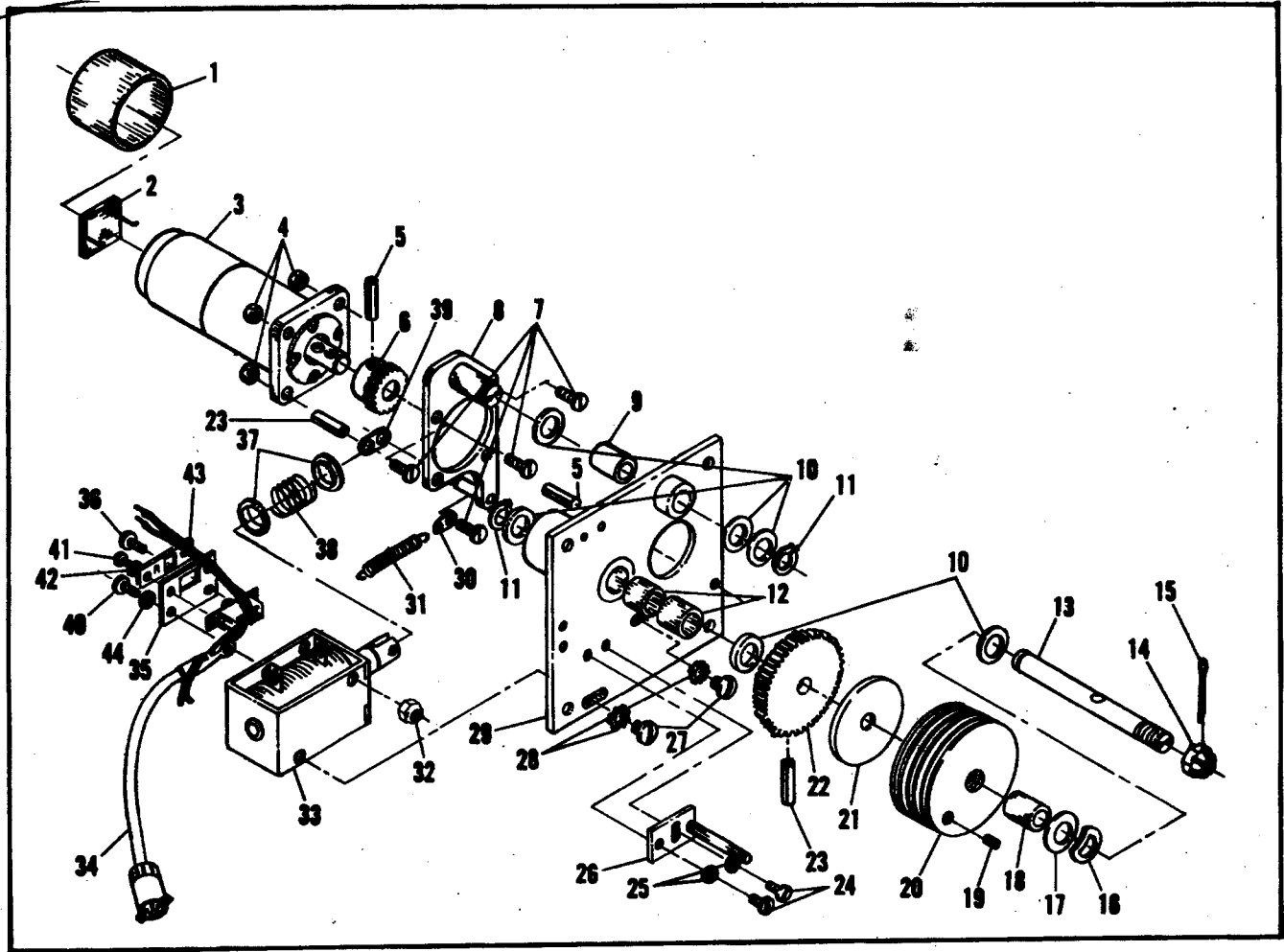

Typical Servo

**ROLL & PITCH SERVOS
(OLDER MITCHELL VERSION)
SEE TABLE 2**

ITEM NO.	PART NO.	DESCRIPTION
-1	28S20	CAP-PLUG
-2	8S13	CAPACITOR, Imfd
-3	59A37	MOTOR, Servo
-4	2S40	NUT, 4-40 Esna
-5	22S55	ROLL PIN
-6	44A91	GEAR
-7	3S212	SCREW, 4-40 x 1/2 B. H.
-8	7B512-1	MOTOR BRACKET ASSY.
-9	*43S71	BUSHING
-10	4S150	WASHER, 5/16 ID x 4/8 x 019 Thick
-11	42S170	TRUARC RINC, Waldes No. 5100-31
-12	*43S273	BEARING, Torrington No. B-57
-13	47A203	SHAFT
-14	2S91	NUT, 5/16 Castle, AN310-5.
-15	22S53	COTTER PIN, 1/16 x 3/4, AN380-2-3.
-16	4A152	TENSION WASHER
-17	4S153	WASHER, 5/16 x 3/4 OD x .010T .55.
-18	**43A272	BUSHING
-19	3S326	SET SCREW
-20	See Note 1	CAPSTAN ASSEMBLY
-21	4A155	FRICTION WASHER
-22	44A92	GEAR
-23	22S52	ROLL PIN
-24	3S174	SCREW
-25	4S96	LOCKWASHER, NO. 6 Int.
-26	See Note 3	CABLE GUARD
-27	3S102	SCREW, 10-32 x 1/4 B. H.
-28	4S84	LOCKWASHER, NO. 10 Ext. Lock
-29	27B84-1	CHASSIS ASSEMBLY
-30	29S31	LUG
-31	41A93	SPRING
-32	3S90	NUT, 8-32 Esna
-33	See Note 2	SOLENOID
-34	30A191	CABLE ASSEMBLY
-35	7A604	SWITCH MOUNTING BRACKET
-36	3S95	SCREW, 8-32 x 5/16 B. H.
-37	5S76	EYELET
-38	41A92	SPRING
-39	45A49	LINKAGE BAR
-40	3S59	SCREW, 8-32 x 3/16 B. H.
-41	3S131	SCREW, 2-56 x 3/16 B. H.
-42	4S16	LOCKWASHER, NO. 2 Int.
-43	7A605	SWITCH LIMITER BRACKET ASSEMBLY
-44	4S61	LOCKWASHER, NO. 8 Int.
-45	7A783 See Note 4B	PULLEY MOUNTING BRACKET
-46	43A343 See Note 4B	SPACER
-47	7A784 See Note 4B	CABLE GUARD
-48	3S237 See Note 4B	SCREW

ITEM NO.	PART NO.	DESCRIPTION
-49	2S34 See Note 4B	NUT.
-50	49S34 See Note 4B	PULLEY
-51	3S299 See Note 4B	BOLT
-52	2S38 See Note 4B	NUT.
<p>NOTE 1: A. 1C465 uses 49A28-3 Capstan B. 1C470 uses 49A38-1 C. 1D363 uses 49A28-1 D. 1D414 uses 49A28-1 E. 1C481 uses 49A28-1 F. 1C477 uses 49A28-1 G. 1D456 uses 49A38-1</p>		
<p>NOTE 2: A. 1C465 uses 80A7-6 Solenoid (24 V) B. 1C470 uses 80A7-6 C. 1D363 uses 80A9-6 D. 1D414 uses 80A7-6 E. 1C481 uses 80A9-6 F. 1C477 uses 80A9-6 G. 1D456 uses 80A9-6</p>		
<p>NOTE 3: Refer to aircraft installation manual and/or 7.1 table this section for cable guard requirements.</p>		
<p>NOTE 4: A. Model 1C363-182 (only) uses extra-large capstan with arm. No cable guard required. B. 1C481 is identical to 1D363 except for addition of cable pulley, brackets and cable guard, parts 2-3-45 through -52. C. 1C477 is identical to 1D363 except for base-plate modification.</p>		

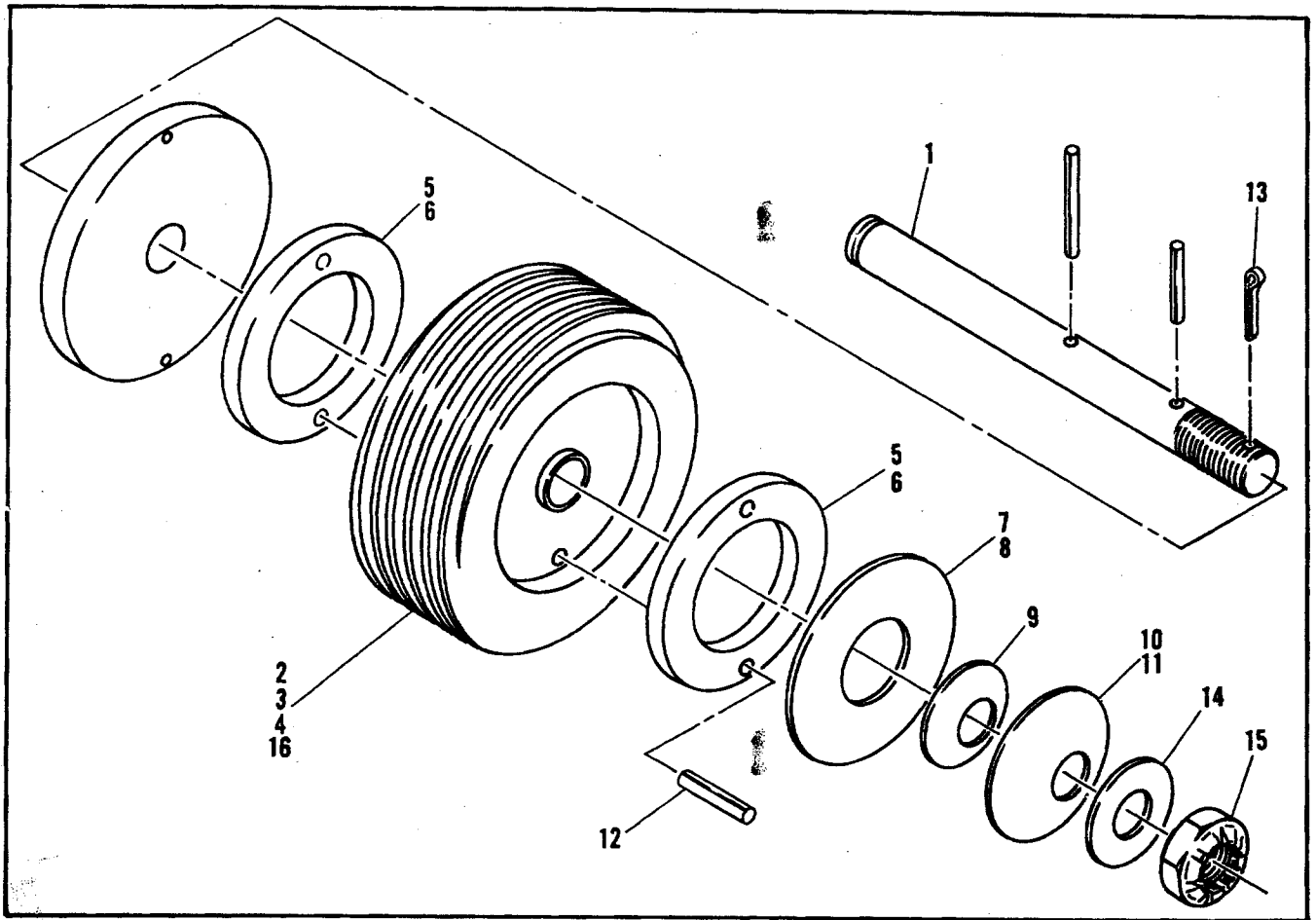

79B68-() - GEAR AND CAPSTAN ASSEMBLY

ITEM NO.	PART NO.	DESCRIPTION
-1	81A18	GEAR AND SHAFT ASSEMBLY
-2	49A28-1	CAPSTAN ASSEMBLY (used on 79B68-1)
-3	49A28-3	CAPSTAN ASSEMBLY (used on 69B68-2)
-4	49A38-1	CAPSTAN ASSEMBLY (used on 79B68-3)
-5	4A181	CLUTCH DISC (used on 79B68-1 and -2)
-6	4A181-1	CLUTCH DISC (used on 79B68-3)
-7	4A179	WASHER, Slotted (used on 79B68-1 and -2)
-8	4A179-1	WASHER, Slotted (used on 79B68-3)
-9	4A152	WASHER, Tension spring
-10	4A180	WASHER, Tension spring (used on 79B68-1 & -2).
-11	4A180-1	WASHER, Tension spring (used on 79B68-3)
-12	22S80	PIN, Roll, 5/64 Dia. x 1/2 lg
-13	22S53	KEY, Cotler
-14	4S150	WASHER, Flat, 5/16
-15	2S91	NUT, Castle, 5/16-24

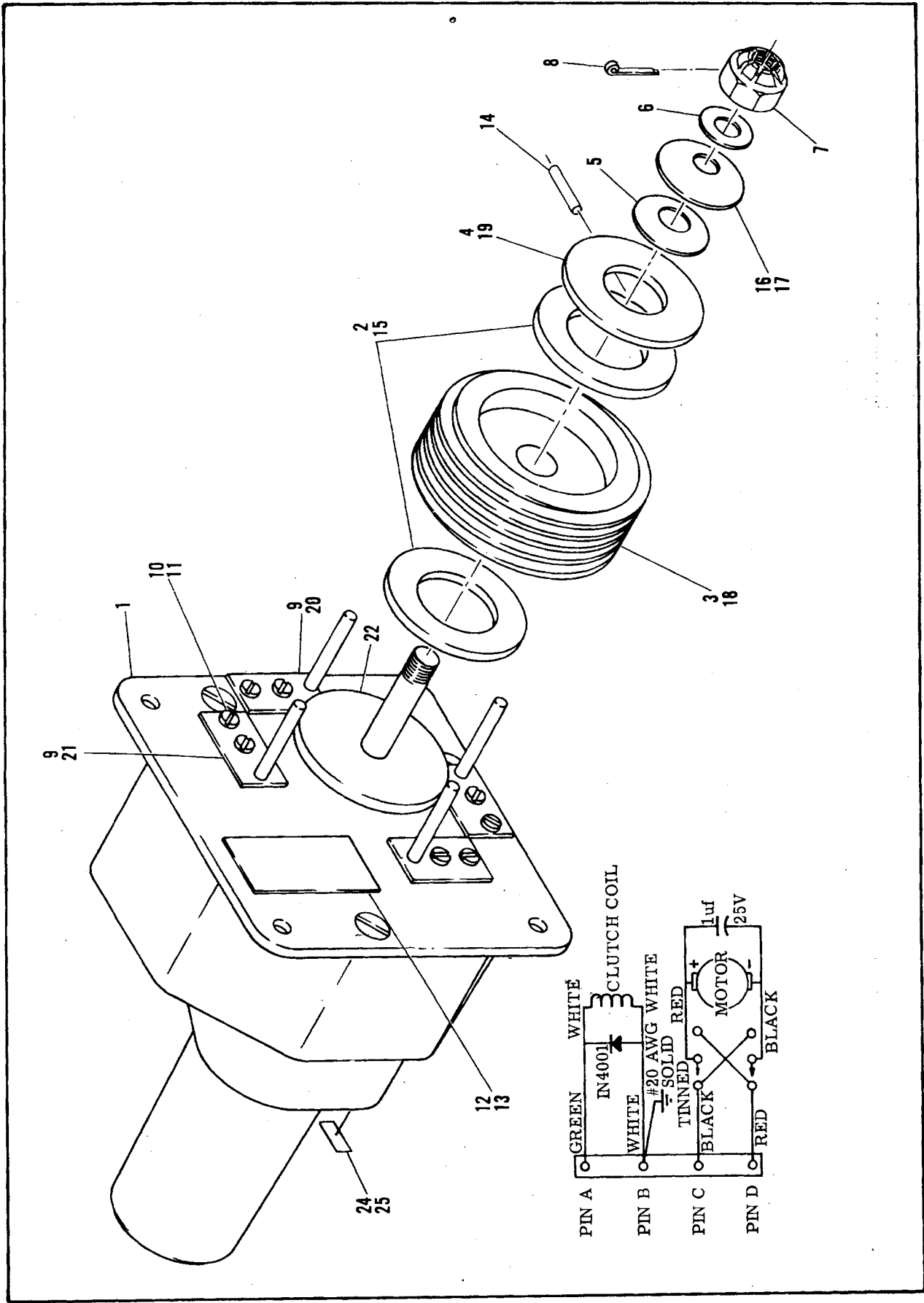

IC363-1 Servo, 14 VDC, 7.2 RPM

1C363-1 - SERVO ASSEMBLY 14VDC, 7.2 RPM

ITEM NO.	PART NO.	DESCRIPTION
-1	1B484	SERVO ACTUATOR, 12VDC, Globe No. 67A243-1
-2	4A181 *	CLUTCH DISC
-3	49A28-1 *	CAPSTAN ASSEMBLY
-4	4A179 *	WASHER
-5	4A152	TENSION WASHER
-6	4S150	WASHER, 5/16 LD x 5/8 OD x .010 THK
-7	2S91	NUT, 5/16-24 NF, Castle, AN310-5.
-8	22S53	COTTER PIN, 1/16 x 3/4, AN380-2-3.
-9	7A508-1 *	CABLE GUARD (For positions No. 1, 2, 3, & 4)
-10	3S174	SCREW, B. H. No. 6-3ZUNC-2A x 1/4
-11	4S96	LOCKWASHER, Internal No. 6
-12	13A265-1	LABEL, Model No., S/N
-13	11M191	SOLVENT
-14	22S80	ROLL PIN, 5/64 x 1/2.
-15	4A181-1 +	CLUTCH DISC
-16	4A180 *	TENSION WASHER
-17	4A180-1 +	TENSION WASHER
-18	49A38-1 +	CAPSTAN ASSEMBLY
-19	4A179-1 +	WASHER
-20	7A701 +	CABLE GUARD (For positions No. 2 & No. 4)
-21	7A701-1 +	CABLE GUARD (For positions No. 1 & No. 3)
-22	4A186 +	PLATE
-23	49A28-4 *	CAPSTAN ASSEMBLY
-24	13A274	LABEL (CD-47)
-25	13A143	LABEL (CD-16)

* Used with large capstan

+ Used with small capstan

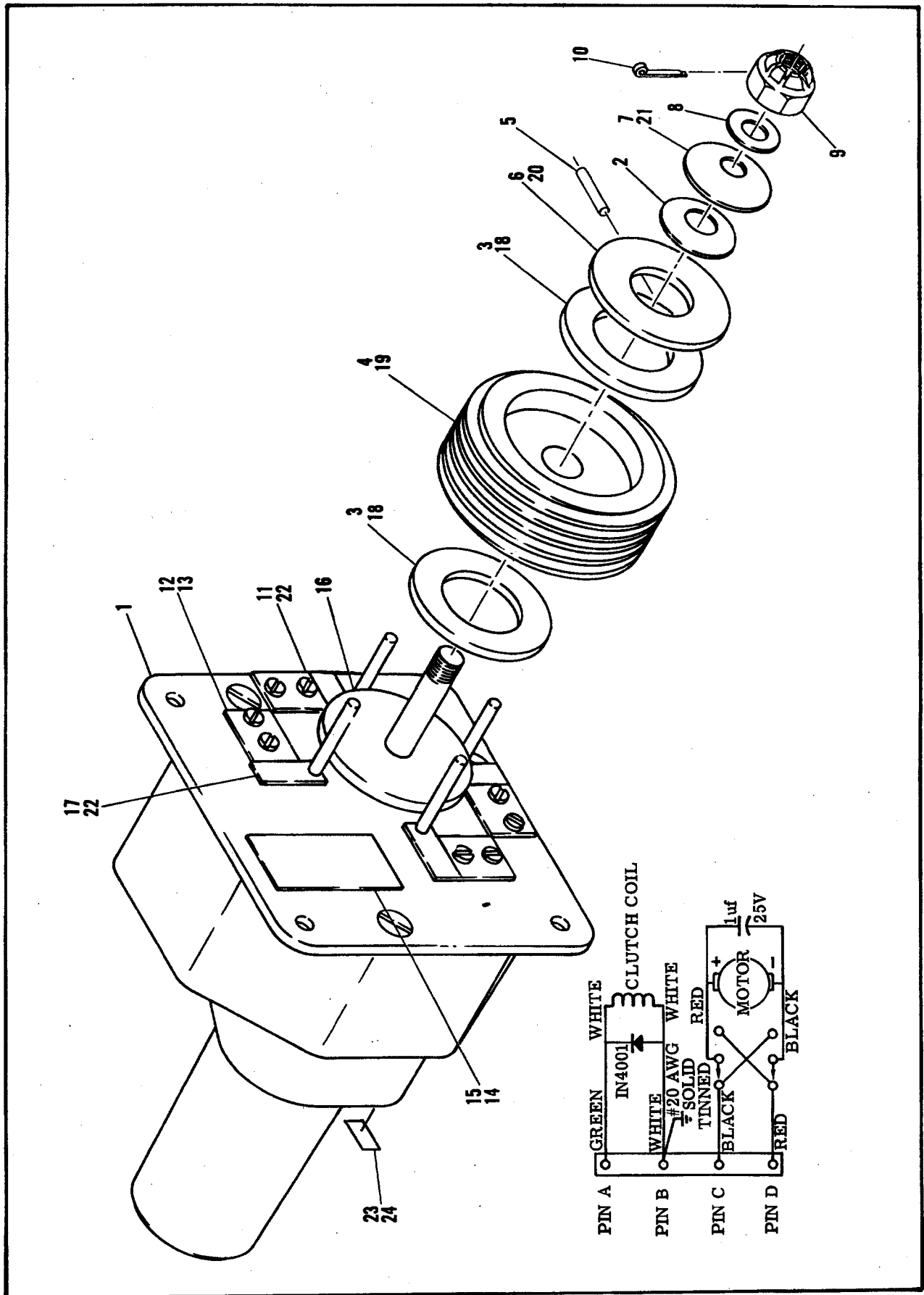

IC465-1 Servo, 28 VDC, 7.2 RPM

1C465-1- SERVO ASSEMBLY 28 VDC, 7.2 RPM

ITEM NO.	PART NO.	DESCRIPTION
-1	1B485	SERVO ACTUATOR, 24 VDC, Globe No. 67A244-1
-2	4A152	TENSION SPRING WASHER
-3	4A181-1 *	CLUTCH DISC
-4	49A38-1 *	CAPSTAN ASSEMBLY
-5	22S80	ROLL PIN, 5/64 x 1/2.
-6	4A179-1 *	WASHER, Slotted
-7	4A180-1 *	TENSION SPRING WASHER
-8	4S150	WASHER, 5/16 LD x 5/8 OD x .010 THK
-9	2S91	NUT, Castle, AN-310-3, 5/16-24 UNF-2B
-10	22S53	COTTER PIN, AN380-2-3, 1/16 x 3/4.
-11	7A701 *	CABLE GUARD (Position NO. 20R No.4)
-12	3S174	SCREW, B. H. , No. 6-32 UNC-2A x 1/4
-13	4S96	LOCKWASHER, Internal, No. 6
-14	13A265-1	LABEL, Model No. S/N
-15	11M191	SOLVENT
-16	4A186 *	PLATE.
-17	7A701-1 *	CABLE GUARD (Position No. 1 or No. 3)
-18	4A181 +	CLUTCH DISC
-19	49A28-1 +	CAPSTAN ASSEMBLY
-20	4A179 +	WASHER.
-21	4A180 +	TENSION SPRING WASHER
-22	7A508-1 +	CABLE GUARD (Position No. 1, 2, 3 or 4).
-23	13A274	LABEL (CD-47)
-24	13A143	LABEL (CD-16)

* Used with large capstan

+ Used with small capstan

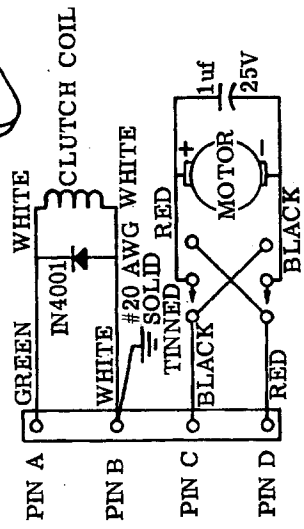
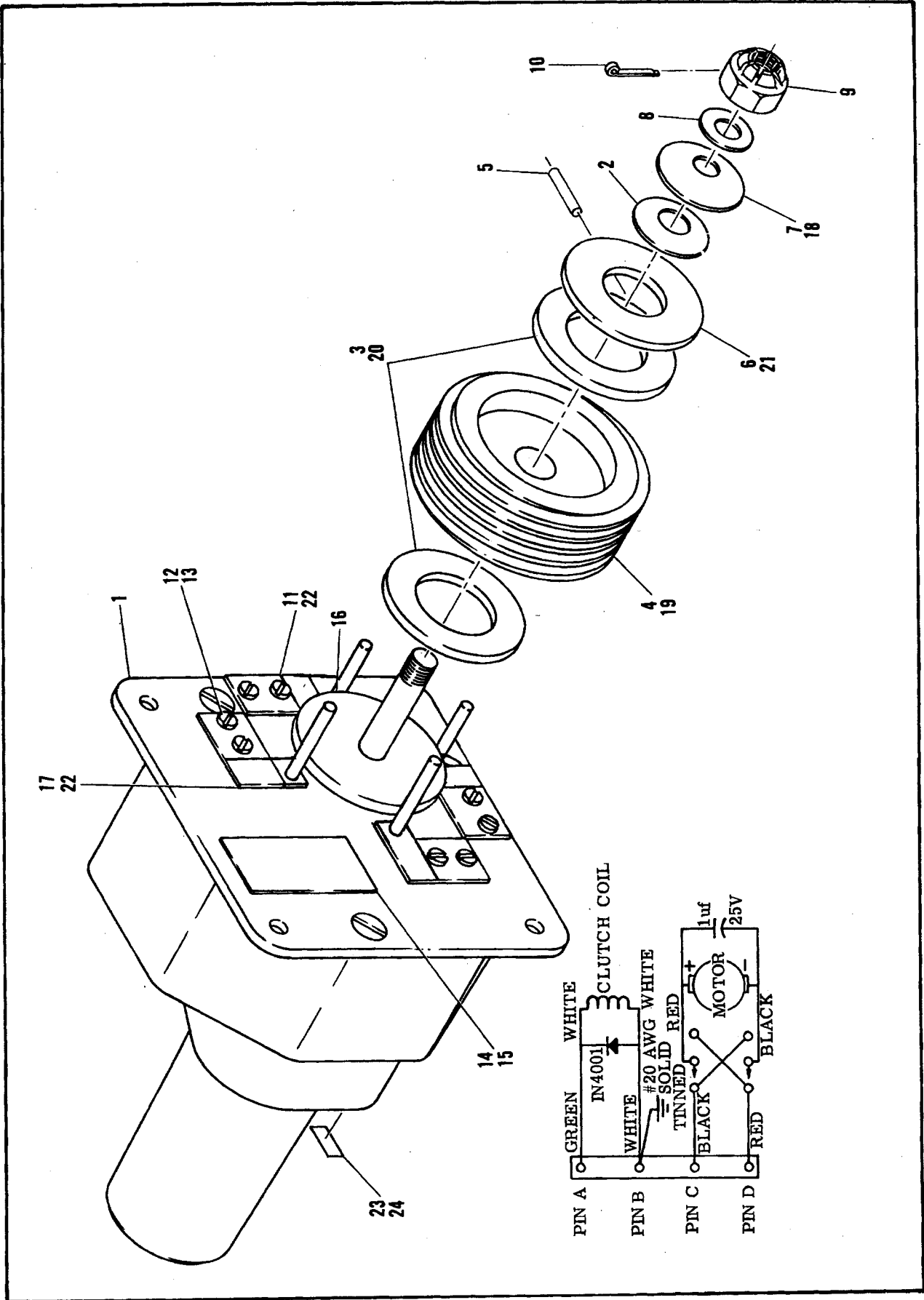

1C470-1 Servo, 28 VDC, 1.8 RPM

1C470-1- SERVO ASSEMBLY, 28VDC, 1.8 RPM

ITEM NO.	PART NO.	DESCRIPTION
-1	1B485-1	SERVO ACTUATOR, 24 VDC, Globe No. 67A244-2
-2	4A152	TENSION SPRING WASHER
-3	4A181-1	* CLUTCH DISC
-4	49A38-1	* CAPSTAN ASSEMBLY
-5	22S80	ROLL PIN, 5/64 x 1/2.
-6	4A179-1	* WASHER, Slotted
-7	4A180-1	* TENSION SPRING WASHER
-8	4S150	WASHER, 5/16 LD x 5/8 OD x .010 THK
-9	2S91	NUT, Castle, AN310-5, 5/16-24 UNF-2B.
-10	22S53	COTTER PIN, AN310-2-3, 1/16 x 3/4.
-11	7A701	* CABLE GUARD (For positions No. 2 & No. 4)
-12	3S174	SCREW, B. H. , No. 6-32 UNC-2A x 1/4
-13	4S96	LOCKWASHER, Internal No. 6
-14	13A265-1	LABEL, Model No. S. N.
-15	11M191	SOLVENT
-16	4A186	* PLATE
-17	7A701-1	* CABLE GUARD (For positions No. 1 & No. 3)
-18	4A180	+ TENSION SPRING WASHER
-19	49A28-1	+ CAPSTAN ASSEMBLY
-20	4A181	+ CLUTCH DISC
-21	4A179	+ WASHER.
-22	7A508-1	+ CABLE GUARD (For positions No. 1, 2, 3 & 4)
-23	13A274	LABEL (CD-47)
-24	13A143	LABEL (CD-16)

* Used for large capstan

+ Used with small capstan

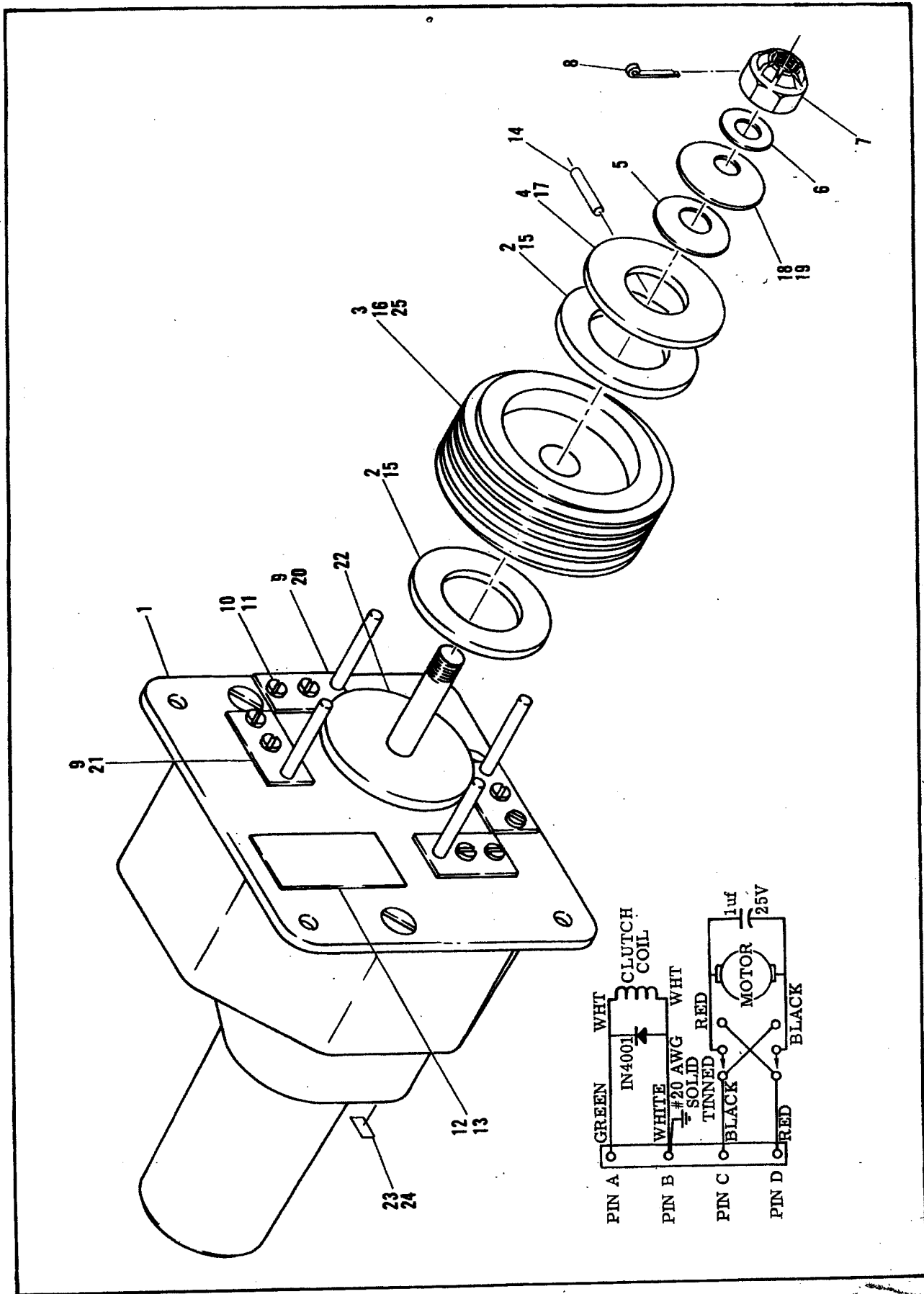

1C508-1 Servo, 14 VDC, 1.8 RPM

1C508-1 - SERVO ASSEMBLY, 14VDC, 1.8 RPM

ITEM NO.	PART NO.	DESCRIPTION
-1	1B484-1	SERVO ACTUATOR, 12VDC, Globe No. 67A243-2
-2	4A181 *	CLUTCH DISC
-3	49A28-1 *	CAPSTAN ASSEMBLY
-4	4A179 *	WASHER
-5	4A152 *	TENSION WASHER
-6	4S150	WASHER, 5/16 LD x 5/8 OD x .010 THK
-7	2S91	NUT, 5/16-24 NF, Castle, AN310-5.
-8	22S53	COTTER PIN, 1/16 x 3/4, AN380-2-3.
-9	7A508-1 *	CABLE GUARD (For positions No. 1, 2, 3, & 4)
-10	3S174	SCREW, B. H. NO. 6-32 NC-2A x 1/4.
-11	4S96	LOCKWASHER, Internal No. 6
-12	13A265-1	LABEL, Model No., S/N
-13	11M191	SOLVENT
-14	22S80	ROLL PIN, 5/64 x 1/2.
-15	4A181-1 +	CLUTCH DISC
-16	49A38-1 +	CAPSTAN ASSEMBLY
-17	4A179-1 +	WASHER, Slotted
-18	4A180 *	TENSION WASHER
-19	4A180-1 +	TENSION WASHER
-20	7A701 +	CABLE GUARD (For positions No. 2 & No. 4)
-21	7A701-1 +	CABLE GUARD (For positions No. 1 & No. 3)
-22	4A186 +	PLATE.
-23	13A274	LABEL (CD-47)
-24	13A143	LABEL (CD-16)
-25	49A28-4 *	CAPSTAN ASSEMBLY

* Used with large capstan

+ Used with small capstan

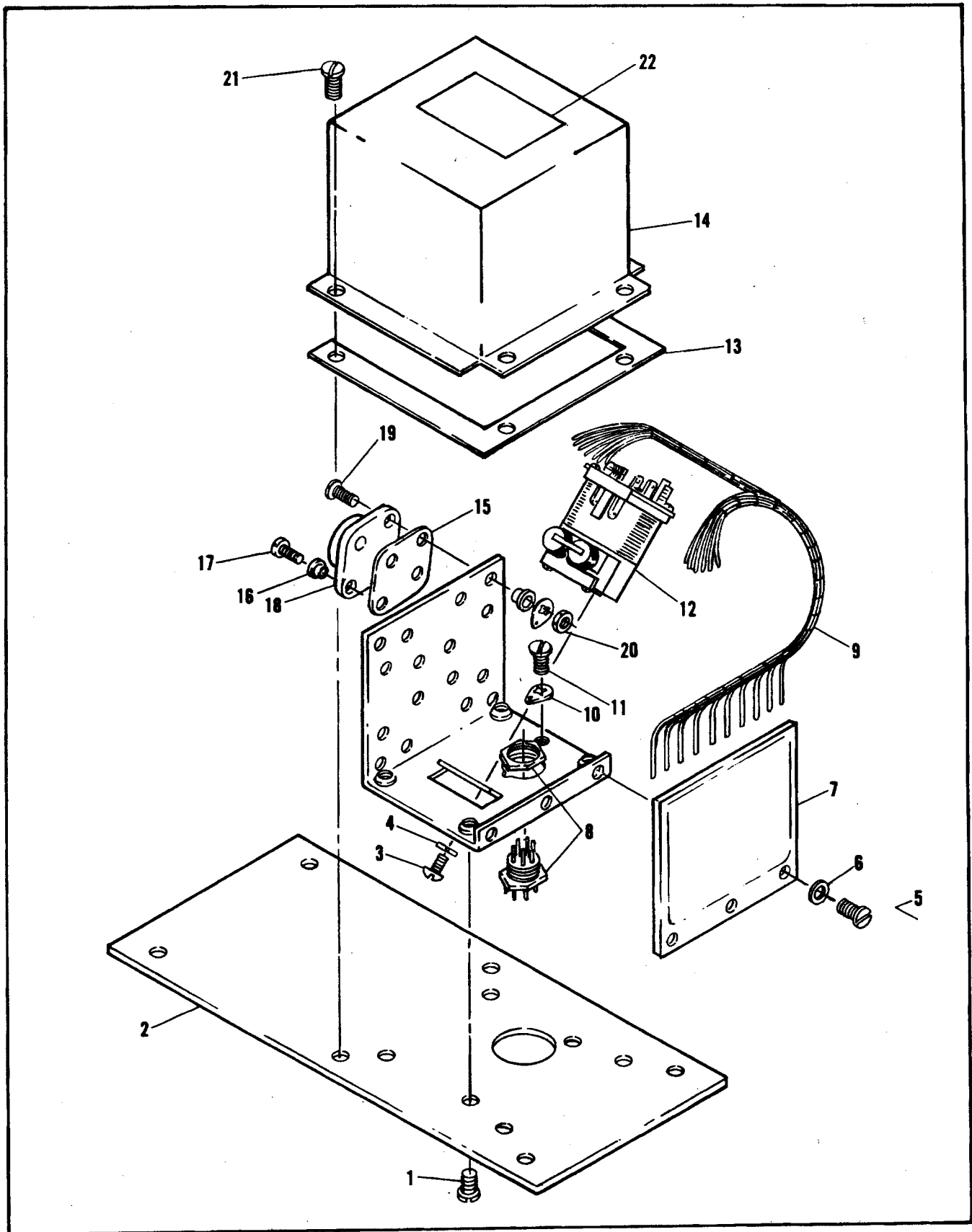

1C359 Gyro-Amplifier

1C359 - GYRO - AMPLIFIER
(Used in Stabilizer Back System)

ITEM NO.	PART NO.	DESCRIPTION
-1	3S298	SCREW 6-32 x 3/8 B. H.
-2	7B495	MOUNTING BRACKET
-3	3S36	SCREW 6-32 x 5/16 B. H.
-4	4S96	LOCKWASHER
-5	3S48	SCREW 4-40 x 3/16 B. H.
-6	4S40	LOCKWASHER No. 4 Int. Lock
-7	1C354	CIRCUIT BOARD ASSEMBLY (Ref.)
-8	28S53	PLUG ASSEMBLY 9 Pin
-9	30B185	ELECTRICAL HARNESS (Ref.)
-10	29S56	SOLDER LUG No. 4 Locking
-11	3S55	SCREW 4-40 x 1/8 R. H.
-12	1D350	RATE GYRO ASSY. (Ref. 69D471)
-13	32A15	GASKET
-14	15B169	COVER
-15	14A46	MICA INSULATOR
-16	4A58	INSULATOR WASHER
-17	3S164	SCREW 4-40 x 5/16 B. H.
-18	48S43	TRANSISTOR
-19	3S212	SCREW 4-40 x 1/2 B. H.
-20	2S14	NUT 4-40 Hex
-21	3S280	SCREW 4-40 x 3/16 B. H.
-22	13A265	LABEL

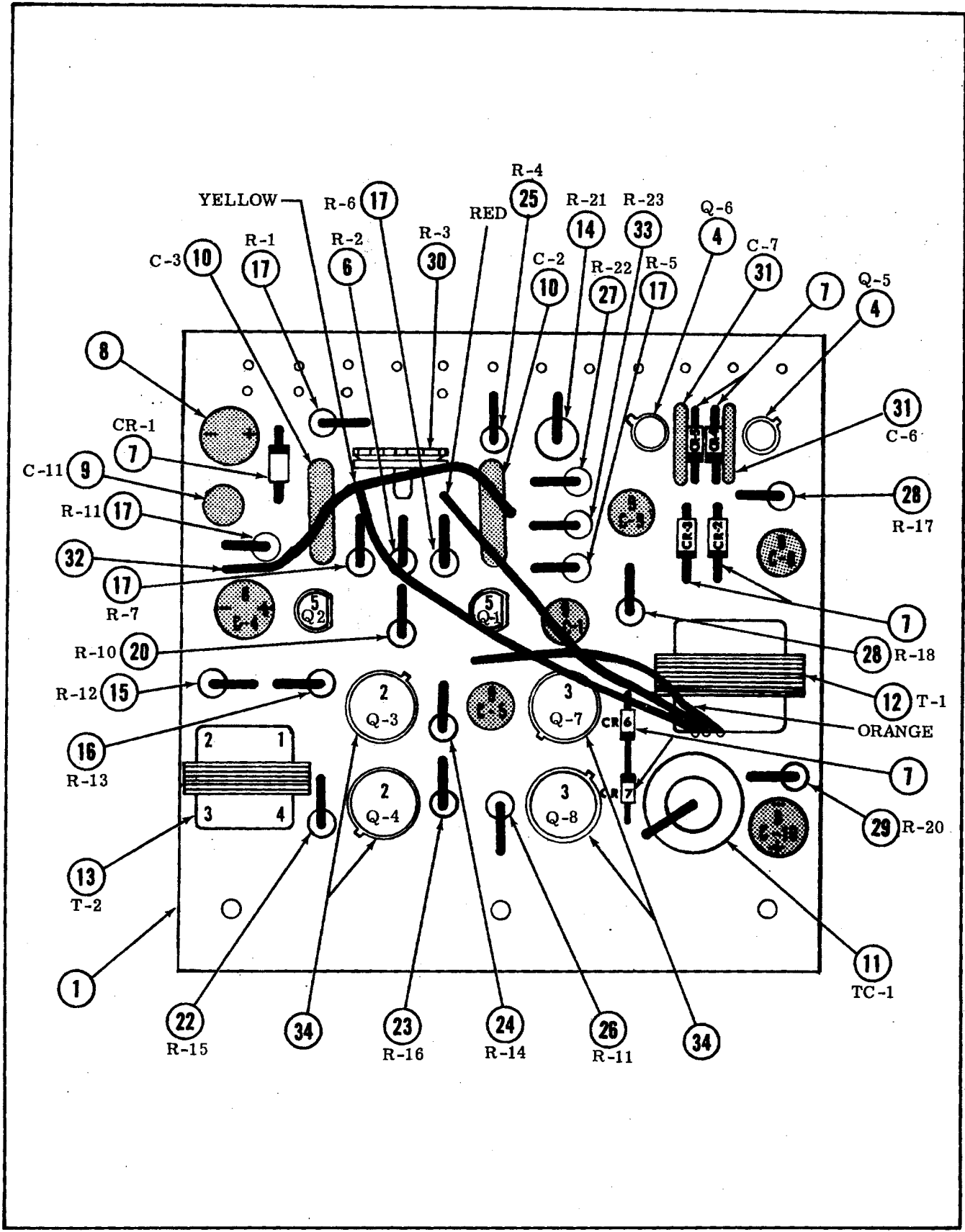

1C354 Printed Circuit Board Assembly

**1C354 - PRINTED CIRCUIT BOARD ASSEMBLY
(STABILIZER)**

ITEM NO.	PART NO.	DESCRIPTION
-1	27B79	PRINTED CIRCUIT BOARD
-2	48S35	TRANSISTOR MA900-1
-3	48S31	TRANSISTOR ZN1194
-4	48S42	TRANSISTOR 2N 3116
-5	48S49	TRANSISTOR MPS 6515
-6	6R115	RESISTOR, 47 OK 1/2W ± 10%
-7	48S33	DIODE IN4001
-8	21A45	CAPACITOR, 35 uf, Polarized
-9	21A44	CAPACITOR, 5 uf, Non-polarized
-10	8S14	CAPACITOR, 1 mfd.
-11	24A93	CIRCUIT, Tuned
-12	25B31	TRANSFORMER
-13	25A23	TRANSFORMER
-14	6R75	RESISTOR, .47 Ohm, 1W, 10%
-15	6R84	RESISTOR, 68K, 1/2W, 10%
-16	6R117	RESISTOR, 6.2K, 1/2W, 10%
-17	6R31	RESISTOR, 10K, 1/2W, 10%
-18	6R118	RESISTOR, 4.7K, 1/2W, 10%
-19	6R87	RESISTOR, 1K, 1/2W, 10%
-20	6R72	RESISTOR, 100K, 1/2W, 10%
-21	6R97	RESISTOR, 270 Ohm, 1/2W, 10%
-22	6R116	RESISTOR, 1M, 1/2W, 10%
-23	6R115	RESISTOR, 470K, 1/2W, 10%
-24	6R77	RESISTOR, 100 Ohm, 1/2W, 10%
-25	6R133	RESISTOR, 3.3K, 1/2W, 5%
-26	6R101	RESISTOR, 33 Ohm, 1/2W, 10%.
-27	18S16	POTENTIOMETER, 10K.
-28	8S14	CAPACITOR, 1.0 uf
-29	10M128	NO. 26 Plastic Jacketed Wire (Alpha No. 1687)
-30	6R91	RESISTOR, 1.2K, 1/2W, 10%
-31	14S151	TRANSISTOR MOUNTING PAD

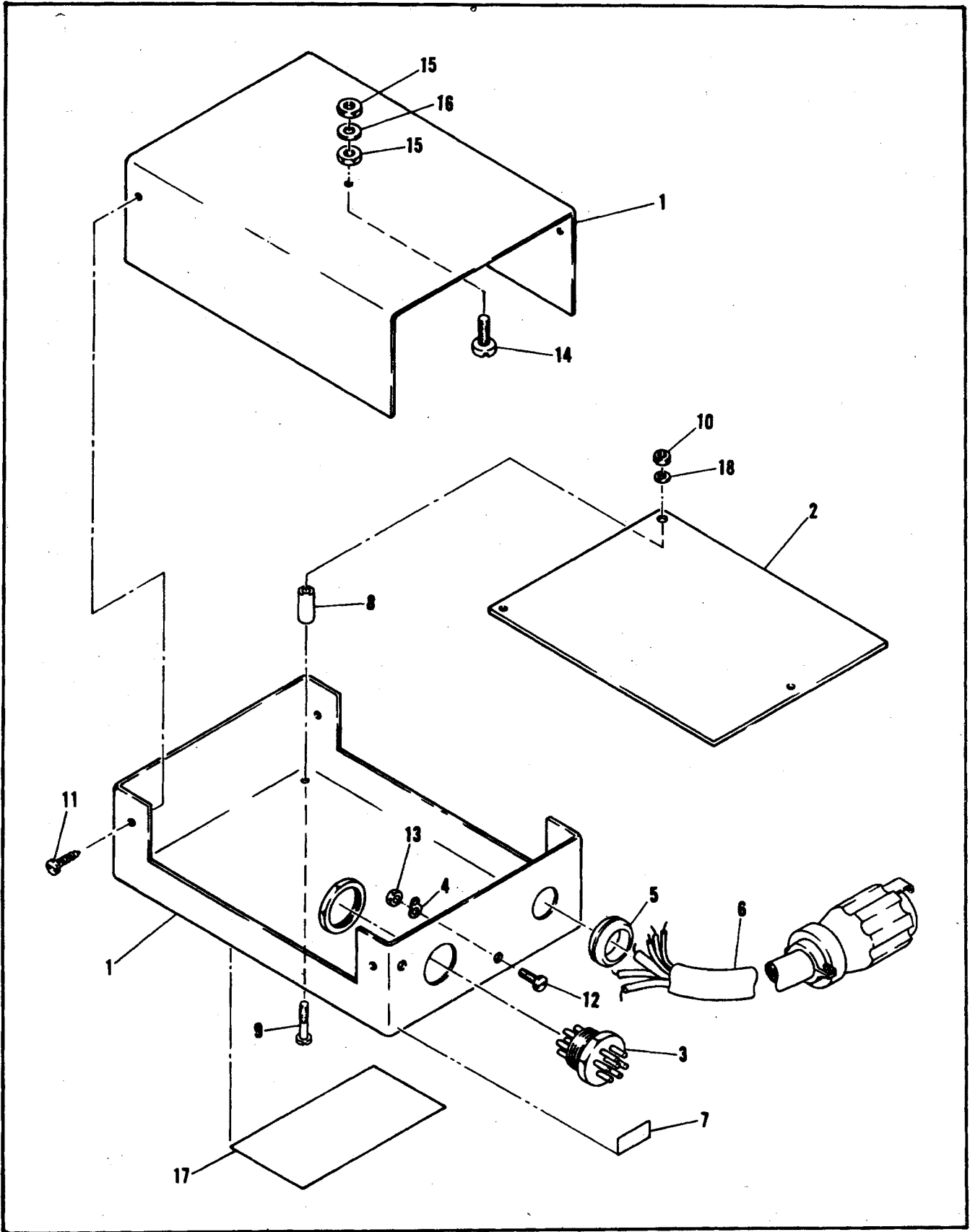

1B440 Roll Signal Filter

1B440 - ROLL SIGNAL FILTER

ITEM NO.	PART NO.	DESCRIPTION
-1	15B193	HOUSING & COVER
-2	1B441	ASSY. PRINTED CIRCUIT BOARD
-3	28S50	CONNECTOR, 7 pin
-4	29S21	LUG, No. 4 Int. Lock
-5	5S59	GROMMET
-6	30B248	CABLE ASSEMBLY
-7	13A145	LABEL, CD-18
-8	43A321	STANDOFF.
-9	3S54	SCREW, 2-56 x 7/16 B. H.
-10	2S46	NUT, 2-56 Hex
-11	COMM	SCREW, No. 6 Sheet Metal x 1/4 B. H.
-12	3S48	SCREW, 4-40 x 3/16 B. H.
-13	2S14	NUT, 4-40 Hex
-14	3S228	SCREW, 6-32 x 1/2 B. H..
-15	2S17	NUT, 6-32 Hex
-16	4S96	WASHER, No. 6, Int. Lock
-17	13A265	PLACARD
-18	4S16	WASHER, No. 2, Int. Lock

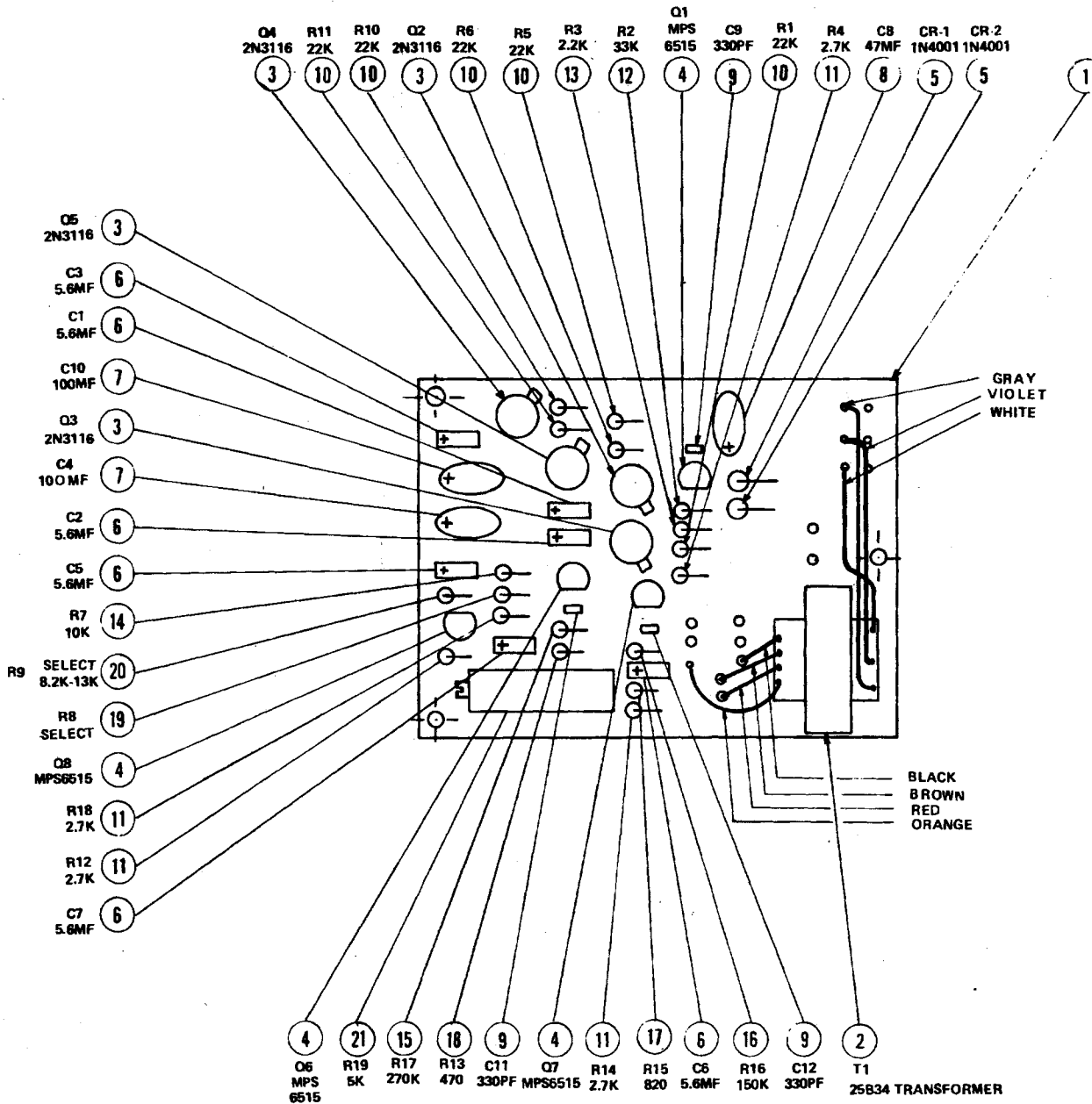

PITCH SIGNAL FILTER
CIRCUIT BOARD

PRINTED CIRCUIT BOARD ASSEMBLY PITCH SIGNAL FILTER - 1B440-1

ITEM NO.	PART NO.	DESCRIPTION
-1	27B107-1	PRINTED CIRCUIT BOARD
-2	25B34	TRANSFORMER
-3	48S42	TRANSISTOR, 2N3116
-4	48S49	TRANSISTOR, MPS 6515
-5	48S33	DIODE, IN4001
-6	21S85	CAPACITOR, 5.6MF, 20V, TANTALUM
-7	21S116	CAPACITOR, 100MF, 20V., TANTALUM
-8	21S139	CAPACITOR, 47MF, 20V., TANTALUM
-9	21S101	CAPACITOR, 330PF
-10	6322324	RESISTOR, 22K, 1/4W, 2%
-11	6327224	RESISTOR, 2.7K, 1/4W, 2%
-12	6333324	RESISTOR, 33K, 1/4W, 2%
-13	6322224	RESISTOR, 2.2K, 1/4W, 2%
-14	6310324	RESISTOR, 10K, 1/4W, 2%
-15	6327424	RESISTOR, 270K, 1/4W, 2%
-16	6315424	RESISTOR, 150K, 1/4W, 2%
-17	6382124	RESISTOR, 820 OHM, 1/4W, 2%
-18	6347124	RESISTOR, 470 OHM, 1/4W, 2%
-19	SELECT	RESISTOR, 68K-150K, 1/4W, 2%
-20	SELECT	RESISTOR, 8.2K-13K, 1/4W, 2%
-21	18S32	TRIMPOT 5K

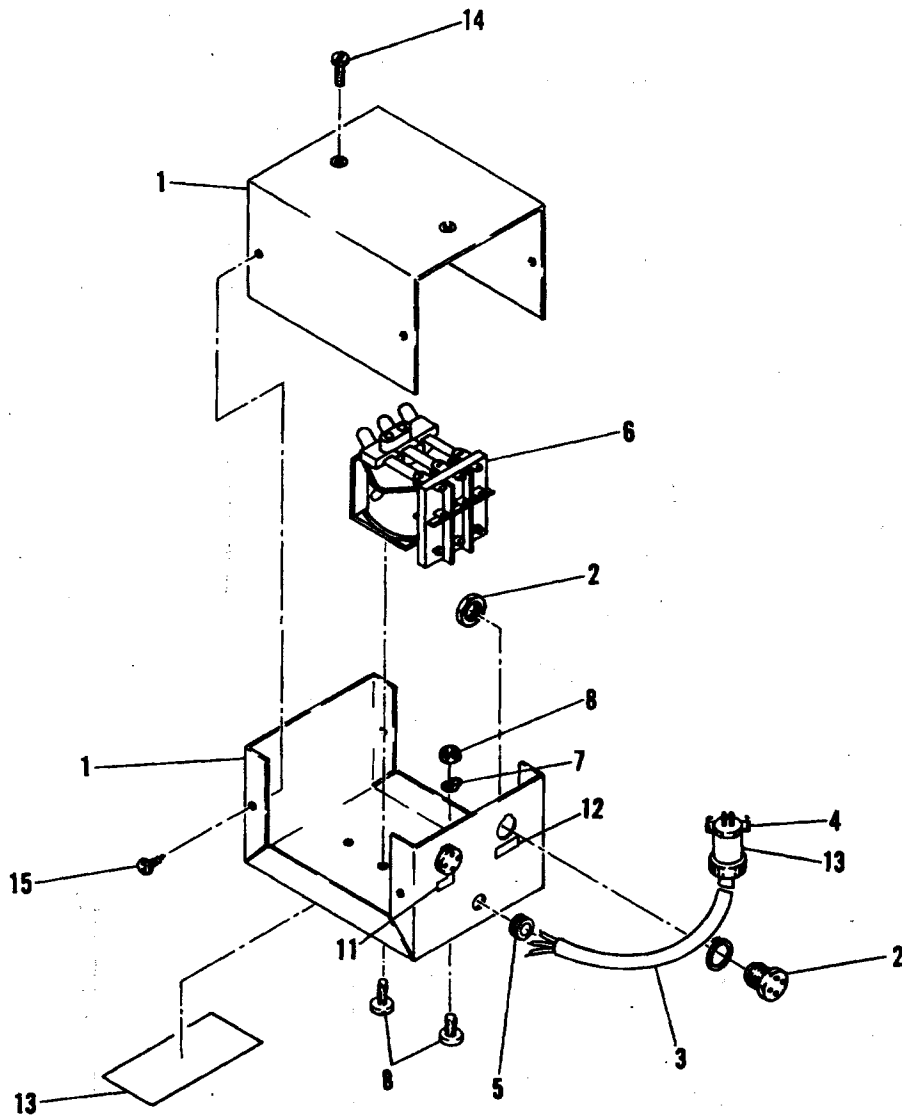

1B405 Switch Box

1B405 - SWITCH BOX

ITEM NO.	PART NO.	DESCRIPTION
-1	15B187	HOUSING & COVER
-2	9S68	RECEPTACLE (4 Pin)
-3	30S51	CABLE
-4	28S40	PLUG (4 pin)
-5	5S59	GROMMET
-6	*80S12	RELAY 3 PDT.
-7	29S44	SOLDER LUG
-8	3S174	SCREW 6-32 x 1/4 B. H.
-9	2S17	NUT 6-32 Hex
-10	13A274	LABEL CD-47
-11	13A318	LABEL STAB
-12	13A319	LABEL AUTOPILOT
-13	13A265	LABEL S/N
-14	3S298	SCREW 6-32 x 7/8 B. H.
-15	3S37	SCREW No. 4 x 1/4 B. H. sm.

* NOTE: For 1B405-24 Switch Box replace 80S12 relay with 80S14.

REV.	DESCRIPTION	DATE
1	RELEASED PER L.S. 2011	11/25/76
2	REVISION	11/25/76

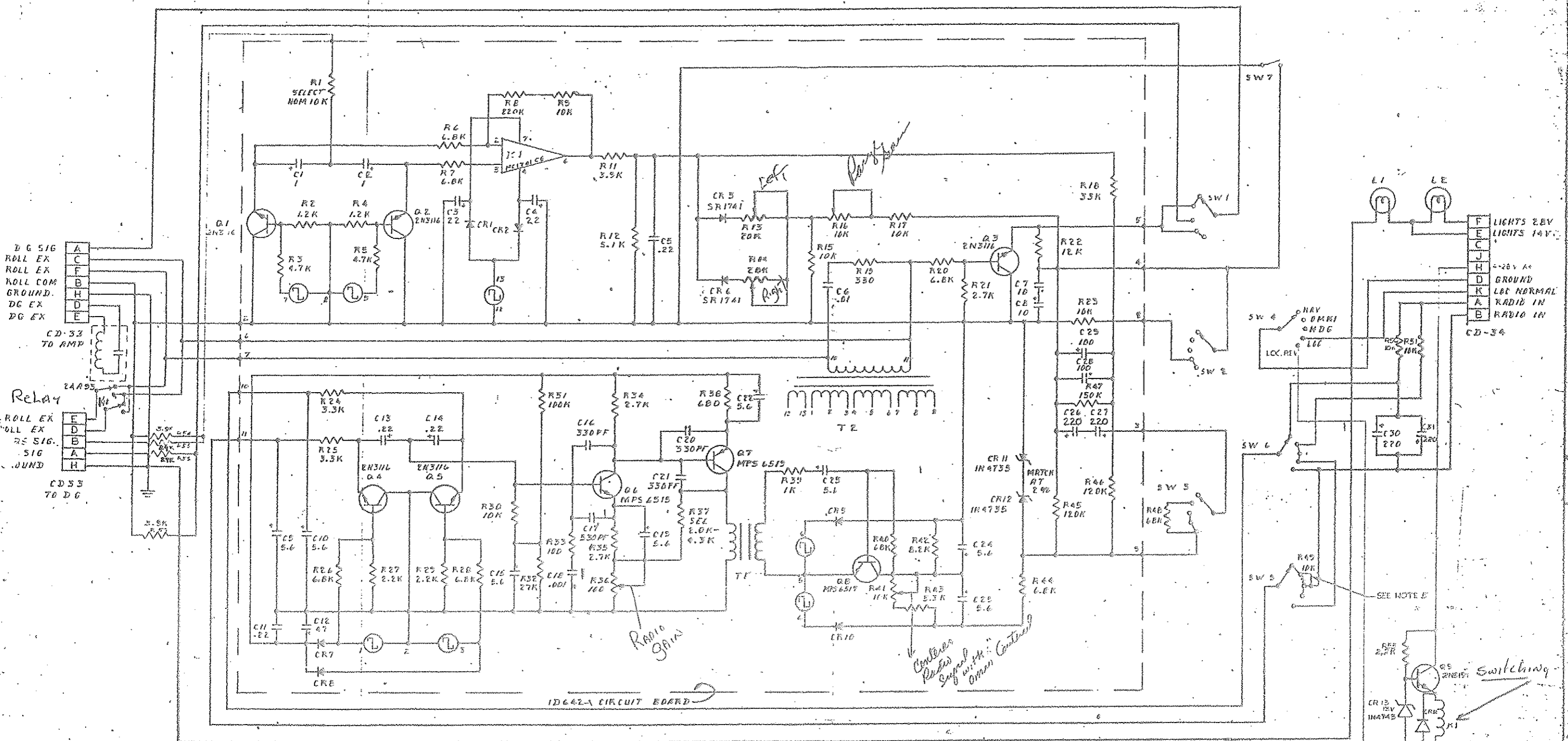

- NOTES:**
1. ALL CAPACITORS ARE IN UF UNLESS OTHERWISE SPECIFIED.
 2. ALL RESISTORS ARE IN OHMS UNLESS OTHERWISE SPECIFIED.
 3. ALL RESISTORS ARE 1/2 WATT UNLESS OTHERWISE SPECIFIED.
 4. ALL DIODES ARE IN 400V UNLESS OTHERWISE SPECIFIED.
 5. JUMPER ACROSS R49 TO BE REMOVED WHEN USED WITH ORN1 CONVERTERS WITH ARINC OUTPUT - 10° = 150 MILLIVOLTS.

USED WITH NSD-360 SYS.

QTY	ITEM	PART NUMBER	DESCRIPTION
LIST OF MATERIALS			
			MITCHELL INDUSTRIES, INC.
			MINERAL WELLS, TEXAS
			SCHEMATIC, RADIO COUPLER IC388-2
			NO. 3303

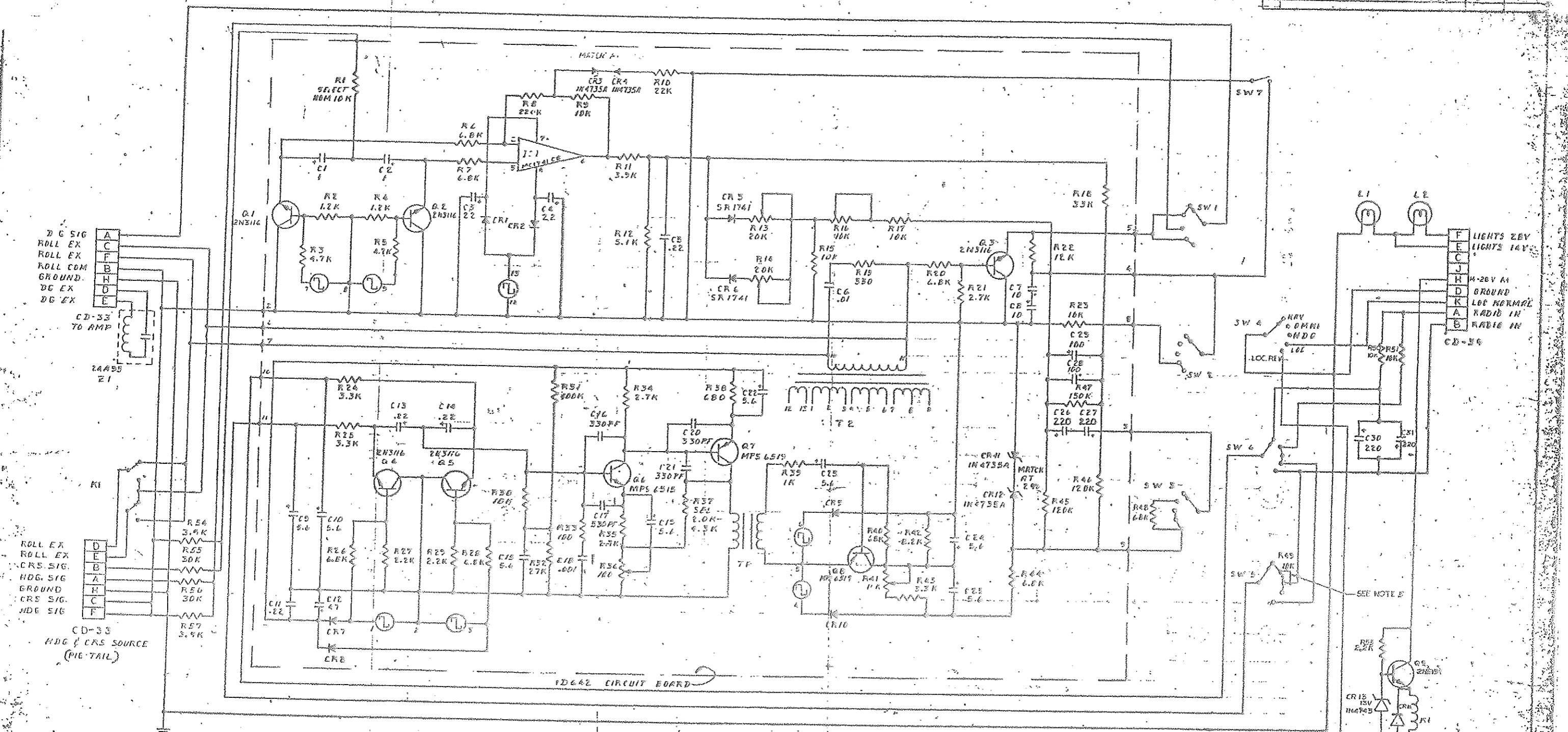

- NOTES:
1. ALL CAPACITORS ARE IN UF UNLESS OTHERWISE SPECIFIED.
 2. ALL RESISTORS ARE IN OHMS UNLESS OTHERWISE SPECIFIED.
 3. ALL RESISTORS ARE 1/4 WATT UNLESS OTHERWISE SPECIFIED.
 4. ALL DIODES ARE IN ADDI UNLESS OTHERWISE SPECIFIED.
 5. JUMPER ACROSS R49 TO BE REMOVED WHEN USED WITH OMNI CONVERTERS WITH ARINC OUTPUT - 10" = 150 MILLIVOLTS.

Collins PNIOL
 Heading & CRS SW
 USED NEWER VERSION OF MC

KT									
L2									
R57									
C32									
Z									
CR1									
CR2									
CR3									
CR4									
CR5									
CR6									
CR7									
CR8									
CR9									
CR10									
CR11									
CR12									
CR13									
CR14									
CR15									
CR16									
CR17									
CR18									
CR19									
CR20									
CR21									
CR22									
CR23									
CR24									
CR25									
CR26									
CR27									
CR28									
CR29									
CR30									
CR31									
CR32									
CR33									
CR34									
CR35									
CR36									
CR37									
CR38									
CR39									
CR40									
CR41									
CR42									
CR43									
CR44									
CR45									
CR46									
CR47									
CR48									
CR49									
CR50									
CR51									
CR52									
CR53									
CR54									
CR55									
CR56									
CR57									
CR58									
CR59									
CR60									
CR61									
CR62									
CR63									
CR64									
CR65									
CR66									
CR67									
CR68									
CR69									
CR70									
CR71									
CR72									
CR73									
CR74									
CR75									
CR76									
CR77									
CR78									
CR79									
CR80									
CR81									
CR82									
CR83									
CR84									
CR85									
CR86									
CR87									
CR88									
CR89									
CR90									
CR91									
CR92									
CR93									
CR94									
CR95									
CR96									
CR97									
CR98									
CR99									
CR100									

MITCHELL INDUSTRIES, INC.
 MINERAL WELLS, TEXAS
 SCHEMATIC, RADIO
 COUPLER IC388-3
 63D357