

HOW TO FLY AIRPLANES

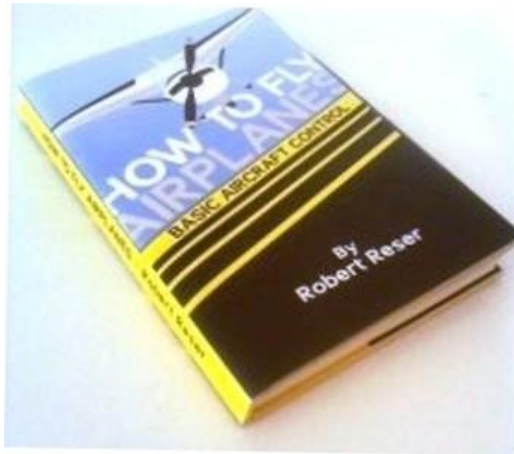

Available through <http://safe-flight.net>

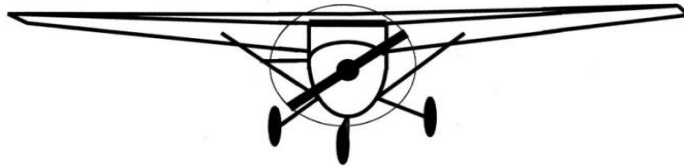

HOW TO FLY AIRPLANES



BASIC AIRCRAFT CONTROL

Robert Reser, Publisher
bob@safe-flight.net
Tempe, Arizona

Copyright 2012-2015 by Robert Reser

All rights reserved.

Copyright laws of the United States and International treaties protect this book.

This book is intended as a supplement to usual initial flight instruction. No content supersedes official FAA procedures or regulations.

There are some changed procedures and techniques of flight control from those normally taught. Robert Reser assumes no responsibility for errors or omissions or liability for use of this information.

Reproduction of this book, not to be sold, is allowed for individual or classroom use if printed with this copyright notice.

Printed in United States of America

ISBN-13: 978-0-9886249-1-7

Revised Edition

Go to... <http://safe-flight.net>

CONTENTS

CONTENTS	I
DIAGRAMS	VI
PREFACE	VII
INTRODUCTION	VIII
Let's Review Real Life	viii
Real Life Flight	ix
CHAPTER 1-----PRINCIPLES OF FLIGHT	1
Flight	1
Flight Forces	1
Force Vectors	3
Component-Forces	5
V-Speeds	6
Aerodynamic Lift—Newton and Bernoulli/Coanda	7
Aerodynamic Lift	8
Angle-of-Attack	11
Aircraft Balance	13
Moment, Moment Arms, and Torque	13
Center of Pressure—Point of Balance	15
Energy and Energy Sources	16
Thrust	17
Gravity Component-Thrust for Sustaining Lift	17
Engine Thrust Component-Lift	18
Engine Performance	18
Thrust Available	19
Thrust Required	20
Gravity	21
Gravity Component-Thrust	22
Drag Forces	22
Aircraft Attitude Effective Axes	23
Dimensional Axes	24
Stability	25
Minimum Safe Indicated-Airspeed Flight and Descents	25
“g” Forces/Load Factor	26
Glide	27
Indicated-Airspeed	27
True Airspeed and Groundspeed	28
Lift Pressure and Wing Loading	29
Ground-effect	30
Estimating Wind Components	31
CHAPTER 2-----FLIGHT MANEUVERING	33
How Does An Airplane Fly?	33
Control	33
Transfer Of Energy (Energy Management)	34
Now What Is Going To Happen?	35
Flight Controls	35
Ailerons	36
Rudder	37
Elevator	37
Elevator and Horizontal Stabilizer Trim	38
Throttle and Mixture Control	39

Engine Mounting and Control	39
Engine Thrust Components (tractor-engine).....	40
Maneuvering.....	41
Flap Configuration.....	42
Attitude	42
Pitch.....	43
Pitch Angle	43
Pitch Control	44
Elevator-Pitch.....	44
Rudder-Pitch	44
Descent-Pitch	45
Maneuvering is Attitude Change.....	45
Maneuvering in Level Flight.....	45
Maneuvering with Excess Thrust (turns).....	46
Maneuvering with Excess Thrust (Climb).....	48
Maneuvering in Descending Flight.....	48
Maneuvering with Gravity (Engine Out)	49
Gravity Effects.....	50
Zoom and Dive	50
CHAPTER 3-----VISUAL FLIGHT CONTROL	53
“Directed-Course” Visual Flight Control	53
Vertical Pitch Attitude.....	55
Visual Flight Attitudes	55
Takeoff Attitude.....	56
Climb Attitude	56
Cruise Attitude.....	57
Turn Attitude	57
Descent attitude.....	58
Approach Descent Attitude	60
Roundout Attitude.....	61
Flare Attitude.....	61
Landing/Ground Roll	62
Collision Course.....	62
CHAPTER 4-----VISUAL APPROACH AND GO-AROUND	65
Descent Maneuvering	65
Approach Maneuvering Slow Flight.....	66
Base Leg to Final Approach	67
Base Leg to Final Turn Overshoot	67
Visual Approach.....	70
The Normal Approach.....	71
Idle-Power Approach.....	72
Straight-in Idle-Power Approaches.....	74
Crosswind Landing Approach.....	75
Approach Over an Obstacle	76
Ground-Effect.....	76
The Go-Around.....	77
Preparing for Go-Around	77
Initiating a Go-Around	77
Go-Around Situation.....	78
Go-Around Procedure	78
When to Go-Around	79
Go-Around at or After Touchdown	80
The Mindset	80

CHAPTER 5-----TAKEOFFS.....	81
Taxi.....	81
Normal Takeoff	81
Crosswind Takeoff.....	82
Short-Field Takeoff.....	83
Soft-Field/Rough-Field Takeoff	83
Obstacle Clearing Takeoff.....	83
CHAPTER 6-----LANDINGS	85
Considerations	85
Accuracy of the Landing Point.....	85
Forward-Slip.....	85
Side Slip.....	86
Roundout and Flare	86
Landing	86
Normal Landings	87
Touchdown	87
Soft-Field Landing	88
Short-Field Landing	88
Landing over an obstacle.....	89
Crosswind Landings.....	89
Crosswind Landing Touchdown	90
Crosswind Landing Control	90
Crosswind Landing Rollout	91
Crosswind and Tailwind Landing Considerations	91
Extreme Crosswind Landing Situations	92
Emergency Crosswind Landing.....	92
High Wind Taxi Operations	93
Landing With One Brake Inoperative	93
CHAPTER 7-----HIGH ALTITUDE FLIGHT AND THE ATMOSPHERE	95
High-Altitude Flight	95
Atmosphere	95
Motion through the Atmosphere.....	96
Air Density and Your Aircraft	96
Air Density and the Engine	97
Air Density and the Airport.....	98
Air Density and You!	98
High Density Atmosphere.....	98
Engine Power and Engine Power Rating	99
Engine Fuel/Air-Induction	99
Small Aircraft Thrust Performance.....	100
CHAPTER 8-----STALLS.....	101
Stall	101
Elevator-Pitched Critical Angle-of-attack.....	101
Aircraft Pitch Control	102
What happens when reducing thrust?.....	103
Power Stall	104
Stalling	104
Stall Situations.....	105
Common Stall Scenarios	106
Elevator Trim Stall!	107
Accelerated and Secondary Stall	108
Disturbed Air Encounter	108

Upset	108
Microburst	109
Wake Turbulence and Avoidance	109
Practice Stalls.....	111
Stall Training.....	111
Stall Recovery.....	113
High-Altitude Stall High-Speed Recovery.....	114
CHAPTER 9-----EMERGENCY LANDINGS.....	117
Acceptance	117
Select a Site.....	117
Control the Aircraft	118
The Approach	118
Preparation for Off-field Landing	120
The Mental Anxiety.....	120
What is Experience?.....	120
Technique	122
Landing vs. Crashing	122
Continuing the Approach	123
Landing	123
Extreme Landing Surface.....	123
Landing on Relatively Smooth Surface.....	124
Touchdown	124
Landing Roll	125
Survival	125
Staying Conscious.....	125
Time.....	126
After Stopping	126
What do you think just happened?.....	127
Flight into IMC and Visual Disorientation.....	127
Take-off Load Shift.....	128
CHAPTER 10-----LET'S GO FLY.....	129
Purpose	129
Taxi for Takeoff	129
Takeoff Flight	130
Climbing Flight.....	131
Level Flight.....	132
Turning Flight	133
Maximum Performance Turn (wing-over)	133
Climb	134
Leveling from Climb.....	134
Descent	134
Leveling from Descent	135
Descending Flight to a Destination.....	135
Approach	136
Landing	136
Crosswind Landings.....	137
Emergency Landings	138
Loss of Visual Conditions—180-degree Turn.....	140
So, How Are Airplanes Controlled?.....	141
Indicated-Airspeed Control:.....	141
Acceleration and Deceleration:	141
Climb Control:	142
Directional Control:	142

Descent Control:	142
Landing Control:	142
All Flight:	143
APPENDIX-1-----PHYSIOLOGY OF MANUAL FLIGHT CONTROL	145
Stall	145
Trim	145
Perception.....	146
Avoiding Stall	147
APPENDIX-2-----RECIPROCATING ENGINES.....	149
Operating the Machine.....	149
Flight Preparation	149
Airplane Limitations.....	149
Power System	150
Ignition System	151
Engine Fuel Supply	151
Fuel/Air Mixture	151
Carburetor.....	152
Butterfly Valve.....	152
Mixture Control	152
Throttle	153
Accelerator Pump	153
Carburetor Ice	153
Carburetor Heat	154
Oil Temperature and Pressure.....	155
Engine Cranking and Starting	156
Ignition.....	156
Starting Fuel	156
Accelerator Pump	157
Engine Fire While Starting.....	158
Fuel Conditions for Starting.....	158
Conditions for Starting.....	158
Summary.....	159
GLOSSARY—INDEX	161

DIAGRAMS

Figure		Page
1-1	Aircraft Lift and Load in Wings Level climbing-----	2
1-2	Component-Vectors of Right Triangles -----	4
1-3	Vectors and Component-Vectors-----	5
1-4	V_y Airmass Encounter and Displacement Volume-----	8
1-5	Frontal-Plate Area -----	9
1-6	Frontal Area/Air Mass Displacement Area—Slow Flight--	10
1-7	Frontal Area/Air Mass Displacement Area—High Speed--	10
1-8	Angle-of-Attack-----	12
1-9	Moments, Moment Arms, and Torque-----	14
1-10	Engine and Aerodynamic Lift Forces-----	14
1-11	Balance-----	15
1-12	Thrust Component-Lift-----	18
1-13	Thrust for Idle Power Descent @ V_y -----	22
1-14	Drag and Component Drag Forces-----	23
1-15	Aircraft Axis, Three Dimensions of Rotation-----	24
1-16	Ground-Effect-----	31
1-17	Practical Uses of Vectors and Vector-Components-----	31
2-1	Small Aircraft Empennage-----	35
2-2	Aileron Control-----	36
2-3	Elevator Trim (pitch nose-up)-----	39
2-4	Engine Mounting Thrust Effect-----	40
2-5	Wing Flap Configuration-----	42
2-6	Which Way is Up?-----	43
2-7	Sustained Climbing Flight-----	46
2-8	Turns-----	47
2-9	Lift and Component Vertical and Horizontal Forces-----	48
3-1	“Directed-Course” Visual Flight, Cruise, Level -----	54
3-2	“Directed-Course” Visual Flight, Wings Level Climb-----	56
3-3	“Directed-Course” Visual Flight, 22-degree Level Turn-	58
3-4	Visual Descent to a Destination-----	59
3-5	“Directed-Course” Visual Descent to Destination-----	59
3-6	“Directed-Course” Visual Approach to Runway-----	60
3-7	Collision Course-----	63
4-1	Standard Left Hand Visual Traffic Pattern-----	65
4-2	Steep Banked Descending Turn to final-----	69
4-3	“Directed-Course” Visual Flight, Landing Approach-----	71
7-1	High-Altitude Turns-----	97
8-1	High-Altitude High Indicated-Airspeed Stall Recovery--	115
9-1	Engine Failure Landings-----	119

PREFACE

There has always been the argument that in flight, the more one knows about how and why the machine operates, the better or safer one can fly. It's hard to disagree, but when actually operating, it is too late to wonder how they built the thing. I have never heard of anyone worrying about that in flight.

Attempts at making flight safer by teaching the technical aspects of design theory have evolved over the past forty-fifty years. The typical manager and regulator have become more and more intellectually sophisticated. Their focus has been increased knowledge of why, but the airplane is still the same machine as always.

There is increased complexity of modern machines and added instrumentation in attempts to improve the ability to do more with them. The problem is they are still the same machines. The first five to ten hours of training should teach all the control needed. After that, it's what to do with the machine.

Yes, the more sophisticated instrumentation and power systems allow flying faster and further in conditions that are more complicated; however, the control of the machine remains the same.

I cannot find a book that correctly explains all the basics of aircraft control. I need to write it down...How to Fly an Airplane!

For all Pilots, I have placed additional general information and papers that I have written on my website at...<http://safe-flight.net/>.

You can't change the why's, the engineers figured out and built the machine to do its thing. You must understand what the controls do and just go fly the machine.

Is this enough? How does one tell the aviation training industry to question what is currently going on?

Before solving or changing anything, they need to first define the problem...control!

Any significant change can only come from acceptance of supervising authorities.

INTRODUCTION

Let's Review Real Life

Pilots make different kinds of emergency landings. The accident reports often describe the incident having ended with the aircraft either stalling and crashing or landing with excess energy.

An emergency touchdown resulting from the aircraft stalling is not a landing but a crash. A stall leads to the aircraft falling. It is not flying during the period of stall. Gravity is a huge acceleration factor even when falling a few feet. The most common attitude of an inadvertent stall is landing or crashing on one wing first.

Landing with excess energy means the approach indicated-airspeed was too fast to allow a normal touchdown. Almost three-fourths of emergency off-field landings have approached with excess energy, and then float to or beyond one-half the length of the chosen landing area.

What is going on that these same kinds of incidents continue to happen week after week, year after year in spite of all the concern?

1. Initial training is a significant part. Most pilot training does not include complete use of aircraft controls for directing flight. Few pilots are prepared to identify and fly a gliding approach for touchdown at a specific area.
2. Though private pilots are the ones flying most of the single-engine aircraft there is no licensing requirement for private pilots in the U.S. to demonstrate proficiency in idle-power spot landings. This is the approach required to make engine-out off-field landings. The emergency landing training currently demonstrated is an idle-power approach to a chosen field with a go-around five hundred feet above the ground. This does not teach final approach to touchdown procedures.
3. Glide control proficiency is not required for extending glide distance in ground-effect.
4. There is seldom teaching of visual "Directed-Course" approach technique (flying collision courses to a point), to enable judgment of touchdown for all landings.
5. The accident doesn't occur until touchdown! There has never been any suggestion of how to survive touchdown to stop, and that is the most exciting part.
6. Non-instrument rated pilots flying into weather, often become visually disorientated allowing the aircraft to enter extreme attitudes so lose control and crash. There is little training of technique for flight with minimum input to the ailerons and elevator for prevention of entering extreme attitude.

Real Life Flight

In this book, the emphasis is on how to control aircraft. From the study of proper control, pilots can better understand the input and response required for their flight. There is little reference to aircraft design theory. The pilot must deal with each aircraft as built.

All aircraft operate in the same manner; the same principles of physics apply to all. The methods of flight control apply to all aircraft and are the answer of basic questions about aircraft control for any level of piloting.

When in flight you aren't going to think about how they built the thing. You just act and react according to what it takes. The important thing is what does it take? In this book, there is an explanation of what and why. It may help if you know why since it gives you a way to plan and expectation of the different reactions to control inputs.

All professions have their language. Pilots should be familiar with the same terminology of flight. In this book, there is emphasis on use of correct terminology, such as pitch and indicated-air-speed, as well as less common terms such as Direction of Motion, Directed-Course for visual control, sustained thrust, excess thrust, and component-forces. All terminology is in the expanded Glossary–Index.

Consistent and regular use of terms ensures understanding. There are certain terms used interchangeably. For motion, the term indicated-air-speed instead of speed or airspeed, the latter two are measurements of distance over time. The terms indicated-air-speed, pressure-speed, or indicated pressure-speed are used by the pilot for control of flight maneuvering and structural limitations.

In this book, primary reference to flight-control functions and related technique regarding an aircraft is with “tractor” thrust acting forward of the center of mass. From this starting point, we will discuss how to utilize the flight controls, engine and gravity component-thrusts with stabilizer/elevator pitch trim.

The discussions of flight control throughout the book will cover all realms of flight. The design and construction of an aircraft is to fly, the pilot only controls. Though how aircraft fly is the realm of Engineers and Designers, knowing why the aircraft flies helps understanding what is going on and what to expect when controlling.

A perspective to manual control found in Appendix 1, “Physiology of Manual Flight Control” is an important reference to learning the mental aspects of manual flight control input.

- Chapter-1 evolves the principles and terminology of how aircraft fly.
- Chapter-2 introduces pilot input as it relates to the function of the controls in different flight conditions and scenarios.
- Chapter-3 and Chapter-4 discuss visual control for maneuvering, approaches, landings, and go-arounds.
- Chapter-5 and Chapter-6 present takeoff and landings in different conditions.
- Chapter-7 presents air-density, its effect, and limitations on engine performance and related maneuvering control.
- Chapter-8 is about stalls, the cause, avoidance, and recovery from stalls.
- Chapter-9 presents various aspects of emergency landings, from an initial incident through maneuvering to a landing site, the landing, and survival of the landing; it is about controlling the machine when power is lost.
- Chapter-10 is a review of flight control illustrating a short flight through the different scenarios and recommendation as the initial flight for every Student; start of taxi, takeoff, climb, maneuvering, descent, and landing.
- Appendix 1 is about the “Physiology of Manual Flight Control”. This is an explanation of the human factors causing over controlling when flying manually and a technique for attaining proper elevator trim for an indicated-airspeed.
- Appendix 2 reviews basic “Reciprocating Engine Operation”.
- The combined Glossary–Index is important for the reader to consult for understanding terminology if questioning the use of any term. There may be a few differences in the use of some common terminology.



Chapter 1-----PRINCIPLES OF FLIGHT

This chapter discusses how aircraft fly. The design of an airplane is to fly; if started and turned loose they can fly by themselves. Pilots can't control the design but should understand what causes the aircraft to fly.

There is mention of some basic terms of math and physics. If you aren't conversant in this, don't worry about it. It mostly justifies the arrows pointing to show direction of the different pressure forces causing lift, load, thrust, motion, and drag.

Flight

There are high-powered machines that can fly vertically with only engine generated motion through thrust lifting, however most airplanes use much less power by utilizing forward motion to create aerodynamic lifting forces from reaction to displacement of the mass-of-the-air. This enables flight that is more economical.

Any change of attitude or altitude will require an increase or decrease of thrust. Sustaining any maneuver in level or climbing flight will always require increased engine thrust to cause the climb, turn, or increased indicated-airspeed, and in descending flight, gravity component-thrust does the same while sustaining the flight.

Engine mounting can be forward of the center of pressure causing its thrust to pull the aircraft, as a "tractor" engine; or it can be a mounting aft resulting in a "pusher" engine with its thrust acting from behind this center. There are some important differences in required control depending upon where the thrust acts on the machine.

Flight Forces

Aircraft fly and are controlled with application of forces and change of forces. Flight training typically discusses the balance of forces acting in steady state flight as weight versus lift and thrust versus drag. This is a simplification of all the forces involved and considered by many as sufficient for demonstration or understanding.

The reality is; if not distinguishing all the forces involved, it does not allow complete understanding of airplane control.

In constant indicated-airspeed flight, the balance of forces include all the vertical component-forces of aerodynamic and engine thrust component-lift equal to and opposite the mass-weight of gravity plus added loading such as the aerodynamic loading from stabilizer and elevator, and any acceleration "g" forces of maneuvering.

The fore/aft balance for constant indicated-airspeed flight is the component of thrust in the direction of motion, opposite and equal to

the retarding pressure of mass displacement and friction forces from the airflow plus rearward component-vectors from aerodynamic lifting and gravity, all acting together as drag.

Aircraft Lift and Load in Wings Level Climbing Flight

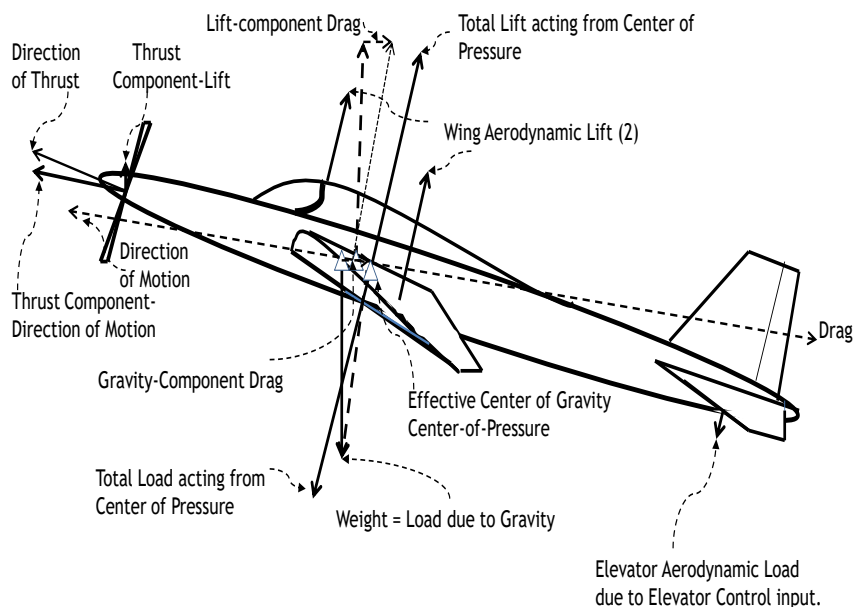

Fig. 1-1

The inflight balance of vertical forces are the vertical components of lift from the wings, body, and engine thrust component-lift away from the top of the machine and the opposing the gravity force directed to the earth from the aircraft mass plus any aerodynamic component “g” force and stabilizer aerodynamic loading directed away from the bottom of the machine.

These different forces are the total of the component forces acting out the top, bottom, front, and rear of the aircraft...as related to a current direction of motion (attitude). Note that most flight is close to horizontal so it makes it seem these forces may be relative to the ground. However, they are not relative to the ground but to the current aircraft orientation. Only gravity is always toward the surface.

Vectors

The numerous forces involved in flight makes it difficult to generalize them if wanting to understand how they affect flight control. In the operation of a flight, a pilot never needs to know the actual value of any specific force, but should always understand how control input affects the forces acting on the aircraft.

The reactive forces involved in flight result from encounter and displacement of the airmass (mass-of-the-air) relative the aircraft velocity of motion. The acceleration of airmass (mass-of-the-air) by the engine and propeller is causing thrust. The reaction to motion when passing through an air mass is causing the aerodynamic lift. For simplicity in this text, we will call mass-of-the-air, "airmass". The term "an air mass" will refer to the portion of the atmosphere in which the aircraft is operating.

Note there are "five" different directional forces. These are thrust, drag, lift, load, and weight (gravity) forces. Knowing how all these different forces act on the aircraft requires consideration of vectors and the direction of related component-vectors.

Engine thrust is parallel to the dimensional longitudinal axis. The reactive force components at the engine attachment are one forward sustaining the direction of motion, and one outward as lift.

Wing aerodynamic lift is considered acting from an area approximately one-quarter back from the leading edge of each wing and the body aerodynamic lift through some point out of the top of the fuselage.

The stabilizer/elevator aerodynamic load is away from the bottom at its attachment and the maneuvering "g" loading is away at a center of pressure. Gravity acts from the center-of-mass, always directed toward the earth.

Force Vectors

The following description of forces is a basic review of how Vector-components relate to those forces.

A vector is force in a direction. Forces act from different areas on an aircraft and their reactions are a combination as if each were two smaller component-forces acting 90 degrees from the other at that point. Seldom are there forces reacting in the exact direction applied, so almost always will have these directional component-forces.

In aviation, it is usual to discuss different forces by a name. Thrust forces pull or push to cause forward motion of the aircraft as the mass reaction to blasting air pushing at its attachment and, in descent, gravity component-thrust pulling from the aircraft center-of-mass.

Drag forces acting opposite the direction of motion are the airmass pressures resisting displacement, the frictions from flow around the

surfaces, and small rearward components of both gravity and aerodynamic lift.

The direction of the aerodynamic and engine thrust component-lift forces are out the top of the aircraft while aerodynamic loading forces act out the bottom of the aircraft. The aircraft weight by gravity acts against the vertical components of aerodynamic lift and engine thrust component-lift, directed away from the center-of-mass toward the earth, no matter the attitude of the machine.

All these forces are acting in different directions though not necessarily exactly opposite each other. When changing attitude, direction of lift forces relative the earth change so the vertical component-vectors of lift that sustain the flight change.

When maneuvering at constant indicated-airspeed flight, aerodynamic lifting is constant because the aircraft angle of airstream encounter does not change. It then requires coordination of thrust for its related thrust component-lift to maintain the vertical lift components supporting the aircraft weight. If engine component-lift is not sufficient to maintain constant vertical component-lift, the aircraft will descend using gravity component-thrust to maintain the constant indicated-airspeed.

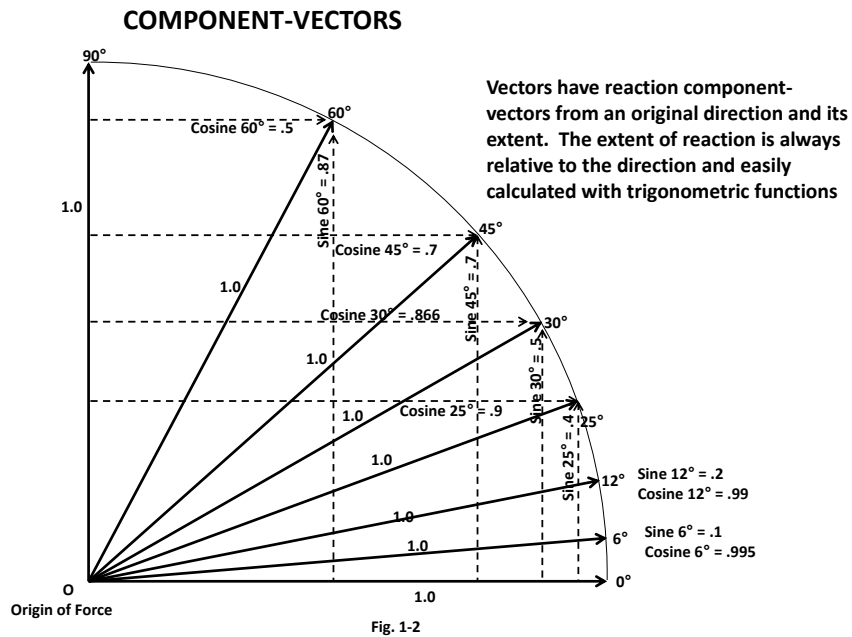

VECTORS AND VECTOR COMPONENTS

Level Flight Engine Lifting

Right Triangles have specific constant relationships of the vector direction, its extent, and that of the related component legs.

The component vectors are always ninety-degrees from each other. The two included angles always add to ninety degrees.

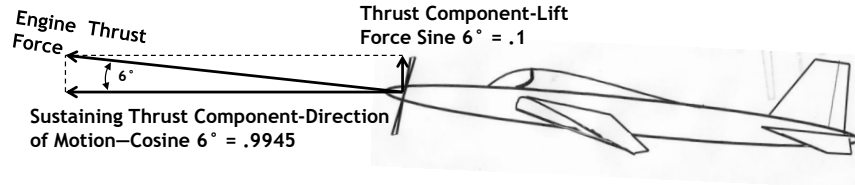

Level flight horizontal motion with six-degree nose up angle of the aircraft attitude (ANGLE-OF-ATTACK) encountering the airmass.

Two hundred pounds of engine thrust will have 199 pounds ($200 \times .9945$) of horizontal thrust into the free stream air and 20 pounds of lift at the nose ($200 \times .1$). A resulting V_y (65 kts.) indicated-airspeed causes approximately one-pound forward resistance per square inch of frontal area.

Fig. 1-3

Component-Forces

There are related component forces of an applied force at any time the reaction to that force is not exactly the opposite direction of that applied force.

The understanding of these forces and the related component forces helps understanding flight control and control inputs required, however this is only good for understanding the cause of flight, as a pilot in flight, you merely control, visually directing the aircraft toward a distant point.

Maneuvering is a change from the equilibrium of constant altitude, constant indicated-airspeed, with constant thrust. This means change of attitude of the aircraft is steering by input of control causing related directional changes of the forces.

The quantities of these component forces relate trigonometrically. If knowing an angle of encounter or reaction and a force, it is possible to calculate the reacting force and its direction. This is not something a pilot does, but the study allows understanding of what to expect when inputting control forces.

With a body attitude angled above the direction of motion, the engine thrust has a large sustaining thrust component in the direction-of-motion and a small lifting component-force 90 degrees away from that direction of motion, all acting at the engine attachment.

V-Speeds

There are different operational indicated-airspeeds designated as V-speeds. V_y is an optimum rate of climb indicated-airspeed for time and distance and V_x is an indicated-airspeed optimum climb angle for attaining maximum altitude at the aircraft current weight and configuration. V_y and V_x flight is often slower than most in-flight operations but used here for demonstration purpose.

Reference will be made to a speed V_{me} (maximum endurance), an indicated-airspeed that gives most time in the air without regard to range. This then is the most efficient indicated-airspeed for current conditions.

In addition to V_x and V_y , there are other operational pressure speeds. Best-glide (V_{bg} or V_{mr}) indicated airspeed attains maximum range, being the most efficient engine out pressure speed for an aircraft and used for engine out operation.

For the wing, when generating lift, a typical condition might be V_y indicated-airspeed flight that will be a wing and body air-encountering angle of 6-8 degrees above the direction of motion.

The sine of 6-degrees is .1, and the cosine is .99. This means .1 (one-tenth) of this total thrust is considered acting in a direction ninety degrees from the other .99 of that total force.

The pressure from encountering air mass at 60-65 knots is approximately one pound per square inch. At V_y , the airflow encountering the angled aircraft travel is being deflected under the wing with an upward reaction (.1 times 1 lb./sq. in. = .1 lb./sq. in.) and is the aerodynamic component-lift force of the air mass displacement at that velocity under the wing.

The airflow in the direction of motion, deflects slightly away as it passes around the wing, slowing slightly (.99 x 65 kts. = 64.5 knots/hr.), and there is a small deflection of 6.5 knots/hr. away (.1 x 65 = 6.5 knots).

What happens in the eyes of pilots; they can't see any of it. It is just airflow always deflecting slightly away as the wing passes through. The displacement away causes a small reaction force under and over the wing creating lift.

The air mass passing over the top of the curved wing surface travels along the upper surface with a small downward changed direction and increased velocity resulting from the reduced pressure across the top surface as part of the reactive displacement lifting from below.

The wings of this small aircraft will have approximately 16,000 sq. in. of bottom surface, so the lift component (16,000 sq. in. x .1 x 1 lb./sq. in. = 1600) will be 1600 lbs, the weight of the airplane. This is a

simplification of the lifting but it's kind of how it happens. You can see it always requires motion (mass encountering pressure), called induced-air speed pressure, to make this all happen. The pilot controls that motion of the aircraft.

Aerodynamic Lift—Newton and Bernoulli/Coanda

The explanation of aerodynamic lift generation is nice to know. The engineers have designed the wing, the pilot just flies. Most of the natural laws of physics defining the cause of lift were first defined by these different scientists:

Newton (1642-1727):

There is a force around the wing causing lift as a reaction to the displacing mass-of-the-air. A simplified statement of Newton's Laws of Motion;

1. A body at rest will remain at rest and a body in motion will remain at the same speed and direction unless acted on by an outside force.
2. Acceleration occurs when an outside force acts upon a moveable object.
3. For any applied force there is an equal and opposite resisting force.

Bernoulli (1700-1782):

There is associated lift allowed by that portion of air passing over the top curved surface of the wing. The deflected mass over the top must flow further in its attempt to replace that deflected over the wing. The increased velocity as this mass passes over the wing simultaneously results in reduced pressure allowing the resulting lift.

This is the Bernoulli Effect, and is the relationship between the changed velocity of air mass flow and its related pressure. When the speed of the flow over the wing increases, the pressure simultaneously decreases. The reduced pressure in this mass flow of the air allows the resultant aerodynamic lifting force under the wing.

Coanda (1886-1972):

Coanda Effect is the tendency of the mass of liquid and gas flow to attach itself to a surface and to remain attached even as the surface curves away from the initial direction of encounter. This effect changes the direction of that mass flow.

Air mass flow, when deflected over the upper curved wing surface, will attempt maintaining that flow along the curved surface due to the Coanda effect, resulting in a changed flow direction. The partial voiding behind the upper wing surface allows the acceleration of the air with its changed direction as it attempts to replace that voiding.

Aerodynamic Lift

The generation of aerodynamic forces comes from the motion of a structure passing through the mass-of-the-air. An aircraft design is such a structure. The angular attitude of the aircraft above the direction of travel forms a frontal area of the machine that meets and diverts the air.

The formed wings and body of the aircraft at an angle of encounter divert the airflow of motion under and over their large surfaces. This angled encounter produces a reaction of an equivalent mass weight of air as downwash around the structure equal to the mass weight of the aircraft resulting in reactive lift forces out the top.

The arrangement of the aircraft meeting the oncoming air at a small upward angle, called “angle-of-attack”, creates a frontal-plate area meeting and dividing the displacing volume under and over the body and wings. For an increased angle of travel in slowed flight, there becomes increased volume under the wing, which slows slightly and travels further in its diversion away from the wing while passing under the structure (Newtonian Effect).

Vy Optimum Air Mass Encounter and Displacement Volume

Wing encounter of free stream air at Vy, six-eight degree wing angle of attack.
Encounter pressure at 60-65 knots is one pound per square inch.

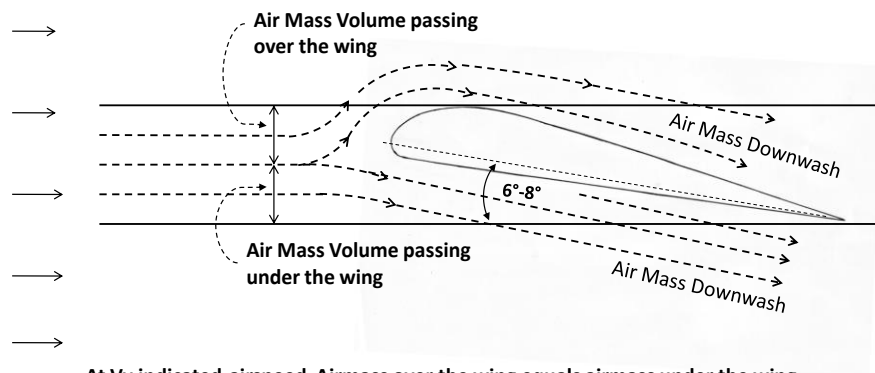

At Vy indicated-airspeed, Airmass over the wing equals airmass under the wing.
Bernoulli/Coanda Lifting over the wing approximately
equals Newton Lifting under the wing.

Airflow over the wing travels further and with increased velocity into partial vacuum.
Airflow under the wing is slowed slightly by encountering previous downward displaced air.

Fig. 1-4

The displaced volume of air over the top of the wing flows along the curved path (Coanda Effect) of the upper wing surface with an increased velocity (Bernoulli Effect) into the voided back of the wing

accelerating the displaced air mass into a downward motion. We call this movement of air mass, downwash of the air.

There is always this reduced reactive pressure (partial vacuum) outward from the partial voiding of airflow over the top of the wings flowing back down toward the back of the wing surface.

The mechanics of this splitting of mass under and over the wing, the dynamic diversion of mass, creates unbalanced pressures between the top and bottom of the wing with resulting reactive pressure outward from the top of the wing form. This is aerodynamic lift.

A small aircraft will require an approximate ratio of only one pound of thrust to sustain ten to twelve pounds (1:10-12) of aircraft mass. A typical small 1600-pound aircraft sustains optimum flight with approximately 160 pounds of air mass as thrust.

The primary aerodynamic lift comes from the wings, and depending on the shape and attitude, there is also some lift generated in the same manner from the fuselage.

The depictions of airflow are relative to rapid motion. That is, the aircraft is moving rapidly away as displacement takes place so, though a displaced particle of air merely moves upward or downward relative the wing, the flow relative to the pilot would appear that the air is moving away.

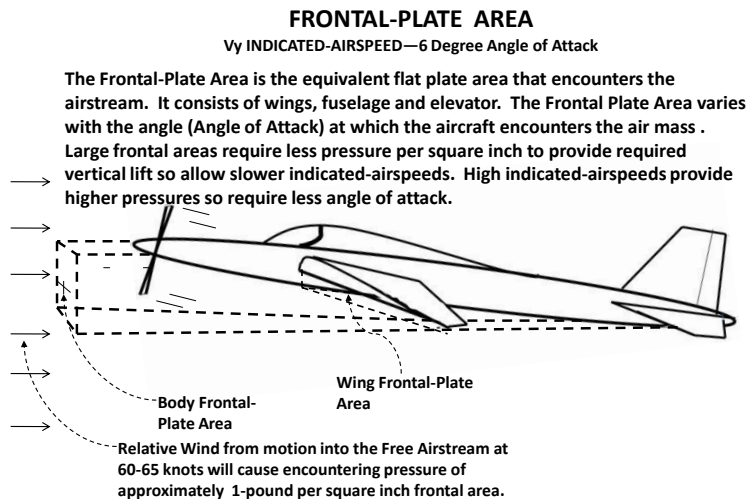
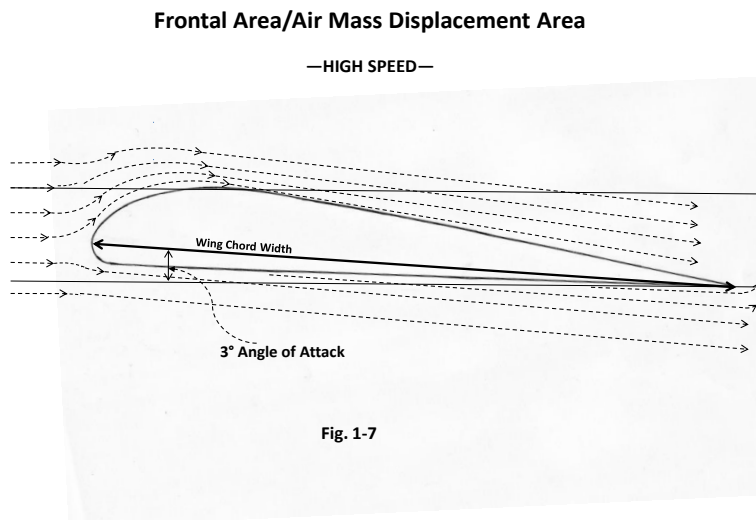
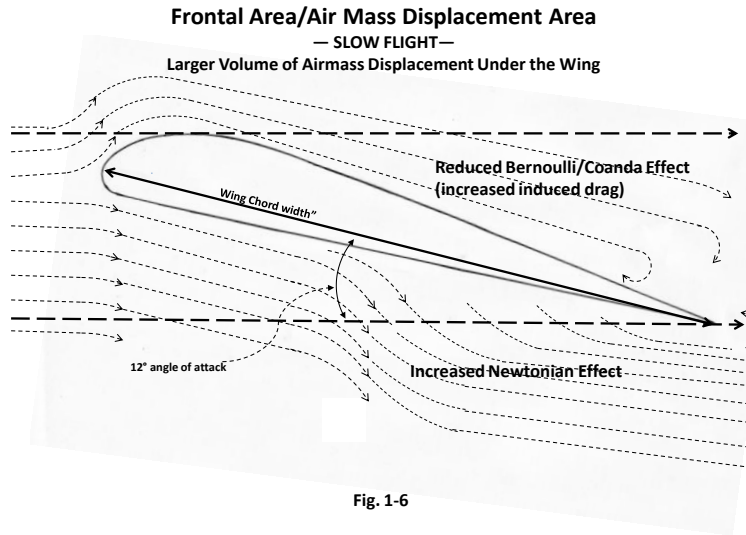

Fig. 1-5

Motion through the atmosphere aerodynamically creating lift in this manner is the usual method to cause flight. This requires significantly less power for causing the required lift and is thus more efficient for flight within the atmosphere.

The development of aerodynamic lift requires that the aircraft wing must always divert air mass under the wing and accelerate air mass over the top of the wing.

The result is at high indicated-airspeeds, there is increased rate of mass encounter from displaced air over the wing with primary lift from the Bernoulli Effect of accelerated mass flow. At slower indicated-airspeeds, it requires increased wing and body angle to increase the mass of airstream encounter, there becomes a greater proportion of mass flow under the surfaces. The resulting increased volume of displacing air is greater than the volume of the machine itself.



The amount of aerodynamic lift force relates to the velocity of airflow, the mass of displaced air, and the distance the displaced air must move around the surfaces. The pitched angle of the wing and body attitude into the direction of motion creates the size of the frontal area that meets and displaces this air.

Frontal areas from changed angles of encounter cause change of the volume of air displacement so require different velocities to maintain sufficient air mass displacement to cause a constant aerodynamic lift force of the aircraft load. The greater the frontal angle of travel, the greater the mass displacement, the less the encountering pressure per square inch required.

Coordination of the aircraft's frontal area (angle-of-attack) meeting and displacing the air mass, determines the indicated-air speed and attitude flown.

This means the slower you want to go, the greater the angle-of-attack, so the nose attitude angle will be pitched higher relative the direction of motion, and the faster you go, the nose will be pitched at a lower angle. At the same time, for any given indicated-air speed, there must always be coordinated engine power/thrust to sustain the flight, no matter where you are going in climb, level, or turn.

A pilot can do nothing about the design or the physics; it is just how things work. Elevator input changes the attitude pitch setting for a different angle-of-attack, *allowing* change of indicated-air speed. Coordinated engine thrust component-forward or gravity component-thrust *causes* the resulting indicated-air speed.

Angle-of-Attack

Angle-of-attack is the aircraft body angle of the dimensional longitudinal axis pitched above the direction of motion. The elevator-pitch control sets the angle-of-attack of the aircraft to the encountering air (relative-wind of motion). Reference is often in regard to wing angle-of-attack, but it is the total airplane, fuselage, wings, and tail encountering the airflow.

It is common to have the wing attachment to the fuselage at a slight angle above the longitudinal axis as an "angle of incidence" allowing the fuselage to travel level in cruise with the wings at a slight angle-of-attack. The pilot has no need to consider this fixed wing attachment, as there is no way to measure an angle of incidence or its effect.

By definition, wing angle-of-attack is the frontal profile angle of airflow encounter between the wing chord and direction of motion. If the wing has no attachment angle, its wing chord being parallel with the dimensional longitudinal axis, the wing angle-of-attack will also be the body angle-of-attack.

All wing forms have a maximum angle-of-attack at which the Coanda effect changing airflow direction over the top surface will be able to conform the flow near the upper wing surface.

Exceeding the angle at which airflow can conform to the upper wing surface (laminar flow) resulting in loss of lift is a stalled condition. This is “wing critical angle-of-attack”. Aft elevator-pitch input causing an attitude exceeding the wing critical angle-of-attack in a positive stable aircraft is by the pilot manually pulling the elevator...the pilot increasing and holding pitch is always the cause of stall.

A specific wing design has a specific critical angle-of-attack. This does not change with aircraft loading. The heavier an aircraft the greater the angle-of-attack required for lifting its load. Heavily loaded (mass and g's) aircraft then always operate closer to the critical angle-of-attack.

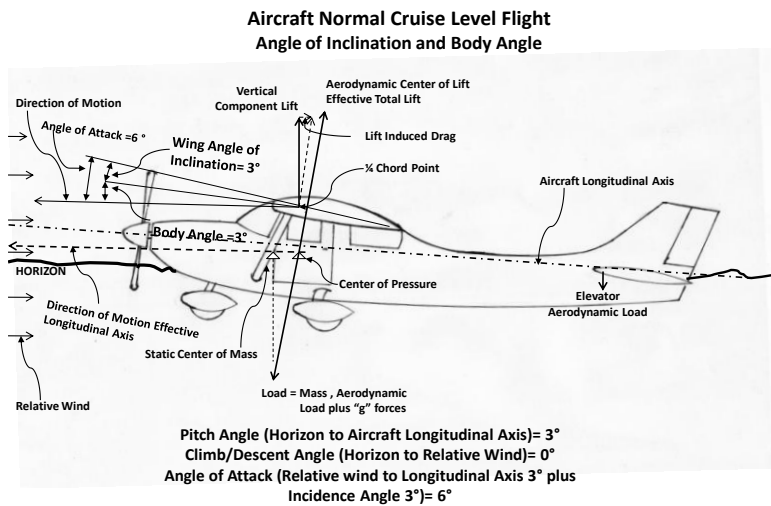

Fig. 1-8

Setting an aircraft angle-of-attack is by coordination of elevator-pitched aerodynamic loading at the tail balancing the aircraft longitudinal attitude.

Engine thrust component-lift, acting from its attachment along the fuselage or on the wings at some moment arm, can also affect the setting of angle-of-attack so is incorporated as part of the coordination of elevator input. Changed thrust and its related changed propeller-blast can affect the aerodynamic load across the elevator of some aircraft also causing angle-of-attack change.

Aircraft Balance

All forces have moments acting through their moment arms to the current center of pressure point of rotation. Flight control is adjusting these forces for the balance to cause desired motion.

Our example aircraft at its optimum V_y indicated-air-speed and 160 pounds of thrust will be in motion at an air-encountering angle of at least 6 degrees angle-of-attack, so will have a continuous 16 or more pounds of thrust component-lift at the engine ($\sin 6^\circ = .1$) contributing to the total lifting forces.

This engine-lift acts along the fuselage as its moment arm to the center of pressure. Coordinated with the elevator aerodynamic loading, this total lift or load maintains the balance at an angle-of-attack for a specific indicated-air-speed.

The difference with in-flight balance in an aircraft is that all forces act at fixed positions. The engine lifting is at the attachment of the engine, and the elevator and horizontal stabilizer aerodynamic lift or load acting at their structural placement on the empennage. The center of mass acts at its current location forward of the center of lift.

Change of any one balancing force in these locations causes a change of the fulcrum position near the aerodynamic center of lift, moving it slightly forward or aft and becoming a new center of pressure. Acting at their attachment, elevator aerodynamic load combined with engine thrust component-lift set the balance for a specific indicated-air-speed angle-of-attack.

The basis of static loading is the designed aerodynamic load/lift limits of the stabilizer and elevator control. Loading is critical and not maintaining the loading limits could lead to loss of aircraft control. Manufacturer published tables and charts enable loading an aircraft within its balance limits.

Moment, Moment Arms, and Torque

A body in flight is free to rotate and will always turn about its current center of pressure. A moment is the arm of a force from a distance that tends to rotate the system. That distance (length) is the moment arm of the lever acting from the related force.

Aircraft control is by pilot input to the flight and engine controls. Input to the elevator, engine, or rudders cause small directional forces acting on the fuselage over their moment arms.

In an aircraft, the inputs of control for balancing forces are always at the same points so this requires the fulcrum to change with any change of force. The changed fulcrum becomes the "center of pressure" of all forces.

Moments, Moment Arms, and Torque

A force acting on a lever causing torque (rotational tendency) creates a "moment over the moment arm".

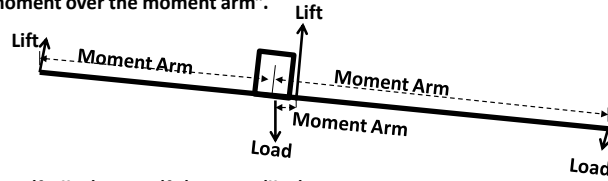

$$\text{Moment (ft. lbs.)} = \text{Arm (ft.)} \times \text{Force (lbs.)}$$

A moment is the tendency to produce rotation (torque) about a fulcrum. The dimensions of a moment is distance along the arm from the force to the fulcrum times the force. (i.e. foot-pounds)

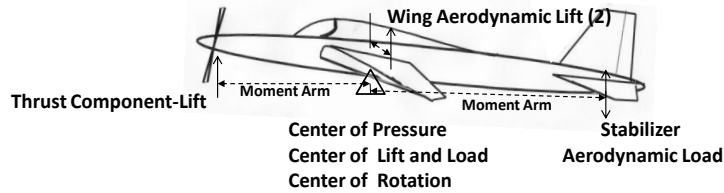
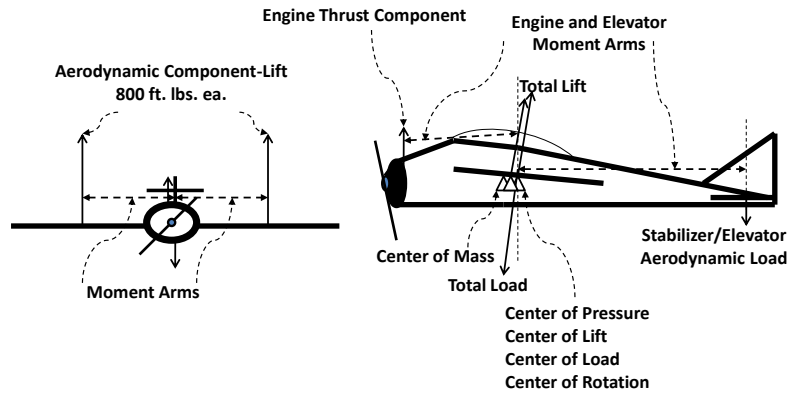

Fig. 1-9

Engine and Aerodynamic Lift Forces and Their Moment Arms



At V_y indicated-airspeed, 1600 lb. Aircraft with 160 lbs. thrust at 6-Degree Wing Angle of Attack Wing Moment Arms 8 ft. each, Engine Moment Arm 10 ft., Elevator Moment Arm 20 ft.

Fig. 1-10

Center of Pressure—Point of Balance

There is a significant difference in the forces on an aircraft between sitting on the ground and being airborne.

The center of pressure is the airborne equivalent of a center of gravity. The aircraft reacts to the sums of all forces acting on it. On the surface, there are no forces other than the mass weight as load and force through the wheels as lift.

When airborne, different lift and load forces are involved, therefore an equivalent center of gravity is actually a “center of pressure” located at the neutral point of all applied forces. This becomes the center of rotation for maneuvering, moving slightly with any change of a force.

The notion that all things be correct makes it necessary to come up with some way of having standardized terminology. I first thought “effective center of gravity” was one way to describe the center of rotation. In retrospect that does not really change the idea that center of gravity, the mass load is something on the airplane when in flight. Perhaps “center of load” is more appropriate to relate it as a force out the bottom of the machine and opposite “center of lift”; then again, it all occurs at the “center of pressure”, also the “center of rotation”.

Balance

“Aircraft Static Balancing” of Mass and its Gravity Force

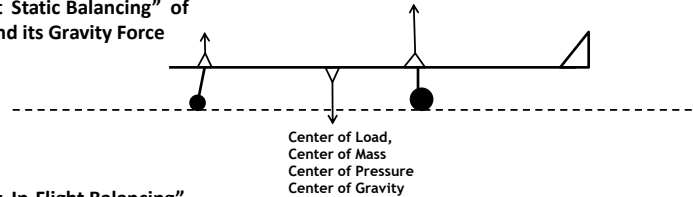

“Aircraft In-Flight Balancing” around total of all Forces

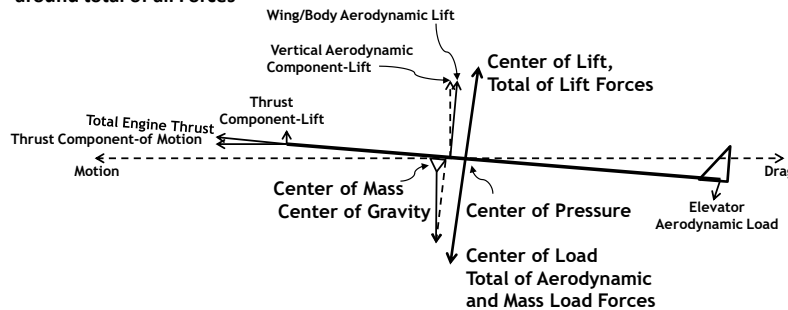

Fig 1-11

Gravity effect on the mass is one of the many forces acting on the system. The momentum of the machine per Newton, relates to the mass involved.

Center of Gravity is always a significant factor when preparing for and conducting flight as it relates to the design control forces for balance. In flight, the gravity force is just one of the load forces involved. Note that as mass changes in flight so too the center of mass changes. Again, it is one of the load forces so affects the center of pressure as any other load change.

Though there is a significant difference in the forces on an aircraft between sitting on the ground and being airborne, this is of minimum significance to a Pilot controlling an aircraft, but since the beginning of flight, it has been the fashion to use center of gravity as a generic term relating to maneuvering. When relating to gravitational effect, it is only one force acting at the center of mass and always toward the surface.

Gravity effect on the mass is one of the many forces acting on the system. When considering energy factors, the momentum of the machine relates to the mass involved.

Energy and Energy Sources

Energy is the ability of a source to cause work (force times distance) and comes from position, heat, or chemistry as potential energy, and from motion of mass as kinetic energy.

You cannot create or destroy energy, but only convert it from one form to another. Potential energy transforms to kinetic energy and kinetic energy transforms to potential energy. In usual conditions, there are significant energy losses as friction and heat from inefficiencies in operation.

Aircraft kinetic energy in flight becomes potential energy of altitude (climbing or zooming up), and again becomes kinetic energy through descent acceleration (diving). This is a simplification of the mechanics of energy used for discussion of flight performance.

These manifestations of energy, motion and position, allow understanding the response when maneuvering an aircraft. For flight, reference is to an arbitrary aircraft attitude controlled above the surface.

Gravity is the natural attraction of earth's huge mass to the aircraft's mass so is a force always directed toward the surface of the earth. Kinetic energy is mass in motion, as the reaction from the thrust forces. The momentum of your airplane's mass is its kinetic energy.

Engines develop thrust force by burning fuel to extract the potential energy. The resulting energy of burning fuel is expansion of gases pushing a piston, turning a crankshaft and propeller to accelerate the mass-of-the-air. The acceleration of mass-of-the-air (blasting air) causes a reactive thrust force creating aircraft motion, kinetic energy. This all occurs with large heat energy losses that dissipate into the air.

Similarly, the jet engine develops thrust force by burning fuel. The resulting energy is expansion of gases turning a turbine and compressor, accelerating the mass-of-the-air. Thrust is the reaction to accelerating this mass-of-air toward the rear (blasting air).

Engine thrust is a force directed to push (pusher) or pull (tractor) transforming into kinetic energy of the machine's motion. All aircraft have engines for developing the power to generate thrust directed to cause motion (kinetic energy).

Your aircraft at altitude is a source of potential energy. The aircraft weight as affected by gravity and directed by the flight controls produces gravity component-thrust from descent or gravity component-drag in climb.

Velocity of the aircraft mass is its kinetic energy. The resistance of air mass displacement and friction of flow to aircraft momentum is a decelerating thrust-effect, which causes slowing as drag force.

Flight control is energy management directing the conversion of the energy from one state to the other. Think rollercoaster, zooming up and coasting down. Pilots use this energy exchanging in many ways for maneuvering. There is an equivalent available thrust by gravity (almost four times maximum engine thrust) from the aircraft mass for going down (burning altitude). That is a lot of available thrust.

Thrust

Engine power provides the primary motivational thrust for sustaining flight. Engine generated thrust is always in the forward direction the aircraft is facing and acting from its attachment. However, anytime the aircraft is at an attitude away from the direction of motion there will always be a small thrust component-lift acting at the point of engine attachment.

Gravity acting from the center-of-mass is causing the weight of the aircraft. However, for assuring positive stability, the aircraft mass loading is forward of the aerodynamic center of lift, so depending on aircraft attitude, there becomes a small gravity component-thrust or component-drag affecting the aircraft.

Descent angles below level flight directs this as gravity component-thrust while attitude angles above level (cruise and climb), directs this aft as gravity component-drag. In steep angled descent, the gravity component-thrust can quickly become extreme.

Gravity Component-Thrust for Sustaining Lift

A 1600-pound aircraft in engine-failure optimum V_y glide, to prevent falling, requires the continued 160 pounds of thrust to sustain the indicated-air speed for generation of its aerodynamic lift. In engine-out

descent, there becomes a forward gravity component-thrust from the aircraft's 1600 pounds of vertical gravity force.

Controlling to a six-degree descending glide angle ($\sin 6^\circ = .1$, 1600 lbs. $\times .1 = 160$ lbs.) will sustain the aircraft lift for the V_y 65-70 knot (Best Glide) indicated-airspeed.

Engine Thrust Component-Lift

Anytime the direction of thrust alignment from the engine is not in the direction of motion because of mounting location and/or a pitched angle above motion, there becomes a component-vector of that thrust outward at the engine attachment as lift.

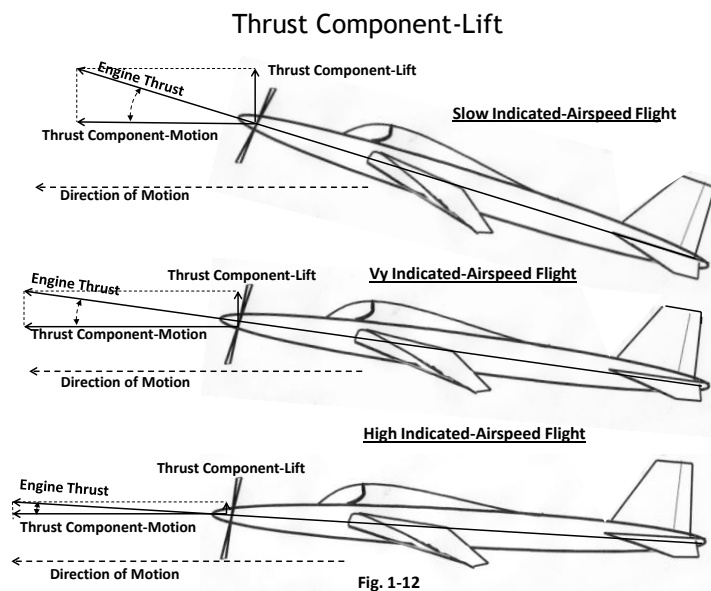

Engine Performance

Reciprocating engine ratings do not measure the thrust available so seldom is actual thrust considered in teaching or learning small aircraft control. The various kinds of propellers and their efficiencies when developing thrust make it difficult to determine the actual thrust an engine can produce.

The usual consideration of reciprocating engine performance is a generalization that power must increase or decrease to get desired performance. Obtaining expected performance is available only with use of tables in the Pilot Operating Handbook (POH) or, recommended, actual flight-testing of your specific aircraft.

Engine power available decreases with increased altitude, temperature, and humidity due to reduced density of the air, so

available thrust will reduce with an increase of these factors. Pilots must carefully consider the performance possible. There is always limited thrust available when operating at high-altitude airports for takeoffs, landings, and airborne maneuvering.

Jet engines do not have propellers involved, so thrust is the measure of their performance. The jet engines compress air for burning so allow much greater altitude performance. Still the mass of the air affects their performance in a similar manner as the reciprocating engines.

Thrust Available

As a pilot, you must always be aware there is considerable reduced power and related thrust when operating in the higher altitude low air-density conditions. That is why an aircraft has a maximum altitude it can reach. There will always be much reduced power available for maneuvering at the higher altitudes of low-density air.

For this book, some generalized numbers for thrust available demonstrate the effect of thrust for operation at higher altitudes. This example and related numbers do not necessarily reflect a particular aircraft.

The actual thrust required for any aircraft varies considerably depending on the designed aerodynamic form. A small aircraft sustains flight at approximately one pound of engine thrust for each 10-12 pounds of weight (1:10 to 1:12 ratio). A 1600-pound aircraft will then require approximately 160 pounds of engine thrust to sustain itself at its optimum V_y level indicated-airspeed.

The design rating of each engine and propeller limits the available thrust. A typical manufacturer rating for a small aircraft engine will range from 100-200 horsepower attained when operating at sea level standard atmospheric conditions.

For this example problem, assume a 110 horsepower engine on a 1600-pound aircraft, and expect 460 pounds of thrust at full manufacturer rated power with this particular fixed-pitch propeller-generated thrust at the sea level standard conditions.

The optimum indicated-airspeed (V_y) for this flight is 65 knots. The 1:10 thrust to weight ratio to sustain this aircraft in flight at this indicated-airspeed will then require 160 pounds of thrust. At the sea level liftoff, there will be 300 pounds of excess thrust (460 lbs. - 160 lbs. = 300 lbs.) above the 160 pounds required to sustain the flight at that airspeed. This allows sufficient excess thrust for positive low altitude climb rate and maneuvering capability.

Engines must burn a certain amount of fuel to attain their maximum rated thrust. The engine fuel/air induction piping is a fixed size so the maximum volume of air intake is constant at full open throttle.

As altitude increases, the air becomes less dense so the oxygen mass content per unit volume of air decreases, the amount of fuel the engine can burn then also decreases, causing the power available to decrease.

Maintaining a proper fuel/air mixture requires gradual pilot control of the mixture control, reducing the fuel (leaning the mixture) to maintain a proper ratio of fuel and oxygen that will allow efficient burning. The effect is as if gradually closing the throttle.

Every engine has this limitation. The availability of oxygen to burn fuel limits the performance of all engines.

When flying this little airplane, it will only go up to 15,000 feet. Now at 15,000 feet, there is only the 160 pounds of thrust from the engine sustaining the aircraft at its optimum indicated-airspeed of 65 knots.

What has happened? The lower half of the atmospheric mass occurs under eighteen-thousand feet so the reduction of pressure density is approximately linear. That means there is gradual reduced elemental oxygen in each volume of air available for burning in the engine. This occurs continually throughout the climb.

There has been a loss of twenty pounds of possible thrust for each thousand feet climbed. At 5,000 feet, there was 200 pounds excess thrust available for climb or maneuvering, at 10,000 feet, 100 pounds of excess thrust for climb or maneuvering, and finally at the 15,000-foot level there is no excess. Only the 160 pounds of sustaining thrust remains, and there is no excess for climb or maneuvering.

Thrust Required

In the previous section, we determined it took 160 pounds of sustaining thrust to maintain our example aircraft in level, constant V_y indicated-airspeed flight. This is the thrust required to maintain this aircraft in this condition of sufficient air mass encountering pressure to generate the constant lift supporting itself in the air.

Any maneuvering away from this condition with climb or level turn changes the direction of all the lift forces so requires added thrust to sustain the vertical-component forces needed to maintain the constant lift opposing gravity effect. The reduced excess thrust available in low air density (high-density altitude) conditions limits this maneuvering.

Throughout any maneuver at this constant angle-of-attack, the related indicated-airspeed requires constant sustaining thrust plus some excess thrust to cause and maintain changed attitude. All flight requires sustaining thrust from the engine or gravity component-thrust, and for maneuvering of attitude, it requires some excess thrust be available to cause and sustain change.

Common operation is at indicated-airspeeds substantially greater than the V_y optimum so allows some use of elevator-pitched changed angle-of-attack to maneuver. This is using the momentum of the aircraft, as an energy exchange, using deceleration by induced drag or climb to cause attitude change. Normal initiation of small altitude corrections in flight is in this manner.

Most texts profess using elevator-pitch for added lift to maintain level turns. The limit of this technique is the deceleration allowed before reducing to unsafe operating indicated-airspeeds, so if a turn is prolonged, it still requires added thrust to sustain the flight or result in possible stall.

The range of indicated-airspeeds between V_y angle-of-attack and wing critical angle-of-attack is relatively small. When operating near or below V_y indicated-airspeed, elevator-pitch input in level turns is not a recommended procedure as it allows slowing and can quickly become dangerous.

In addition, if operating at high altitude low-density conditions, you may not have much excess power available so minimum-banked level turns may be all that are possible without descent for use of gravity component-thrust.

Note, using elevator-pitch with increasing angle-of-attack will never allow a constant indicated-airspeed level turn.

Gravity

Gravity is a force vector always directed from the center-of-mass toward the earth, no matter the aircraft attitude. The potential energy of altitude is from gravity, so is available only when airborne.

Continued flight requires that in some manner there be opposite directed constant vertical lift forces to balance the gravitational loading effect. For all flight, there is a specific velocity at a given wing angle-of-attack causing sufficient air mass displacement to cause the required aerodynamic lift.

This information is available in the aircraft POH or by flight test. When airborne, it is not possible to stop, so reducing engine thrust below level flight sustaining thrust, or maneuvering the attitude in any way that reduces the vertical component-lift, there will be descent caused by the gravity force. Gravity will always continue the motion, by sustaining the flight with elevator pitch controlled gravity component-thrust in gradual descent, or if stalled, uncontrolled falling.

Reducing engine thrust lessens its thrust component-lift allowing negative climb (descent) with a nose lowered longitudinal attitude allowing the addition of gravity component-thrust. This is gliding or partial gliding to sustain the aircraft lift.

Attitude change with elevator control is pitch steering by setting an angle-of-attack pitch for attaining gravity component-thrust (gliding or reduced engine thrust partial gliding). While sustaining an indicated-airspeed with elevator pitch, the ailerons and rudder maintain the directional steering of descent.

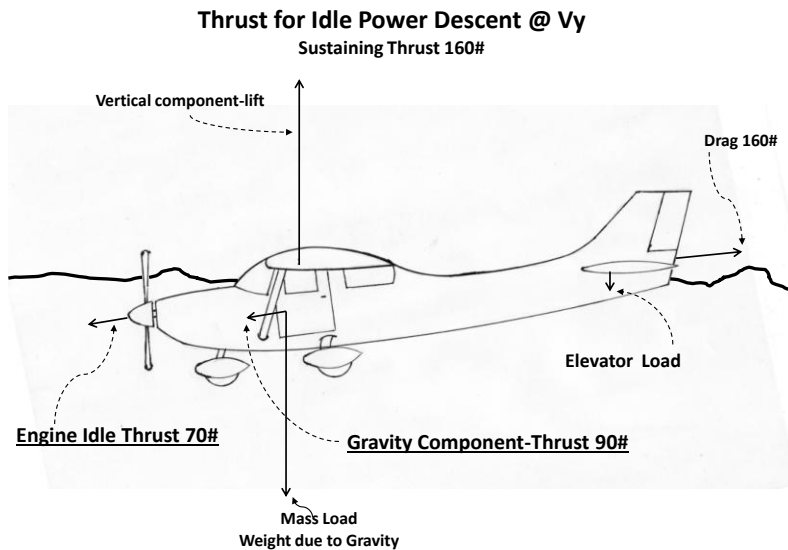

Gravity Component-Thrust

Gravity control is pilot controlling of pitch attitude for the required sustaining gravity component-thrust. This is coordinating the power setting and angle-of-attack for attaining and sustaining the desired descending indicated-airspeed.

Reducing below the sustaining engine thrust or manually maneuvering to any descending attitude will cause addition of gravity component-thrust to maintain the sustaining thrust for any current elevator-pitched indicated-airspeed.

Drag Forces

Drag force results from the pressure and flow friction forces resisting the displacing air mass from the aircraft direction of motion. In addition, the small pitched-up attitude of travel will cause induced drag, a retarding component from both, gravity acting from the center-of-mass and aerodynamic wing and body lift acting from the center of aerodynamic lift.

In sustained constant indicated-airspeed level or climbing flight, the engine delivered thrust component in the direction of motion will equal

drag. When equal, there is no net increase or decrease of indicated-airspeed.

Attitude change redirects aerodynamic lift, so the retarding component forces of drag will change with any maneuvering, thereby requiring coordinated engine or gravity component-thrust change for sustaining any new attitude.

Drag and Component-Drag Forces

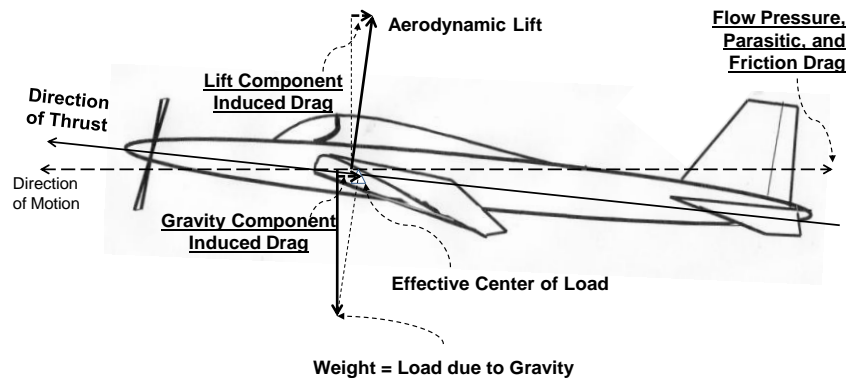

Fig. 1-14

At all times in flight, there will be coordination of sustaining and excess engine thrust causing continued level or climb maneuvering flight and with reduced engine thrust, gravity component-thrust from descent adding to maintain that sustaining thrust.

Aircraft Attitude Effective Axes

Control is for maneuvering and requires coordination of the thrust and flight-control forces to cause desired change. All attitude change requires power coordination for maintaining the required balance of all vertical lift force components to prevent descent by gravity.

Aircraft attitude maneuvering occurs around the effective axes of rotation, relative to the current load. These axes of motion are not the axes of static balance, but always relate to the current load.

The maneuvering axes of rotation of an aircraft are three imaginary lines, perpendicular to each other, referenced to the direction of the aircraft motion.

There is the effective longitudinal axis, which passes through the center of pressure in the direction of motion, the yaw axis up and down

through the top and bottom of the fuselage, and the lateral (transverse) axis, which passes through the sides of the fuselage and wings. These axes are perpendicular to each other, intersect at the center of pressure, and relate to the maneuvering of the airplane.

Maneuvering is a function of controlling your aircraft, directing the thrust about these three axes of the aircraft. You control pitch attitude for orientation of the airplane's effective longitudinal axis, by rotation about the lateral axis.

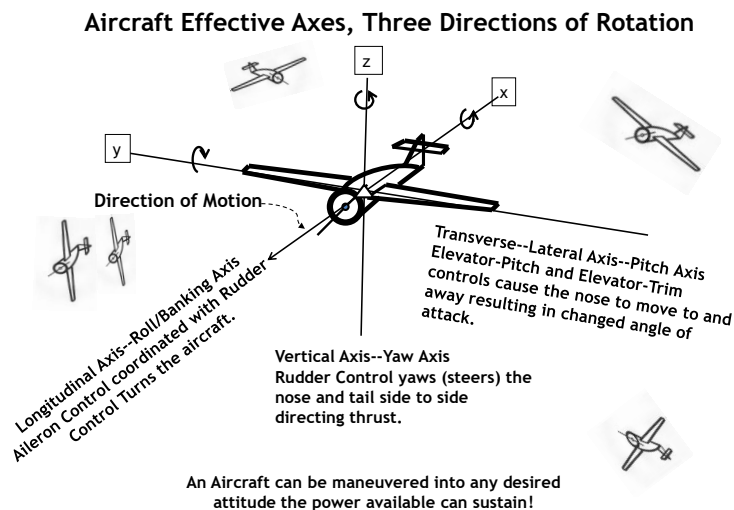

Fig.1-15

Roll is attitude rotation around the effective longitudinal axis. Aileron input with banking/rolling creates lateral component lifting as a side force, which turns the airplane.

The rudder provides side motion of the fuselage nose and tail rotating around the effective vertical axis from rudder input. This side pitching (yaw) of the engine, steers the direction of thrust, allowing coordination of any undesired turning forces from the engine and propeller rotation, or induced aerodynamic drag.

Dimensional Axes

The dimensional axes of attitude are perpendicular to each other, all passing through the static center of gravity, and describe the orientation of your aircraft as related to the earth. The longitudinal axis centered from nose to tail, the lateral axis from the wing tips, and the vertical axis out the top and bottom of the aircraft.

Pitch angle is the angle between the horizon and the static longitudinal axis. Roll is the angle of bank as referenced to the horizon. Directional attitude (side-pitch) is the compass-heading angle as referenced to the

earth from magnetic north. The close relationship of normal aircraft attitude relative to the earth has caused many pilots to consider aircraft attitude effective axes and dimensional axes the same.

Stability

Stability is the tendency of the aircraft to maintain a constant attitude. Positive stability is the tendency, if disturbed from the constant attitude, to return to that constant attitude.

Loading the aircraft with the static center-of-mass slightly ahead of the designed center of aerodynamic lift is a condition of positive stability. This creates a forward moment and its moment arm relative the center of pressure.

In this way, balancing the angle-of-attack with small aerodynamic loading of the stabilizer at the tail, with its long moment arm, assures nose down pitching and acceleration if inadvertent slowed indicated-air speed reduces that tail loading.

Minimum Safe Indicated-Air speed Flight and Descents

Slowing below optimum indicated-air speed requires increased angle-of-attack and related aerodynamic component-induced drag. There is increased mass airflow under the wing and related added voiding of air over the top of the wing.

Without care, maneuvering at low indicated-air speed high angles of attack can inadvertently reach the critical wing angle-of-attack and allow stall. Slow indicated-air speed below maximum endurance (V_{me}) level or climbing maneuvers require careful use of increased power to avoid increasing the angle-of-attack to the stalling indicated-air speed.

Visual reference of flight attitude for controlling angle-of-attack in turns is not possible. There are no inflight visual references to indicate the aircraft longitudinal pitch angle in turn, whether level, climbing, or descending.

There is a long history of low indicated-air speed maneuvering turns to final landing approach leading to stall. The pilot must train to be aware of limiting manual aft elevator-pitch in slow indicated-air speed turns. This maneuvering is common and normal for most landing approaches so pilot awareness of proper control use when maneuvering at slow indicated-air speed is imperative.

Pilots learning hands-off flight techniques can more easily fly with minimum or no elevator input when slow. This desirable technique allows safer low altitude maneuvering, approach, and landing procedures. Just use power for its lift control.

“g” Forces/Load Factor

The cause of aerodynamic “g” loading is from aerodynamic tail loading for aircraft longitudinal balance and any added aerodynamic lifting by pulling the control wheel to sustain rapid attitude change.

When maneuvering in level or climbing turning flight, it requires increasing the total lift forces. This is to overcome the increased “g” force loading for maintaining level flight. The aircraft must continually create lift to maintain the weight of the aircraft in the vertical direction plus the added turning (centripetal) side loading (“g” force), the aerodynamic tail loading, and overcoming added induced drag force.

All these forces above the weight of the aircraft are increases of total load. Load factor is a reference to the force of gravity and is relative to one “g” equaling the weight of the aircraft. Loading measured relative to the weight of a system is load factor. A load factor of two “g’s” means two times the weight of a system.

The lift, out of the top of the aircraft, in a 30 degree banked level turn, will require a 1.15 “g” load factor for sustaining the mass of the aircraft 1“g” vertical lift component. ($\sin 30^\circ = .5$, $\cos 30^\circ = .866$)

There is a significant difference in wing loading during a turn depending on the control inputs used. A turn using aft elevator control increasing angle-of-attack, using momentum and slowing for maintaining level flight is causing increased loading on the wings. The thirty-degree banked turn will have 1.15 “g” loading on the wings. This increased loading also causes increase of the indicated-airspeed at which stall can occur.

A turn using coordinated thrust-component increase (added power) to maintain level flight will have a 1 “g” load on the wings and the added .15 “g” load carried by the engine-lifting along the fuselage, its moment arm, to the center of lift.

A turn without power increase but with ample altitude to allow descent can be with minimized “g” loading. A descending turn can have little or no increased “g” loading, even negative “g” with accompanying acceleration using gravity component-thrust as excess to the sustaining thrust. This means accepting the associated altitude loss during such maneuvering.

A method of steep banked turning is a full or constant power turning zoom climb with elevator-pitch and coordinated rudder steering allowing deceleration of momentum. Then, continuing the turn as the nose will drop with the slowing. Release or push the elevator control to allow gravity acceleration back toward the set indicated-airspeed while continuing the rolled attitude, all while coordinating rudder steering to

pitch the nose down for the added gravity component-thrust of descent.

This technique is called a wing-over and is similar to the entry of a lazy eight maneuver and though not a level turn, when releasing elevator-pitch input, gravity acceleration and rudder input reduces the pitch angle and increases indicated-air speed back to the initial condition. This allows reduced “g” loading of the wings and steeper banked turns.

Glide

A partial glide with reduced thrust from an operating engine is similar to engine out gliding. There is always a minimum thrust effect at idle power, but control procedures are essentially the same as if there were no engine thrust.

When reducing or closing the throttle, the engine thrust component-lift reduces longitudinal pitch coordinated with the elevator control. Elevator-pitch controls the indicated-air speed, and with pilot adjustment, maintains the desired indicated-air speed. Supplementing to maintain sustaining thrust at the pitched indicated-air speed is gravity component-thrust. This now requires continuous descent to maintain the gravity component-thrust input. The descent rate will be that which maintains the indicated-air speed.

From our previous example requiring 160 pounds of thrust to sustain the flight, now with the engine out, our aircraft has only its 1,600-pound vertical gravity force as a thrust source. It now requires controlling to an approximate six-degree angle of descent ($\sin 6^\circ = .1$) or if descending with idle thrust of approximately 80 pounds, it will require an approximate three-degree angle of descent ($\sin 3^\circ = .05$).

Indicated-Air speed

Indicated-air speed is a relative velocity through the air! You have an indicator in the cockpit calibrated to read speed in miles/knots per hour. This indicator has a pointer that moves to indicate a current speed called indicated-air speed.

This is only an indication of a speed. The indicated-air speed instrument senses air pressure from a forward facing, open ended, tube, rammed with the mass-of-the air from forward motion of flight. This is a pitot system (invented by “Henri Pitot; 1723”), for measuring air pressure from motion, yet in the aircraft instrument calibration is displayed as speed.

The indicated-air speed indicator is merely sensing the ram-air pressure. The instrument actuation is pressure from this motion into the air mass. However, this instrument calibration is in units of speed, so called an indicated-air speed indicator (IAS).

Measurement of the pressure into the pitot system is an indication to you, the pilot, of the relative mass pressures around the surfaces of the aircraft causing generation of aerodynamic lift. Indicated-airspeed pressure is a reference of the condition of attaining and sustaining the flight. You control the aircraft as related to the instrument reading of this air pressure-speed indication.

When your aircraft is sitting on the ground, the real wind of a moving air mass can create some pressure, just as if the aircraft were moving. For this reason, if you take off, accelerating into a real wind, it requires less actual velocity over the ground and results in reduced takeoff roll to attain the indicated-airspeed pressure to cause flight.

During the takeoff roll, your accelerating aircraft creates air mass pressure from the increasingly rapid encountering and displacement of its volume through the air. Generation of reactive vertical component forces take place due to the aerodynamic shape, and these increase with increased velocity to the extent, they become equal to the weight of the aircraft.

The indicated-airspeed pressure is your primary indication of satisfactory operation of the aircraft motion. The indicated-airspeeds published for an aircraft are the only operational basis a pilot has of an aircraft without conducting actual flight test.

Elevator-pitch can be set for a constant indicated-airspeed with the elevator trim control. The trim control adjusts the elevator position to maintain a constant angle-of-attack with minimum pilot elevator control input.

True Airspeed and Groundspeed

An air mass is a large portion of the atmosphere that has similar properties of temperature, pressure, and humidity. An air mass moves relative the surface as the earth rotates underneath while warm air rises over colder air so flows with temperature differences into other air masses. Air mass movement relative the surface is the “real wind”.

An air mass carries the suspended aircraft in its direction of motion. True-airspeed is the velocity of travel and relative to the distance of travel over time within and relative to the current air mass.

Groundspeed is the velocity over the surface. A moving air mass drifts the aircraft in the direction of its movement affecting the actual track over the surface.

Density of the mass-of-the-air varies considerably with altitude, temperature, and humidity. Low-density air has reduced mass per unit volume.

The aircraft is required to travel at velocities sufficient to maintain the constant indicated-airspeed pressure necessary to sustain its lift. You

can see then, true airspeed relates to the mass per unit volume of the air. The less mass in a unit volume, the greater velocity required to attain the necessary mass displacement to cause the constant lifting pressure required.

It is necessary to take care when talking about airflow. It requires specific distinction if talking about volume of air (volume airflow) or mass of air (mass airflow) and the related effect on the aircraft from its motion or the power available.

Lift Pressure and Wing Loading

A simplified example of wing loading pressures: As noted in figure 1-4, the frontal air mass encountering pressure at 60-65 knots indicated-air speed is approximately one pound per square inch. At 60-65 knot V_y optimum indicated-air speed, there will be approximately a 6-degree wing angle-of-attack (sine 6-degrees = .1). A 1,620 lb. aircraft with two wings, each measuring 12.5 ft. long (25') x 4.5 ft. wide, will have a wing frontal area encountering the mass-of-the-air of 300 in. (25' x 12") x 5.4 in. (54" x .1) = 1,620 sq. in.

At the V_y indicated-air speed, approximately one-half of the oncoming air mass passes over the top of the wing and one-half under the wing.

Lift occurs in two ways. The portion of air mass passing over the top curved surface deflects down along the surface by the Coanda Effect, and accelerates across the partially voided surface area by the Bernoulli Effect with resulting reduced pressure over the top surface.

The air mass passing under the wing deflects slightly away with reactive upward pressure by the Newtonian Effect; the resulting combined pressure differential is the aerodynamic lift of the wing.

The underside of the example wings is 300 in. long. x 54 in. wide = 16,200 sq. in. At the same 6-degree angle-of-attack reacting under the wings with .1 lbs./sq. in. of lift, (not considering any body lifting), one hundred forty-four (144 sq. in. /sq. ft.) with 112.5 sq. ft. x .1 lb. /sq. in. = 11.25 lb./sq. ft. wing loading.

The aerodynamic lift pressure in this example is one-tenth pound per square inch. Aircraft wings have lots of square inches of area. Wing loading is measured in pressure per square-foot (144 sq. in./1 sq. ft.).

The performance of an airfoil relates directly to the displacement pressure attained for the indicated-air speed required for flight, and not related to temperature, pressure altitude, or surface velocity. Those things contribute to the mass-of-the-air and engine performance, but aircraft performance pressure relate only to the actual encountered mass (mass flow) at any instant.

An indicated-air speed is an indication of pressure-speed in any situation, and is always an indication of current pressures affecting the

airfoils. Though calibration of the system shows indicated-airspeed, it is always measuring the pressure of the impacted/rammed air, relative to the motion of your airplane.

The calibration of the indicated-airspeed indicator is the rammed air pressure. Only on a standard day at mean sea level is indicated-airspeed the actual velocity relative to the ground. Since air density and temperatures vary significantly, the indicated-airspeed reading is seldom an accurate measurement of speed across the ground.

At increased altitudes with less dense air, the velocity relative the encountering air and the surface increases while maintaining a constant indicated-airspeed airmass pressure. For a pilot, operation at altitudes near sea level, the indicated-airspeed reading is often “close enough”. There still must be consideration of air mass movement relative to the surface, “real wind”.

Ground-effect

Operations very near the surface restrict the displacement of airmass under the wing so alters the wing upwash, downwash, and wingtip vortices and results in reduced drag. Every takeoff and landing passes through this ground-effect.

Ground-effect relates to the height of the wing above the ground, so there is considerable difference with high-wing versus low-wing aircraft.

At takeoff, ground-effect starts and is greatest at liftoff and decreases with increased altitude, essentially disappearing when above an approximate altitude of the wingspan. The wingspan of most small aircraft is less than 30-40 feet.

Keeping the aircraft very low allows faster and safer acceleration to desired climbing indicated-airspeeds.

At landing, when approaching very near touchdown, this reduced drag can cause floating if the approach indicated-airspeed is too high.

Ground-effect is present anytime the aircraft is very near the surface, and is not restricted to being over the runway. Very low-level flight during an approach for landing can extend gliding distance by utilizing ground-effect, or at takeoff; continued very low-level flight after passing the runway end will allow continued acceleration to safer climb indicated-airspeeds.

A pilot must train to fly an aircraft low to the ground learning to utilize this phenomenon for extending glide distance when approaching a landing area, or to utilize the technique of remaining low for increased acceleration at takeoff from short, soft, or high-altitude runways.

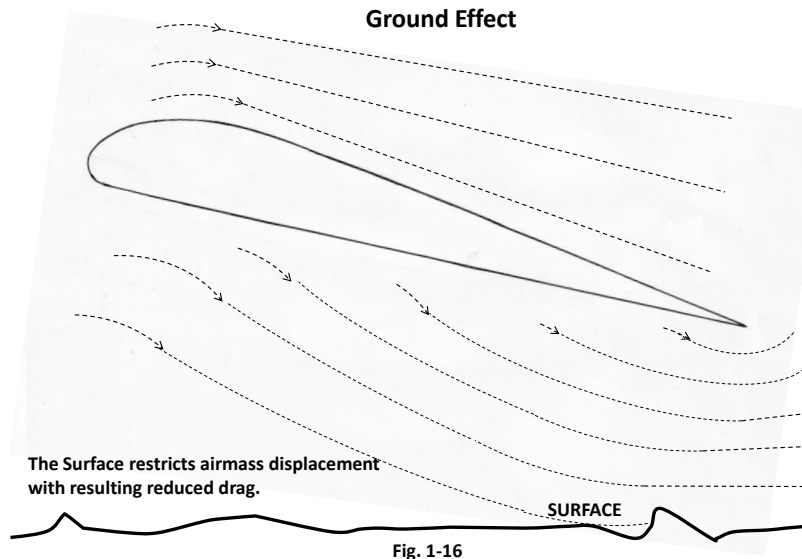

Being close to the rocks and trees could be an unnerving experience if not familiar with techniques of very low flight. All pilots should practice experiencing the phenomenon.

Estimating Wind Components

Crosswinds are components of wind affecting the direction of travel over the surface. Simple and quick mental estimates of crosswinds and head or tailwinds are easily calculated using three numbers, .5, .7, and .9. This is something any pilot can use for determining “close enough” crosswind conditions.

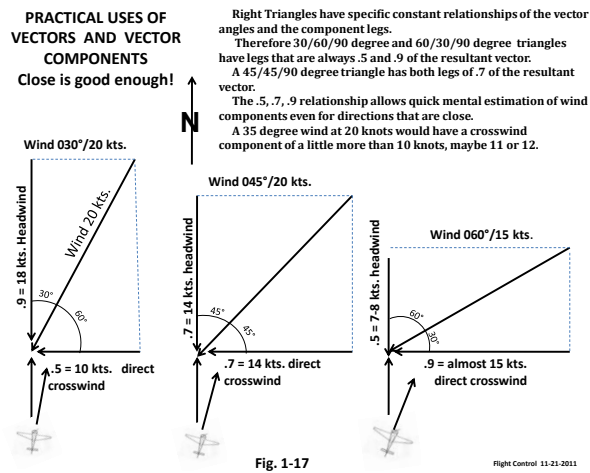

A reported 10-knot wind 25-35 degrees away from the runway heading has a 5-knot effective crosswind component ($\text{sine } 30^\circ = .5$) and a 9-knot effective headwind component ($\text{cosine } 30^\circ = .9$ [approx.]).

A 20-knot wind, 50-70 degrees away, will have an 18-knot crosswind ($\text{sine } 60^\circ = .9$ [approx.]) and 10-knot headwind ($\text{cosine } 60^\circ = .5$). A 20-knot wind 40-50 degrees away will have 14-knots of both crosswind and headwind components ($\text{sine and cosine } 45^\circ = .7$), plus or minus 3 or 4 or 5 knots, close is good enough. When attaining initial information for the landing airport, making this quick mental calculation before a landing approach allows you to have a plan.



Chapter 2-----FLIGHT MANEUVERING

Engineers designed your airplane to be aerodynamic and manufacturers built it to fly. It is a big chunk of aluminum sitting there. You cannot change that. You just deal with it. If started and turned loose, it could fly by itself, so what is all the fuss about?

We now have an idea of how airplanes fly, but we don't need to concern ourselves how or why since they do that all by themselves. A pilot needs to let them fly merely using control input for pointing them in a desired direction, trimming them up hands-off, and letting it happen.

How Does An Airplane Fly?

In flight, pilot input to a control initiates a change of attitude. The actual response involves reaction to the applied forces with associated change of momentum to a new direction. This means change is not necessarily immediate, though from the pilot's perspective, a control input gives a certain response but it normally takes a little time for completing the reaction.

Don't worry about it. Understand that all maneuvering is pilot input to the flight controls and power change, the attitude changes take a little time. You just like to know what inputs will get the desired results.

Your job as pilot is the utilization of energy through thrust for motion to enable safe, controlled flight. Your airplane uses the potential energy from fuel, converted by the engine for power, developing thrust to attain the kinetic energy of motion to sustain flight at altitude. When airborne there becomes related potential energy of gravity from position, which with gravity component-thrust of descent sustains the flight. A pilot steers the direction of thrust to obtain desired direction of motion.

Control

All ground operation, taxiing, takeoff-roll (acceleration to high velocity), and after landing touchdown-roll (landing deceleration) to parking, involves usual two-dimensional ground maneuvering of an aircraft as any other machine.

The ground steering control is with either manual rudder pedal actuation of nose-wheel steering or individual toe operated main wheel braking. Motion control is with hand throttle adjustment of thrust from the engine and wheel braking drag to slow. Ground maneuvering continues from start of taxi through acceleration of the takeoff roll and liftoff, then resumes at touchdown to parking.

The high power setting for takeoff accelerates the aircraft on the ground until attaining sufficient aerodynamic lift for flight. Aerodynamic flight control gradually becomes effective as the relative-wind increases during takeoff acceleration.

The increased relative-wind allows steering control with aerodynamic forces from pilot input to the flight controls; the elevator pitching the nose (up/to or down/away), the rudder yaw (side-pitch steering thrust), and ailerons rolling the attitude causing a turning side component-force (side lift from aerodynamic and engine thrust-component lifting).

It is the instant becoming airborne that maneuvering in three dimensions begins. Immediately upon attaining lift-off, acceleration stops, and the excess thrust applied begins climb. There is now significant change in control response from any power change. Further acceleration requires reduced elevator loading, pitch away.

Upon becoming airborne, there has become engine thrust component-lift adding to the elevator's longitudinal pitch control of angle-of-attack (indicated-airspeed) and the excess thrust component-lift is causing climb-pitch. The excess thrust component-direction of motion sustains the direction of the climb.

Flight control maneuvering of the aircraft is steering the direction of engine and gravity component-thrusts and their related component forces for maintaining or changing of attitude.

Transfer Of Energy (Energy Management)

It is the thrust, from the reaction of blasting large volumes of the mass-of-the-air, which pushes or pulls your aircraft.

Usual discussion in the industry has always related to jet engine motivation with thrust and reciprocating engine motivation with power. In both cases, it is the thrust. However, this book will use the term power interchangeably for thrust as they both cause the same results. Engine power causes thrust through the turning propeller.

Engine power and gravity power are from conversion of potential energy of fuel and/or position above the surface into thrust. The reactive force of thrust causes acceleration and sustains motion. This becomes the kinetic energy of motion. When accelerated to sufficient indicated-airspeed pressure, the aircraft became airborne.

Just as in the beginning, you start the engine and turn it loose. All you do as the pilot is guide down the runway with a high power setting allowing acceleration. When attaining sufficient indicated-airspeed to generate lift equal to the weight, the airplane lifts itself becoming airborne.

Now What Is Going To Happen?

First, you become airborne. Well, the design of the airplane is to do that, if it goes fast enough. Now it is in the air. It requires continuous sustaining thrust, and control for direction to go somewhere. It needs to climb to some higher altitude, so it does not run into anything.

You have lots of power. You became airborne after accelerating to a selected indicated-airspeed. Now you are climbing. You are converting excess energy of engine thrust by climbing to increase the potential energy of altitude from gravity.

We now have available power sources from both, the engine and gravity. The engine consumes potential energy of fuel with combustion causing thrust for motion (kinetic energy), and gravity consumes potential energy of altitude causing thrust for continued motion (kinetic energy) with descent.

Flight Controls

The flight controls are panel devices hinged to the backsides (trailing edges) of the aircraft wings and empennage.

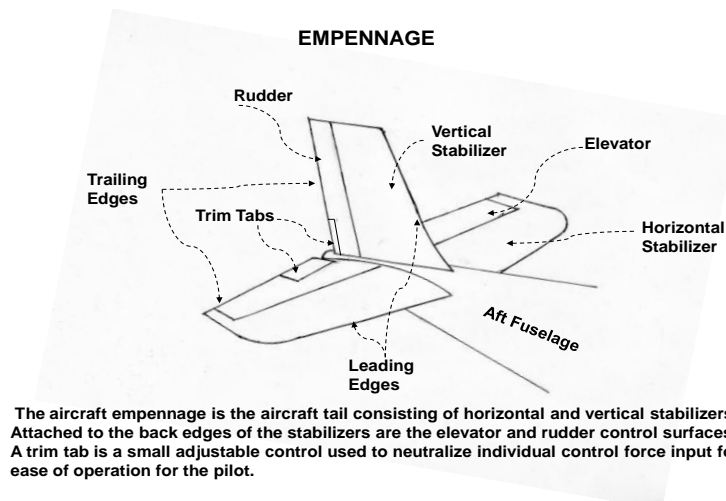

Fig 2-1

The empennage is the tail of the aircraft and all its components consisting of the vertical and horizontal stabilizers with the rudder and elevator. The controllable stabilizers enable maintaining flight stability somewhat similar to feathers on an arrow, but with pilot input allowing steering for attitude change.

The aircraft flight controls, the Ailerons, Rudder, and Elevator, maneuver the aircraft changing the direction of thrust by using aerodynamically generated forces through moment arms around the center of pressure. Input to the flight control devices deflects the

control panels into the airstream causing reactive forces directing change of direction of the aircraft thrust.

Ailerons

The ailerons are the movable surfaces mounted along the outer wing trailing edges. When turning the control wheel, the ailerons move in opposite directions into the airflow increasing lift on one wing, and decreasing lift on the opposite wing causing unbalanced lift for banking/rolling the attitude.

Turning of the control wheel in the cockpit controls the rate and extent of roll attitude change. Turning the control wheel counter-clockwise will cause the aircraft attitude to roll/bank to the left, and turning clockwise, the aircraft attitude will roll/bank to the right.

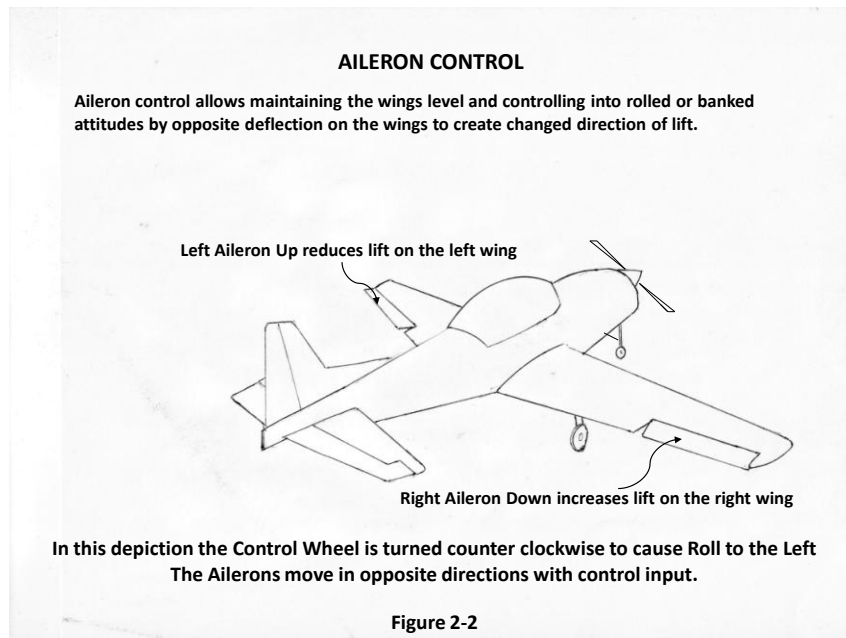

On the ground, rudder steering with nose-wheel tire to ground friction and individual main-wheel braking steers the machine. In the air, side components of lift from a rolled attitude turn the machine and rudder yawing steers the direction of thrust to coordinate any adverse forces.

When the aircraft attitude is at a wings level, constant altitude, there are vertical aerodynamic component-forces lifting from the top of the wings and body to sustain the aircraft weight.

A rolled/banked attitude of your aircraft changes the direction of the lift forces relative the direction of gravity. The rolled attitude creates a turning force from both the side directed aerodynamic component-lift and the thrust component-lift. This change reduces the vertical

component-lift forces opposing gravity, so the aircraft will begin descent unless adding sufficient coordinated power to retain a constant vertical lifting force.

The deflected aileron of the outer wing may cause some drag (adverse yaw) to the turn. It normally requires coordinated rudder steering to compensate for this drag. Additionally, the engine and propeller cause gyroscopic roll forces also requiring coordination of control from rudder steering of the thrust.

Rudder

The rudder is a movable surface mounted on the trailing edge of the vertical stabilizer. It deflects from side to side into the airflow by pilot input to foot pedals.

Most aircraft have individual main wheel braking and nose-wheel steering associated with the rudder pedals for ground taxi steering and braking.

Pushing the left rudder pedal deflects the rudder control surface to yaw/steer/side-pitch the nose to left, and pushing the right rudder pedal deflects the rudder control surface to cause the nose to yaw/steer/side-pitch to the right. For ground operation, all taxiing from the ramp departure to lift-off and landing touchdown to parking, rudder and wheel brakes control steering the direction of motion.

The engine thrust is always in the direction the nose faces. Changing the direction of the nose changes the direction of thrust force. Rudder control input is yawing to side-pitch for coordinating the thrust. The yaw of the rudder steers thrust and the rolled attitude from of the ailerons causes turn.

In a turn, miscellaneous left turning forces occur. Most undesired turning forces typically require right rudder input for coordination...for the pilot, whatever it takes. Varied rudder input coordinates the travel by directing engine thrust as necessary.

In an increasing bank/rolled attitude, the rudder pitching forces gradually contribute nose up/down pitch control. In steep turns and acrobatic maneuvering, when attaining bank angles greater than forty-five degrees, the rudder becomes a factor for vertical pitch control, up/down control of thrust relative the opposing gravity.

Elevator

The elevator is a movable control surface attached to the trailing edge of the horizontal stabilizer. Pulling and pushing the control wheel deflects it into the airflow. This causes the nose to move to and away from the pilot as a pitch attitude change for steering the thrust. Pilot input to the elevator control is elevator-pitched attitude control.

Pulling the elevator control causes an increased aerodynamic load (negative lift) to occur on the tail surface. Additionally, changed power affects the propeller-blast airflow, which depending on the specific horizontal stabilizer placement can cause some changed load on the tail.

Changed tail loading changes both, the balance of the aircraft and total effective loading. This elevator and stabilizer aerodynamic loading causes a small rotation around the lateral axis acting on its fuselage moment arm from the tail and creates a new center of pressure.

The direction of motion does not necessarily change significantly. Any attitude change causing indicated-airspeed change causes a change of the vertical component-lift. Without coordinated increase of engine thrust component-lift, altitude will decrease, as gravity component-thrust will do the power coordinating for you.

Pushing the elevator control reduces aerodynamic tail loading, even creating aerodynamic lift on the tail if mass loading is far aft. Any changed attitude of elevator-pitched angle changes the frontal profile of the fuselage and wings encountering the air-stream.

A change of frontal area of the aircraft results in an associated increased or decreased volume of displacing air. This allows the aircraft to decelerate or accelerate, as there becomes corresponding change of the required encountering air pressure per square inch for developing the constant aerodynamic lift.

For a pilot, elevator control input allows increase or decrease of indicated-airspeed. When maneuvering below V_y indicated-airspeed, cautious aft input is required to avoid extreme angles of attack possibly leading to stall.

Elevator and Horizontal Stabilizer Trim

Elevator-pitch for an indicated-airspeed can be set manually with control wheel input, but is not convenient since it would require you to hold the control in the same position for long periods.

Therefore, you can use adjustment of the elevator trim control to set a fixed elevator-pitch angle at the elevator control for minimum manual pressure. This allows the aircraft to fly at a constant indicated-airspeed with minor pilot input to the elevator control.

Some aircraft have moveable horizontal stabilizers that trim to change the angle-of-attack. These systems with horizontal stabilizer trim result in the same control as elevator-pitch trim.

An interesting thing about an elevator trim-control setting is that it does not change without the pilot resetting the trim control. If controlling the airplane with manual elevator-pitch control input and then releasing that manual input, the aircraft will attempt to resume

the indicated-airspeed related of the current elevator-pitch trimmed position. It is similar to a “cruise control”.

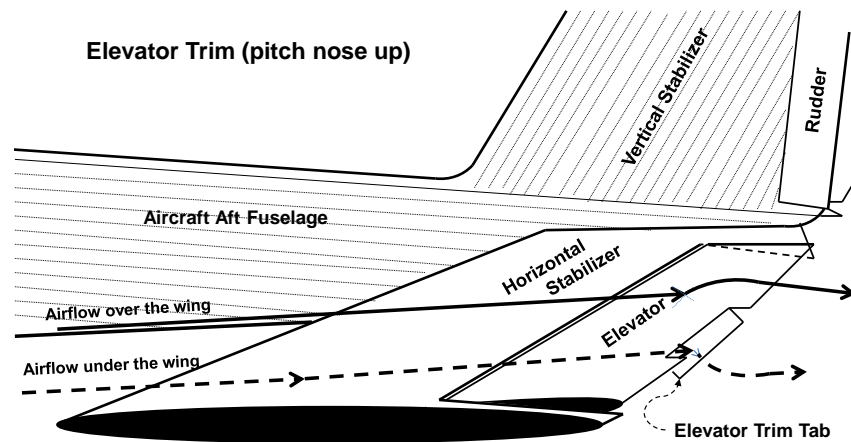

Back Elevator Control rotates the elevator trailing edge up into the airstream causing downward force on the stabilizer and resulting pitch up nose attitude as the aircraft rotates around the lateral axis.

The Elevator trim tab moved down into the airstream causes added upward force on the elevator to hold the elevator up position. The trim tab allows adjusting for a hands-off fixed position setting a specific airspeed angle of attack.

Fig. 2-3

Throttle and Mixture Control

Manual throttle control adjusts the engine power/thrust output and a manual mixture control adjusts the fuel/air ratio for proper burning. This enables coordination of optimum power from fuel combustion with any power change. For the pilot, when the aircraft is airborne, the throttle controls lift.

Engine Mounting and Control

Tractor mounted engines have thrust component-lift acting from the point of attachment forward of the center of pressure causing nose up pitch with increased thrust and nose down pitch with decreased thrust.

Pusher mounted engines have their thrust component-lift acting from the point of attachment aft of the center of pressure, so pitch the nose down with thrust increase, and nose up pitch with thrust decrease.

There are significant differences in normal maneuvering control depending on the location of the engine mounting. Most aircraft and essentially all training aircraft have tractor-mounted engines. All flight control discussion in this book is reference to tractor-mounted engines.

Pusher aircraft control is simpler to describe, as it requires continuous coordination of both thrust and elevator pitch with any attitude or power change throughout all realms of flight. Both, a change of power or a change of elevator pitch affects the total lift at the tail. The two lift inputs require coordination to maintain a constant angle-of-attack.

A simple method of determining your aircraft thrust effect is from slower hands-off level flight, add some power. If the nose lifts, it is a tractor; if the nose goes down, it is a pusher.

Engine Mounting Thrust Effect

Level Flight: Horizontal Movement into the Free Airstream (Relative Wind)
Attitude: 6 degrees nose up Indicated-Airspeed: V_y

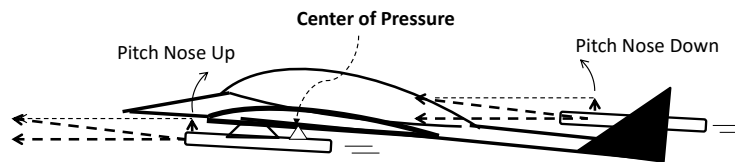

Engine mounted forward of Center-of-Pressure will rotate nose up with increased thrust component-lift. Engine mounted aft of Center of Gravity will rotate nose down with increased thrust component-lift.

Fig. 2-4

Engine Thrust Components (tractor-engine)

With most inflight operations, there is a body angle-of-attack as well as wing angle-of-attack of the travel into the free-stream air. A body angle causes the engine and its direction of thrust to be in a pitched attitude above the direction of motion so cause thrust component-vectors at the point of attachment, forward as the direction of motion and outward as lift.

Level, constant indicated-air-speed flight is a condition of engine-sustained thrust component-motion (in direction of motion) and thrust component-lift, both at the engine attachment. The engine thrust component-motion sustains the velocity of motion. The engine thrust component-lift is coordinated with the elevator-pitch causing the angle-of-attack for the current indicated-air-speed.

An increase of engine power increases the thrust component-lift creating increased pitch attitude as a climb-angle with a related changed direction of motion. That portion of thrust component-lift

from the sustained level flight remains coordinated with elevator-pitch as part of the angle-of-attack setting.

The increased portion of engine thrust component-lift causes climb angle and changes the direction of the sustaining thrust component-motion, so altitude will increase while indicated-airspeed remains approximately at the original set angle-of-attack.

Now at a climb angle up from horizontal, there is no deceleration, the added excess thrust of the thrust component-motion sustains the motion at the original indicated-airspeed in climb, and the excess engine thrust component-lift causing increased pitch angle sustains the new pitched attitude as climb angle.

The rate of climb is controllable in this manner up to the maximum thrust setting. Thereafter, reduced power and increasing true airspeed from increasing altitude (decreasing air density) will gradually reduce the climb rate.

Maneuvering

Maneuvering is controlling the aircraft attitude away from engine thrust-sustained, straight and level, constant indicated-airspeed flight.

At takeoff, the aerodynamic flight controls become effective as acceleration attains sufficient encountered airflow. Total applied engine thrust is causing acceleration.

Upon becoming airborne, the rudder, aileron, and elevator controls aerodynamically steer the direction of engine thrust. The throttle controls the extent of engine thrust effect, but there is no more acceleration, the engine thrust now *sustains* the liftoff elevator-pitched indicated-airspeed of continued flight, and any excess thrust component-lift is *causing* climb angle, the excess thrust component-forward sustains the climb rate in the direction of motion.

The elevator pitch-trim previously set for takeoff has set the angle-of-attack of air encounter for an indicated-airspeed the aircraft will fly. Manual elevator control input and trim change can override the set angle-of-attack pitch allowing any necessary indicated-airspeed adjustment.

In climbing or level flight, the throttle is the control of altitude and elevates with increased engine thrust. The elevator position controls the angle-of-attack causing frontal-plate area and allowing the indicated-airspeed the aircraft will fly.

Descent changes the relationship between power and angle-of-attack. Power reduction below level flight sustaining thrust, reduces that portion of thrust component-lift contributing to angle-of-attack so allows a small acceleration.

Change of power below level flight sustaining thrust changes angle-of-attack so now requires continuous coordination of elevator or elevator trim to maintain a constant indicated-airspeed, similar to the pusher engine control.

Flap Configuration

Positioning of flight devices such as landing gear, flaps, spoilers, etc., extended into the airstream is adjustment of configuration. Any extended device causes added drag so most operation airborne is with all devices retracted, a “clean configuration”.

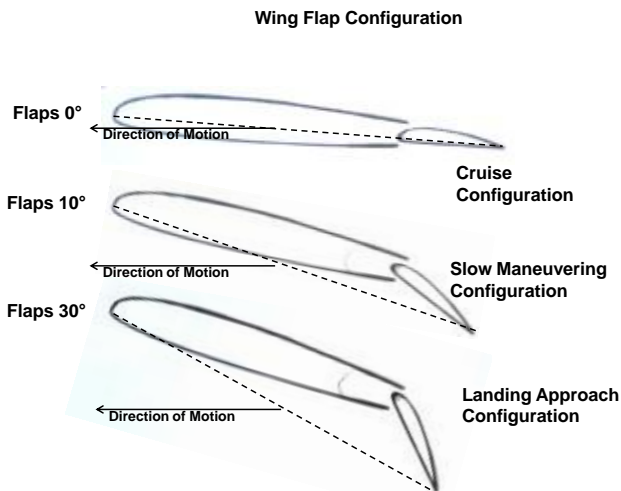

Fig 2-5

Attitude

Attitude is orientation in space. The airplane attitude is its position relative to the surface of the earth. The attitude orientation can be straight and level (wings level with constant direction, coordinated power, and altitude), straight with nose up or down for an angle of climb or descent, rolled left or right to an angle of bank, or a combination of these including, straight up, down or inverted.

A pilot should carefully consider airplane attitude. When the making a flight control input, placing the airplane into an attitude, returning the control to its neutral position stops the input, and the airplane remains in the newly selected attitude...if there is sufficient coordinated power.

The flight controls cause the airplane to change its orientation relative to the earth. They maneuver attitude change, but require coordinated engine or gravity power input to attain and maintain that change.

Although attitude can be in any orientation in space, in most aircraft, normal maneuvering is power limited to within 10-15 degrees nose up or down with reference to the horizon, and seldom more than 45-50

degrees angle of bank/roll. As the pilot, you must be aware that airplane orientation matters because of the continuous, large, gravitational force effect, and usual limited engine power available.

Pitch

There are two ways to consider pitch; aircraft attitude pitch and vertical attitude pitch. The two kinds of pitch are often confused so need clarification in discussion.

Vertical pitch is an aircraft pitched angle relative the horizon and attitude pitch is reference to input of control for changing attitude.

Pitch Angle

Pitch angle refers to the attitude of the aircraft nose relative the horizon, a vertical-pitch angle. It is a definition related to a profile attitude angle between the horizon and the aircraft dimensional longitudinal axis.

Because of power limitations, in most aircraft, the pitched attitude angle will seldom exceed 10-15 degrees nose up or down.

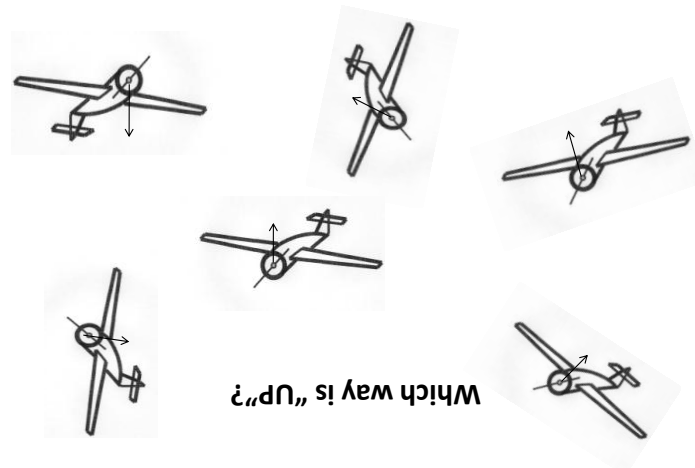

Fig. 2-6

However, in aircraft with sufficient power it is possible to have flight pitched to any given angle from level to vertically up, down, or inverted. The resulting total aircraft pitch angle from the horizon will be the excess power causing climb angle plus the body angle (aircraft angle-of-attack) of combined elevator-pitch and sustaining portion of engine thrust component-lift.

Pitch Control

Pitch control input is directing thrust, steering the machine to attain a desired direction of motion. We consider the term pitch in different ways.

Pitching the attitude refers to inputting control to cause an attitude change relative to the pilot in the cockpit. As the pilot, you pitch the aircraft nose to or away with movement of elevator-pitch control, engine thrust component-lift with power change, and side-pitch of thrust direction with rudder input.

A consideration must be made of the attitude of the aircraft when applying a pitch input. When banking the aircraft beyond forty-five degrees, the rudder input gradually becomes a vertical-pitch control. For this reason, it is necessary to consider how pitch control works in acrobatic or unusual attitude recovery flight.

Elevator-Pitch

You use the control wheel, forward and aft movement for changing the elevator aerodynamic lifting/loading. Elevator pitch adjustment results in rotation of the fuselage, with the effective longitudinal axis, around the lateral axis. Elevator or horizontal stabilizer trimming systems set a desired elevator pitch for minimizing pressures of pilot input.

In level flight, the climb angle is zero, so the horizontal stabilizer loading, coordinated with the small outward thrust component-lift of engine sustaining thrust, cause the vertical angles of aircraft pitch. This causes the vertical pitch and attitude pitch to be the same.

Rudder-Pitch

Rudder input moves the aircraft nose side-ways relative the pilot. This is steering the direction of thrust so is pitching the attitude in the direction of pilot input. When the attitude is rolled over forty-five degrees, it gradually becomes a vertical-pitch control.

Climb-Pitch

Excess thrust component-lift increases the level-flight engine lift, resulting in climb. This causes nose up/to pitching of the aircraft changing the direction of motion. The angle-of-attack pitch remains constant as previously balanced with elevator position and the sustaining portion of the engine's thrust component-lift. On some aircraft, the added propeller-blast will cause some elevator loading with increased angle-of-attack.

Climb-pitch is a changed direction of motion. A climb is movement up away from level flight with continued horizontal travel, but now along an inclined plane of increasing altitude. The increased thrust

component-forward from adding excess thrust sustains the new direction of travel.

Descent-Pitch

You are again flying in a stabilized, constant indicated-airspeed, wings level condition. What happens when you reduce power?

In level flight, the aircraft has its small outward angle of encounter with the oncoming free-stream air (wind of motion, relative wind). This, we have determined, causes the small outward lifting force of the engine thrust-component.

A decrease of thrust reduces that engine thrust component-lift contributing to the elevator set angle-of-attack. The effect is a small decrease of the aircraft angle-of-attack. This occurs anytime the engine thrust reduces from that required for sustained level flight.

Reducing engine thrust below the sustaining thrust allows the addition of gravity component-thrust to maintain the total flight sustaining thrust. This results from decreased pitch angle of aircraft attitude with descent (a negative climb angle) and allows the small acceleration from the reduction of angle-of-attack lift from level flight-sustaining engine thrust component-lift.

Maneuvering is Attitude Change

Beginning the discussion from a stabilized level flight with constant cruising V_y indicated-airspeed, and wings level, you have the indicated-airspeed set with elevator pitch trim and the power coordinated to sustain this altitude. This is hands-off flight. Your aircraft is flying by itself.

In the stabilized hands-off level flight, your aircraft has its set angle-of-attack of the fuselage and wings that has established this constant cruise indicated-airspeed. You have coordinated the engine power to sustain the constant altitude.

A typical side profile of your aircraft nose up attitude in level cruise flight at this indicated-airspeed will be at a pitched attitude of six to eight degrees. This means, if your angle-of-incidence were three degrees, there is an associated elevator-pitched body angle of three to five degrees.

At this time, your aircraft has zero climb angle and three to five degrees nose up body angle. The relative-wind is opposite the direction of motion, so is also level with the horizon.

Maneuvering in Level Flight

Constant altitude is level flight. Beginning from constant indicated-airspeed sustained wings level flight, adding only power will cause climb and reducing power will cause descent. Changing only angle-of-

attack allows acceleration or deceleration but with associated change of altitude by gravity component-thrust from descent or limited zooming climb with momentum and rapid slowing by gravity-component drag. Level flight indicated-air-speed increase requires reduced angle-of-attack to *allow* acceleration with coordinated engine thrust increase to *cause* acceleration.

If above maximum endurance (V_{me} , Loiter/maximum endurance IAS is approximately 75% of V_y) indicated-air-speed, increased angle-of-attack *allows* deceleration and when coordinated with reduced thrust *causes* level flight deceleration.

If below V_{me} , deceleration *allowed* with increased angle-of-attack and its increased induced drag requires coordinated thrust increase to *cause* sustaining level flight. This is a “behind the power curve” condition and is very close to the critical angle-of-attack.

Maneuvering with Excess Thrust (turns)

Level flight maneuvering is turning, which with its rolled attitude, reduces the vertical component-lift so requires coordinated thrust increase to sustain the constant vertical lift for level flight.

Coordinated increase of thrust, adding excess thrust, throughout a turn will maintain the lift balance with associated increased engine thrust component-lift while traveling level along an angled plane. The angle-of-attack set indicated-air-speed will remain constant.

Some propeller aircraft may have increased downwash effect from blasting air when thrust is increased. This will cause some slowing from increased elevator loading and the related increased angle-of-attack.

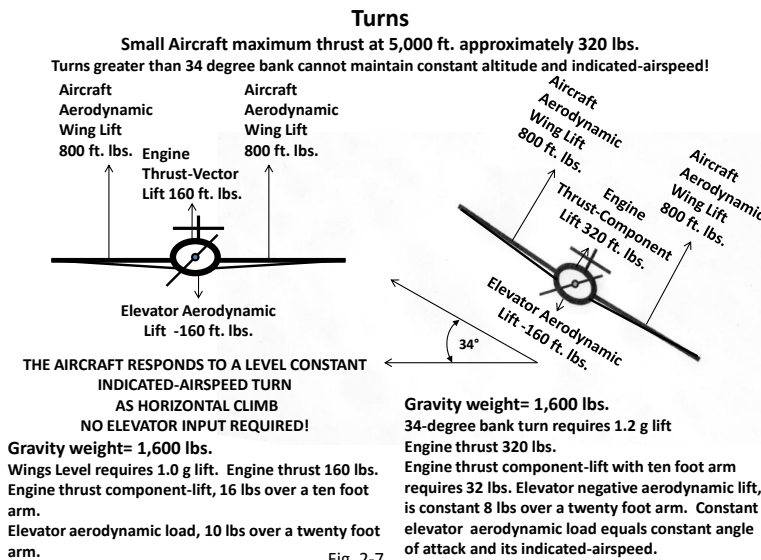

The level, constant indicated-airspeed turning maneuver, increases the effective structural gross weight of the aircraft. Level or climb turning flight requires added power to carry this load. Most small aircraft do not have enough power to sustain more than a 30-40 degree banked level constant indicated-airspeed turn.

Use of gradual increased aft elevator-pitch when turning will add some lift to allow level flight. However, this increases angle-of-attack, slows the aircraft, increases "g" loading on the wings, and increases stall indicated-airspeed. Therefore, steeper banked turning with increased pitch requires cautious consideration that there is sufficient indicated-airspeed to allow increasing lift in this manner.

A 30 degree banked level turn at our constant 65-knot V_y will cause a 1,600-pound aircraft to lose some of its vertical-component lift plus, for maintaining level flight, requires more power to offset the increased "g" loading. In this 1.15 "g" turn, the aircraft requires a total lift of 1840 pounds ($\cosine 30^\circ = .866$), to sustain the 1,600-pound vertical lift.

This constant indicated-airspeed and constant aerodynamic lift, requires an increase of $8\pm$ pounds of engine thrust component-lift on its ten-foot moment arm.

Coordinating power from 160 to 240 pounds of thrust while in this attitude increases total lift for the level turn. For a pilot, there is no reading of thrust applied, just roll into and out of the turns, visually acquiring and maintaining the travel of the nose level across the horizon with coordinated thrust as required.

Lift Forces and Their Component Vertical and Horizontal Forces

Maximum Power Constant Indicated-Airspeed Level Turn
1600 lb. Aircraft, 32 lb. Engine Lift, 1.2 "g" 34° Bank Requires 1920 lb. Total Lift

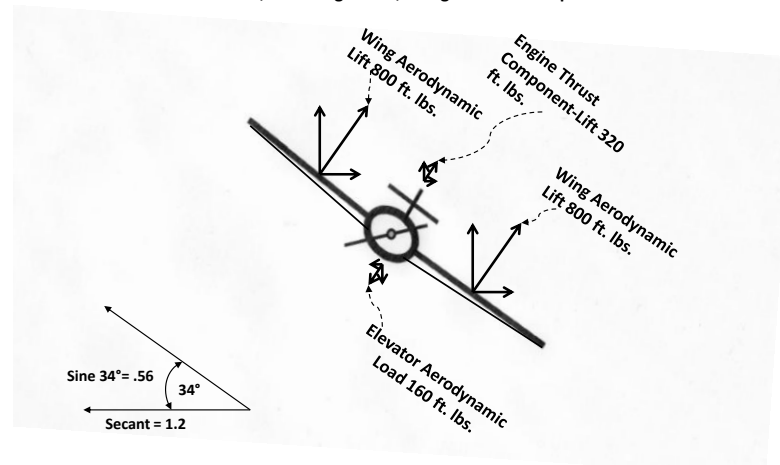

Fig. 2.8

The rolled/banked attitude of an aircraft, with the changed direction of lift has also created a side-component of the lift force. This side-component of lift is turning the aircraft. In this case, 920 pounds (sine $30^\circ = .5$) of the total force is changing the direction of flight.

The thirty degree banked level turn has caused a 1.15 “g” structural load on the aircraft. When using added thrust, there is a one “g” wing load and a .15 “g” forward fuselage load.

Maneuvering with Excess Thrust (Climb)

Excess thrust is that engine thrust applied above the level-flight sustaining power setting. It requires excess thrust to cause climb. Added thrust increases propeller-blasting air and on some aircraft may cause some aerodynamic loading change across the horizontal stabilizer and elevator. These effects vary by aircraft according to the designed structural placement of the horizontal stabilizer, but may cause some increased angle-of-attack and slowing.

In this changed attitude, for climb, the sustaining power for the current indicated-airspeed pressure remains constant. The excess thrust causes the angle of climb and sustains the upward motion.

The excess thrust also increases both the drag components of aerodynamic lift and gravity caused by the changed attitude on the direction of total lift. The increased altitude of climb results in conversion of chemical energy through the engine to an increase of the potential energy of gravity.

So what does all this mean? You have normal climb occurring at some rate of climb at the previously set elevator pitched indicated-airspeed.

Now you know an aircraft with tractor-mounted engines, if increasing power from sustained level hands-off trimmed flight and not affected by propeller-blast, the aircraft will pitch up to a climb angle and with no change to angle-of-attack, maintain the current indicated-airspeed.

Maneuvering in Descending Flight

The aircraft, in sustained level flight, is at a set angle-of-attack into the oncoming free-stream air (wind of motion, relative wind) causing a desired indicated-airspeed. The elevator-pitch has incorporated the small engine thrust-component of lift as part of the pitched angle-of-attack setting for the current attitude balance.

A decrease of this sustaining engine thrust to cause descent reduces a portion of that thrust component-lift. The effect is a small decrease of the aircraft angle-of-attack allowing some acceleration.

At the same time, reducing engine thrust creates gravity component-thrust as the attitude moves into a descending angle. This gravity

component-thrust adds to accelerate to, and maintain, the sustaining thrust at this new indicated-airspeed.

Reduced or idle power (partial gliding) and engine-out (gliding) flight requires re-setting the angle-of-attack with manual elevator-pitch control or elevator-pitch trim to maintain a desired indicated-airspeed.

All descent requires continuous coordination for both power and indicated-airspeed change. Knowledge of this relationship of engine-power lifting and elevator-pitch control when below sustaining thrust allows anticipation of attitude change with changing engine thrust.

This relationship of changing the angle-of-attack with power change when in descent is an explanation of many Pilots considering that power controls indicated-airspeed.

When flying constant indicated-airspeed approaches to landing, stabilized control allows minimum thrust change throughout, and reduces the need of large elevator-pitch inputs for maintaining constant indicated-airspeed.

In glide, the elevator control acts as gravity controller, but always with either increased rate of descent causing acceleration or reduced descent rate causing deceleration.

Maneuvering with Gravity (Engine Out)

Elevator input is the only control of gravity component-thrust. You have no throttle for gravity, only aircraft attitude. Maneuvering with elevator-pitch input to attitudes that change gravity component-thrust is the only way to throttle gravity acceleration.

Decreased elevator-pitch can cause rapid acceleration from the very large gravity force. Nose down elevator-pitch input can initiate descent, but you must exercise caution. Gravity thrust is equivalent to the gross weight of the aircraft, possibly four times the maximum engine thrust. Indicated-airspeed will increase rapidly with any elevator nose down pitch input.

The set elevator-pitch in normal flight attempts maintaining a constant indicated-airspeed due to positive dynamic stabilization, but with any low-pitched attitude, the acceleration from the gravitational component-thrust will be rapid.

Normal technique is from manual aft elevator-pitch input for slowing using the increased angle-of-attack for its induced drag. This is positive pulling of the control wheel to regain or retain indicated-airspeed control.

With large angles of descent, use of aft elevator-pitch control for more rapid deceleration will result in increased structural load factor ("g" loading), so requires careful input. The sight picture across the

windshield in this extreme example might show mostly surface and little sky.

An example: A 1,600 pound aircraft with a 6 degree descent angle having gravity component-thrust of 160 pounds (sine 6 degrees = .1), will for a 12-degree descent, have gravity component-thrust of 320 pounds (sine 12 degrees = .2), almost the equivalent of full engine power at 5,000 feet.

Acceleration can be very rapid even in shallow descents. The indicated-airspeed increase by holding down elevator-pitch could cause approaching or exceeding the never-exceed speed (V_{ne}) to the extent structural damage might occur.

The combined effect of aft elevator control and high indicated-airspeed can easily generate large loads (“g” forces) that could overstress the structure. It requires awareness to avoid excessive descent attitude and with large angles of descent (diving) careful but positive elevator-pitch control input for attitude recovery.

Gravity Effects

Engine thrust and Gravity component-thrust sustain lift by maintaining sufficient motion. Gravity is always out there, it is a substantial force, and always directed vertically down. If your vertical lift opposing gravity is not equal to the weight of the machine, then gravity component-thrust will always add to maintain the necessary sustaining force for your indicated-airspeed but you are going to descend...every time.

Gravity component-thrust will always balance the engine thrust to the sustaining indicated-airspeed for the current angle-of-attack and always with descent.

You can maneuver the aircraft into any attitude, but can only attain or sustain that attitude if there is sufficient engine thrust. An attitude that engine power alone cannot develop sustaining thrust will result in descent from gravity component-thrust, causing the aircraft to continue to fly, but at some different attitude and altitude.

You can do nothing. If unable to sustain the airplane indicated-airspeed because of engine power limitations, gravity does it for you, with descent.

If you insist on manually forcing a maneuver with aft elevator into an attitude the machine does not have the power to sustain, it will decelerate into a stall and then still descend, uncontrolled! In all cases, you will descend. Just be sure there is altitude below.

Zoom and Dive

Exercises in zoom and dive will allow a pilot to become familiar with the coordination of energy exchanges in different regimes of flight.

Zoom is limited by power available, but dive is almost unlimited by gravity so is used cautiously.

Simple wings level, constant powered, zoom can begin from a trimmed level indicated-air-speed. Holding aft elevator-pitch to zoom the aircraft up allows the indicated-air-speed to decelerate. As the aircraft decelerates, the nose will want to drop (from positive stability); gradual release of elevator-pitch allows the nose to drop with a resulting shallow dive allowing indicated-air-speed to resume toward the original elevator trimmed indicated-air-speed.

A second procedure could be with added climb power, zooming again following the same procedure as before. The release of elevator-pitch will allow a diving descent, and now will have to be coordinated with reducing the power back to the original level flight sustaining thrust. The power has caused greater altitude increase during the zoom and rapid acceleration in the dive.

This has been an energy exchange of kinetic energy to potential energy of increased altitude then exchanged back to the original kinetic energy of motion.

Continuing this type maneuvering, with initial diving by pushing the elevator-pitch for descent, there will be descent with a rapid increase of indicated-air-speed. Note how rapidly acceleration occurs from the large gravity component-thrust effect added to the sustaining engine thrust.

As indicated-air-speed increases toward V_{ne} , gradual release of the elevator-pitch input will allow the trimmed angle-of-attack with the increased kinetic energy in the aircraft to cause climb and reduce back toward the starting indicated-air-speed and altitude.

Note that with different energy losses involved, it will not regain the original altitude. The set elevator trimmed angle-of-attack and related sustaining engine thrust will resume the previous indicated-air-speed, just at a lower altitude.

The two types of maneuvers zoom/dive and dive/zoom have different results. With an initial zoom, the aircraft will return close to its original altitude. The initial dive maneuver has both engine and gravity component-thrust adding with considerable acceleration and related energy loss throughout so does not recover to the original altitude without additional climb.

Turning maneuvers (wingovers) of zoom/dive and dive/zoom will show similar behavior. These turning maneuvers at different power settings will allow familiarity with the control required in steep angled turns. This enhances a pilot's understanding of energy management for control to become proficient in altitude-exchange turns and is useful in unusual or emergency very low altitude maneuvering situations.

The turn begins by using full engine power into a climbing, banking attitude while allowing the nose to begin dropping as indicated-airspeed reduces, and the banked angle increases. With gradual release of any aft elevator control and coordinated rudder input with the turn, the slowing indicated-airspeed will cause the nose to drop through the horizon, similar to the lazy-eight entry maneuver. Coordinated rudder at this time is side pitching the nose down, and indicated-airspeed will begin accelerating.

Recovery of descent and heading is coordinated to roll out of the turn leveled at the desired altitude and heading, and with the power coordinated to sustain the original indicated-airspeed. This procedure also allows steep banked turning without excessive “g” loading.

As an emergency turn, practicing at a safe altitude using only outside visual reference at idle power will simulate engine-out turning to allow learning of a safe procedure and probable altitude required to complete. In a zoom, there is obvious slowing and changed control response. Release of any elevator-pitch input will allow natural nose down pitching from the slowed indicated-airspeed.

The coordinated turning is changing the heading and as the bank angle passes forty-five degrees, the rudder input becomes a vertical pitch control and when coordinated assures nose down pitching with any increased turning rate. The turning should be coordinated to allow rolling out of a 180-degree turn with wings level. 

Chapter 3-----VISUAL FLIGHT CONTROL

Visual flight is a method of maneuvering in relation to sighted references, a “sight picture”. You direct the aircraft into a desired attitude and maintain that attitude as related to visual reference of points on the surface or horizon and ratios of the surface to the sky using the horizon as a line across the windshield.

This is controlling toward sighted points on the horizon or ground. It involves the alignment of distant objects toward which you fly be maintained in a constant position (unmoving) relative to you and a reference point on your aircraft window. This is similar to sighting targets with a gun.

“Directed-Course” Visual Flight Control

In this book, the added term *Directed-Course* is reference to normal visual maneuvering of flight courses and attitudes. The common term *Collision Course* refers to a course relative to another in-flight aircraft or object, sighted unmoving, that could lead to an actual mid-air collision. A collision course sighting always requires you maneuver to cause the other aircraft or object to become moving relative to your aircraft.

It is essential you understand what is happening when flying a Directed-Course as an unmoving sight picture relative to the earth’s surface. A Directed-Course is toward a distant referenced object, maneuvered to be unmoving relative to your sighting alignment through a reference point on the windshield or side-window, and toward which you target your motion, however you never reach this targeted object. Prior to reaching any sighted reference, you will maneuver away toward a different targeted destination. When approaching an apparent obstacle, only visually sighted objects below the horizon are objects that you will pass over.

Pitch, roll, and yaw are the three components of control for steering your airplane's attitude. Pilot input maneuvers the aircraft attitude to attain a sight picture as an unmoving targeted point on the surface or horizon relative to the windshield, and toward which you want to fly.

You can maintain or change the indicated-airspeed, altitude, and direction (heading) of flight using the airplane flight and engine controls. The controls adjust your rate of climb or descent, and rate of turn (bank angle of travel relative the horizon). Coordination of the controls adjusts your aircraft to a desired, inflight referenced, sight picture for attaining and/or maintaining the attitude required for a maneuver.

The primary visual reference (sight picture), used in your airplane, is the relationship between the airplane's nose-cowling, or points on the windshield or side-windows, to something in the distance on the ground or horizon.

The fixed line of the horizon, sighted unmoving and level across your windshield in flight is a wings level collision course toward the horizon. A fixed point or object on the horizon, aligned to a point on the windshield for directional control, is a potential collision with that distant reference.

A descent, toward a destination on the ground, is directing your airplane onto a fixed or nonmoving referenced course (Directed-Course) toward that location on the surface. Generally, you start descent when the referenced object is sighted toward the middle or lower windshield. Practice will determine the visual point for beginning descent to achieve different rates of descent.

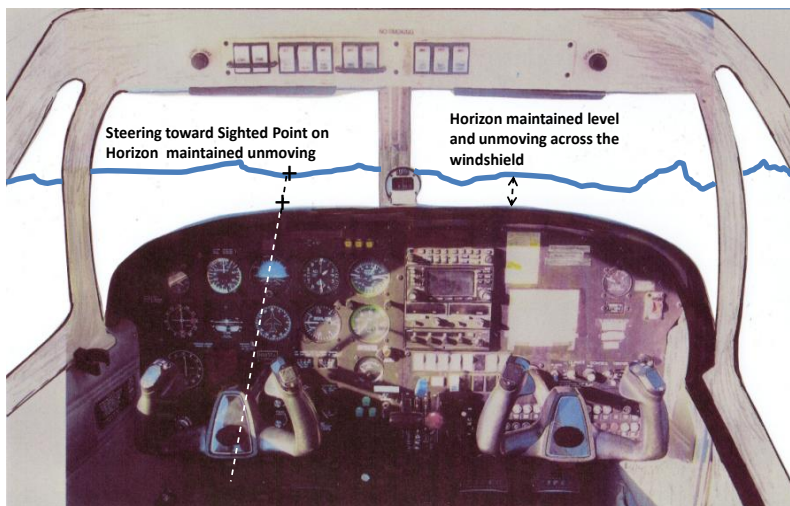

“DIRECTED COURSE” VISUAL REFERENCE FLIGHT
NORMAL CRUISE SPEED, LEVEL FLIGHT

Fig 3-1

When established on a final landing approach, the aiming point you have chosen for touchdown becomes a Visual directed-course (collision course) to that area, on or near the runway approach end.

Maneuvering attitudes are combinations of level, turning, climbing, and descending flight. The associated sight pictures allow your confirmation of proper attitude for attaining and sustaining these attitudes for flight toward a chosen direction and site.

Vertical Pitch Attitude

Vertical Pitch Attitude is the angular relationship between your aircraft and the horizon. This angular or pitched attitude is the sighted ratio of the visible sky to the ground in the view ahead through the windshield. The ratio of the sky to the ground sighted in the windshield will change with pitch angle change. It requires a new sight picture for any attitude change.

In your typical small airplane, there might be 1/3 ground and 2/3 sky with your airplane in a wings level constant altitude cruise attitude. Maintaining a distant point of reference as unmoving (no movement relative to a point on the windshield), results in desired direction of travel.

Level flight deceleration increases the vertical angle slightly, causing more sky to be visible. The sight picture of less ground to more sky occurs as the indicated-airspeed slows.

Level flight acceleration, decreases the pitch attitude, causing less sky to be visible. This changes the sight picture to more ground and less sky and happens as indicated-airspeed increases.

The same kinds of reference change will occur with climbs, descents, and turns. In all cases, there is a sight picture, which will correspond to a current pitch attitude of the airplane. Each change of attitude is a new sight picture.

You maneuver into the attitude desired, and note the visual sight picture, relative to the surface, and horizon. You then adjust the power and maneuver the flight controls, to maintain that sight picture, unmoving, relative to the targeting point on the windshield or cowling.

In any attitude, the rate of climb or descent will be dependent on the coordinated power and the indicated-airspeed as set with elevator-pitch. You can always note a related visual reference of the ratio of ground and sky.

Maintaining a fixed sight picture of the horizon requires you coordinate power for maintaining the constant pitched attitude in wings level or turning flight.

Visual Flight Attitudes

The relationship between your airplane's nose-cowling, points on the windshield and side-windows, as related to the surface and horizon, provide you primary visual reference.

In all cases, coordination of flight and engine controls causes a pitch attitude. When attaining a desired pitch attitude, there will be distant surface and horizon points that become unmoving as reference to allow maintaining this attitude.

Takeoff Attitude

Your takeoff attitude is similar to a climb attitude with a sight picture of the horizon being low, at or near the nose cowling. The actual position of the sight picture of the horizon low on the windshield will vary depending on your selected indicated-airspeed and the climb angle from excess thrust available.

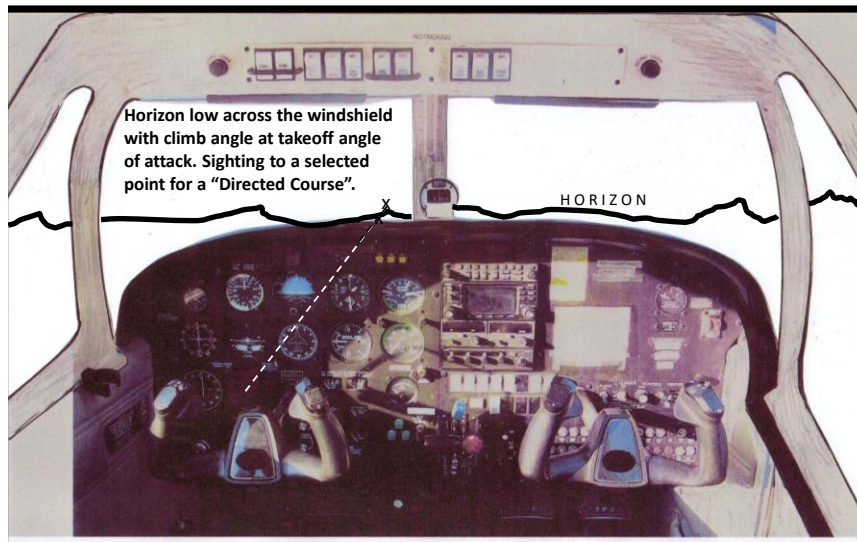

"DIRECTED COURSE" VISUAL REFERENCE FLIGHT
TAKEOFF AND CLIMBING WINGS LEVEL FLIGHT

Fig. 3-2

You also must select a point or object on or toward the horizon for directional control.

With the excess power and at the trimmed indicated-airspeed, your aircraft is attempting to maintain a constant climb at that indicated-airspeed. Rudder and aileron control will maintain the heading point constant.

Climb Attitude

To initiate, or maintain a climb, you have increased above the sustaining engine power by adding excess power. In some aircraft, depending on the placement of the horizontal stabilizer, increase in power causes increased propeller-blasting airflow over the horizontal stabilizer and elevator, resulting in added elevator aerodynamic loading and some slowing of indicated-airspeed.

For many light airplanes, the climbing sight picture will appear to have the nose cowling on, or just slightly above the horizon. When you initiate a climb, an attitude change will occur without horizontal stabilizer or elevator-pitch input, as your aircraft will attempt to

maintain its trimmed indicated-air speed (elevator-pitched angle-of-attack) previously set with the horizontal stabilizer or elevator-pitch trim.

The amount of pitch change for climb angle is dependent on the excess engine power available. Climbing into the reduced density of the atmosphere gradually limits available power, so throughout any climb, there is a gradual reduction of the climb angle and the related sight picture ground/sky ratio very slowly changes.

In all cases of attitude change, you will reference the horizon to enable attaining a sight picture for relating to the desired climb performance. With the application of excess power, your aircraft, at a constant indicated-air speed, seeks its own climb pitch angle.

Cruise Attitude

In cruise flight, your properly trimmed airplane maintains a constant indicated-air speed and altitude. The range of attitudes at different level flight indicated-air speeds is relatively small, usually being just a few degrees of pitch, and often not apparent to a pilot. The sighted horizon will be level across the windshield close to one-third to one-half up from the bottom.

Turn Attitude

Roll or bank is an angle (tilt) to the left or right of your aircraft as referenced to the horizon. You sight the angle of the horizon across the windshield. Your heading reference on the windshield is movement of the nose cowling traveling level along the horizon causing a constant altitude level turn.

If there is no increase of the vertical lift component to maintain this aircraft loading, the nose position, sighted relative to the horizon, starts down, and will result in the airplane descending, as it tries to maintain the set elevator-pitched indicated-air speed.

In order to make any level constant indicated-air speed turning flight, you must always add coordinated power. The referenced sight picture, moving level horizontally in the turn, is with controlled, constant, vertical component-lift from the coordination of added thrust.

With an understanding of the cause of lift and indicated-air speed, it soon becomes apparent that, in most turns, you do not need to pull on the control wheel. To maintain the level-flight sight picture, gradually add coordinated power as you roll the aircraft into the turn and gradually retard that power as you roll out level on a desired heading.

Perfect level, constant indicated-air speed turns can result with bank angles up to maximum power input. After reaching maximum power, steeper bank angles for level turns are not possible without elevator-pitch and resultant slowed indicated-air speed.

“DIRECTED COURSE” VISUAL REFERENCE FLIGHT

22° STANDARD RATE LEVEL LEFT TURN

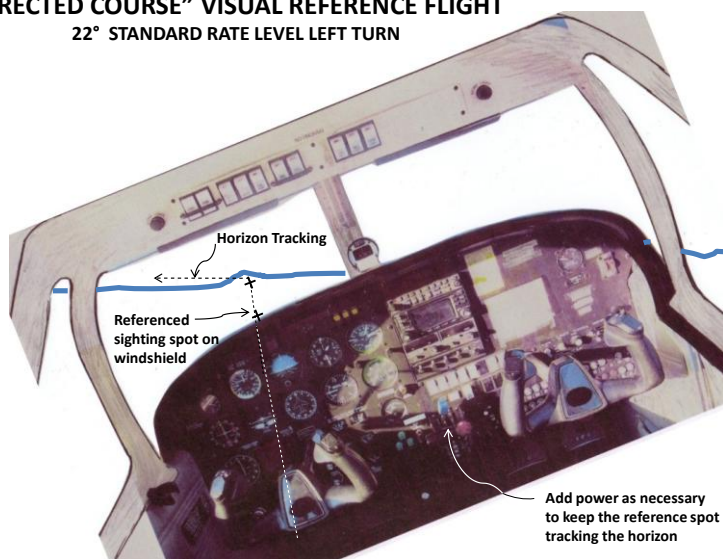

Fig. 3.3

When operating at slower indicated-airspeeds, aft elevator-pitch input in a turn increases the stalling indicated-airspeed from the added “g-force” loading and when operating at very slow indicated-airspeeds, there may be rapid approach to the critical wing angle-of-attack.

Descent attitude

To make your airplane descend (decrease altitude), you will initiate a small power reduction, which lowers the nose below that of the level cruise attitude.

Normal descent will occur with the nose lowering from reduction of engine thrust component-lift. For most light airplanes, this will become a sight picture at which the airplane nose appears to be close or slightly below the horizon.

Power reduction for descent reduces the powered lift portion of the indicated-airspeed angle-of-attack as set with elevator-pitch. Also in some aircraft, the decrease of propeller-blast loading on the elevator may result in a small increase of indicated-airspeed.

Visually fixing your descent destination as a Directed-Course, unmoving, near the bottom center of the windshield, enables you to fly a descent path directly to that destination. Adjustment of power will keep your destination point fixed, and the airplane will continue at the elevator-pitched indicated-airspeed as coordinated with the elevator trim.

Visual Descent to a Destination

Constant Indicated-Airspeed

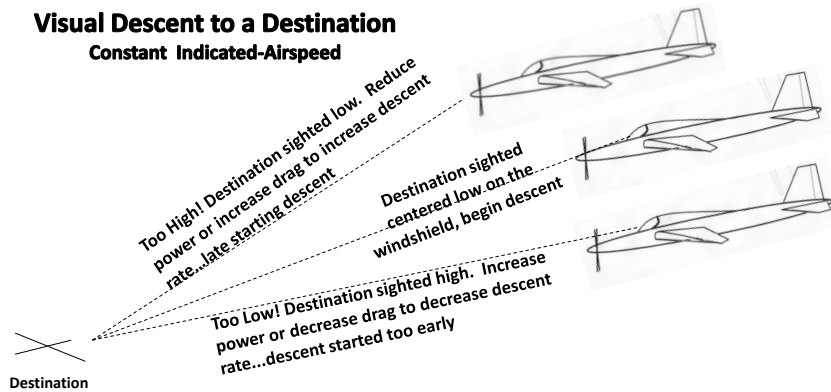

Elevator-Pitch trimmed to a desired descent indicated-airspeed. Visual descent; idle-power, partial powered, or engine-out to a destination.

Fig. 3-4

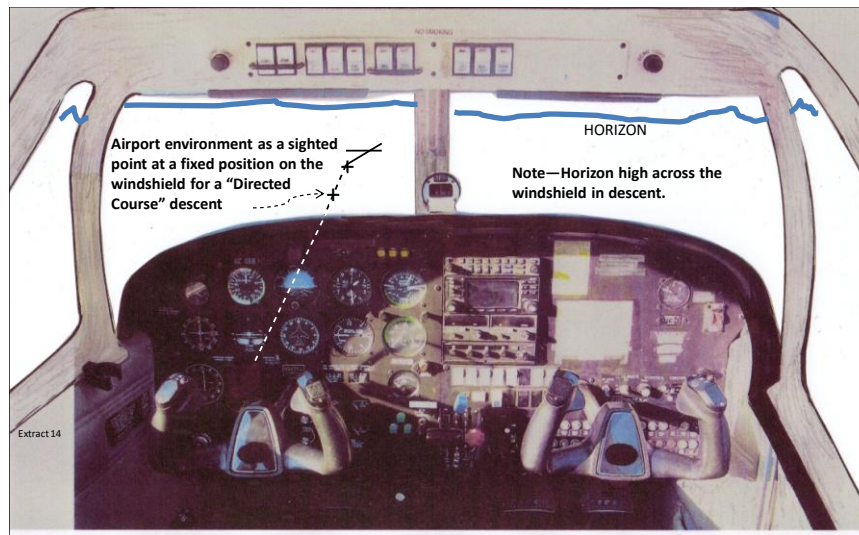

"DIRECTED COURSE" VISUAL REFERENCE FLIGHT

Descent Toward Distant Destination

Fig. 3-5

The start of descent will be when the sighted destination has moved toward the lower side of the windshield. A small reduction of power will maintain that sight picture. The sight picture across the windshield in this example might show mostly surface and little sky.

This type descent will have the aircraft altitude approaching the traffic pattern altitude approximately 1-2 miles from the destination.

Approach Descent Attitude

In the traffic pattern, a normal pattern flies an extended downwind leg of such length that it will require some power greater than idle thrust during the descending final approach to the runway. The longer approach allows more time for precise and stable control throughout the landing approach.

The recommended indicated-airspeed on the final approach descent will approximate 1.3 times the stall indicated-airspeed of the airplane in landing flap configuration ($1.3 V_{SO}$).

You should be able to demonstrate, and be proficient, in making approaches at various descent angles of approach.

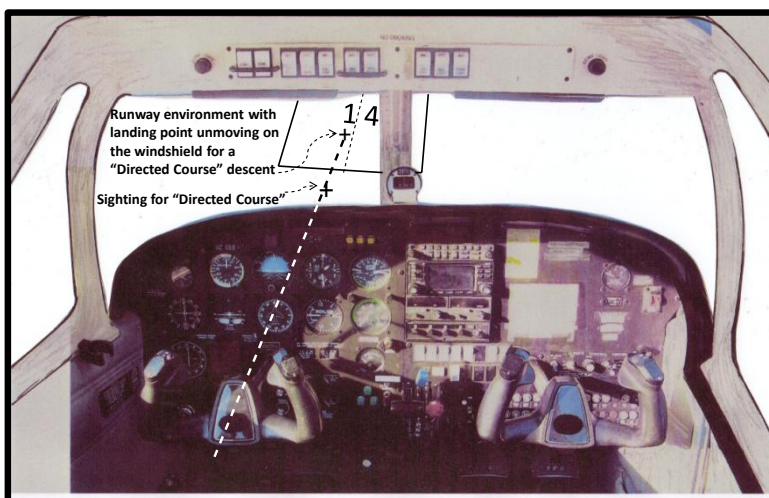

“DIRECTED COURSE” VISUAL REFERENCE FLIGHT

Landing Approach, Wings Level Flight

Fig. 3-6

Early configuration and stabilization of indicated-airspeed are primary. A normal partial-powered visual approach rate of descent will be approximately 300-600 ft/min. The usual sight picture for landing approaches places the landing point centered toward the bottom of the windshield.

Approach descent pitch angle can be adjusted by changing the fixed visual picture up or down on the windshield. The steeper the descent angle desired, the lower the landing point, sighted on or below the windshield.

Flying a Directed-Course (collision course) will maintain the landing-point sight-picture, in a constant position. Once the landing area is

orientated nonmoving on the lower windshield, you control the airplane with small power changes for vertical control and aileron/rudder steering for directional control to fly to that point.

Prior configuration and trimmed indicated-airspeed (elevator-pitch) will remain almost constant. Vertical control will be with minor power adjustment and heading input (with rudder/aileron) for maintaining this desired sight picture.

On short final approach, begin aircraft steering control with the rudder. The rudder is primary for main wheel (longitudinal) alignment in the direction of motion. Side slipping with opposite aileron turning will provide side-to-side tracking correction as necessary to compensate for any crosswind drifting and maintain tracking of the centerline of the runway.

Roundout Attitude

When approaching the landing area, just above the ground, you will begin (back/to/pull) manual elevator input, gradually leveling (roundout) to slow the indicated-airspeed while decreasing the descent rate. The attitude becomes similar to the cruise attitude sight-picture on the windshield.

You accomplish this by steadily increasing the angular attitude (manually raising the nose with aft elevator-pitch control) as approaching approximately ten to fifteen feet above the ground. At the same time, you gradually decrease power toward idle throughout the landing roundout flare.

Flare Attitude

The flare is a continuation of aft elevator-pitch control beyond the roundout level attitude. It causes continued slowing of indicated-airspeed and reduction of the sink rate. The attitude becomes slightly nose up with coordination of continued aft elevator-pitch input. Your sight picture will approximate the lift-off attitude with the nose being near or just below the horizon.

As you approach touchdown, the surface alongside the runway, sighted peripherally, begins rising toward you along the sides of the aircraft, becoming similar to the visual picture seen during takeoff. You will steer with the rudder while sighting down the runway centerline, and adjusting descent from the peripheral sighted visual sensing along the forward sides of the runway.

The objective is to descend at a minimum descent rate with reduced forward groundspeed, coordinating descent with small power adjustment. When performed correctly, while holding a slight nose high attitude, controlling a minimum descent rate and the indicated-airspeed approaching the stall indicated-airspeed your airplane main wheels will gently contact the ground with power at or near idle.

The stall angle-of-attack is probably 15 degrees or more, so you can expect touchdown near that nose-up attitude.

Landing/Ground Roll

At touchdown, control of your decelerating airplane is to track the center of the runway, using rudder steering for directional control, and with the ailerons continued as required until turned fully into any wind. The slowing after touchdown will allow nose-wheel ground contact for surface friction steering.

The aircraft is now in a high-speed taxi. Your sight picture has returned to the taxi picture. Initiate additional deceleration and directional control with braking, as necessary.

With forward sighting of the runway centerline for guidance, and directional control maintained with rudders and brakes until stopped, this completes the flight.

Collision Course

A collision course is a course or path of travel that, if unchanged, will lead to a collision with another aircraft or object. That means two airplanes are flying courses that will cause them to arrive at the same time at some point ahead. Obviously, they will collide if they arrive at the same time over the same point at the same altitude. These kinds of courses can occur from any direction, horizontal or vertical and at any airspeed. It is all a matter of coincidental or purposeful positioning.

A collision course is sighting of another object that does not move relative to a point on your window and usually is an inadvertent course discovered when sighting other traffic in flight. Any relative movement across the window would indicate the sighted object is going ahead, behind, above or below depending on its direction of movement.

Sighting another airplane in the vicinity of one's own airplane and flying a course that the other airplane does not move on the window will eventually cause the airplanes to meet/collide if there is no evasive maneuvering. In this situation, the pilot must maneuver the aircraft in a manner to cause the sighted traffic to move on the window thereby breaking the collision course.

Moving sighted traffic on the window merely requires maneuvering in some manner. Most training refers to turning toward or away from other traffic. In an emergency, rapid zooming up or down is the quickest and most efficient way to move the sighted object across the window.

There is no right-of-way consideration when in flight. Though there are specific rules regarding airborne traffic right-of-way, without some sort of confirmation the other aircraft sees you and is planning a specific maneuver one can only assume they don't see you and you must maneuver in whatever way is appropriate to maintain clearance.

The most important aspect of a collision course is how to recognize, initiate, break, utilize, or avoid them. When flying an aircraft, anytime sighting any other aircraft or object that does not move relative to a point on the window, if continued, you will eventually collide with that particular machine or object.

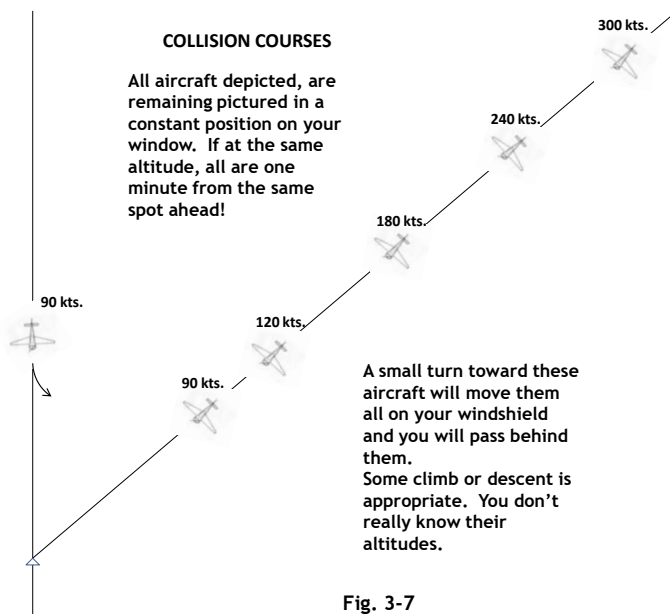



Fig. 3-7

Course correction when sighting an aircraft on a possible collision course is to immediately climb or descend simultaneously turning toward or away enough to assure the targeted aircraft moves relative to the reference point on the windshield or window. Turning toward the subject aircraft will allow keeping it in sight. Turning away may put your aircraft belly to it and possible loss of sight. Practice and consideration of different scenarios will help prepare for making the proper decision when it occurs.

It is usual to have occasional close encounters with other aircraft. It is not usual to have encounters requiring emergency maneuvering, but they do happen. It is your responsibility to react correctly.

Close counts. Just don't touch. 



Chapter 4-----VISUAL APPROACH AND GO-AROUND

Whether in a visual traffic pattern or an instrument approach, the short final approach and landing are always visually controlled. This chapter discusses the procedures for visually attaining and maintaining stabilized descent and approach for landing and the procedures necessary for continuing the landing or abandoning an approach if necessary.

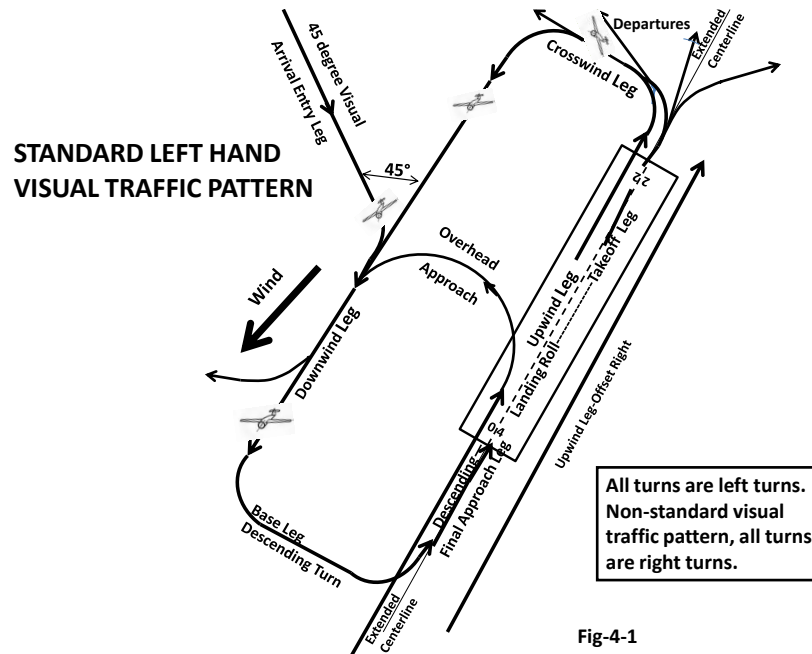

Descent Maneuvering

Decreasing power from the level, constant indicated-airspeed condition decreases the thrust component-lift contributing to angle-of-attack slightly, allowing some acceleration.

This becomes a different control situation. Any power change in descent will now affect the angle-of-attack. Constant indicated-airspeed descending flight requires coordinated elevator-pitch change with every power change.

The airplane begins descending allowing the addition of gravity component-thrust for sustaining the aircraft aerodynamic lift at a new indicated-airspeed. To reduce back to the original indicated-airspeed,

it is necessary to coordinate elevator nose-up pitch. With that, the stabilized aircraft in descent maintains the desired indicated-air speed.

When operating in descent, an increase of power will increase the thrust component-lift as usual, but now this pitch change will first increase the angle-of-attack until slowing to the associated level flight indicated-air speed called for with the combination of current elevator-pitch and the increased thrust component lifting. When it decelerates to the level flight indicated-air speed for this newly trimmed condition, any additional thrust becomes excess thrust and will cause climb at this new slower indicated-air speed.

We previously added nose-up elevator-pitch when initiating the descent and now adding power increases the thrust-component of pitch causing a new and greater angle-of-attack allowing a slower indicated-air speed.

The condition of elevator trimmed slow indicated-air speed during descending flight dramatically changes with large increases of power. Without coordinated reduction of elevator-pitch while adding large power increase in descent, it is possible to cause inadvertent high angles of attack. This is commonly a contributing factor to the occurrence of low altitude, low indicated-air speed stall.

Slow indicated-air speed maneuvering with descending turns is a continuation of these same effects from power change and its effect on the angle-of-attack. There is always this same response for any power change in descent whether wings level or turning.

If very slow, the increased power can cause approaching stall without pulling the control wheel...always coordinate reduced elevator pitch control with power increase when at a slow indicated-air speed.

The high angle-of-attack with slowed indicated-air speed requires care if inputting any aft elevator control. There is a changed visual presentation when maneuvering in turns. A high angle-of-attack is obvious when the wings are level, however, in a descending turn; the pitched attitude visually appears much lower. The attitude of the aircraft with reference to the horizon becomes misleading.

In actuality, the nose is lower relative the horizon and can even be below the horizon in a descending turn. This condition of visual awareness becomes hidden more and more as bank angle increases. A pilot must be consciously aware and consider these attitudes when controlling in steep banked descending turns. Only with pilot awareness, and understanding of this situation, can there be safe control.

Approach Maneuvering Slow Flight

Slow indicated-air speed maneuvering with descending turns continues the effects of power change to the angle-of-attack. There is always this

same response for any power change in descent whether wings level or turning.

All slow flight has an angled nose-up attitude in the direction of motion. In the steep banked descending turn, the angled motion is toward the surface, so visual reference of pitch angle is very different from the usual sighting expected with wings level flight.

In a turn, it is almost impossible to see any reference of the nose attitude pitched high and the related motion as being slow. The turning maneuver must be a learned attitude with drilled understanding of the response to be expected. Quite simply, always be ready to reduce pitch (push the control wheel), reduce bank angle, and then add power throughout any steep turn.

This type maneuvering requires cautious use of aft elevator-pitch input. Slow indicated-airspeed means there is little allowance for increased angle-of-attack before approaching wing critical angle-of-attack and stall. A pilot must understand low altitude slow indicated-airspeed maneuvering has definite limitations. This means pushing the control wheel for angle-of-attack coordination with any increased power input.

Base Leg to Final Approach

The standard rectangular visual traffic pattern requires a descending banked attitude for the two 90 degree turns from downwind leg, to base leg onto the final approach leg.

Approaching the extended runway centerline from the base leg, adjust the final approach turn toward the landing runway. Control the descent to be over the extended centerline on a Directed-Course with the landing area, unmoving on the windshield.

If low when flying inbound on initial final approach, reduce the descent rate with added power until the landing point moves down on the windshield. Retarding some power again increases descent rate to maintain the touchdown point sighted unmoving the windshield.

Initiating descent to maintain the landing point sighted unmoving on the lower windshield creates approximately the same approach angle for all approaches.

With final flaps selected, indicated-airspeed adjusted to 1.3 V_{so}, and with the landing checklist completed, the approach continues.

Base Leg to Final Turn Overshoot

The base leg to final approach turn has a history of inadvertent stalls. This turn is the time a pilot is attempting to direct the aircraft toward the runway end while aligning over the extended runway centerline. Attaining appropriate alignment requires previous positioning on the downwind leg to allow sufficient space for visually controlling the

ground track of the descending base leg and final approach turns to roll out on the extended centerline of the landing runway.

Conditions causing misalignment of the final turn are common, and often the result of improper initial downwind positioning for the turn.

If flying the downwind leg too close to the runway there is not sufficient distance for the turning ground track.

A strong crosswind on downwind can cause the aircraft to be drifted toward or away from the runway. Continued drifting, when flying the base leg and the base to final turn, also can lead to an overshooting condition.

Any condition of wind or maneuvering misjudgment can create the situation of overshooting or undershooting the final approach tracking.

When overshoot becomes obvious, a pilot must always consider a go-around. If it requires more than 20 degrees bank to re-align to the extended centerline, it likely requires a go-around.

There is a strong tendency to attempt holding a fixed steep bank angle and attempt to increase the turn rate with rudder. This easily becomes an in-advertent cross-control situation.

At the same time, in this banked attitude the pilot may pull the nose up with aft elevator-pitch input as an attempt to increase the rate of turn.

The aircraft would now be in a steep cross-controlled turn, and at the same time, the indicated-airspeed decreasing due to back elevator-pitch input. All this added aft elevator input will simultaneously increase “g” loading, causing an increased stall indicated-airspeed.

Controlling the descent rate with back elevator-pitch input, and continuing this steep banked condition it can quickly cause inadvertent low altitude stall. Additionally, if holding aft elevator or trimming the elevator to very low indicated-airspeed, adding thrust causes increased pitch and may cause immediate stall.

It is interesting to be aware that pulling the elevator control or added thrust and especially both together can cause the aircraft to stall.

During all this time, an unaware pilot’s attention fixated on attaining the landing approach positioning while attempting to direct the aircraft to the landing area can inadvertently cause stall.

The slower indicated-airspeeds used during approaches reduces control input resistance and feel, and a steep bank angle does not have the appearance of a nose-high attitude. The reduced control feel and visual sensing may not alarm the pilot while concentrating on correcting the aircraft tracking.

This awareness of visual attitude becomes hidden more and more as bank angle increases. A pilot must consciously know and consider these attitudes when controlling in steep banked descending turns. Only with pilot awareness, and understanding of this situation, can there be safe low indicated-airspeed control.

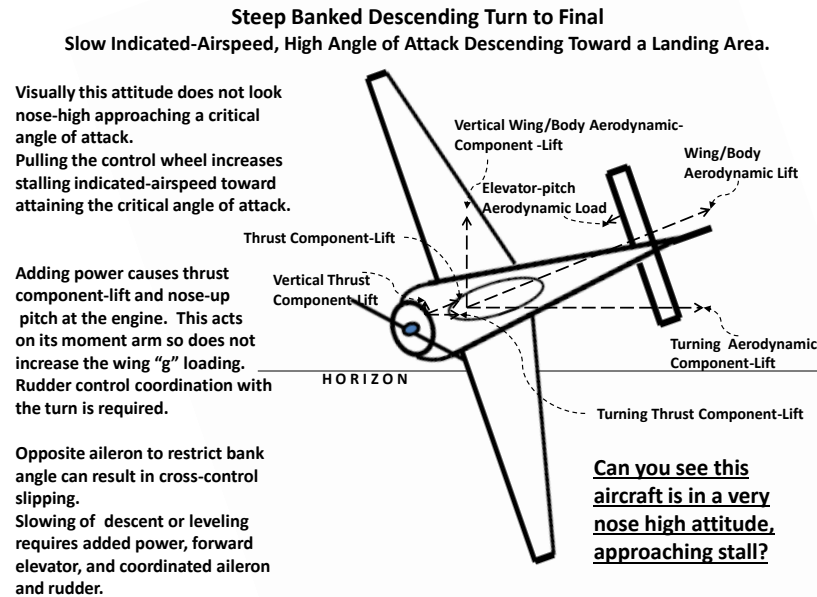

Fig. 4-2

Adding to the confusion can be a common mental attitude of pilots that when the runway is in sight, nothing interferes with the landing. The go-around is the last thing likely to come to mind...even if briefed before the approach.

The pilot is flying without conscious awareness of control input. Wrong positioning and an assumed importance of needing to "make" the runway to land have distracted the pilot while continuing unusual or even extreme control. Any number of distractions could exist. Fly your airplane first! A landing from every approach is not required. If you can't afford a go-around, you can't afford flying.

An understanding of control during these kinds of maneuvers needs to be firmly entrenched during pilot training. Increasing the turn rate with the descending steep turn must be with some increased engine thrust component-lift by adding power before or instead of adding aft elevator.

In the steep turn, if power is applied, the engine-lifting force is primarily pulling the turn by lifting the nose along its fuselage moment arm instead of increased aerodynamic loading of the wings.

It will still require forward (nose-down pitch) elevator control to allow continued safe indicated-airspeed in the steep turn with the increased power because when in descent the increased power adds back a certain amount of pitch to the angle-of-attack.

This is a condition where energy management zoom/dive steep turn technique may be appropriate or required.

Remember that power at slower indicated-airspeeds has the direction of thrust angled slightly upward from the direction of motion. A $V_{1.3so}$ approach will be with at least a sustained 6 to 8 degrees nose-up attitude from the direction of motion.

In addition, when operating at lower power settings added power causes thrust component-lift with nose-up pitch. Being in descent, some of this initial pitching from added power will increase angle-of-attack.

Without opposite elevator input, it allows even slower indicated-airspeed until reaching the new level flight sustaining thrust called for from both any previously added elevator-pitch trim and this increased engine-pitch.

If continued, this condition stabilizes at a slower indicated-airspeed. If not changing elevator-pitch, the aircraft will merely slow to the reduced indicated-airspeed as set with a nose-high attitude and slower flight.

Visual Approach

Whether a flight is in visual, or instrument conditions, it requires visual contact for every approach from short final to landing touchdown, so understanding the sight picture and being aware of visual references, is significant.

Power adjustment and flight control input maneuvers the aircraft to a directed-course for the selected landing area at the runway approach end, centered and unmoving on the windshield.

If not attaining proper stabilization for normal flight, you can always abort the approach with go-around procedures.

At, or before, establishment on the visual downwind leg, complete the landing briefing and checklists to the final landing flap setting. Make adjustment of the downwind and base leg, closer or further from the runway, as necessary for the approach and crosswind conditions encountered. Most small aircraft fly the downwind leg from ½ to 1 mile away from the landing runway.

A standard approach pattern extends the downwind leg, 20-30 seconds, flying beyond the runway end, before turning onto the base leg. Extending the pattern allows reduced descent rates and requires using partial power when maneuvering throughout the approach. This results

in more stable and positive control for an approach with added time and space for correcting possible ground tracking error during the final turn for the approach extended centerline alignment.

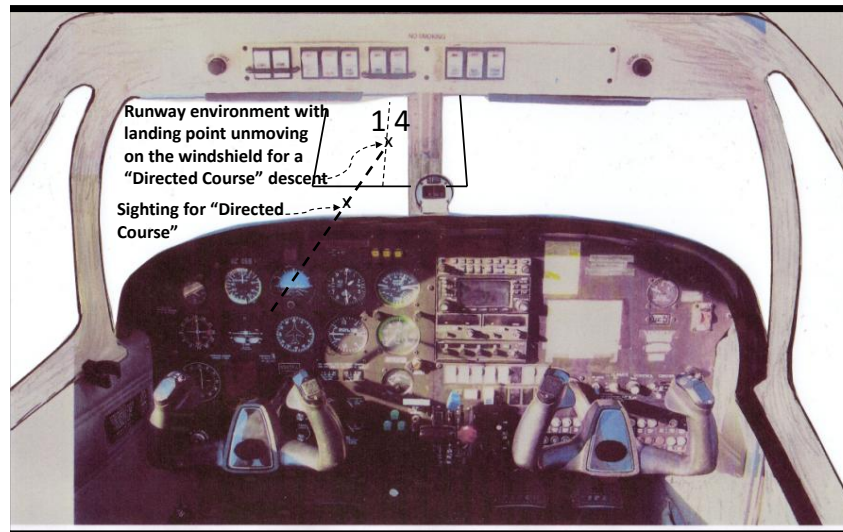

“DIRECTED COURSE” VISUAL REFERENCE FLIGHT
Landing Approach, Wings Level Flight

Fig. 4-3

An idle-power approach begins with a descending base turn within 10-15 seconds after passing the runway approach end, with a continuous descending turn and descent rates as much as 700-800 feet per minute. The descent and turning procedures are the same. Power remains available for correcting if getting too low.

The Normal Approach

It should be the intent for all final approach and landing procedures to be as similar as reasonably possible. All approaches to landings are essentially the same. On any approach, from the moment sighting the runway, the Directed-Course procedure allows visually controlling the flight to the selected landing area with similar sight pictures every time.

Final approaches operate at a target indicated-airspeed required for weight and wind conditions and with descent rates to maintain an instrument glideslope or visual approach angle.

With wings level and the aircraft aligned over the extended centerline, the visual placement of the landing area in the same general position relative to the windshield makes all approach descent angles appear similar. The sight picture of the aiming point remains unmoving on the stabilized approach.

This technique is especially helpful at night with either power on or idle approaches. Maintain a safe flight altitude while flying toward the airport until the sighted landing area is near the bottom of the windshield. This will avoid descending too early if approaching over obstacles or unfamiliar terrain.

If the sighted landing area moves down, relative to the point on the windshield, reduce power to increase descent angle. If the landing area moves up, relative to the point on the windshield, increase power to reduce descent angle.

If very high on approach, do not push the elevator causing increased indicated-airspeed, but immediately reduce power and add configuration drag or forward slipping to decrease indicated-airspeed and attain increased descent rate back to the desired visual sighting. Then resume normal approach indicated-airspeed and configuration.

Small indicated-airspeed changes can occur with small power changes. If stabilized on the approach, these changes will require little elevator input to continue.

Directional steering control on approach short final is with rudder input coordinated with aileron input. Rudder steering for main wheel alignment in the direction of motion at touchdown and aileron turning into any crosswind controls side-to-side alignment with the centerline.

A successful landing should result from a stabilized approach toward the selected point.

Idle-Power Approach

The concept of making approaches and landings at idle power evolved in the beginning of flight. Unreliable engines required initiating idle-power approaches within gliding distance of the airport so allowed gliding to the touchdown area. This resulted in steeper descent and steeper banked approach procedures often considered the cause leading to steep-turn stall incidents.

Improved engine reliability led to the procedure of extending the landing approach as a safer method. Remaining within gliding distance of the airport no longer is considered as important as attaining stabilized engine powered visual approaches.

The extent of this thinking led to the unintended consequence of eliminating the requirement to attain proficiency in the idle-power approaches and landings during initial training. The idle-power landing procedure became a commercial pilot maneuver, demonstrated after attaining advanced flight proficiency.

Idle-power glide approaches are to teach the pilot steep approaches with appropriate use of flap and forward slip as drag for descent control. These procedures are similar to, and require the maneuvering

proficiency required for emergency power-out landing approaches. It still must be a pilot's personal requirement to be proficient in these approaches and landings.

In reality, though not a required maneuver for the private pilot, the lessons learned in doing the engine power-idle approach are just as valid as they have ever been. The beginning pilot initially learning flight track, planning, judgment, and control in this manner is then proficient in both, the normal and emergency approach and landing.

It is necessary to establish a visual directed-course on any approach. This allows judgment that is more precise and gives more time for descent rate and ground tracking adjustments.

There must be an understanding that all approaches whether with or without power should essentially be the same. It is the recognition and practice of learning how to direct the machine performance. Every approach is controlling to a chosen landing area on the runway.

When established on a Directed-Course, more accurate control of the flight path, approach indicated-air speed and glide angle is possible. The control necessary to make that happen is always the same.

Idle-power approaches require ground track and descent angle control with aircraft maneuvering and drag from attitude and configuration change.

Judging when to turn to the final approach determines attaining the idle-power approach tracking. Adjust undershooting or overshooting by altering the beginning of the turn toward final approach. "S" turns may be possible when aligned straight in on the final approach though they are not too effective unless used early on the approach.

The use of flap extension changes, small pitch adjustments, and forward slip can control the descent rate with idle-power.

Lowering the elevator-pitch attitude in an idle-power approach that is too high increases indicated-air speed, possibly forcing the airplane to float past the desired touchdown point. When at or below best glide indicated-air speed, raising the elevator-pitch attitude in a "too low" idle-power approach, in an attempt to increase the glide distance, will cause the airplane to sink more rapidly, due to a lowered indicated-air speed, while simultaneously approaching closer to a stalling situation.

If using full flaps during an idle-power approach and it becomes apparent undershooting is occurring, depending on the aircraft, it may be necessary to retract some of the fully extended flaps to reduce drag. This requires knowing the required indicated-air speeds with partial flaps and full flaps, and if those indicated-air speeds are appropriate at the time.

All prolonged operations at idle power require clearing the engine periodically, by momentary increase of the rpm to avoid possible loss of power.

Though idle-power approaches are good practice for simulated engine-out procedures, the engine power is still available for correcting the approach if necessary.

It is appropriate, for a pilot be proficient in idle-power approaches, before the first solo.

Straight-in Idle-Power Approaches

When established straight in on a power-off or idle-power approach, maintaining a visual Directed-Course is primary for control.

Sight the landing area, unmoving, low in the middle of the windshield. As the flight progresses, if at best glide indicated-airspeed, the aircraft cannot reach the landing area if the selected area moves up on the windshield. If the landing area moves down on the windshield, the aircraft will overshoot. Only when the landing area remains unmoving in the same position sighted through the window will the aircraft attain the chosen landing area.

This is how to recognize a “Directed-Course” (collision course) to a landing area. Use this procedure for establishing the flight path of the airplane for all approaches, especially when flying any gliding approach with power-off.

The power will remain in the idle position during this approach. Change of glide angle will occur with drag from changes of flap settings or slips. On initial approach, fly engine out or idle-power approach indicated-airspeed, based on the best glide indicated-airspeed, for a current configuration.

When established on the final approach, there then must be a decision to fly above or below the best glide indicated-airspeed. If below best glide, this makes it possible to extend the glide by pushing down to return to best glide. Consider slowing 10-15 knots toward maximum endurance (V_{me}), as a final approach indicated-airspeed.

Pitching down from indicated-airspeed slower than best glide indicated-airspeed enables an increase to the best glide indicated-airspeed, which again extends the glide distance. Continuing descent into ground-effect can also extend the glide even further.

Retraction of a portion of the flap extension reduces drag on most aircraft. Pilot initial checkout must include the effect of flap extension when gliding at the different extended positions.

Pitching up if faster than best glide indicated-airspeed, corrects an excessively low approach. The indicated-airspeed decreases toward the best glide indicated-airspeed, extending the gliding range.

Crosswind Landing Approach

With stronger crosswinds, you should always consider the go-around in your approach planning in the event initial alignment from the base turn is not satisfactory, or a stabilized approach not attained.

The aircraft, angled (crabbed) into the wind for maintaining the final approach course tracking causes offset of the landing sight-picture. The normal unmoving targeted picture will now be toward one side of the windshield.

On short final approach, align the airplane with the center of the runway with sideslip. Initiate application of slipping control by individual technique. The result of the approach at touchdown requires having applied a slip prior to touchdown assuring longitudinal axis (main wheel) alignment paralleling the centerline of the runway, in the direction of airplane motion.

Side slipping the aircraft is aligning the longitudinal axis to the direction of movement by steering with rudder. The sight picture will then have the landing area again centered on the windshield. This will be a banked attitude into the real wind creating a horizontal force to neutralize the crosswind component-force.

For some pilots, the initiation of the slip maneuver begins early on the approach assuring there is sufficient rudder control and time enough to establish a stabilized slipping attitude to continue the approach.

Often, crosswinds close to the surface change as the aircraft descends. With experience, a pilot may continue the crabbing approach, then prior to touchdown, during roundout, flare, or even just at touchdown, enter the slipping maneuver in one coordinated maneuver, steering with rudder to align the wheels with the direction of the runway, and applying opposite aileron as necessary to maintain tracking of the centerline.

Either way of making the approach, cross-control at touchdown must be with steering the rudder to align the aircraft to the direction of the tracking motion, and a banked attitude turning force to offset the crosswind force, allowing main wheel touchdown without skidding sideways.

In high-crosswind conditions where rudder authority may be marginal, maintain the approach crab until just prior to touchdown. Many aircraft control better with partial flaps in crosswinds.

With landing assured at the desired landing area, partial power-on as required will allow propeller-blast to help maintain rudder authority during the touchdown and landing roll. In stronger winds, it may be necessary to maintain propeller-blast throughout the landing roll, even while braking and taxiing. In an extreme, up to maximum power could be used during the landing roll.

Approach Over an Obstacle

Extend the downwind sufficiently to enable establishing a final approach, tracking directly toward the runway. The procedures are the same as any approach. Fly a stabilized approach with the final landing configuration selected, and the final checklist completed.

Begin the approach descent with the runway visually sighted near the bottom of the windshield. If the obstacle appears within that sighting, add power to reduce the descent rate. Continue controlling to attain a sight picture (Directed-Course) of the obstacle positioned near the bottom of the windshield.

Fly at normal approach configuration and indicated-air speed, as if using the top of the obstacle as the aiming point. This will assure passing at a minimum distance for clearing the obstacle.

After passing the obstacle, maintain the configuration and adjust power and/or slip for increased descent rate as necessary to maintain the landing area sighted unmoving on the windshield.

Ground-Effect

When in very low-level flight, the surface restricts the air mass displacement below the wings restricting the downwash under the back of the wing so reduces drag. Every takeoff and landing experiences ground-effect while within a few feet of the ground.

The restricted displacement of air mass below the aircraft is greatest when near the surface, gradually disappearing with increased altitude until eliminated at an altitude of approximately one wing length. The wing length of most small aircraft is less than 20-30 feet.

During takeoff, early lift-off at a lower indicated-air speed eliminates ground friction and by staying very low allows use of ground-effect for faster acceleration to a safe indicated-air speed before beginning climb maneuvering.

When landing, ground-effect is useful for extending glide distance. As a technique, if a power-off approach appears to be short, then deliberate descent, even with some increased indicated-air speed, to within a few feet of the ground, allows the use of ground-effect to extend glide distance.

It is difficult for a pilot, to want to pitch down when very low to the ground on an approach. There should be previous demonstration, teaching, and experience controlling and operating at such low altitudes.

Training to fly the aircraft low to the ground when over an unprepared landing area, being close to the rocks and trees, can be an unnerving experience if one is not familiar, yet this tactic is very useful in an emergency landing.

There is considerable difference between the ground-effect with high-wing versus low-wing aircraft. Awareness and use of techniques for idle-power glide control proficiency using ground-effect will only come with practice and drill.

Practice using ground-effect should be part of an aircraft checkout. The new pilot should become well versed in these techniques from the first flight.

The Go-Around

Going Around, Aborted Landing, Missed Approach, and Landing Overshoot are terms to indicate abandoning the landing and a go-around procedure initiated.

Any time not satisfied with the approach or runway condition, initiate the abort. This is seldom an emergency procedure. Any one of many situations or events may require initiation of the abort procedure.

Preparing for Go-Around

A problem, normally not considered with go-around procedures, is the human element involved. It is seldom a pilot has in mind the possibility of a go-around when initiating a visual approach. Even with marginal conditions, there is often no prior consideration of aborting the approach.

The events involved in unexpected go-arounds require rapid change of mind-set and are not often experienced. For that reason, it is useful to consider the possibility and even add it as a consideration to approach descent checklists and briefings.

Initiating a Go-Around

The actual go-around requires stopping descent and transitioning to acceleration, climb power, and configuration change toward a normal takeoff procedure.

What happens when interrupting a slow indicated-airspeed, descending approach with rapid application of go-around power?

This is a common experience in the landing configured go-around scenario. Maybe it is not necessary to cram all that power in so fast.

What is the status of the aircraft in go-around mode? Some nose down elevator-trim input is normal for allowing acceleration while at the same time initiating pitch up to stop the descent. These two actions can easily conflict in one's mind if not previously considered.

If in instrument conditions, stopping descent becomes more of a priority. The main objective, whether in instrument or visual conditions, is to stop descent and maintain at least level or some climb.

What does it take? Is there a big hurry to get things done? It simply requires normal after takeoff considerations. After all, you are already flying. The procedure is putting the aircraft into a powered takeoff configuration. As with all flight, the pilot needs to be acquainted with the possible situations, and the different considerations.

Go-Around Situation

So, what happened when initiating a go-around? You are in a lower powered, low indicated-airspeed, descending mode with extra drag from the extended flaps. Initiating the “go” is with increased power and stopping descent.

The aircraft will immediately increase climb pitch and with a large power increase causing significant nose pitch-up.

Adding power increases lift at the engine and allows deceleration due to this engine thrust component-lift effect and possible propeller-blast on the elevator.

At the same time, the tendency to pull the elevator for stopping descent may add elevator-pitch up. That is telling the aircraft to slow.

The fact remains the go-around should be a simple procedure. With increased power, stopping descent, allowing acceleration, and elevator trimming of a desired climb indicated-airspeed. The pitch control will then be back to a level, sustained thrust for an indicated-airspeed plus excess thrust for climb. Normal flight continues while readjusting the indicated-airspeeds with any configuration change.

The objective is to attain a takeoff climb indicated-airspeed and configuration for the continued flight.

Go-Around Procedure

After leveling, or starting positive climb, with acceleration, consider the required configuration changes. Going back to a normal VFR downwind, consider retaining partial flap configuration. A visual go-around always requires a climb to downwind altitude.

Why retract the gear, if it is down and safe, leave it alone. Just fly a normal airplane and another traffic pattern for the next approach.

A visual go-around is not the same as when initiating a missed approach instrument procedure, or an emergency, such as in multiengine, engine out go-around procedures. Again, use the same considerations as for any normal takeoff.

The problem is to have an understanding of what the situation requires. If the pilot has practiced various scenarios that could occur, these kinds of decisions become apparent.

Why did you initiate the go-around? What caused the problem and where am I going next? Is it a missed approach with a following

instrument procedure or a return to a standard downwind? Is there a problem with the aircraft or are things normal and just a continuation of the flight because of something that occurred at the runway?

Aborting a landing is a go-around or missed approach. It is a procedure. It not only requires aircraft controlling but also planning where to go. There is transitioning from a descending low power, high-drag configuration, to high-power, level or climbing acceleration, clean configuration.

The go-around or missed approach continues with normal takeoff flight indicated-airspeed and climb back into the traffic pattern.

Add power, stop any descent, and start nose down/away elevator-pitch as necessary to allow acceleration. The power application will probably do that but in any case find the takeoff visual picture of the horizon low across the window and a point toward which to fly.

When attaining positive climb, begin slow retraction of the flaps, while monitoring the indicated-airspeed for each setting. Assure the aircraft is level, or climbing, while trimming to a V_y indicated-airspeed and completing retraction of the flaps.

If going back to the visual traffic pattern, from the upwind leg, continue climbing straight ahead, as a normal takeoff, to the field boundary, before turning onto the crosswind leg.

If the cause of the go-around is another airplane taking off, turn away from the pattern to offset and track parallel to the runway, so the conflicting traffic is visible, and cannot climb into you.

At a towered airport, the controller would probably provide further instructions if there continued to be a conflict. No matter what is going on or what the controller may say, clear visually for conflict with any other airplane before turning across its path. Again, whatever it may take, even to the extent of turning away out of traffic and climbing up and around for another 45 degree entry.

When clear of conflict, turn to the crosswind and downwind pattern legs while climbing to traffic pattern altitude and continue normal procedures. This type conflict is common, and like all things, could happen today.

When to Go-Around

The most usual situation, requiring a go-around, is the base turn to final where the pilot misjudges the turn and overshoots the final approach. Final turns that pass too far beyond the extended centerline for safely maneuvering back, or are too close and high to the touchdown area require aborting the approach.

You must understand when it is appropriate to make a go-around. In most ways, it is quite clear. If not lined up with the runway when

turning onto the short final approach, it is probably prudent to consider a go-around. If not stabilized at the approach indicated-airspeed, or properly configured, initiate the go-around.

If the landing is not going to be within the selected touchdown area, it probably requires a go-around. This situation causes most landing incidents and accidents when, for some reason, pilots think they just have to land. Wanting to make a schedule is no reason to land long and run off the far end.

There are too many incidents of the decision to land when touchdown is long or fast. If not on a stabilized approach to allow touchdown in the desired area, it may be necessary to make a go-around. Without prior consideration, the length of remaining runway for rollout can become much too short. If your employers hassle you about go-arounds, they can't afford to operate aircraft.

Go-Around at or After Touchdown

Approach briefings should consider the possibility of go-around. There can be unusual situations occur that require aborting the landing even to touchdown and rollout.

Anytime, during the roundout, flare, or touchdown, if control becomes marginal, just go-around. A go-around may be possible, even early in the landing roll after touchdown, when still at higher indicated-airspeed.

Consider the remaining length of the runway and any possible obstacles before making the decision for after touchdown go-arounds.

It is often possible to resolve control problems during rollout by momentary added power. Resulting propeller-blast airflow on the tail and accelerated indicated-airspeed can regain control, go-around! It is much easier to do it right the second time.

Trying to land when control is uncertain is not worth it. It is too easy to lose that control and end up damaging the airplane.

The Mindset

There is a pilot ego thing when making a landing. Most pilots have a mindset wanting to continue even when things are obviously going bad. Someone landed before, so the pilot following assumes it is possible.

The conditions may change, or the pilot ahead may be more proficient. No one ever knows. Pilots must fly their own aircraft based on its performance and not that of someone ahead or behind.

It is a mistaken belief that it looks unprofessional to make a go-around. Real pilots understand the necessity of go-arounds, and understand what is taking place. 

Chapter 5-----TAKEOFFS

Beginning a flight requires preparation and planning. Once in the aircraft, flight is operating a machine...but it's a big machine. On the ground, think of where the wingtips travel and the blasting air blows.

Takeoff is steering down the centerline of the runway at a high thrust setting, accelerating until the machine begins to fly. It will fly by itself; its design is to do just that. Control is steering, pointing it in the direction you want to go.

Taxi

You start the engine and prepare to taxi. This is driving the aircraft on the surface. Acceleration is with the hand throttle, steering is pushing the rudder pedals, and stopping is with the individual foot operated brakes on the rudder pedals.

Students often need demonstration of the technique of “wiggling” the rudders to and fro for precise directional control until learning the “feel” of steering with the feet. Find an excellent explanation of manual control input in Appendix 1.

While maneuvering on the ground there also needs to be consideration of the effect of “blasting-air” from the propeller and the tracking of the wingtips.

There are pre-takeoff procedures to assure proper configuration of the aircraft and that the engine and flight instruments are functioning properly.

For initial flight control, there is a pre-takeoff setting for the elevator trim. This setting determines the indicated-airspeed at which the aircraft will begin to fly. For reference to flight in this text, we set the elevator trim to a required initial indicated-airspeed to cause liftoff.

Normal Takeoff

You taxi onto the runway for takeoff. With most small aircraft, it is brake release and takeoff power set to maximum forward throttle. The aircraft begins accelerating down the runway. You control alignment along the centerline of the runway with rudder steering.

As the velocity increases, the increase of relative-wind allows response to the flight controls to become effective. Engine torque, propeller p-factor, gyroscopic precession, spiraling slipstream are left turning effects at the high power setting requiring positive rudder steering for maintaining heading. As the aircraft transits the indicated-airspeed set by elevator-trim or earlier with added aft input of the control wheel, the aircraft lifts off. It is now airborne.

Continue steering with rudder input, aided with coordinated aileron control turning as may be required. Visually sighting a point on or toward the horizon allows maintaining direction as you continue ahead in a slight nose-up climb attitude. You are at the lift-off indicated-airspeed. You are in space with three-dimensional maneuvering possible.

Since setting takeoff power, there has been minimum pilot flight control input, just steering with rudder and some slight turning with aileron. As the aircraft transits the indicated-airspeed set by elevator-trim and the aircraft begins flying, if needed, ease the control wheel forward to attain minimum climb with level flight in ground-effect allowing acceleration to the desired climb indicated-airspeed.

Crosswind Takeoff

Taxi and takeoff when crosswind exists requires consideration of wind effect. A Pilot must always be aware of the current wind direction and velocity prior to starting the takeoff roll. A quick mental calculation (.5, .7, .9) will estimate the crosswind component for takeoff. In all cases, visual control of takeoff tracking is by using whatever control input it takes to maintain centerline tracking.

Taxi maneuvering requires continuous consideration of wind effect when changing direction of motion. The aircraft's large aft body area will cause weathervaning and the large upwind wing area allows the wind to attempt lifting with tipping of the aircraft.

Power increase for blasting air from the propeller aids rudder control for steering and the ailerons turned into the wind reduce possible lifting of the upwind wing.

Takeoff will use normal procedures with rudder for steering and the ailerons turned fully into the wind to prevent gust lifting. As the relative wind increases during acceleration, the effect of control inputs increase so aileron gradually reduced will be almost neutral when becoming airborne. Whatever it takes!

At liftoff, the aircraft will tend to weathervane toward the wind effect so rudder steering should be used for runway alignment for a few seconds in event of touchdown shortly after liftoff.

When positively airborne, the weathervaning will cause visual centerline tracking to move to a point away from straight ahead. You will see you are traveling slightly sideways over the ground.

In gusty wind conditions, continuing flight should be with positive climb to prevent any inadvertent touchdown in the crabbed attitude.

Short-Field Takeoff

For short-field takeoff, configure the aircraft in its most efficient climb (V_x) indicated-airspeed and configuration. Some aircraft will use a minimum flap setting. This is determined from the aircraft POH or from prior flight test.

Use the maximum available runway length and maximum power. Approaching takeoff indicated-airspeed, add some aft elevator control to cause liftoff and maintain a low, level, attitude for acceleration in ground-effect. Continue as necessary even beyond the remaining runway to assure attaining the V_x indicated-airspeed and clearing any obstacle. Upon clearing any obstacle, clean the configuration, assure continued acceleration, and begin normal climbing flight.

Soft-Field/Rough-Field Takeoff

Configure the aircraft in its climb configuration for soft-field takeoff. Some aircraft will use a minimum flap setting. This is determined from the aircraft POH or from prior flight test.

This procedure requires aerodynamically lifting the aircraft as soon as possible to reduce the rolling drag from surface contact. Initial input of aft elevator loading will reduce nosewheel drag and more quickly attain a positive angle-of-attack.

As the aircraft accelerates to its minimum liftoff indicated-airspeed, add positive pitch up causing it to begin flight. Then use gradual leveling to maintain maximum ground-effect for acceleration. Upon attaining the desired climb indicated-airspeed, configure the flaps as necessary, and continue normal climbing flight.

Obstacle Clearing Takeoff

This requires determining the V_x climb angle, the point of rotation, and the angle from the point of rotation to the top of the obstacle. If the angle from the rotation point is less than the climb angle, it will be possible to clear the object.

For takeoff, clearance of obstacles requires attaining the kinetic energy necessary to sustain the V_x optimum climbing indicated-airspeed.

If necessary, maintain the flight in ground-effect with visual sighting toward the base of the obstacle. Upon attaining V_x , adjust the attitude to have the top of the obstacle unmoving or moving downward as sighted in the windshield.

Takeoff planning toward an obstacle requires knowing the aircraft takeoff roll, climb angle, and the angle from the liftoff point to the top of the obstacle. 



Chapter 6-----LANDINGS

This chapter presents Normal, Short-field, Soft-Field, and Crosswind landing procedure. There is discussion of different situations, conditions, and techniques available for making these landings.

Considerations

The basic considerations to be made for any landing are; the airplane configuration and indicated-airspeed for its gross weight, weather and winds, runway length, condition, and obstacles. From this, you can obtain the indicated-airspeed and procedures for the approach to landing.

The landing and rollout procedures depend on the runway length, condition and any wind effect. There are many different scenarios to consider for different conditions, and configurations.

Accuracy of the Landing Point

Landing approaches should be a visual directed-course to a planned aim point/landing spot/specific area. The touchdown will vary, depending on conditions during the landing and runway length, but always within a planned area.

All landings require consideration of available rollout distance from the actual touchdown area. Failure to touchdown near the approach end may require a go-around if sufficient runway rollout available is questionable.

Any headwind component reduces the ground speed, which aids in reducing the landing roll distance. A tailwind component adds considerably to touchdown velocity and length of landing roll.

Landings are minimum indicated-airspeed, on-area touchdowns, then, deceleration with braking as required.

Forward-Slip

When sighting going high on an approach forward slipping can increase descent rate. Enter the forward-slip with application of full rudder in one direction and aileron in the opposite direction for control of heading in the desired direction.

This type of maneuver turns aircraft sideways into the direction of motion creating added drag to cause increased descent rate. Normally use forward-slip in conjunction with use of flaps for controlling descent rate without increasing indicated-airspeed.

When sighting that the runway is moving back to the desired sight picture, gradually reduce the control input back to normal descending flight toward the runway landing spot.

Side Slip

Side slipping procedures during roundout, flare, and touchdown require use of the rudder steering the aircraft in the direction of motion for main wheel alignment with the runway direction, and coordinated opposite-directed aileron banking for using the horizontal component turning force to counter any crosswind force.

The coordinated banking maintains runway centerline alignment throughout the slipping maneuver. The upwind main-wheel will touchdown first in the banked attitude. All other control is as required for directional steering and braking.

Roundout and Flare

When approaching the runway end, being close to the ground, forward sighting moves along the runway centerline toward the far end, the sight picture becomes that previously seen of the aircraft at takeoff. The ground, sighted peripherally, will begin rising alongside the aircraft.

Roundout in a small aircraft begins 10-15 feet above the ground. The roundout is leveling of the descent with aft elevator-pitch control to reduce the descent rate and increased angle-of-attack to slow the indicated-airspeed.

As the aircraft slows, it should continue slowly sinking. Coordinated aft elevator pitching allows slowing both the descent rate and indicated-airspeed. As the aircraft approaches the surface for touchdown, the leveling control for roundout continues to flare the nose up slightly, allowing main-wheel touchdown before the nosewheel.

Holding the nose up continues until slowing allows nosewheel touchdown gaining positive ground to wheel rudder-steering control.

Landing

At the landing roundout, steering is with the rudder for heading control. The rudder aligns the wheels to the direction of motion for touchdown. Cross-control banking with the ailerons for maintaining centerline tracking causes a horizontal turning force to cancel any crosswind effect that may exist.

Directional control at this time requires the alignment of the longitudinal axis (the aircraft fuselage) to be in the direction of the aircraft motion parallel to the runway for touchdown.

Rudder control steers to align the aircraft directionally and opposite aileron control turning slips the aircraft side to side to keep alignment centered down the runway. Rudder steering will continue the directional controlling after touchdown as the aircraft will then be in a high-speed taxi condition.

Normal Landings

A normal landing can be to any runway or field, of sufficient condition, and length, to allow touchdown, and rollout, without any significant control requirements. An improved, firm surface, of sufficient length, to allow gradual braking to stop, is a normal landing.

Approaching the touchdown area, coordination of reducing power, with roundout (leveling), followed with pitching the attitude (flare), position the aircraft attitude for touchdown.

This maneuvering pitches the nose to allow reduction of indicated-airspeed and slow the descent rate. Continuously apply some aft elevator-pitch input as necessary, through roundout leveling, and nose up flaring, to maintain an attitude approximating the initial takeoff attitude, until touchdown.

Coordination with power reduction or adjustment, pitching up for slowing and gradual sinking allows the touchdown on the main wheels, while keeping the nose slightly off the ground.

It should be the verbally stated goal, for every landing, to touchdown at a specified area, and if not landing there, to consider the necessity of a go-around.

A situation that overshoots the touchdown area, with too much indicated-airspeed will cause floating from ground-effect, possibly leading to runway overrun.

Touchdown

Once on the surface, the ground to tire friction and the availability of braking will stop the aircraft. Check braking response in adequate time, to insure stopping the airplane on the runway. If initial braking seems inadequate, consider adding power to go-around.

If it is a normal landing, light braking is sufficient. A soft-field landing may require no initial braking. If it is a short-field landing, full braking up to the maximum possible could be required.

Though having tested the brakes on the approach checklist, maintain aircraft control and gently test the brakes immediately after touchdown on every landing.

It is seldom necessary to retract flaps during rollout. Distraction and the possibility of actuating a wrong control are ways to make mistakes. The reduced lift raising flaps is not worth worrying about unless the field is extremely short.

Throughout all the short final approach, landing, and rollout, the rudder controls heading. Most normal landings will be with the engine power gradually retarded to near or at idle, from roundout through the rollout.

Airplanes with “T” tails in the slowed tail-low approach configuration can often use some minimum power for propeller-blast to maintain sufficient pitch control during the flare.

The objective of a normal landing is to minimize the sink rate for the touchdown at the designated landing area and a minimum indicated-airspeed that approaches the stall indicated-airspeed. The touchdown should be on or slightly beyond the projected touchdown area, and aligned on the center of the landing area.

An advanced technique for attaining softer touchdown is to release a slight amount of aft elevator control when sensing touchdown is imminent. Most aircraft have the main gear aft of the static center of gravity so this causes a slight lifting of the wheels at touchdown thereby reducing the touchdown vertical force.

After touchdown, the continued deceleration will allow the nose to lower, and thus make possible ground friction steering. The rollout is a decelerating high-speed taxiing condition, and controlled with the rudder, for steering, and light braking, as necessary, slowing for turnoff and stopping.

Soft-Field Landing

A soft-field landing is a normal approach with a minimum indicated-airspeed touchdown. Little or no braking may be required.

After touchdown, hold the nosewheel off with full aft elevator-pitch control aided with use of propeller-blast if necessary. Power helps keep rudder steering and elevator pitching effective longer while countering any adverse surface or crosswind effects.

Power application, throughout the complete rollout, could be necessary to prevent becoming mired in extremely soft fields.

Short-Field Landing

A short-field landing is to a runway, limited in length, to the actual distance required to land and stop within its confines. Such a landing requires minimum indicated-airspeed at touchdown, with assured touchdown at the selected touchdown area. This ensures the remaining available distance for rollout, with moderate to heavy braking, bringing it to a stop.

Slower indicated-airspeed is adequate, unless turbulence or wind gusts exist. In that case, it may not be the place to land.

A positive landing (no float) on or near the chosen area then placing the nose down promptly and maximum braking if required. If there is floating, and/or you are landing long, immediately initiate a go-around.

Landing over an obstacle

Configure for the approach early, to allow stabilized control, and passing closely over the obstacle. Flying at normal approach configuration and reduced approach indicated-airspeed, direct the aircraft sight picture toward the top of the obstacle (Directed-Course) as if using it for the landing area. This will assure clearing over the obstacle at a minimum distance.

After passing the obstacle, resume a Directed-Course to the landing area. Maintain the trimmed approach indicated-airspeed, and land as normal.

Crosswind Landings

Planning for an approach starts when first receiving any wind information. Consider what the expected headwind and crosswind components affecting the flight may be before reaching the airport or entering the traffic pattern.

The crosswind component of landing winds can be quickly estimated using the basic trigonometric relations of 30/60 and 45/45 degree triangles.

A wind 30 degrees away from the runway heading will have a crosswind component of .5 (one-half) and a headwind component of .9 (nine tenths) of the total wind speed. A wind coming 45-degrees from the runway heading will have both crosswind and headwind components of .7 (seven-tenth) the total wind.

You can quickly estimate wind components relative to the runway heading when the wind is close to these angles. An estimate is enough to be aware of the expected control requirements for the approach. The wind is seldom constant and often varies from reported winds during the approach. There is no way to know or any reason to be concerned of the exact wind speeds. Close is good enough. Just remember .5, .7, and .9, for crosswind components of 30-45-60 degrees off the runway heading.

Small aircraft crosswind approaches are typically at 70-90 knots indicated-airspeed. With any substantial headwind component, the groundspeed will be close to 60 knots or one mile per minute. The approach heading correction then will be almost one degree per knot of direct crosswind component. Faster aircraft will use less heading correction for the same wind drift. A 120-knot groundspeed will use one-half degree crosswind heading correction per knot of crosswind.

On final approach, you align the airplane tracking with the center of the runway by crabbing. Just correct toward the wind those few degrees when turning onto the final approach. You will be close for establishing an initial heading and then can adjust as necessary. It's

not an exact science. Just fly the airplane, visually controlling making it go where you want to go.

No matter, whether you know the wind or not, if the offset visual landing area is not moving sideways, you have it right.

Crosswind Landing Touchdown

On short final approach, you align the airplane tracking with the center of the runway by sideslipping. The final approach at touchdown requires this slipping maneuver applied before touchdown to assure longitudinal axis (main wheel) alignment paralleling the centerline of the runway. The direction of airplane motion controlled by banking into the wind allows tracking alignment down the centerline.

No matter when the approach sideslipping is applied, the touchdown must be with the aircraft aligned with its direction of motion, and banking turned into the crosswind to prevent main wheel side skidding at touchdown.

When making a crosswind touchdown, the aircraft will be in a banked attitude from the slipping maneuver. In this attitude, the upwind main wheel will touchdown first. Main wheel contact on the surface begins wheel/ground friction and even is some skidding should occur, the momentum of the airplane will cause it to want to track in the direction of motion. As the aircraft slows, the second main wheel will touch down, followed shortly, with letting the nosewheel down.

A significant factor, for crosswind landings, requires available rudder-control steering to assure maintaining main wheel tracking alignment during the slipping maneuver and for continued directional control during deceleration of the landing roll.

Crosswind Landing Control

Additional control consideration with crosswind landing approach is the use of ailerons. The sideslipping maneuver is rudder and aileron application cross-controlled to maintain the desired tracking down the runway.

The ailerons, turned into the wind, cause a banked turning attitude creating a horizontal force offsetting the sideways drifting force of the crosswind. Opposite directed rudder input offsets the turn generated by the banked attitude, steering the alignment of the aircraft's wheels and thrust for forward tracking.

The visual sighting down the runway will be a banked attitude with aileron into the crosswind, simultaneously using opposite rudder, steering the aircraft main wheel alignment to the direction of motion.

It becomes simply adjusting bank angle side to side for control of side drift to maintain runway centerline tracking, and rudder input, yaw/steering for main wheel alignment to the direction of movement.

Crosswind Landing Rollout

At touchdown and rollout, rudder input controls steering and maintains directional control. Increased aileron after touchdown to maximum throw toward the wind aids in preventing possible wing lift from encountered wind and wind gusts.

During touchdown and rollout, the crosswind component against the large aft surface area of the aircraft side can cause a strong weathervane turning force.

When touchdown and rollout occur, wheel friction stops side drifting caused by the crosswind. However, weathervaning will continue, and this effect will increase, as the airplane loses its relative-wind with slowing of forward movement.

The forward movement of the airplane causes airflow (generated wind) along the vertical control surfaces, allowing rudder steering effectiveness for directional control and countering of the crosswind weathervaning force.

When slowing, to maintain more relative airflow along the airplane, it is possible to add some power, obtaining propeller-blasting wind, to prolong rudder effectiveness for added steering control. When using power to maintain rudder authority during the landing rollout, careful braking can still be used for deceleration.

In strong crosswind conditions, the technique of adding power to generate windblast from the propeller to reduce the crosswind effect will also be required for directional control while taxiing.

Crosswind and Tailwind Landing Considerations

Additional consideration for crosswind landings is the groundspeed incurred. If the wind is other than direct crosswind, it is possible to have a significant headwind component resulting in relatively slower touchdown groundspeed, this results in a shorter landing rollout.

Increasing indicated-airspeed to counter possible wind gust effects is a usual technique. As a quick reference, a pilot can fly an approach indicated-airspeed up to the normal groundspeed of a no-wind approach. This is equivalent to adding the landing headwind component to the approach indicated-airspeed.

With tailwind landing, when slowing the airplane transits the groundspeed at which relative-wind of forward movement, versus any tailwind component become equal, there will only be crosswind on the rudder. This situation could cause directional control problems if not considered. It can be expected nosewheel steering should be available, or again, propeller-blast may be required.

It may be especially significant for aircraft with castoring nose wheels though individual wheel braking should be available during this time.

There is still always an option to add power for propeller-blast to regain or maintain rudder control.

Extreme Crosswind Landing Situations

During the landing rollout in strong crosswind situations, the use of power is a significant aid in directional control. The pilot must learn to assume it will be necessary to use some power with reduced flap during any crosswind landing and rollout. A landing will require this technique, in all situations of unusually strong crosswinds.

Normal landing procedures, with idle power at touchdown and rollout, develop habit patterns that may not be appropriate in the crosswind-landing situation.

If, at any time, it becomes apparent there is becoming insufficient directional control to maintain runway tracking during a landing rollout and sufficient runway remains, it may be necessary to initiate a landing roll go-around.

The increased full power propeller-blast and acceleration of relative indicated-airspeed may regain directional control for a successful go-around takeoff. This requires immediate initiation upon any awareness of marginal directional control. It also requires consideration of there being sufficient runway remaining.

Anytime control begins deteriorating, add power for propeller-blast, even up to takeoff power. Cautious full braking may be required; whatever it takes to maintain rudder and nosewheel steering control.

Emergency Crosswind Landing

Landing at airports when strong crosswinds exist sometimes requires some “out of the box” thinking. Some pilots may decide to try making a crosswind approach and find they are not proficient enough to continue. As with all flight, there must be alternative action available.

Making a go-around from the initial approach is often the best decision. You can now consider where you went wrong, and fly a second, or third, better controlled, approach for landing. Often in strong winds, there are gusts followed by lulls of lesser winds. Making several approaches until arriving at a period of lull may be required.

Landing on a runway more aligned with the wind or angling slightly across a wide runway could be an obvious alternative for a small aircraft. If there is no other landing runway, the flight must consider any available alternate airport, if fuel and weather allow.

Without this option, it could be you must declare an emergency, and will have to make a decision to keep the airplane and its occupants safe.

Such options, which could exist in an emergency, would be landing where there is no crosswind, such as a taxiway, a road, or open field aligned with the wind.

Landing into a strong headwind reduces the landing roll considerably. A 40-knot headwind with a 50-60 knot approach speed can make an emergency landing a feasible option.

Thinking of an emergency scenario for the destination area becomes a significant part of the planning. Consideration of emergency options ahead of time allows more confident and appropriate decisions should a time come to deal with a strong crosswind.

High Wind Taxi Operations

It requires consideration of control positioning for all taxi operations in windy conditions. The ailerons, turned into the wind, and the elevator-pitch control using propeller-blast for holding the tail aid in avoiding any undesired lifting from wind effects. This applies to all takeoff, landing, rollout, and taxi operations.

Exercise care in any high wind taxi operation. Taxiing with engine power for blasting air across the airfoils can reduce crosswind effects substantially. In addition, when changing the direction of taxiing, turning requires careful planning of control positioning.

Parking without outside help requires consideration. It could be necessary to park next to a tie-down anchor faced directly into any wind, setting the brakes, leaving the power at a setting to offset the wind effect.

That could allow quickly exiting the aircraft to fasten a tie down, then shutting down the engine. Such an operation will require extremely careful consideration and awareness of the turning propeller.

An encounter of extreme wind, such as a passing gust front, could require parking when taxiing, facing into the wind, and using power, with the brakes set, while waiting the gust front passage.

An alternative might be, if time allows, taking off with flight away from the extreme phenomena until it passes, with a landing at an alternate airport, or circumventing the weather and then returning, to land after passage.

Landing With One Brake Inoperative

Finding an inoperative brake upon landing requires prior knowledge of and consideration of what can happen. Initial testing of brakes should occur during the approach checklist, and again just after touchdown with the aircraft under rollout control, gentle application of brakes after touchdown should be normal procedure.

Becoming aware of an inoperative brake at this time, there should still be some rudder authority for steering. There must be an immediate decision of applying takeoff power and going around or if there is not sufficient runway, apply nose down elevator for maximum nose wheel steering authority.

Gentle application of braking as steering control will tend to turn to one side. Opposite steering with release of braking will turn the aircraft back. Alternate turning and gentle braking will result in zigzagging along the runway. You can expect substantially longer landing roll.

Maintaining this directional control may be marginal and if exiting the runway, it still may be possible to direct toward areas for minimizing any damage.



Chapter 7-----HIGH ALTITUDE FLIGHT AND THE ATMOSPHERE

This is discussion of the factors related to high-altitude flight operations and the effects on engine performance in low-density air.

The reduced availability of oxygen for burning affects all engines so in many situations there may not be sufficient excess thrust available for takeoff or safe maneuvering.

High-Altitude Flight

Every week someone crashes during takeoff from a high-altitude airport. The reason is often the pilot's lack of understanding of how low-density air affects engine performance.

The normal assumption as taught is that aircraft will not fly as well at high altitudes as at low altitudes. This is a very broad generalization based on limited understanding of the physics involved. It is not the air; it is engine power and propellers.

With low-density air, the engine cannot produce its maximum rated power and rpm limitation of the engine will not turn a fixed pitch propeller fast enough to cause the normally expected mass thrust. These are huge factors against attaining required acceleration for takeoff.

With combinations of high elevation, high temperature and/or high humidity, and being no visual reference of reduced thrust during ground operation and takeoff, it requires very careful planning and consideration of all factors related to the aircraft performance to assure any safe takeoff. An understanding of the atmospheric density and the factors related to engine power is essential.

Atmosphere

The earth's atmosphere is an enormous mass covering the earth's surface and extends miles upward into space. It contains a mixture of approximately 78% nitrogen and 21% oxygen along with some small quantities of other elements.

We cannot see these gases, but even so, air has these elemental quantities of mass, so has weight. The earth's gravitational force pulls the molecules of air toward the surface, piling them on top of each other. Molecules of the air become packed densely at the surface and gradually less dense as altitude increases. We often refer to this as thinning of the air as altitude increases.

A standard measurement of pressure exerted by this piling of the air is by barometrically measuring the lifting of mercury in a closed tube.

The accepted atmospheric pressure standard measurement at sea level is 29.92 inches of mercury (1013.5 hPa).

Atmospheric pressure change is the basis of operation of the altimeter instrument used for indicating flight altitudes.

Motion through the Atmosphere

The aerodynamic “lifting” effect of mass displacement by motion through the atmosphere allows airplanes to fly with much less power than would otherwise be required. The properly designed aircraft moving forward at sufficient velocity is “lifted” by the forces developed when displacing the mass of the atmosphere, and when these forces are balanced an aircraft “becomes suspended” within the atmosphere.

Without that mass of the atmosphere, all flight would require enough power to fly straight up and sustain that power to remain airborne. A continuous 1,600 pounds of vertical thrust would be required to sustain flight of a 1,600-pound aircraft.

In the normal case of aerodynamic lifting from motion through the mass-of-the-air, it takes approximately a 10 or 12:1 ratio of weight to thrust to sustain most small aircraft in flight. A 1,600-pound aircraft requires approximately 160 pounds of thrust to sustain level flight at its optimum, constant indicated-airspeed (pressure speed). However, this requires a power source, the engine, continuously generating the necessary sustaining thrust to cause that velocity.

Air Density and Your Aircraft

Maintaining a constant indicated-airspeed pressure, when climbing to higher altitudes into the gradual thinning air (reduced mass per volume of the air), requires that the velocity within the air mass must gradually increase to maintain a constant air mass encounter.

We call this velocity within an air mass “true airspeed”. The increased velocity maintains a constant mass encounter for a constant sustained lift. The airplane flies at an indicated-airspeed pressure. The temperature, wind, and density altitude affect the current conditions of the air, but only the encountering air displacement pressures and related reactive forces affect the aircraft lift.

As long as the indicated-airspeed pressure is at or above the required minimum, it continues to fly in the direction controlled.

If your aircraft does not have the engine power to maintain a minimum indicated-airspeed pressure, it will continue to fly, but will descend adding gravity component-thrust to sustain the set elevator pitched indicated-airspeed.

In descent, supplemental gravity component-thrust will always add to maintain the sustaining thrust, until the engine power available is again capable of level flight...or contact with the earth's surface.

HIGH ALTITUDE TURNS

Example: Maximum Bank Angle for Level Constant Indicated-Airspeed Turn
 9,000 ft. Density Altitude, 260 lbs. Maximum Thrust Available
 Assumed 1600 lb. aircraft at 6-degree angle of attack (Vy IAS.)
 requires 160 lbs. sustaining thrust. (10:1 weight to thrust ratio.)
 There is 100 lbs. Excess Thrust Available

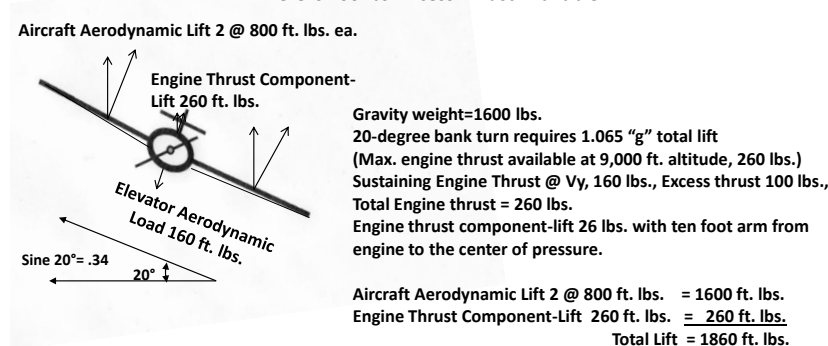

Fig. 7-1

Air Density and the Engine

Density of the air through which you fly varies according to atmospheric pressure, temperature, and humidity. One-half of the total atmospheric mass is compressed below 18,000 feet. This means a unit volume of air compressed at the surface will have twice the mass as a unit volume at 18,000 feet and so the amount of oxygen mass in a unit volume at sea-level will have twice the oxygen mass as that same volume at 18,000 feet.

Engines must have oxygen to burn fuel. An airplane engine's fuel/air-induction system has a fixed size routing and can intake only a certain volume of air. Therefore, the reduced available oxygen mass per unit volume at higher altitudes limits the possible power of engines.

In higher altitude, temperature, or humidity low air-density conditions, the engine cannot intake a mass of oxygen for burning enough fuel to produce its maximum rated power.

Though increased velocity compensates the effect of reduced density for indicated-airspeed pressure, the reduced availability of oxygen dramatically affects the engine power available. Higher altitudes, temperatures, and levels of humidity all mean reduction of oxygen intake for burning in the engine.

When climbing to higher altitudes, the available engine thrust gradually decreases so the climb rate also gradually decreases. At some maximum altitude, the climb rate will become zero and the engine will be producing only its sustaining thrust for the set indicated-airspeed. At this maximum altitude (absolute altitude) V_x and V_y become equal.

The aircraft will then be flying level at that same constant indicated-airspeed at this maximum altitude.

Air Density and the Airport

A pilot must be very aware of the reduction of engine performance at high-altitude airports. An airport at a 6,000-foot elevation on a hot, humid day can have an effective air density equivalent to 8-10,000 feet. The performance of the engine will significantly degrade, possibly having no more than 100-150 pounds of excess thrust available for takeoff. A pilot must be extremely careful when calculating takeoff performance in these conditions.

The appearance of long runways at high altitude airports can be deceiving. With reduced power and related thrust from the propeller, the takeoff roll is going to be significantly longer than at low altitude runways. It still requires attaining V_y for continued flight so there will be a long takeoff roll, which may leave little excess runway for stopping if an abort becomes necessary. Short-field takeoff procedures may be appropriate even with a very long runway.

Air Density and You!

The regulations require beginning use of supplemental oxygen when above 12,500 feet. However, the need for oxygen relates to an individual's actual physical condition.

Many pilots would be safer if they considered using some oxygen when operating at substantially lower altitudes. Though not showing or feeling symptoms of hypoxia, lowered physical response can still affect the operation.

Additionally, passengers on longer high altitude flights will find the use of supplemental oxygen will have them feeling better at the end of the flight.

High Density Atmosphere

An opposite aspect of extreme temperature is cold weather. Cold weather altimeter readings when set at a local field elevation will have the aircraft flying as some lower altitude than indicated. This may be obvious in visual flight conditions when low to the ground, however, instrument approaches in IMC must consider that the aircraft near sea level altitudes can be as much as 100 to 200 feet lower than the altimeter reads.

An example may be at minus 10-degrees C, at 1000 feet the aircraft will be up to 100 feet lower than the altimeter reading, at 2000 feet it may be 200 feet lower than the altimeter reading. An approach over mountainous terrain may put the aircraft lower than required minimum clearances.

Flight in these conditions requires adding that correction to the altitude being flown, i.e., to be at 1,000 ft., the pilot must fly an indicated 1,100 ft.

Engine Power and Engine Power Rating

Engine power is what sustains the aircraft in level and climbing flight. When maintaining a constant indicated-airspeed, constant altitude, wings level flight, the engine power is providing the sustaining-thrust.

At any altitude or attitude, it requires a constant mass-of-the-air displacement with its constant encountering pressure for the selected indicated-airspeed condition.

Manufacturer rating of engines are determined with the use of sea-level standard conditions. A 110-horsepower-rated engine can produce the 110 horsepower only at sea level on a standard day. The typical aircraft with this 110 horsepower engine in the standard conditions is capable of producing approximately 460 pounds of thrust.

In the lower atmosphere there is an approximate linear pressure reduction as altitude increases, and for this reason, engine power gradually decreases during climb. As an example, if your engine/propeller, at full throttle, produces 460 pounds of thrust at sea level, but will produce only its sustaining thrust of 160 pounds at slightly below 12,000 feet, this is a 300-pound reduction of thrust available.

In this example, there is a 25-pound reduction of thrust for each 1,000 feet of increased altitude. At 5,000 feet, you can expect to have 335 pounds of thrust available but only 175 pounds of excess thrust for maneuvering. At 10,000 feet, you will have 210 pounds of thrust available but only 50 pounds of excess thrust for maneuvering. At 12,000 feet, there will be only 160 pounds of thrust, leaving no thrust available for maneuvering without descent for adding gravity component-thrust.

Engine Fuel/Air-Induction

The conditions of atmospheric temperature, humidity, and pressure affect the power output of air-breathing engines. In addition to the reduced oxygen available, the atmospheric pressure injecting the air into the induction system decreases, so also contributes to the continuous reduction of engine power as altitude increases.

Low-density air and the resulting reduced oxygen per unit volume requires reduction of the fuel (leaning the mixture) to maintain optimum fuel-vapor/air ratio for proper burning. Leaning with the mixture control reduces fuel to maintain proper burning but results in reduced power output. The result of the leaning procedure is a gradual reduction of available fuel, resulting in engine operation as if slowly retarding the throttle throughout climb.

Small Aircraft Thrust Performance

On a standard day, at sea level, the engine of a typical 1,600-pound aircraft at idle power will produce approximately 70 pounds of thrust and at full forward throttle a maximum power of around 460 pounds of thrust.

Sustaining flight means having enough thrust to allow the passage of the aircraft through the air at a constant displacement pressure. In this example of a small aircraft, we have said it takes 160 pounds of thrust to sustain constant altitude level flight at its optimum V_y indicated-airspeed.

At any constant indicated-airspeed, there is a required constant sustaining thrust. It does not matter the attitude, altitude, or direction of flight. At all times, it requires that specific sustaining thrust, for a particular constant indicated-airspeed condition to displace sufficient mass-of-the-air and maintain the encountering air pressure for that indicated-airspeed.

The same aircraft, with a more powerful engine, will continue climbing to some higher altitude, at which it eventually will produce only the required minimum 160 pounds of sustaining thrust.

That will then be the absolute ceiling for the aircraft with the more powerful engine. At that higher altitude, the aircraft will maintain a level flight attitude at the same sustaining indicated-airspeed until changing its conditions.

If this aircraft engine provided 160 or more pounds of thrust at thirty thousand feet, it could continue climbing to that altitude. The thrust available to sustain the aircraft is the limitation to flight altitudes. Limitation to flight performance relates to the availability of thrust.



Chapter 8-----STALLS

This chapter discusses maneuvering at slow indicated-airspeed and conditions that lead to inadvertent stalling of the aircraft. Emphasis is on avoiding the stall, and in the event of a low altitude stall, recovery with minimized altitude loss.

Stall

Stall is a condition of attaining an extreme angle-of-attack until the wings can no longer develop lift. This is a pilot induced condition caused by holding aft elevator input.

There is a huge history in aviation related to stalling and a related emphasis on training regarding stalls. It is common for accident evaluations to call aircraft accidents and incidents the result of stalling and crashing.

It is true; low altitude stall leading to an accident often occurs during excessive maneuvering for an approach to landing and/or emergency off-field landings.

A stall is always the result of pilot input, pulling on the control wheel, allowing an autopilot to control...all pilot input. Continued aft elevator control causing stall can lead to a spin. Expect loss of altitude during stall recovery.

We previously found that pulling on the control wheel causes increased elevator-pitched angle-of-attack allowing reduced indicated-airspeed. Therefore, it seems obvious maybe we shouldn't pull on the control wheel so much when maneuvering at low altitudes and operating at low indicated-airspeeds. Be very aware of the consequences of any pulling of the control wheel.

When maneuvering at slow indicated-airspeeds, if things aren't going right, adding power will usually solve the problem. If sufficient power is not available, then you must use gravity with loss of altitude. No matter the case, if below V_y or at any lower approach-configured indicated-airspeed, continued pulling the control wheel is often the wrong solution.

It is important to note, when stalled, the acceleration of gravity is a thrust effect equal to the weight of the aircraft. That may be as much as four times maximum engine thrust. Things begin happening very fast.

Elevator-Pitched Critical Angle-of-attack

There is a limit for increased elevator-pitch and related reduced indicated-airspeed maneuvering. At some maximum elevator-pitched angle, attaining wing critical angle-of-attack, the airflow over the

surface of the wings will be unable to maintain its conforming laminar flow along the surface, and will break away, causing a turbulent flow area across the top surfaces of the wings with increased induced drag and loss of lift...a stall.

Critical elevator-pitch is the aircraft elevator-pitched angle above the direction of motion that causes loss of conforming airflow over the wings. This happens to all aircraft at some higher angle-of-attack. The indicated-airspeed is the instrument that indicates being slowed toward critical angle-of-attack, however, because of different mass or “g” loading considerations, only a stall warning system or probable aircraft shaking or shuddering will indicate close or at stall. When slowed, a pilot must know stall will occur if holding the nose pitched up with elevator input.

The critical wing angle-of-attack pitch varies with each wing form. For most aircraft, it will be between 15-20 degrees of nose up pitch to the relative-wind. It is all about the form of a wing, always in the same pitch range above any relative-wind of motion, whether level or moving at some climb or descent angle.

A particular wing design stalls at one specific angle-of-attack. The critical angle-of-attack is not a function of aircraft weight. Aircraft weight is a function of required lift. A heavier aircraft operates at a greater angle-of-attack to cause sufficient lift. This means the heavier the aircraft, the closer it operates toward the critical angle-of-attack.

Maneuvering that causes increased “g” loading, causes the aircraft to become heavier. Therefore, with large “g” loading, the indicated-airspeed at which the aircraft reaches the critical angle-of-attack is greater.

The attitude of the aircraft does not necessarily relate to the critical pitch angle. The angle-of-attack is above the climb angle or descent angle and always above the direction of motion.

In any climb, your aircraft nose pitches to a steep climb angle with a new direction of motion using the excess engine power. The relative-wind, opposite the direction of aircraft motion, always follows the excess powered climb-pitched angle.

Aircraft Pitch Control

Elevator control and the engine thrust component-lift are aircraft pitch attitude control. We know pitching up with the elevator allows deceleration of indicated-airspeed.

This requires understanding that an elevator trim setting with coordinated sustaining engine or gravity component-thrust allows the aircraft to fly at a set indicated-airspeed. There normally becomes little need for excessive elevator-pitch control.

We found that the excess engine thrust, above the sustaining thrust of constant indicated-air-speed level flight, causes climb pitch and increased altitude. We also now know the portion of the engine thrust component-lift in level flight is causing part of the angle-of-attack.

What happens when reducing thrust?

In descent, it is common to re-trim the elevator for a desired constant indicated-air-speed. An increase of engine thrust now will first cause reduced descent rate and slowing up to level flight, then any excess thrust when reaching the new slowed level flight there will be continued increasing altitude (climb).

From a descending attitude at a trimmed indicated-air-speed, increased power adds back to the angle-of-attack allowing deceleration until reaching the sustaining powered, level flight attitude for the new combined elevator and engine pitched angle-of-attack. Any excess power at that time will continue the attitude into a climb at the new reduced indicated-air-speed as set with this current elevator-pitch trim setting.

An example would be considering a coordinated V_y level flight with a 6-degree angle-of-attack. Three degrees are from elevator-pitch and three degrees from engine thrust component-lift.

If reducing power to idle, the engine-lifting might now be one degree causing the effective angle-of-attack to become 4 degrees. This reduced angle-of-attack will allow some acceleration, so applying two degrees of additional elevator-pitch effect allows deceleration of indicated-air-speed back to the original V_y angle-of-attack.

The descent continues to a desired altitude at which leveling by adding power regains the two degrees of engine lifting. The regained lifting adds to the approximate five degrees of elevator pitch in effect. Now at seven degrees angle-of-attack, this allows deceleration, so to maintain the V_y indicated-air-speed angle-of-attack, reduce elevator-pitch back by those two degrees.

This shows that when maneuvering with reduced power in descent, the angle-of-attack control requires continuous coordination of elevator-pitch with any power change to enable constant indicated-air-speed flight.

Elevator pitch coordination upon leveling from descent returns the angle-of-attack to the prior condition and again excess power applied causes constant indicated-air-speed climb without the need for changed elevator-pitch.

We found earlier that descent operation below level-flight sustaining thrust settings required some added up elevator trim for maintaining the original constant indicated-air-speed. Now you can always expect

any descending operation, as for landing approaches, to respond from power increase with increased angle-of-attack pitch allowing slowing.

It will always require some push on the elevator control and coordinated nose-down elevator trim to offset the pitch-up from power increases for maneuvering in constant indicated-airspeed descent.

Power Stall

The discussion to assure understanding that the pilot causes all stall by pulling the control wheel must be tempered by discussion of power effect on angle-of-attack when increasing power in descent.

We have discussed the necessity of increasing elevator trim in descent to maintain constant indicated-airspeed. If we look at a simulated condition of slow indicated-airspeed for an approach there could be at least five to eight degrees nose-up elevator trim and one or two -degrees idle thrust component-lift contributing to the total slowed approach indicated-airspeed.

If maneuvering in a descending turn with added manual aft elevator there would be additional slowing with possibly a total of 12 to 15 degrees total wing angle-of-attack. A large power increase at this time will add thrust component-lift of as much as 6-degrees to the wing angle-of-attack...instant stall!

Slow indicated-airspeed descending flight maneuvering must always be with consideration of how manual elevator and power together can affect angle-of-attack.

Stalling

Increasing elevator-pitch angle causes the airflow to deflect more and more away from the top wing surface, until reaching the wing critical angle-of-attack. At that point, the Coanda effect is lost, as the airflow can no longer follow the wing contour so breaks away with resulting turbulent flow and loss of lift.

With a positive dynamically stable aircraft, a stall can only happen by continued aft elevator-pitch control input from you, the pilot. If not pulling on the control wheel, there is no reduced indicated-airspeed, but merely descent with gravity component-thrust.

You must maintain normal operating procedures with minimum or no aft elevator and the use of power to assure the aircraft cannot attain wing critical angle-of-attack.

Normally stalling an aircraft will be only for demonstration to regulators of the ability to recognize approaching and recovery from possible stalling situations.

Stall Situations

All stalls result from pilot induced elevator-pitch angle creating an excessive wing angle-of-attack. Actual stall events typically are unwanted, unexpected and at low altitudes. For this reason, it is necessary the pilot be familiar with how each aircraft stalls, and how to recover rapidly from such an event.

A review of Appendix 1 will show the mental physiological effect of manual elevator control. This explains how it becomes likely to over control aft elevator input when maneuvering at slowed indicated-airspeeds.

There should be a review of the minimum maneuvering indicated-airspeed before every takeoff. It is just after takeoff, when at slow indicated-airspeeds that engine malfunction often requires immediate maneuvering that often leads to stall incidents.

The idea that you can stall the aircraft, with simply pulling on the control wheel, should alert you to how to avert a stall. Just don't pull!

There are, however, certain circumstances that have historically led to stalls, and, unfortunately, these situations typically occur during low indicated-airspeed, low-altitude maneuvering, often making it impossible to recover.

The control input forces become less during slowed flight as airflow pressures across the control surfaces reduce. The reduced pressure on control throw requires more input to get the same response and tends to hide the concept of approaching a stalling indicated-airspeed.

These situations, then, can lead toward the stall scenario, and if occurring at low altitude, are often with fatal consequences.

The attitude of your aircraft in a wings level stall is quite nose high, and normally easily recognized. However, the nose high attitude in a descending turn is difficult or impossible to recognize, which coupled with the mental physiology involved, adds to the tendency of continued input of extreme control. Coupled with an increasing stall indicated-airspeed from "g" loading, a steep banked turning stall can occur.

Any distraction when directing the aircraft toward a point, such as the low indicated-airspeed descending turn to a landing area, can divert attention from controlling and inadvertently forcing an attitude, rather than letting the aircraft fly.

It requires training of all pilots in how to consciously maneuver (adding power) with minimum manual elevator control during turns and awareness of the consequences of elevator-pitch input. The review of Appendix 1 will allow understanding of how manual control can inadvertently become too great.

Common Stall Scenarios

The following are the most common situations leading to low-altitude stalls resulting from excessive pilot input of aft elevator-pitch control.

1. Base to final approach turn; in this lowered indicated-air-speed, high drag configured turn, if the aircraft seems to be overshooting the final approach, it is human nature to want to continue into a steep bank and pull the control wheel in an attempt to correct back. A steep banked attitude with aft elevator control results in increasing the “g” loading with an associated increase of stall indicated-air-speed while causing reduced indicated-air-speed.

There must be a practiced and drilled discipline for you to be aware, and know how to make this turn safely. If you have to pull the elevator control in a steep turn, it may be time to abort the approach.

2. Having an engine problem at takeoff, and making a reduced power or loss-of-power steep turn attempt to return to the airport often results in inadvertent excessive elevator control input and again a low-altitude turning stall. Without training to know how to make this turn in every airplane you fly, it is likely best to continue ahead making an off-field landing.
3. Aft elevator-pitch input during takeoff when indicated-air-speed is at minimum initial flying indicated-air-speed can easily become a stall situation. This is more common in operation within low-density air of high-altitude, or short-field takeoff attempts to make it fly. Let it stay in ground-effect for acceleration to safe indicated-air-speeds.
4. Low altitude, slow indicated-air-speed, circling turns, when observing an object on the ground can lead to inadvertent loss of control. This is diversion of attention, trying to sight something on the ground and concentrating on that rather than flying the machine. This type of flight maneuvering is safer by trimming to hands-off at the desired indicated-air-speed, maintaining the level turn altitude with added power, changing bank angle with rudder steering, and releasing any aft control wheel input.
5. Normal landing flare is a common situation with slowing of the aircraft toward the minimum elevator-pitched indicated-air-speed. The intent is to touchdown just as approaching stall indicated-air-speed. If the roundout and flare are too high, it is possible to stall and have the aircraft drop a few feet onto the runway.

The landing stall can create a hard landing, with damage to the structure of the aircraft. The landing touchdown stall requires consideration of possible strut attachment damage, which may not

be visually identifiable. This may mean canceling the flight for a maintenance inspection.

How do you know it is a hard landing? There being no way to measure, the only way to know for sure...“If you thought it might have been, then it is!”

Elevator Trim Stall!

The elevator-pitched trim stall results from a go-around maneuver with your aircraft trimmed at the slower indicated-airspeed of a high drag configured landing approach.

When initiating the approach abort/go-around procedure, attempting leveling with aft control wheel input just prior to or as the power input happens, could cause attaining the critical wing angle-of-attack, a stall.

All approaches are at power settings below sustaining thrust for level flight. This is to allow the aircraft to descend toward the landing. This reduces the small thrust-component of lift from the engine power that resulted in adding aft elevator-pitch trim to maintain the approach indicated-airspeed.

When adding go-around power, the aircraft may pitch up more than desired. Increased angle-of-attack from increasing to and through sustaining thrust will increase the angle-of-attack, allowing more reduction of indicated-airspeed.

If propeller-blast is affecting the tail loading, there could be additional elevator-pitch effect allowing additional reduction of indicated-airspeed.

Excess power causing climb pitch creates a large nose up attitude change. The excess power can be causing climb-pitch, depending on thrust available, thereby adding a climb angle to the elevator-pitch angle results in an unusual nose high attitude though not necessarily approaching elevator-pitched critical angle-of-attack.

From the descending approach, it is common for you to think it necessary to pull the control wheel to level as you ram the throttle to this maximum go-around power setting.

Too fast response by pulling the control wheel, can easily happen at or before attaining the excess power input, and possibly cause stall indications, or an actual stall, as power increase creates its additional angle-of-attack and climb-pitch.

Without caution, the nose up trim of a low indicated-airspeed approach, with rapid power application, coupled with aft control wheel input for stopping descent, could easily come together for the stall.

Accelerated and Secondary Stall

It is possible to force a stall from any attitude or indicated-airspeed, including descent. An accelerated stall is from input of excessive aft elevator control forcing the attitude to exceed the elevator-pitched critical angle-of-attack before any slowing has occurred. This can happen from any attitude and indicated-airspeed situation.

A high indicated-airspeed dive attitude requires cautious coordination of control to avoid overstress of the wing loading while at the same time, exercising care not to cause excessive elevator-pitch input leading to attaining the critical angle-of-attack, an accelerated stall.

Secondary stall occurs during stall recovery as an accelerated stall. It is the result of too rapid and excessive up elevator-pitch following the initial down elevator-pitch input when initiating a stall recovery.

Introduction of secondary stall can be as an additional maneuver to the normal stall recovery demonstration.

Disturbed Air Encounter

If you could see air, it might be frightening!

There are other ways to cause inadvertent stall. Though you can stall the aircraft with aft elevator-pitch input by exceeding the elevator-pitched critical angle of the wings, it is possible to encounter situations, such as inflight air turbulence, or wake turbulence from the passing of another aircraft.

These situations generate high velocity vortices in the free-stream air mass that if encountered can cause a wing to stall or in some manner cause drastic lift change, perhaps only on one wing at a time.

Upset

An upset is a sudden, erratic, changed attitude. You can expect upset, rapid altitude change, or indicated-airspeed change with flight into extreme microburst winds, downdraft, or updraft, and lingering wake vortices, the disrupted random airflow caused by the prior passing of an aircraft.

Recovery from upset requires acrobatic flight maneuvering control. Extreme nose up or steep banked attitudes from upset can approach or lead to actual stall with improper aft elevator-pitch control input.

In an extreme attitude, awareness of the necessity to push the control wheel forward with coordinated input of the rudder needs to be firmly entrenched in the pilot's mind. Extreme pitch up may require banking the attitude to pitch the nose vertically down with rudder.

It is difficult to have a mindset to push if in proximity to the ground!

Microburst

Microburst is rapid change in direction of airmass movement associated with thunderstorm approach and passage across an area. Low altitude, high velocity, vertical winds are associated with thunderstorm passage. When encountered, this effect can cause extreme changes of indicated-air speed and altitude.

Avoidance of thunderstorm encounter is the primary way to handle this phenomenon. Inadvertent encounter may require maximum power to maintain controlled flight. Continued penetration through an area may not be possible with an aircraft, thereby calling for immediate turn away.

Large indicated-air speed changes can occur when encountering microburst winds. Low indicated-air speed approach configurations can create possible stall situations when passing through these rapidly changing winds. Consider increasing approach indicated-air speed to allow an air speed margin for passing through these conditions.

A landing approach through possible microburst conditions requires consideration of the headwind component of approach and landing winds. A reference for increasing the approach indicated-air speed is to attain the normal no-wind approach ground speed, creating a buffer in the event there is a sudden decrease of indicated-air speed.

The descending airmass in a microburst will slow as it approaches the surface. It is not likely a small aircraft pushed down will encounter the ground, but obstacles on the ground could become a problem. It requires some training to be aware enough not to pull on the elevator too much during such an encounter.

Wake Turbulence and Avoidance

Generation of large rotating masses of air (vortexes) by the volumetric displacement of a prior aircraft creates wake turbulence.

Wake turbulence encounters can cause extreme attitude changes to a following aircraft. These situations are not too unlike flying through a dust devil though the direction of the vortices may be different. In either case, there are unseen vortices of air rotating rapidly in different directions and result in unusual flight response as your airfoil passes through them.

The radical disturbance of air resulting from a preceding aircraft can drastically affect your following machine. The larger and heavier the machine passing through an air mass, the greater will be the displacement and vortex turbulence. In a static or slow moving air mass, these conditions may last for several minutes after passage of an aircraft.

A common wake turbulence encounter may cause sudden loss of lift on one wing before acting on the other. This can result in extreme banking attitudes (upsets) and corresponding loss of altitude. A natural reaction is input of full opposite aileron. Depending on the severity of the encounter, this may result in recovery.

An analysis of the force vectors, when close to a 90-degree bank, will show that proper rudder input at this time can help give a vertical nose up attitude, if required. Proper control input as in acrobatic maneuvering may reduce the tendency for loss of altitude during the recovery. It requires input of some down elevator control to reduce the elevator-pitch angle.

The process of proper control response requires pilot training for a natural reactive input, when encountering sudden, rapid, and extreme attitude changes.

Avoidance of possible unusual or extreme maneuvers or attitudes is always the best plan. Minimize encounters of wake turbulence by understanding the nature of wake generation and its behavior.

The cyclonic flow from a preceding airplane gradually dissipates while slowly drifting and descending in the direction of the general air mass movement.

Awareness by staying slightly above prior traffic is an operational practice. This means flying with the head not the rule.

It is not necessary to be “on altitude” if the airplane ahead is big and relatively close. Sneak up 50 or 100 feet. The system allows this. Fly a little to the upwind side of on-course. If runway length will allow, make your landing touchdown just beyond the touchdown of the airplane ahead.

Do not hesitate to go-around if not satisfied with the spacing or time for wake dissipation. Understand where or if wake turbulence can linger from the airplane ahead.

Air mass movement can be determined from the reported wind direction and speed. Calm winds allow wake turbulence to linger for considerable periods over the approach of the runway. Light winds crossing parallel runways can drift wake turbulence from one parallel runway to the other! At the first indication of any erratic flight behavior, immediately increase power and altitude.

Being suspicious of the possibility of wake encounter is a significant deterrent and allows much more rapid reactions. Be aware there can be lingering wake even from small aircraft during takeoff where they are using maximum power. Engine thrust's blasting-air cause's disruption of airflow similar to the volumetric displacement of aircraft passage through an air mass.

Understand that an encounter can result in at least momentary totally uncontrolled flight! Don't hesitate to go-around before the encounter if unsure of what might happen. Don't let the controllers influence your caution. Going around is always preferable to breaking the aircraft. You fly the airplane, not the controllers!

Practice Stalls

Prior to practice of stalling flight, inspect the aircraft to see that you have stored all loose items, so nothing can become a hazard in the cockpit. Assure seatbelts are tight.

When creating an attitude that approaches the maximum an airplane can fly, the slowing indicated-airspeed will cause reduced lift, increased induced drag, and gravity starting the nose down. This condition will cause acceleration by gravity, and the machine to continue flight.

If you input additional up elevator-pitch, an extreme pitched up attitude can result leading to more indicated-airspeed loss, and if continued, the aircraft stalls. The aircraft begins to fall. Falling from the gravity force of acceleration is with a thrust equivalent of the aircraft's weight. That is rapid acceleration accompanied with rapid loss of altitude.

Emphasize the comparison of control inputs that allow your airplane to operate safely, versus the inputs that created stalls. The stalls occur with added aft elevator-pitch control input by you, when attempting to maintain an attitude. Only with prior mental preparation and awareness of the maneuvering can you prevent excessive aft elevator input.

Stall Training

Excessive nose-up elevator-pitch control causes stall. Stalling can only happen with controlling to the critical elevator-pitched angle. This happens with aft/up elevator-pitch control input.

All practice stall scenarios result in increasing to the critical elevator-pitched angle to its related critical wing angle-of-attack. Increased elevator-pitch always allows the aircraft to decrease indicated-airspeed.

Initially fly the setup, configuration, demonstration, and flight of different stall scenarios, without elevator-pitch input, to indicate how the airplane "wants" to fly, and its descending response in each situation. These will show that the aircraft will not stall without pilot input, because there is no change to the set elevator-pitch, even with large power change.

In this scenario, power reduction below sustaining power would cause some reduced elevator-pitch effect allowing acceleration. There would be no stall.

A second demonstration of each scenario follows, using the elevator “aft/to” control input for learning indications of approaching a stall, and then, a third demonstration of an actual stall.

Emphasize minimum altitude loss and recovery techniques throughout all demonstrations and practice.

Emphasis is to understand, for an airplane to stall, it requires the pilot pulling on the elevator control, and initial stall recovery is release or push on the elevator control.

In all different configurations, with ongoing discussion during the maneuvers, note the indicated-air speed at which a stall occurs and the altitude loss in the recovery, these become limitations for operation of this aircraft.

You must be convinced that stalling an aircraft is the result of improper pilot input causing some minimum indicated-air speed, at which stall will occur.

The most common, unwanted stall incidents occur unexpectedly at low altitudes. Often these incidents are at such low altitudes there is minimum altitude for recovery.

Stalls can only happen, when you pull on the control wheel or stick, in an attempt to “make” the airplane perform. Physically, it is impossible for the machine to do something it cannot and will always respond with descent.

In beginning flight, accomplish all maneuvers, except landing roundout and flare, with minimum use of elevator-pitch control. Initial flight demonstration and practice finds the limits of normal flight. That is, the maximum attitudes the aircraft can fly without any elevator-pitch input allowing change of indicated-air speed. You will find that when exceeding any of these maneuvering limits, it results in the aircraft descending.

Discuss and demonstrate the lowering of the nose and application of power at low altitudes, with approaches to actual landings. This allows acquaintance with the sight picture of low-altitude maneuvering. Demonstrate flight, seeing the ground, and obstacles on the ground, up close while maneuvering!

This exercise should be demonstrated by the Instructor, and be related to recognizing control feel of marginal maneuvering situations and initiating proper recoveries prior to even approaching close to a stall.

You should become aware of the control inputs and indicated-air speed at which beginning to feel stall indication for each maneuver. The

different attitudes and configurations have their own indicated-airspeed limitations for flight.

You should then be shown and practice how control input can cause the actual stall to occur. Emphasize that most recoveries will result in loss of altitude.

You must also understand that each aircraft has its own minimum indicated-airspeed at the different attitudes and configurations at which they will begin descending. Awareness of these indicated-airspeeds should be part of a normal checkout when operating any given aircraft.

The emphasis should be in awareness of control feel at minimum indicated-airspeed for a current configuration and attitude. The control feel awareness should cause recovery initiation well before reducing to stall indicated-airspeed. This relates to every aircraft checkout you fly.

The reference you have for indicated-airspeed is the reduced feel of control input and the indicated-airspeed indicator. Your airplane performance should relate to what you read on the indicator in spite of any theoretical errors that may be involved.

When determining the indicated-airspeed limits from actual operation, the pilot can use those actual limits as reference for control.

At any given maneuvered attitude and indicated-airspeed, there is an expected response. The pilot should know what the indicated-airspeed for the indicator installed on this aircraft will be for each attitude and always expect to fly well above the actual minimum.

Stall Recovery

“You Stall the Airplane!” “Turn it loose!”

Teach and drill the stall recovery as an emergency, minimum altitude loss, procedure. Most actual stall scenarios occur at very low altitudes, so use very rapid and positive recovery procedures.

When an airplane stalls use the rudder and little or no aileron to maintain controlled flight. The aerodynamic forces will attempt return to coordinated flight.

If the plane stalls and rolls, use down elevator and aileron turned *with* the roll to help the plane get into laminar flow flight, which should regain controlled flight.

Incorporate flight toward zero “g” in practice when learning how to recover from any low altitude unusual attitude, or stalled condition to attempt absolute minimum loss of altitude.

As part of finding limitations and recovery from extreme attitudes, you should practice the feeling of approaching a zero-g condition. This is rapidly pushing the nose down for momentary reduced g-force. This

maneuver results in less than one-g conditions, causing you to feel lifted upward against your seat belt.

These sensations are not usual and need to be part of normal recovery training experience from extreme attitudes. Flight at less than one-g reduces the aircraft wing loading and the related stalling indicated-airspeed.

Stall recovery is simultaneous nose down (release of undesired elevator-pitch input), wings level with horizon (for maximum vertical lift component), and then added power (for increased lift).

This quickly regains flying indicated-airspeed and required lift. In low powered aircraft, there can be a significant loss of altitude, during a full stall recovery. High-powered airplanes can often fly themselves out of a stall, without much if any loss of altitude, when releasing the extreme elevator-pitch input.

Historically, most inadvertent stalls occur at low altitudes. Thorough practice and drill of stall avoidance, and understanding of them being “Pilot induced”, should eliminate most of the potential for stalls.

These scenarios, occurring at low altitudes, are not the time to lose altitude, or learning what it takes to make the maneuver. It may be desirable, or required, to “immediately push the elevator-pitch control toward a momentary near zero-g attitude”. This will allow the wings to react with momentary reduced “g” loading, while doing the normal wings level, power and indicated-airspeed increase, stall recovery.

In any extreme situation, the airplane will probably lose altitude. At low altitudes, the best recovery may be that if there is ground contact, it may at least be with the wheels first rather than a stalled wingtip!

On a base to final approach turn, if a wing has stalled, it is unlikely, though possible, that recovery to minimize the altitude loss can be fast enough to avoid ground contact.

All pilots should practice stalls at a safe altitude to learn the probable altitude loss to be expected, and to know how their airplane may react. This turn to final should be high enough to allow stall recovery if needed. In all stall situations, it is necessary to reverse any aft elevator-pitch control and push, at least momentarily, while simultaneously adding power and leveling the wings!

High-Altitude Stall High-Speed Recovery

Operation at very high altitudes often results in minimum indicated-airspeed spread between mach buffet and stall. This then requires pilots to maintain special awareness of flight conditions that may cause undesired change to the indicated-airspeed.

Typical conditions that can occur are mountain wave action and possible vertical winds in the vicinity of thunderstorms. These

situations can cause considerable change in indicated-airspeeds. Modern aircraft autopilot thrust controls often hide these conditions so require close pilot attention.

In the event of stall at these high altitudes, stall recovery requires immediate release of any aft elevator or autopilot input to allow increasing indicated-airspeed.

It is normal in slower indicated-airspeed flight that the elevator trim is set to maintain a higher angle-of-attack. This requires positive pilot input, pushing the elevator control, to assure reduction of angle-of-attack.

If not attaining immediate stall recovery, delay at the reduced density of very high altitude affects the time and altitude loss required. It may be a minimum loss of fifteen hundred to three thousand feet, and possibly much more, with the related time, possibly minutes, for this change to occur.

An aircraft falling in the stalled condition can only happen with the aircraft manually held in the stall by a confused crewmember. With the acceleration of gravity being thrust equivalent to the gross weight and not allowed to reduce below critical angle-of-attack, the aircraft will quickly accelerate through the rarefied air into a high-velocity stalled descent.

—HIGH ALTITUDE, HIGH-SPEED STALL RECOVERY —

TRACTOR ENGINE MOUNTING OFFSET FROM CENTERLINE

Aircraft falling while held in stalled condition

High Speed pressure approx. 4 lb./ sq. in. (at 300 IAS) 100" dia.= 7800 sq. in. @ 4#/ sq. in.= 31,500 #. Idle power thrust approx. 4,000 lb. ram pressure approx. 27,500 each engine= 55,000 #.

55,000 # x 10 ft. = 550,000 ft. lbs. nose down pitch. Elevator @ approx. 100 ft. moment arm must have negative lift of 5500 additional loading to offset the drag pitching the nose down. In the stall condition with continuous aft elevator control or trim input, there is no way to recover without adding power.

Add Power to recover. At 12-degree Angle-of-Attack or greater in stalled condition, .2 (sine 12-degree = .2) causes thrust component-lift.

This added power with thrust component-lifting will aid pitching the nose up while reducing and eliminating the ram effect.

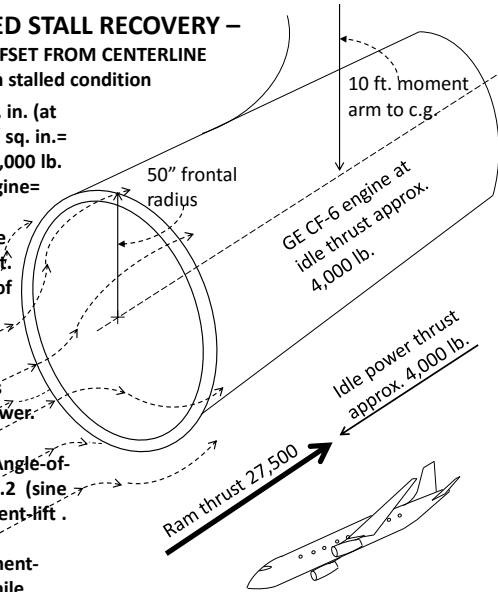



Fig. 8-1

If this happens with reduced power, the ram effect into under-slung engine frontal areas from the increasing mass of lower altitudes can create large nose-down pitch forces.

Recovery may then only occur with added engine thrust to reduce or eliminate the ram effect while simultaneously causing thrust component-lift, pitching up, at the engines.

There will now be that portion of thrust component-lift again contributing to angle-of-attack for a new indicated-airspeed as called for by the elevator position. This procedure requires coordination with nose-down elevator pitch, elevator trim, and increased power.

In all cases, at higher altitudes with the low-density air, this takes time and altitude. Stall incidents with delayed initiation for recovery can take up to twenty or more thousand feet. 

Chapter 9-----EMERGENCY LANDINGS

Emergency landings become necessary when losing engine power, imminent failure from loss of oil pressure, and precautionary for other reasons such as fire.

When the engine quits, immediate landing is the only choice. Precautionary landings may not create quite as much concern but require the same cautions.

A very large percentage of emergency off field landings have resulted in touch down beyond a point down one-half the length of the chosen landing area, with many fatalities from overrunning the chosen landing site itself.

This chapter discusses considerations and necessary procedures to make off-field landings for any reason.

Acceptance

A mental problem occurs in an engine-out situation. The first thing the pilot must do is understand; there is no decision, a landing is going to occur somewhere nearby. Acceptance in the mind is vital for continued decision-making. You can think about it a bit and make up your mind right now, so if it ever happens, the previous consideration of this kind of decision aids forward thinking.

Excessive controlling, especially manual aft elevator-pitch (pulling up), will not cure any alarm, concern, or fear of a flight situation. If the engine power available will not lift the aircraft sufficiently, it is going to descend.

- If the ground is close, with complete or partial power loss, controlling direction to a best probable landing site is likely your only option. Accept it! Keep flight control throughout; find a glide indicated-airspeed and land the aircraft.
- Prepare yourself mentally for this kind event by visualizing different kinds of scenarios. If the situation ever arises, it will come back to mind.

Select a Site

Accept that the airplane must land immediately and select a site. Upon the realization of engine failure, with or without acceptance of the necessity of landing immediately, the pilot must select a most suitable place for landing.

This is not something allowing delay or even considered contemplation. There often will be only seconds, though in many cases, it can be minutes, before the aircraft lands.

Low-level engine failure leaves few choices for a landing area. Prior consideration of the kinds of surfaces that could be available and the probable scenario of landing touchdown and roll-out conditions with low altitude engine failure aids in making the immediate analysis and landing decision.

Control the Aircraft

After selecting a landing site, reducing to maximum endurance (V_{me}) allows more time for the approach while reducing toward a minimum approach indicated-airspeed. This is typically a 10-15 knot indicated-airspeed reduction.

V_{me} (loiter) can be attained by multiplying best glide indicated-airspeed by .75, and V_c (optimum cruise) for most operations is attained by dividing best glide by .75. (V_{bg} divided by .75 equals 1.3 times V_{bg})

The Approach

It is now necessary to fly to the chosen field while attempting to setup and maintain approach and landing procedures as close to normal as possible.

Once the landing site is determined to be close, consider reducing the indicated-airspeed toward maximum endurance (V_{me}). This is a reduction of ten-fifteen knots below your best-glide indicated-airspeed. V_{me} (loiter) allows maximum time in the air while giving the opportunity to push the nose down toward best glide indicated-airspeed if the sighted landing area is moving up indicating going low and needing to extend the approach. Best glide and ground effect are ways to extend the approach glide.

If the landing area is moving down relative the windshield, you are going high so forward-slipping and/or increased flap will add drag for increased descent rate without increased indicated-airspeed.

The emergency landing approach procedure is similar to an idle-power approach. You are a glider. There is no engine control of altitude. A pilot must be proficient in energy management for minimum powered visual approach and Directed-Course spot landing procedures.

Initial control must be with consideration of the potential energy available, the need for zoom, if there is excess indicated-airspeed to attain a V_y for distance, or continued zoom/dive energy manipulation for turning. If low and slow immediate dive (descent) to maintain the flight control with whatever maneuvering is possible. In all cases, the elevator now controls the indicated-airspeed for rate of descent. Trim the elevator for a gliding indicated-airspeed; do not stall.

The engine out approach is initially flown by attempting to maneuver the aircraft toward a landing position as close to a normal approach as possible. This is flying toward a “key” position.

A “key” position is any point along a visual landing pattern reached in attempting to set up a normal approach position relative to the chosen landing site. If not high enough to glide to a downwind “key” position, then fly to a normal base to final “key” position. If still not high enough, then fly directly toward the landing point maintaining it visually sighted low on the windshield.

Fly the idle-power approach technique toward a highest “key” position possible for the selected landing site, while attempting restart, and radioing the status of airplane.

Do as many procedures, including re-start as possible in the time available while flying toward this approach “key” position. Accomplishment of a more normal approach and landing procedure will follow. However, never allow procedures to distract from positive aircraft indicated-airspeed control.

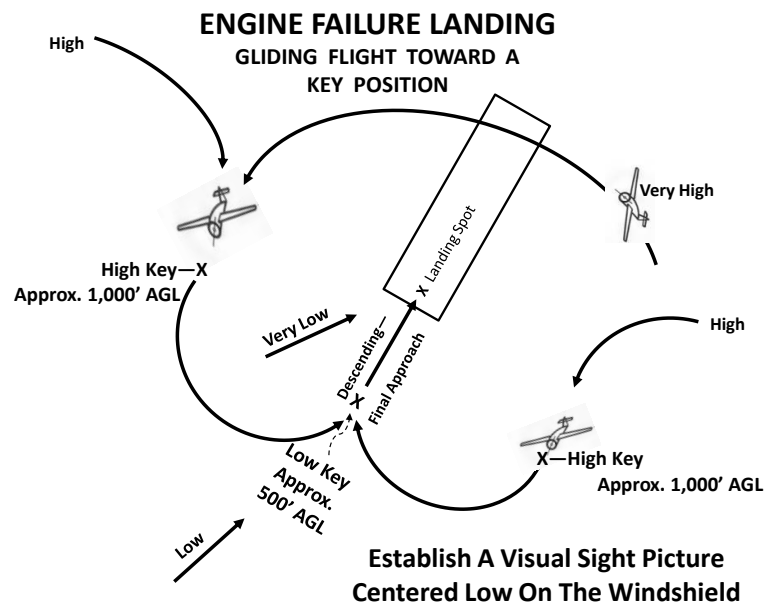

Fig: 9-1

Engine failure at very low altitude may force landing within a few seconds. At that point, you are already on short final, or even at roundout, or flare. This is a time for maintaining short-field and soft-field touchdown attitude and indicated-airspeed procedures.

Continue controlling to make a normal landing at a reduced indicated-airspeed approach allowing flaring for minimum speed touchdown, even if the touchdown will be into rocks, trees, cars, or houses. Direct the aircraft with rudder steering and aileron turning as able.

Maintain the approach indicated-airspeed. DO NOT PULL THE ELEVATOR CONTROL until roundout—DO NOT ALLOW THE AIRCRAFT TO STALL!—this is a normal idle-power type landing.

Preparation for Off-field Landing

Maneuver the aircraft as closely as possible to an idle-power approach procedure. If there is time, the pilot must be preparing for a probable crash scenario. Prepare the passengers for a crash and instruct them on protective measures.

Instruct the passengers to lean forward, cover their faces with arms, hands, and any shock absorbent materials available. Use anything available, clothing, blankets, to absorb the momentum of the head thrown forward during rapid deceleration, and for protection from impacted debris.

As the pilot, you must also try to prepare for the probable rapid deceleration that will occur on an unprepared surface.

The mental preparation is that, at some point at or soon after touchdown, everyone will become passengers. It is imperative that you be conscious when the aircraft stops!

The Mental Anxiety

A pilot making an actual engine-out approach to a selected area may begin realizing the aircraft could land short. It is almost impossible to convince oneself not to fly a little high or a little fast on an emergency power-off approach. Real-life experiences show it is usual for pilots to do one or the other and often both, staying high and fast.

This is a decision a pilot must have made prior to flight. It is essential to review, study, and consider how one will think when in the engine-out situation. How will the engine-out approach affect oneself mentally?

It takes an aware pilot to keep flying a normal approach in these conditions. Clear understanding of power off and idle-power approach and landing procedures is required. Minimum power landing proficiency and understanding use of ground-effect helps in the decision not to fly too high or too fast.

Directed-Course visual acquisition for flight toward the landing area is primary for control.

Remember; the accident occurs at or after touchdown. Until then, fly your airplane.

What is Experience?

Off-field landing experience comes from considering scenarios of possible conditions. It is possible to project an infinite number of

scenarios, from farm fields, with little or no obstruction, to landing in houses, rocks, trees, and gullies. At least there has now been consideration of what could happen.

You will try to touchdown, with controlled minimum forward velocity. The landing gear, which is stressed for landing, should be first to absorb energy. Trees or other obstacles encountered with the wings can contribute to stopping.

The cockpit is least designed for absorbing energy and makes it a hazardous place if encountering an obstacle. Think about the difference, landing on top of a tree or between trees. Steer as possible to avoid any direct impact with obstacles. A glancing impact is preferable.

A common off-field landing situation is the nose-wheel catching and flipping the aircraft upside down. Now you are hanging by your seat belt. What does that feel like? Think about it. Hanging upside down, at night, with a broken arm, what do you have to do now?

Engine failure on a dark black night with no landing light available and unable to distinguish anything on the ground is an interesting condition. The landing is inevitable. Set a minimum forward indicated-air speed, by configuring with full flaps and full nose up elevator-pitch trim.

The configuration of the aircraft will cause higher vertical descent, with a minimum forward velocity. This may also be a viable option for landing in treetops or on top of a building.

There will be no stall if aft elevator-pitch is not manually applied. Maintain the wings level, while bracing for impact. Initiate protection of the face early since there is no way to know when impact will occur. Remember landing lights may be a way to alleviate this kind of situation.

Upon eventual touchdown, the landing gear absorbs the vertical impact, and much of the forward speed, minimizing the stopping distance.

Consider that deceleration from forward velocity is more gradual than the instant stop of vertical descent at surface contact.

See, you just gained a little experience. There are lots more scenarios that could be thought up. All this thinking is gaining experience.

In any case, prior consideration is the key. If you considered it five years ago, it is still there when the time comes to use it. Practice this at a safe altitude to see if any specific control is required and learn the descent rates that result.

Technique

In gaining your experiences by considering all these scenarios, you might also talk to some of the old pilots of the world. There are those that have done this thing for real and all have considered it in some manner.

A technique might be having the elevator-trim full nose up at touchdown. That reduces the elevator-pitch input pressures quite a bit. You might have to hold the nose down some as it slows.

It is better sinking than stalling. Stall is falling. That is when people tend to get hurt badly. The aircraft structure can absorb sinking much better than catching a wing from a stall.

Practice of techniques at altitude enable having mental preparation and a procedure ready. Low altitude power loss at take-off is not the time for innovation or invention.

Always know a minimum indicated-airspeed for your aircraft.

Landing vs. Crashing

A common phrase that appears in many accident reports says, “The aircraft stalled and crashed!”

The emergency off-field landing situation seems to infer a crash if damaging the airplane and a landing if not damaged. However, there is a difference between landing and crashing which does not involve the condition of the airplane.

The control of the aircraft during any approach and touchdown determines the difference of landing or crashing. A controlled aircraft flown to and through touchdown is a landing. An approach, which stalls the aircraft at any time prior to touchdown, will result in a crash. A crash is the aircraft falling uncontrolled to the surface, even just a few feet.

If making an emergency off-field approach to an area with obstacles there is a strong tendency to try to make the aircraft avoid these obstacles.

Often it is not possible to avoid these kinds of obstacles in partial or unpowered forced landings. You must accept that it is going to be bad and continue flying the aircraft to a normal landing approach and touchdown, no matter the condition of the landing area.

The landing gear is the obvious first place you want contact with the surface. Its design is to absorb lots of energy. After the gear, the wings contacting obstacles will absorb some energy. The fuselage should be the last place you want to encounter an obstacle. You are there. A direct encounter with an obstacle can push the engine back into the cockpit. That is not good. A glancing encounter may be better.

The key is to use all means possible to slow with minimum contact of the fuselage. This means you must have controlled the aircraft as long as possible. At touchdown, you will quickly become aware when you no longer have any control and have become a passenger.

Continuing the Approach

You have now gained enough experience to be aware you definitely want to land on that chosen area or at least close.

You will visually establish a Directed-Course on the final approach. Now you are confident you can make the field. The field sure looks bad. There are trees and rocks just short of the touchdown point, and the field looks rough down this low to the ground. It looked a lot better from a higher altitude. The tall grass was covering up a lot of rocks, ditches, and gullies.

You have to live with the decision. In some cases, if recognized early enough, it may be possible to change landing fields. That is another decision that deserves consideration when discussing scenarios. Be real sure, if you decide to change landing fields.

Landing

Now you have to land this thing on the selected area. Get it centered low and unmoving relative to the windshield. Attaining a Directed-Course allows early confirmation of the landing area and enables more time for controlling. If maintaining a Directed-Course, you cannot miss.

Consider if it is necessary to land on the area at slightly faster indicated-air speed, or can you afford floating past some. Are you faster or slower than best glide indicated-air speed? Keep the visual picture. Make the airplane go to it.

You better watch out when trying to make the airplane do something. Maybe it can't. Be real careful using the elevator-pitch control now. You have the indicated-air speed set with elevator-trim. All you can do with the elevator-pitch, before roundout and flare, is pull too much and stall. Don't do that!

Extreme Landing Surface

If landing on an extremely bad surface, it is obvious dismantling of the aircraft will follow. Consider using maximum nose up trim and full flaps for a minimum forward velocity as outlined for the dark night landing. Then you don't need the elevator-pitch control. The aircraft will be at its minimum indicated-air speed, a behind the power curve situation.

The descent rate will be some higher and any change will require pushing the control wheel. That allows the landing gear to absorb its maximum of both vertical (potential) and horizontal (kinetic) energies.

Remember, there is no set way to make these rough field obstacle landings. You must have previously considered as many different scenarios as possible. Never decide there is one way to do this.

When the time comes, you must do whatever it takes for that situation. It will not be any of those previously considered. Every landing approach is the same; the touchdown will be different in different circumstances and with different obstacles. Land the aircraft first, don't let it stall.

Landing on Relatively Smooth Surface

On relative good surfaces, you can set the indicated-air-speed for a normal approach to a short field or soft-field landing. Set the elevator-pitch trim to this speed in anticipation of making a normal touchdown.

Now, are you high or low? Most people tend to be high. You can utilize drag procedures like extension of the flaps or slips to increase descent.

Are you low? You could be some low, though with care, keeping the landing area centered on the windshield it should not be too low. You are below best glide indicated-air-speed; push it down to get best glide indicated-air-speed again. That will extend the glide. If you are making the approach with full flaps for drag, raising some partial flaps will extend the glide distance.

Do you feel you are too low for that? You have little choice but to push the elevator-pitch control to gain best glide indicated-air-speed, or even a little faster, and level just above the surface, with minimum flaps for reduced drag. Now you will be in ground-effect. That can extend your glide distance even more.

Maneuver to a minimum forward speed. You are just above the ground, hopefully, approaching the selected touchdown area. You are landing...wait a minute! This technique is the same for all landings. Your approach to touchdown is always the same. It is just another Visual Directed-Course toward a landing area. This is what you always do when making any idle-power approach...isn't that interesting?

Touchdown

The roundout and flare will likely be the last control inputs you can make, unless you are on a relatively smooth field. At this point, whatever it takes. Keep flying through touchdown. You will recognize when you have become a passenger, until then, keep flying, and keep steering.

The roundout has leveled the aircraft, and it is slowing and sinking. Continue to flare the nose up as normal. Just don't stall. Any stall should occur only at touchdown.

You have maneuvered to a minimum forward speed. That is the best you can do. Do not try to make it fly slower. It can't. It will stall if you attempt it.

You are on the ground. It is rough. You never experienced anything like this before. This part needs discussion.

You just landed in rocks and gullies. The airplane just came to a rapid stop.

Upon touchdown, you realized you had no control. You became a passenger. You even thought that.

"I am now a passenger—I have to be conscious when the aircraft stops."

It may seem strange, if this ever happens, but you will think that. Why?

Because I just told you so! It is now in your mind, and if the time ever comes, you will recall it...believe me, I know.

Landing Roll

Did I say roll, well, maybe so, maybe no? You are not finished yet. Most of the excitement takes place from touchdown to stop. You thought the approach was tough, but the landing is where it is.

What do you do during the landing roll?

The main thing is, in what condition you need to be when the aircraft stops.

YOU NEED TO BE CONSCIOUS! If not conscious, you can do nothing for yourself or for others.

How do you do that? Well, you have to protect your head. Don't let it bang around. You just instructed your passengers to protect their heads and faces. You have to do the same, if you can.

Consideration of some techniques might help protect you during touchdown to stop. (I don't necessarily call it a landing roll.)

Survival

You can expect any emergency landing touchdown and rollout to be very exciting. Assume there will be obstacles of some sort that will cause rapid deceleration and probable dismantling of the aircraft. Therefore, at touchdown you must be prepared to survive this deceleration until stopped.

Staying Conscious

You just touched down on an unprepared field. Things are quickly going bad.

How quick is quick? How long from touchdown to stop, if you land in the trees, rocks, and gullies? If you encounter irregular hard objects, the airplane is going to start coming apart. It may tip over on its back. No one can guess. No two incidents are ever the same.

Everything takes time.

The one thing you can depend upon is that the deceleration will be quite fast. In most cases, you could expect touchdown to stop within three to five seconds.

Time

During those few seconds of deceleration, you are to recognize you are a passenger and be protecting your head to assure consciousness when stopped. That is not a lot of time, but maybe it is enough to do something. How long is three to five seconds?

Try counting...one thousand one, one thousand two, one thousand three, one thousand four, one thousand five...! That is a lot of time.

What did you do during this time?

One thousand one...you had previously figured out how this works, so at touchdown in these extremely rough conditions, you quickly realized you were now a passenger. You had no control of the aircraft.

Thrown forward from the rapid deceleration, you have leaned against the shoulder harness. You happened to have a coat you had previously put in your lap, put it up into your face, and wrapped your arms around your head to keep from banging against the glareshield and window post.

One thousand two...you are keeping your eyes open, so you can react. Things are bouncing all over. When is this thing going to stop?

One thousand three...It seems like it has been three minutes. It is like slow motion. I almost feel that I can do anything I want.

One thousand four...wow, it just flipped over on its back.

One thousand five...It finally stopped. I'm conscious, but I'm hanging upside down. I better get everyone out of here.

After Stopping

Anyway, you have stopped, upside down, hanging by your seatbelt, with a broken arm. Do you know what that feels like? Take time to consider this kind of situation as part of your experience training.

Don't worry. You are conscious, and if you get out quickly before the plane catches fire, you are home free. You will heal. Those bumps on your head will go away.

Ouch! That hurts, dropping from the seat belt onto your head. Your left arm isn't doing anything. You have to get these people out!

What do you think just happened?

You were protecting your head and face while watching what was going on. Your brain works fast. It seemed like minutes for the thing to stop. You were lucky enough to be conscious.

You will be able to remember in detail all these events the rest of your life. That is what happens when you have your eyes open during fast-moving events. It could be the same in a rolling car accident, a fall from a ladder, or any other fast-moving situation.

Time seems to slow down...if you are watching.

Your passengers are conscious too as they were not bumped so badly. They were protecting their faces with coats for padding; arms wrapped around their heads, and leaning forward at impact, so...get them out of the airplane. The door is blocked! Kick the window out with your feet.

That part is all over now. Take care of anyone hurt badly, then go sit together by a tree somewhere and try listening for the birds singing. It's nice and quiet now. The birds should begin singing soon.

This is a way of relaxing for control of shock. There is not anything pressing for now. Rescue will come sometime in the next few minutes or hours. Don't worry about food. It takes a few weeks to starve. Most people need to lose a pound or so anyway. Of course, you always carry water.

Flight into IMC and Visual Disorientation

Loss of visual reference can quickly lead to disorientation and uncontrolled flight. A pilot without instrument flight training is required to know procedures to maintain control if inadvertently flying into clouds or for any other reason losing visual reference.

Flight into clouds requires an immediate one-hundred and eighty degree turn to exit the conditions. In addition, flight in certain marginal weather conditions, especially at night, can cause temporary loss of visual references, requiring maintaining control with reference to instruments, perhaps for some extended time.

We have now learned when trimmed hands-off, aircraft essentially fly by themselves. If practiced as normal flight, safe control when encountering inadvertent IMC is by simply turning loose the control wheel, watching and believing the turn-and-bank or roll instrument. Push a rudder to attain and hold a standard rate turn for one minute, then reverse the rudder to attain and hold zero turn and fly out of the condition.

With practice, a pilot will quickly learn satisfactory control to fly safely back to visual conditions. Note; one minute seems like a long time during this maneuver!

When maneuvering in this manner, there will be some minimum descent while in the turn. If the encounter is weather related, a small descent often aids in exiting the conditions, however to assure terrain clearance, adding a small amount of power would maintain a level turn and if deemed necessary, even more power causing climb.

If losing visual reference in night VFR, again by turning loose of the control wheel and maintain zero turn on the turn-and-bank instrument, it is probable using excess thrust for climb will aid re-attaining distant lights or references. At the same time, climbing increases terrain clearance. The flight continues with reference to the turn-and-bank indicator for reversing direction and/or continued maneuvering.

For a pilot initially taught to always fly trimmed hands-off, this is continued normal flight. Hands-off elevator trimming and rudder steering also make nice stabilized approaches. Just use a coordinated power change for altitude control in straight and level or turning flight.

Take-off Load Shift

In the case of an aircraft takeoff having a rearward load shift resulting in approaching stall, a reduction of the large take-off thrust setting would cause significant reduction of angle-of-attack. Depending on the stabilizer/elevator lifting, and the extent of aft loading, may allow enough time and altitude for recovery, or at least possible controlled landing straight ahead.

It is not intuitive to reduce power at takeoff when encountering such a problem, so only with prior consideration is it likely a pilot would ever think of this when involved in an actual situation. Most modern aircraft have single engine thrust sufficient for continued flight. Always consider a significant reduction of thrust. 

Chapter 10-----LET'S GO FLY

This chapter is putting it all together. You are going on a flight to learn what a pilot can do.

What makes an aircraft fly? Money! How does an airplane fly?

Do not worry too much about how. Engineers designed your airplane to be aerodynamic and manufacturers built it to fly. It is a big chunk of aluminum sitting there. You cannot change that. You just deal with it. If started and turned loose, it will fly by itself.

What is all the fuss about? Your job, as the pilot, is the utilization of energy through thrust to enable safe, controlled flight.

What can a pilot do? Push and pull the throttle for power control and operate the flight controls...that's it! Let the machine fly hands off and control the engine thrust by pointing it in the direction you want to go.

This isn't about theory; it's just flying the airplane. Let's see if you really understand how to control an aircraft! Following are short summaries of the required control inputs for each phase of flight.

Study of Appendix-1 about the physiology of manual control prior to initial flight will help understanding how the body makes input to the controls.

Purpose

The initial flight of a Student is a big and lasting impression of how to control an aircraft. This makes it important to consider how to conduct this first flight. Demonstrating the following procedures to initial flight Students introduces the concept that the airplane flies, they direct. Use of hands-off flight control throughout this initial flight insures the new Student understands...the airplane wants to fly and left alone will fly.

Minimum control input throughout this flight, limited to power change and rudder steering, with the elevator trim set prior to takeoff, allows the initial Student to concentrate visually on learning to see, hear, and feel the aircraft response while controlling with rudder for steering.

Taxi for Takeoff

You start the engine and prepare to taxi. This is driving the aircraft on the surface. Acceleration is with the hand throttle, steering is pushing the rudder pedals, and stopping is with the individual foot operated brakes on the rudder pedals...there is blasting air blowing behind.

Initial Students often need shown the technique of "wiggling" the rudders to and fro for precise directional control until learning the "feel" of steering with the feet as explained in Appendix-1.

It is a new experience with a large machine. It is now twenty or more feet to each wing tip. You have to remember that, because it is you. You are real big now.

The tail swings in a large arc when turning and on some aircraft has an arc of travel larger than the wing tips. Think big!

This all requires visually checking for clearance of the machine and the taxiway before maneuvering the aircraft. Don't hesitate to vocalize when clearing. "Clear left", "Clear right", "Wingtips clear", "Clear behind".

Traffic on airports is one-way. There is no passing or meeting of opposite direction aircraft. If an aircraft is in the way, you just have to stay back and wait for it to clear. Other aircraft will do the same for you.

- Movement/motion control is with throttle input.
- Steering and braking are with the rudder pedals.
- Where are the wing tips?
- Don't forget the propeller-blasting air behind. It can blow things away, and other aircraft can blow you away.

Takeoff Flight

There are pre-takeoff procedures to assure proper configuration of the aircraft for takeoff and that the engine, instruments, and flight controls are functioning properly.

For initial flight control, there is a pre-takeoff setting for the elevator trim. This setting determines the indicated-airspeed at which the aircraft will lift-off; initial flight begins.

For this flight, we will set the elevator trim for an expected V_x as the initial indicated-airspeed.

You taxi onto the runway for takeoff. With most small aircraft, it is brake release and takeoff power set to maximum forward throttle. The aircraft begins accelerating down the runway using the rudder controls for steering alignment along the centerline of the runway.

The use of rudder only automatically corrects the engine turning effects. As the aircraft transits the indicated-airspeed set by elevator-trim, the aircraft will begin flying. It is now airborne.

For this first flight, steer with rudder input, aided with minimum control wheel aileron turning by the Instructor as may be required. Visually sighting a prominent point on or toward the horizon allows maintaining direction as you continue ahead in a slight nose-up climb attitude. You are climbing at the lift-off indicated-airspeed. There is

no more acceleration; you are in space with three-dimensional maneuvering capabilities.

Since setting takeoff power, there has been only pilot control input of steering with rudder and possibly some turning with aileron. Throughout all flight operations, coordinated power and elevator pitch input is always whatever it takes. Then trim toward hands-off control.

When airborne, the momentum of large (mass) aircraft, at their higher indicated-airspeeds, requires larger areas of operation and more time for attitude change. At higher altitudes (low-density air), the related true airspeed is a higher velocity within an air mass and requires even larger areas for operation.

Unless flying very close to the surface, there is little reference to indicate the extent of travel during a maneuver. Visual observation of low-level flight maneuvering allows learning judgment of the required space for close to the ground maneuvering. Higher altitude maneuvering requires little consideration of the extent of space involved.

- Elevator-pitch was trim-set for an initial indicated-airspeed, there has been little, or no input of elevator control.
- Steering is with rudder during ground roll and initial flight. Heading is toward a visually selected point in the distance toward the horizon.
- Control-wheel aileron if necessary for maintaining wings level or turning to maintain headings.
- Throttle setting is at maximum power for takeoff.
- Continued rudder input for headings and turns allows fixing its use in the Student's mind. The associated yaw allows learning awareness of kinesthetic feel of the airplane.

Climbing Flight

The maximum or takeoff power thrust is sustaining the flight with a climb-angle from excess thrust. The aircraft is now proceeding straight ahead in a climb attitude. You can monitor the sustained thrust and elevator-pitch trim as indicated-airspeed and the excess thrust and climb-angle as rate-of-climb.

Initiate any required change in climb indicated-airspeed with small elevator control input. Then adjust the elevator-pitch trimming to set the new indicated-airspeed for hands-off elevator controlling.

The visual picture is the horizon level across the lower edge of the windshield or even slightly below the nose cowling and for heading control a selected prominent point on or toward that distant horizon.

Throughout the climb, initiate small-banked clearing turns of 10-15 degrees left and right of the selected heading point. This is slow rudder steering input and visual attitude monitoring of the horizon with small-banked angles across the windshield while turning back and forth. This continues throughout all climbing and descending flight to allow scanning the area for conflicting traffic.

- Elevator control and elevator-pitch trim adjusted to attain a desired climb indicated-airspeed.
- Steering with rudder for small angled clearing turns during flight. Aileron input if necessary for turning to a heading.
- Throttle setting continues at maximum continuous power.
- Climb rate will be that available from excess power.
- Visual sighting of the horizon during climbing turns is at a continuously changing, small angle, low across the windshield.

Level Flight

Upon approaching the desired cruising altitude, begin gradual power reduction to cause leveling for a desired constant altitude.

If requiring a different cruise indicated-airspeed, the elevator control can be pushed slightly to *allow* acceleration, or pulled slightly to *allow* deceleration with coordinated power adjustment of thrust to *cause* the indicated-airspeed change. Coordination of power with elevator-pitch trim sets the desired indicated-airspeed for level flight.

The visual picture of the horizon will now be level across the windshield and in a desired direction as referenced to a chosen heading point on the horizon. Checking wing tips equal distance from the horizon confirms wings level while allowing scanning for traffic. When properly coordinated, the aircraft flies with hands-off the controls.

- Elevator control and elevator-pitch trim adjusted to set a cruise indicated-airspeed.
- Throttle setting coordinated to sustain level flight.
- Steering is with small angled turns by rudder input for heading corrections during flight.
- Aileron input for desired bank angle as necessary if turning.
- Visual sighted horizon fixed level across the windshield, directed to a distant point.

Turning Flight

Level constant indicated-airspeed turns use aileron and rudder input to maneuver into a bank-angled attitude in the direction desired. The rudder input steers the thrust to coordinate any adverse turning forces.

Coordinated power/thrust increase is necessary for altitude control as the aircraft rolls into an angled attitude. At the desired angle of bank (the horizon angled across the windshield and the aircraft nose moving level along the horizon), neutralize aileron input. The power increase coordinates the thrust component-lift (climb-pitch) to maintain the nose visually tracking level across the horizon.

Rudder input as necessary maintains turn coordination.

Choose a point on the horizon toward the new direction of flight, and as the nose tracking along the horizon approaches the point, the aileron and rudder coordinated input, are turned back to level the wings for flight direct toward that new point.

Level constant indicated-airspeed turns are limited in bank angle by the maximum power available. Steeper banked turns will require coordinated aft elevator pitch input with related slowing from increased angle-of-attack.

Reduction of power coordinated to maintain level flight, while reducing the turning bank angle, returns to the sustaining thrust setting as set prior to initiating the turn.

- Aileron turning during flight is coordinated with rudder steering.
- Aileron input as necessary to attain a desired angle of bank, then neutralized.
- Throttle setting coordinated with added thrust for climb-pitched lift to maintain level turning flight.
- Visual sighting confirms level nose tracking along the horizon.

Maximum Performance Turn (wing-over)

Initiate maximum performance zoom/dive turns with increased thrust to maximum, which will pitch the nose into a climb attitude. Simultaneously roll into the turn with increasing bank using coordinated rudder input into the turn, and as indicated-airspeed reduces, the nose begins dropping.

As the bank angle passes 45 degrees, not to exceed 60 degrees, and the nose descends toward the horizon, begin reducing thrust toward the previous sustaining thrust. The bank angle must be coordinated rolling out to wings level as the aircraft turns 180 degrees.

There is little or no elevator-pitch control necessary, so the angle-of-attack is then constant.

- Aileron turning during flight is coordinated with rudder steering.
- Aileron input as necessary to attain a desired angle of bank, then neutralized.
- Throttle setting coordinated with maximum thrust for climb-pitched lift to initiate the climbing/descending turn.
- Rudder insures nose down vertical pitch with continued coordination while rolling out of the turn.
- Initially the indicated-airspeed will slow and then begin rapidly increasing as the nose descends through the horizon.
- Thrust is coordinated to return to the sustaining thrust, as the wings become level and the aircraft returns to the original altitude.

Climb

To initiate climb from a set altitude, increase the thrust to a climb power setting. There will now be excess thrust causing a climb pitch with increasing altitude from the excess thrust component-forward in direction of motion.

The visual picture will be the horizon level and low across the windshield similar to the initial takeoff climb to altitude. The procedures are the same. Clearing turns while climbing and leveling at a new altitude are the same as the original leveling procedure.

Leveling from Climb

When approaching an assigned altitude, initiate a gradual, coordinated decrease of power until attaining the sustaining thrust for the set indicated-airspeed.

- Aileron turning during flight is coordinated with rudder steering.
- Aileron as necessary for any required angle of bank to attain or maintain the heading.
- Acceleration to a higher indicated-airspeed cruise requires allowing continued climb thrust for causing acceleration with reduced elevator-pitch then power reduction coordinated at the new indicated-airspeed.

Descent

Initiating a descent is with gradual decrease of thrust. The horizon sighted visually will be level but move slightly higher across the windshield. There will be some initial acceleration.

When reducing thrust from the sustaining thrust, there is a reduction of the small thrust component-lift contributing to angle-of-attack. This causes a decrease of angle-of-attack allowing some acceleration, so to

maintain the same constant indicated-airspeed it requires a small nose up elevator-pitch input and elevator retrim for hands-off control.

Leveling from Descent

Adding power from descent increases the thrust component-lift at the engine, again increasing angle-of-attack, and allowing some slowing. Coordination with elevator pitch and elevator trim is required to resume constant indicated-airspeed, level, hands-off flight.

- Leveling at a new altitude requires again coordinating elevator-pitch and trim with the increased power setting to continue at the same indicated-airspeed.
- All descending flight requires coordination of elevator-pitch and trim with any changed engine thrust component-lift for maintaining constant indicated-airspeed control.

Descending Flight to a Destination

To descend, turn toward a sighted destination. As the destination comes into view in the windshield, maintain level cruise heading and altitude until the destination gradually moves down becoming sighted, and centered toward the lower edge of the windshield.

At that time, reduce power slightly to cause the aircraft to descend maintaining the destination as an unmoving point at the lower edge of the windshield.

This is establishing a “Directed-Course” toward the landing airport. Adjust the power and elevator-pitch trim to maintain the destination, unmoving, in the lower center of the windshield at the desired descent indicated-airspeed.

The initial power reduction of thrust will allow a slight acceleration. Coordinated elevator-pitch trim and thrust adjustment will set a desired descending indicated-airspeed. This descent technique will have the aircraft at approximately one-thousand feet above the destination at one to two miles out.

When approaching the traffic pattern altitude, level with increased thrust while maneuvering onto the traffic pattern downwind leg. Configure the flaps, and adjust the elevator and elevator-pitch trim to the desired indicated-airspeed for the approach.

Make configuration changes with power and elevator-pitch trim adjustments as necessary for maintaining altitude and indicated-airspeed.

On or before the downwind leg, complete the landing approach checklist, and adjust the elevator-pitch trim to maintain the initial approach indicated-airspeed.

- Aileron turning during flight is coordinated with rudder steering.
- Elevator and elevator-pitch trim adjust to maintain the desired indicated-air-speed.
- Throttle setting adjusted to coordinate the sustaining thrust for any changed configuration and indicated-air-speed. Constant altitude is coordinated with thrust.

Approach

A normal landing approach will continue the downwind leg, past the approach end for 20-30 seconds, then, initiate a turn to base leg with some reduced thrust for a gradual descent, and a second turn to the final approach. Coordination of power then maintains a gradual descent to rollout of the turn on the final approach at approximately 500 to 700 feet above the ground.

Maneuver with turns, to align tracking over the extended centerline to the runway. Adjust the power to maintain altitude until the landing area visually centers again low on the windshield, then reduce thrust slightly to maintain the landing area in that fixed sighting.

Configure the final landing flaps and adjust elevator and elevator-pitch trim with coordinated power to the final approach indicated-air-speed.

Complete the final landing checklist while maintaining the landing area unmoving in its low, centered position on the windshield.

- Aileron turning during flight is coordinated with rudder steering.
- Elevator control and elevator-pitch trim set the final approach indicated-air-speed.
- Throttle setting adjusted to coordinate the approach descent to maintain the visual sight-picture of the runway landing area unmoving, centered low in the windshield.

Landing

When approaching the end of the runway, approximately 10-15 feet above the ground, begin gradual pulling of the elevator control to roundout, leveling the aircraft. This reduces descent rate and slowing of the indicated-air-speed. Simultaneously start power reduction toward idle, steering with rudder for main-wheel alignment with the runway and turning with aileron as necessary to maintain centerline alignment as sighted ahead.

The aircraft will be slowing and sinking toward the runway. Continue the aft elevator manual control, to cause and hold a slight nose up flaring attitude, while allowing slow sinking to the surface. Your peripheral vision will see the ground begin rising up alongside the airplane...hold that attitude...Touchdown!

Continue controlling with the flight controls as if flying. As the aircraft decelerates, reduce the aft elevator control to allow the nose-wheel to touchdown.

On the ground, nose-wheel steering and individual main wheel braking will be available for directional control, slowing, and stopping...the flight is complete...but you are not through, keep flying until parked.

Taxi to parking uses the same procedures and considerations as when departing. You are big again and must remember where the wingtips are relative to your aircraft, your blasting air, any crosswinds, and the environment in which you are maneuvering.

- Steer with rudder to align the fuselage with direction of movement. Turn with aileron to align tracking toward the landing area.
- Adjust the throttle setting to coordinate descent to maintain the visual sight picture of the landing area centered low and unmoving in the windshield.
- Reduce power toward idle or adjust as needed for control, use manual elevator control for landing roundout, and flare.
- Landing roll directional control is with rudder at touchdown
- At touchdown, turn the ailerons full toward any wind and immediately check brakes to assure availability.

Crosswind Landings

As you approach for landing, the prevailing crosswind requires a heading correction turned into this wind for maintaining tracking alignment over the runway extended centerline.

The visual picture shows the landing area unmoving near the bottom of the windshield, but offset to one side, away from the wind direction.

For this approach, you will use the technique of maneuvering into a sideslip prior to roundout. Input and hold rudder steering to align the aircraft's longitudinal axis parallel to the runway. Simultaneously input aileron control to turn toward the wind.

You hold this sideslipping maneuver until touchdown. This has the wheels aligned with the direction of motion down the runway for touchdown. The banked attitude into the wind is causing a horizontal force vector for offsetting the crosswind vector, and with aileron turning adjustment, maintains tracking over the runway centerline.

At touchdown, the main wheel toward the wind is lower so touches down first. Shortly the opposite main wheel touches down. You continue steering the rudder to maintain the centerline travel, and

turn the aileron control fully into the wind, to prevent possible wing lift from wind gusts, during the rollout.

As the aircraft slows, the relative-wind diminishes, so the crosswind will be trying to weathervane the aircraft, possibly making steering control difficult.

If steering seems marginal, you add some power to cause blasting air deflecting some of the crosswind force across the rudder aiding in steering. Use individual wheel braking to aid directional control.

As you slow the aircraft to turn off the runway and stop, you continually monitor the relative-wind direction, and adjust the ailerons and elevator, to avoid any wing or tail lifting.

Taxiing with strong winds requires much care. Offset of weathervaning effect may require propeller-blast, with coordinated braking for steering and speed control.

- Rudder steering coordinates turns toward the landing area, holds the direction of main wheel alignment when in the slip, and then controls the rollout and taxi directional control after touchdown.
- Aileron input as necessary for angle of bank when turning to headings. With the cross-controlled sideslip maneuver, a roll angle creates horizontal (side-to-side) control of tracking for opposing the crosswind effect.
- Slightly reduced throttle setting coordinates descent to maintain the sight picture, of the landing area, visually centered low in the windshield.
- Reduce power toward idle for landing, or maintain some power if required for propeller-blast, to counter crosswind during the landing, rollout, and taxi.
- Manual elevator-pitch control is required for the landing roundout leveling and flare.

Emergency Landings

You just lost your engine power! You are now a glider. The aircraft begins an immediate descent accelerating toward a new indicated-airspeed caused by loss of the vertical lift component of engine thrust.

You immediately adjust the elevator-pitch and trim to maintain the best-glide indicated-airspeed. Simultaneously, you look for a suitable landing area.

An open area looks suitable, so you turn toward it. Meanwhile, you have attempted engine re-start to no avail. You make an emergency radio transmission for alerting others of your problem and location.

Realizing being able to make the field, reduce ten-fifteen knots toward loiter indicated-air speed for your approach.

Your altitude seems low; you head directly toward the selected landing area while pushing elevator to increase back toward best glide indicated-air speed. Maneuvering, you place the landing area into an unmoving visual picture centered low on the windshield. It starts moving down on the windshield.

You know that means you are a little high so reduce back toward loiter and/or turn toward a base to final approach key position to lose some of the extra altitude. As the landing area begins rising, turn back to visually center it again.

You continue and again the landing area is moving down. You enter a forward slipping maneuver to cause increased descent rate while slowing toward loiter indicated-air speed. The landing area visually moves slowly back up to the lower windshield, and alignment is toward the selected landing area.

The landing site doesn't look very good down here at a lower altitude, but you are committed. You select landing flaps. That causes a lot of drag and the sighted landing area moves up on the windshield. Now you are going low.

You have trimmed the elevator to your minimum approach indicated-air speed but now must retract flaps to approach setting. That reduces some drag and reduces the rapid descent. The visual picture shows the landing area unmoving about the middle of the windshield.

The landing area is not moving relative to the windshield. You are going to make the field, even if you are some lower than a normal approach. You are at your normal initial approach configuration and indicated-air speed.

It looks like a rough field with some rocks hidden in the tall grass. This is not going to be pretty. You fly the aircraft toward the chosen area for a normal landing. Crossing the boundary, select full flaps and rotate for a normal roundout, flare, and touchdown.

Touchdown! It's rough, you no longer have control, and "you are now a passenger", you must be conscious when it stops. Protect your head...any way you can. Wrap your arms around it.

Anticipating deceleration and to avoid being thrown forward, lean forward against the shoulder harness while covering your head and face. If possible, keep your eyes open.

You are stopped; the airplane is upside down, and you are hanging from the seatbelt. You are conscious. Oh, that big bump on the head hurts, but it will heal. Get out and help any passengers as necessary. Go sit by

a tree, and listen for birds to start singing. Relax and enjoy the sights...you are alive.

- Rudder steering coordinates the turns toward a key point, the landing area, and directional control to touchdown.
- Aileron input as necessary for desired angle of bank when turning to headings.
- When making the field, elevator-pitch trimmed indicated-air speed allows the aircraft to fly between best glide and loiter indicated-air speed with minor manual elevator input.
- Flap extension and forward slips for controlling descent to maintain the landing area visually sighted as an unmoving target.
- Use manual elevator control for normal landing, roundout, and flare.
- If rollout becomes uncontrollable, you are now a passenger, protect your head to maintain consciousness.
- Exit the aircraft. Sit quietly for a while to control shock related to the excitement you just experienced.

Loss of Visual Conditions—180-degree Turn

Upon awareness of losing outside visual references, immediately turn loose of the control wheel. Look at the turn and bank or attitude indicator and with only rudder control, gradually turn to, and hold a standard rate turn as indicated on the turn indicator.

The aircraft will retain its angle of attack as set with elevator trim. With this small-banked attitude, the aircraft will slowly descend throughout the turn. After one minute, rudder-turn the aircraft back to indicate zero bank and fly back to visual conditions.

Throughout the maneuvering while lacking visual reference, you will experience some feelings of vertigo. Sit as still as possible with minimum head movement and believe the turn instrument.

As we have learned, the aircraft will maintain its indicated-air speed throughout. If conditions require, minimize loss of altitude with some added power throughout to maintain level flight or cause some climb.

If the loss of visibility is not weather related, such as dark night with temporary loss of ground reference, the same principal applies. In this case, continue the flight with rudder control and reference to the turn indicator to maintain level or maneuvering of the flight...believe the instrument! If unable to attain visual sighting with some climb, reverse course to regain visual conditions, minimize any control wheel input. The aircraft will fly fine with small power increase and rudder control inputs.

This is normal “hands-off” flight control but now with visual reference to an instrument.

- Turn loose of the control wheel. Do not immediately attempt turns.
- Look at the turn a bank instrument.
- With only rudder control, gradually turn the aircraft to indicate a standard rate turn and hold this for one minute.
- After one minute, reverse the turn to indicate wings level and fly out of the conditions.

So, How Are Airplanes Controlled?

It’s all throttle, control wheel (ailerons and elevator), elevator-pitch trim, and rudder pedals, for coordinated steering of thrust for a desired direction of motion...that’s it!

Engine power adjusted to a sustaining thrust and coordinated elevator-pitch trim causes constant indicated-airspeed, constant altitude travel (Hands-off Flight).

Adding Excess Thrust sets a climb pitch angle for increasing altitude or added lift in a turn. This changes direction of motion from horizontal to a climb angle with increasing altitude or in a turn, coordination by added thrust component-lift for constant altitude level turn.

Indicated-Airspeed Control:

The Elevator-pitch sets indicated-airspeed. That’s all the elevator ever does...change angle-of-attack. Normally, trimming the elevator or horizontal stabilizer maintains a desired angle-of-attack indicated-airspeed. Holding the control wheel manually for indicated-airspeed control is possible though for long periods can be tiring.

The vertical component of engine sustaining thrust contributes to aircraft angle-of-attack pitch. Any additional thrust beyond the sustaining thrust would be excess thrust and begin increased altitude.

Descent is with thrust reduced below level flight sustaining thrust. This causes descent-pitch with a small decrease of angle-of-attack and its related increased indicated-airspeed. Maintaining a fixed indicated-airspeed in descent requires re-trim of elevator-pitch when making any change of power setting below the sustaining thrust of a current angle-of-attack setting.

Acceleration and Deceleration:

Increasing or decreasing the angle-of-attack allows deceleration or acceleration.

For level flight, a newly trimmed angle-of-attack requires coordinated power to a new sustaining thrust setting for the changed indicated-airspeed.

The elevator-pitch change *allows* the indicated-airspeed to change. The coordinated power application *causes* the indicated-airspeed change.

Climb Control:

Adjustment of engine thrust to a setting greater than a given level flight sustaining thrust results in climb pitch with increasing altitude.

Directional Control:

The ailerons turn; banking for a turn causes a horizontal component of the aerodynamic and engine thrust component-lift forces. These horizontal component forces change the aircraft direction of travel.

The rudder steers; an aerodynamic yaw force (side-pitch) with rudder input directs the thrust to a desired direction for turn coordination and slip maneuvering. Additionally yaw makes a small change to wing lift and associated gradual banking.

Level, constant indicated-airspeed turns, require coordinated increased thrust component-lift to maintain the total vertical component-lift by coordinated power increase.

Descent Control:

Control of indicated-airspeed differs when reducing power settings below level flight sustaining thrust. A slight reduction of engine thrust below sustaining thrust will allow descent. Gravity component-thrust begins supplementing to maintain the sustaining thrust. There will be some acceleration with the reduction of that engine thrust component-lift contributing to angle-of-attack.

Flight control requirements change when operating with power between idle and level flight sustaining engine thrust at a set indicated-airspeed. In all reduced power descending flight, a power increase now continues to cause thrust component-lift increase but also increases the angle-of-attack allowing deceleration. Power decrease will reduce that lift with associated reduced angle-of-attack, allowing some acceleration.

Maneuvering in descent then requires coordination of elevator-pitch trim with any power change to maintain a constant indicated-airspeed.

Landing Control:

Adjustment of engine thrust, flap extension drag, and descent with controlled forward slipping, allows maintaining the sighted landing area, unmoving, as related to the windshield.

Elevator-pitch control is with manual aft input used for roundout and flare. The rudder steers for paralleling the fuselage to the extended centerline for short-final approach, touchdown, and landing roll. The ailerons turn side-to-side controlling alignment for tracking over the centerline of the runway until touchdown then turned fully into the wind. Wheel braking is applied as required for stopping and steering.

Ground operation; thrust for blasting air mass to supplement rudder authority if required for directional control in crosswind. Aileron and elevator control surfaces turned to counter crosswind effect.

All Flight:

For control of all flight, there are only those few things necessary for consideration. There are maximum indicated-air speed limitations for structural considerations and minimum indicated-air speed limitations for sustaining aerodynamic lift to allow safe, continued, flight. Therefore, there are maximum and minimum indicated-air speeds.

Just set the elevator-pitch for a safe indicated-air speed and it will stay at that air speed as long as you don't push or pull on the control wheel.

Power/thrust adjustment sustains the aircraft at its set indicated-air speed and with change allows climb, descent, or constant altitude control.

Increased thrust causes climb pitch with altitude increase. Decreased thrust causes negative climb-pitch, descent, with altitude decrease and allows gravity component-thrust to sustain the indicated-air speed.

The ailerons bank the attitude to cause a horizontal component of the aerodynamic and engine lifts that turns the aircraft. The rudder steers the direction of thrust for coordination of adverse forces in turns.

In a banked attitude, there are horizontal components of thrust causing turn, but for maintaining level turning flight, it requires an increased vertical component of lift from increased engine thrust component-lift to maintain constant altitude and indicated-air speed.

Steep turns may require elevator-pitch and slowing to maintain constant altitude. This requires caution when slowed as it may approach minimum safe indicated-air speed and stall.

About the only time you use any significant elevator control input, is during initiation of indicated-air speed trim change, and for landing roundout and flare. Most of the time you don't even touch the elevator control.

This is all there is. After all of this writing on why things happen, what can you do? You have no control of the aircraft design. You can only operate according to the basic physics involved, and the POH limitations of the structure. That's it...we've beaten it to death! Not quite one page double-spaced, but even you can fly! ➤



Appendix-1-----PHYSIOLOGY OF MANUAL FLIGHT CONTROL

From the 2014 March/April FAA Flight Safety-Brief

By

Gene Hudson

Gene is an Assistant Chief Flight Instructor at Trade Winds Aviation at Reid-Hillview Airport, San Jose, Calif. He has been a flight instructor since 1987 and has logged over 17,000 hours in over 100 aircraft types.

Stall

Year after year, stall/spin events account for a disturbing number of general aviation accidents. According to the Air Safety Institute's Nall Report, "failure to maintain airspeed" appears as a proximate or contributing cause in roughly 40 percent of the fatal accidents. This statistic persists in spite of stalls, stall recovery, and stall prevention having been taught – *ad nauseam* – to virtually every candidate for every certificate, rating, flight review, insurance checkout, and type certificate over the last half-century, or more.

Someone once defined insanity as "doing the same thing over and over and expecting a different result." It is the opinion of this author – a long-time flight instructor – that the results demonstrate that we in the flight instruction profession are not giving our customers an adequate methodology for dealing with this problem. Specifically, we do not provide a sufficiently clear and effective means of preventing unintentional stalls. This article is an attempt to define such a methodology.

Central to the problem of the prevention of unintentional stalls is a general misunderstanding of how and why an aircraft will stall. Too often, we hear discussed the aircraft's stall speed; in fact, the aircraft stalls if, and only if, the wing exceeds the critical angle of attack. That this will occur at a particular speed is only true given a closely defined set of conditions. Any stall speed is only valid at a particular combination of weight and load factor; the critical angle of attack does not change as long as the flap configuration is constant.

Trim

A second poorly understood concept is the issue of trim and stability. Pilots tend to think that the aircraft trims to an indicated-airspeed; this, also, is only true under particular circumstances. The static stability of an airplane tends to drive it back to a trimmed angle of attack. This will correspond to a particular airspeed only under steady-state conditions.

The stability of the aircraft can be used to the pilot's advantage with regard to stall prevention. In a nutshell, let go of the controls. Once releasing the controls, the aircraft will return to the trimmed angle of attack (regardless of the airspeed) within a little more than a second. Most aircraft will not trim to an angle of attack that exceeds the critical angle of attack; thus, with very rare exception, an aircraft loaded forward of the aft center of gravity limit cannot be stalled in hands-off flight.

Unintentional stalls, then, occur when the pilot applies enough backpressure on the yoke to overcome the natural stability of the aircraft, leave the trimmed angle of attack, and exceed the critical angle of attack. It would seem, then, that we could eliminate unintentional stalls by warning pilots to avoid applying excessive backpressure.

One would think this would work. History tells us, however, that it does not. Discovering the reason for this paradox requires bringing some outside knowledge into play. In particular, I find it helpful to consider the 19th century contributions of German anatomist and physiologist Ernst Heinrich Weber (1795-1878), and his student, physicist and philosopher Gustav Theodor Fechner (1801-1887).

Perception

These two scientists developed the theory of perception, defining the “just noticeable difference (JND),” or, in other words, the minimum change in a stimulus required to trigger perception.

With regard to pressure stimulus (such as force on the yoke), the JND is a change of approximately 14 percent of the pressure already present. Today, the relationships they defined are referred to as the Weber-Fechner law, or the W-F law. It is common knowledge in physiology but, unfortunately, not so well known in aviation.

Several features of the W-F law are important to flight operations. First, any stimulus (yoke pressure) which is constant will fade from perception over a short time. A pilot who is flying in an out-of-trim condition will soon lose the ability to perceive that he or she is applying any elevator pressure at all. The out-of-trim condition becomes the new zero; the pilot cannot trim it off, because they do not perceive that it is there.

Second, a constant stimulus (i.e., steady backpressure to compensate for being out-of-trim) will elevate the just-noticeable-difference. If the pilot is holding a constant 20 lbs. backpressure, the minimum pressure change he or she can feel on the yoke is now 2.8 lbs., in any direction.

Every attempt to make a “small” input will become a “small” input plus 2.8 lbs. of additional pressure that the pilot has no way to know he

or she is applying. The result is over-controlling; small, precise inputs are impossible.

Also, the pilot will tend to make unintended inputs, in pitch and roll, across a 5.6 lb. “dead spot” in his or her perception. This can be especially vexing when the pilot is attempting to accomplish non-flying tasks, such as reading a chart, or dialing a radio frequency; he or she will apply an unknown and unintended input up to the limits of the JND.

A pilot flying in this manner is much more at risk of inducing an unintentional stall. Too many pilots are in the habit of flying the aircraft with large control pressures, far away from the trimmed angle-of-attack. The elevated JND makes it easy to apply the control forces accidentally that are necessary to overcome the stability of the aircraft and drive it to and past the critical angle of attack.

Avoiding Stall

To avoid the unintentional stall, we need to develop the habit of flying the aircraft in trim and hands off. An airplane which is in trim and flown hands off is (with rare exception) impossible to stall. The natural (static) stability will drive it to and hold it at the trimmed (not stalling) angle of attack; flying hands-off ensures the pilot will not force the aircraft away from the trimmed (not stalling) condition.

Getting into a perfectly trimmed condition is not always as easy as it sounds. For most pilots, it requires a change in the way we touch the controls. Due to the physiology, it is virtually impossible for pilots to trim an aircraft precisely if their hands are still on the yoke.

Trimming, then, requires that we trim the aircraft to the limits of our perception (trim off the pressure), and then let go. Only with the hands off the yoke can we observe the change in pitch attitude and vertical speed, which is the clue to the remaining out-of-trim condition that existed below our ability to perceive.

Once observed, the change should prompt the pilot to pitch (with the yoke, not the trim) back to the desired pitch attitude and rate of climb, trim slightly against the error, and try again. Only when the aircraft will stay at the desired pitch attitude and vertical speed for five to 10 seconds in hands-off flight can it be considered to truly be in trim.

Once in trim, the pilot should endeavor to avoid violating that trim. That is, “if it ain’t broke, don’t fix it.” Said another way, the pilot should not touch the yoke unless there is presently an error in pitch that needs correction. If the airplane is doing what it should, there is no need to touch it!

All transitions in airspeed, power setting, and configuration will induce some trim change. Immediately address any change in the

trimmed condition to bring the aircraft back to the desired trim. Once regaining the trim, maintain it by flying hands off to the maximum possible extent.

It is important to realize that the oft-repeated advice “use a light grip” is, unfortunately, a misnomer. Another principle of physiology, the grab-and-grip reflex, makes this so.

Under stress, the reflex induces us to unconsciously grab hold (of the yoke) and grip with increasing pressure. Over time, the light grip will invariably escalate to the famed white knuckles condition we see so often, and create all of the same problems as an out-of-trim condition.

Thus, when a pilot does have to make a control input, it is important to avoid setting up a grip condition; it is better to touch the yoke, rather than to grip it. Use the minimum pressure required to achieve the desired correction, and then go back to hands off.

If you’ve developed the uneasy feeling that this methodology involves a radical change in the way we fly, you would be correct. It requires discipline, thought, and practice to achieve truly in-trim and hands-off flying skills, but the rewards are worth it: better stall resistance, smoother ride for the passengers, more precise control of the aircraft, and lower pilot workload.

#

My Comment:

There must be coordinated thrust change to attain and maintain a constant altitude with even small elevator trim change.

A tractor aircraft has lifting at the engine attachment that in descent causes elevator trim change with thrust change. In all realms of flight, pusher aircraft thrust change causes trim change.

Adding thrust for climb with a tractor aircraft may have some trim change due to increased prop-blast depending on the horizontal stabilizer position.



Appendix-2-----RECIPROCATING ENGINES

Most aircraft reciprocating engines operate without modern electronic or computer controlled inputs. You use manual control for starting and operation.

This discussion is about the basic considerations for engine operations. It requires understanding manual fuel/air mixture controlling for efficient burning.

Operating the Machine

Your airplane is merely a machine, powered by an engine. The operation of any machine requires understanding the ramifications of its use. There are limits of output, due to the power, structure, and operator abilities and capabilities.

You must continuously consider maintaining conservative care for the efficient utilization and physical use of any machine. As a serious operator, you should develop a sense of relationship, even emotion, toward the machine, similar to that of dealing with a person or animal. It is common for a pilot to talk to a machine, in a similar manner they would, if they were controlling an animal!

Highly automated automobiles today do not require much consideration of how they operate, but with airplanes, we have to understand their operation and limitations to a higher degree. It is just not acceptable to have a problem, when you cannot pull over and park to sort it out, or call a tow truck.

Flight Preparation

For every flight, you will inspect your aircraft, to assure it is safe and serviced. This requires taking time, doing interior and exterior preflight checks.

Perform your preflight inspections and checks as procedures. Walking around the airplane in the same manner, aids in learning an order of the inspection, so reduces the possibility of missing an item.

There are many items to look at, and when finished, a checklist to verify not overlooking or missing anything. In the beginning, it is best to carry the checklist, and read each item, until familiar with the machine.

Airplane Limitations

All airplanes have limitations. They are machines, and in addition to performance, there are costs to consider. Even the big airliners have the same limitations. Their designs all have similar considerations.

It is possible for airplanes to be powerful enough to go straight up, or fly in any attitude. Such airplanes are expensive and may only fulfill specific requirements of a given mission.

Your little airplane does not cost so much to operate so it makes it reasonable for the individual when learning. The airliner needs only to go safely and efficiently across the country while carrying a reasonable load. Both of these kinds of flight do not need the extra cost of super powerful engines or exceptionally strong structures. They may be limited in operation, but, with reasonable design considerations, they perform very well for their purpose.

There is a limit to what different airplanes can do. Some fly very slowly, and some real fast. The power available, when trying to fly attitudes pitched much above level flight, limits most aircraft.

All aircraft have structural limits. Design criteria optimize structural strengths with expected loads allowed.

Most airplanes have power enough only for attaining attitudes, 12-15 degrees nose up, and 40-50 degrees bank in level flight. What happens if you try to exceed an attitude limit? You descend!

Descending flight uses gravity component-thrust to sustain indicated-airspeed. If you attempt an attitude that is limited by the power available, the airplane will lose altitude due to gravity. The airplane will always continue moving according to the forces it encounters. If the engine cannot supply them, gravity will, but by descending at a new attitude.

The pressure of high indicated-airspeed flight and acceleration “g” loads, can stress the structure, so all airplanes have operational indicated-airspeed and load limits.

Exceptionally slow indicated-airspeed resulting in flight with increased induced drag greater than the thrust available will require loss of altitude to recover. Stalls also result from slow indicated-airspeeds by pilot over-control and may require maximum power and usually loss of altitude for recovery.

All flight has a limitation of power and structure. Your aircraft must always operate within the published limits as determined by the manufacturer. There are many other limitations due to flight regulation, traffic, weather conditions, flight over high terrain, and physiological limits of pilots and passengers.

Power System

Your engine is the source of operating power and is the only way to sustain flight, so deserves special attention and conservative operation to assure its reliability.

All airplanes have an engine as a power source to enable generation of lift. Safe operation requires dependable engines. For this reason, you must understand how an engine operates and how to care for it to maintain its reliability.

The most common engines used in small aircraft are four or six cylinder air-cooled reciprocating piston engines. These aircraft engines normally run at high power settings for long periods for takeoff and climb to altitude. Most flight is at a cruise setting in a range of 60% to 75% of maximum power.

This is not a discussion of procedures for specific engine operation since there are many different engines, fuel systems, and starting conditions. There are, however, certain fundamental requirements that apply to all reciprocating engines.

Ignition System

Aircraft engines have two independent engine driven magneto powered ignition systems. The ignition system does not rely on the aircraft electrical system.

The magnetos each provide high voltage current separately to one of the two spark plugs in each cylinder. This dual ignition system controlled from the cockpit by a multi-function switch, allows turning the magnetos on and off, or selecting either, or both. A malfunction of one magneto allows continued operation with one sparkplug in each cylinder. A malfunction of one sparkplug in a cylinder reduces that one cylinder to single sparkplug operation.

Engine Fuel Supply

There is an engine-driven fuel pump to assure a continuous positive fuel flow supply. Some airplanes also have an electric fuel pump for fuel transfer and backup for additional reliability.

There are two different ways of introducing fuel into engines. An engine with a carburetor creates low pressure through a venturi, sucking fuel into the induction airstream. An engine with fuel injection forcibly sprays fuel, under high pressure, through a small nozzle, to the intake valve area.

Fuel/Air Mixture

It always requires an optimum fuel-vapor/air ratio to ensure proper fuel burning for satisfactory engine operation.

High altitude, higher temperature, and/or higher humidity reduce air density, and limit the available oxygen for burning, resulting in reduced power possible. The fixed size fuel/air induction systems restrict available oxygen mass of less dense air so burn less fuel and so have reduced power in low-density air mass conditions.

Engine operation, for optimum power, is dependent on the complete burning of the fuel. As altitude increases, the lowered density of the air lowers the oxygen available so requires gradual reduction of fuel to maintain proper fuel/air ratio.

Manual adjustment of the mixture control actuator controls the fuel supplied to the air. You must manually maintain an optimum ratio of fuel and air throughout the flight.

You gradually pull the mixture control actuator, to coordinate with the reduced oxygen available for burning low-density air at high altitudes. This action results as if slowly closing the throttle, reducing the power output of the engine.

Adjusting the hand controlled manual mixture control changes the quantity of metered fuel at the carburetor, allowing proper burning for engine operation. The actual atmospheric condition within which the aircraft is operating determines the amount of control required.

Indication of the optimum ratio occurs when you attain the maximum rpm on fixed pitch propeller engine systems, or the maximum manifold pressure with variable pitched propeller engine systems at a current throttle setting

Carburetor

The carburetor is the device for metering and mixing of fuel and air for operation of your engine. It consists of a fuel metering venturi with a throttle valve (butterfly valve) for controlling the volume of airflow.

Fuel metered into the carburetor induction venturi, vaporizes by mixing with the air. The fuel then flows past the throttle valve, through the intake manifold induction tubes, to each cylinder intake valve, and into the combustion chambers.

Butterfly Valve

The butterfly valve controls the volume of airflow through the carburetor. The airflow volume in turn controls the quantity of fuel metered into the venturi area of the carburetor thereby controlling the power output of the engine.

At some altitude or power setting, the throttle, increased to full forward, will have the butterfly valve full open. After reaching that condition, retarding the mixture control sets and maintains the proper fuel/air vaporized mixture for optimum burning. After this time, power available slowly decreases as the air density reduces.

Mixture Control

At this point, any further reduction of air density will require reducing the fuel with the manually operated mixture control to maintain the proper fuel/air ratio. The continued reduction of fuel to the engine, in

this manner, results in a gradual loss of power possible with increased altitude.

Throttle

The hand throttle control connects directly to the carburetor butterfly valve. Forward/in manual operation opens the butterfly valve to allow increased air volume and fuel metering to increase engine power. Pulling the throttle full out closes the butterfly valve, reducing the fuel-vapor/airflow attaining an engine-idle operating position.

The throttle, pushed full in, causes the butterfly valve to be full open, and positions the induction system for its maximum volume of vaporized fuel/airflow into the engine.

Accelerator Pump

The accelerator pump is an integral part of the carburetor. Moving the throttle to its full-open position activates the accelerator pump, which inputs a small amount of fuel at the carburetor. This gives a momentary extra fuel input to allow rapid acceleration of engine power when running.

When you are cranking the engine, any time pushing the throttle full open, it inputs the same small amount of fuel. If the engine is not cranking, activating the throttle full open, multiple times (pumping), deposits a relatively large quantity of fuel, which will accumulate in the bottom of the carburetor.

A backfire during cranking can ignite accumulated fuel resulting in a carburetor fire. It is imperative you use caution, when using the accelerator pump as a source of starting fuel by activating it only when cranking so the fuel continually sucks into the combustion chambers. You must still be aware of the possible accumulation of fuel.

The cranking procedure for clearing flooded cylinders when starting does not necessarily eliminate all accumulated fuel in the bottom of the carburetor.

Carburetor Ice

Ice in the throat of a carburetor is the result of cooling by the expansion of the vaporizing fuel exiting the venturi. The accumulated ice is from vaporized fuel mixing with humid air passing through the carburetor. Icing occurs in engines equipped with carburetors similar to those installed in many light airplanes.

Carburetor icing occurs, from the expansion of the fuel and humid air exiting the carburetor venturi, which causes a significant temperature drop, so the water vapor may freeze. The ice forms at the outlet of the carburetor throat causing restriction to the fuel/air mixture flow.

If allowed to continue, the ice gradually restricting the airflow causes engine performance as if retarding the throttle. You will see a very slow reduction of engine rpm. Continued operation in this condition could lead to a complete blockage of the carburetor and engine failure.

Icing causes a gradual rpm drop, as though retarding the throttle, which, if not corrected, eventually causes the engine to run rough or quit. With a fixed-pitch propeller, when maneuvering, normal varying of the rpm often disguises icing effects.

Operation at idle settings for long periods is the most common condition for creating ice. This often occurs during low power descents and approaches to landings. Icing after engine run-up can also occur during waiting periods prior to takeoff

Conditions, conducive for carburetor ice, are temperatures ranging 15°F to 86°F (-10° to + 32°C). This is a large temperature span and relates to the extremes of humid conditions. Most aircraft procedures call for use of carburetor heat if conducting prolonged operation, at low to idle power settings.

The two situations for detection of the development of carburetor ice, a gradual drop in RPM with fixed-pitch prop aircraft, or as a gradual drop in manifold pressure with a constant-speed propeller.

A pressure carburetor inputs fuel past the throttle plate from the air inlet. Fuel-injected engine fuel/air mixture metering is into the intake valve area of the hot cylinder. This reduces the potential for forming carburetor ice.

When icing conditions exist, apply carburetor heat often at cruise throttle setting. At any indication of carburetor ice, always apply full carburetor heat. The engine may run roughly, as the ice melts and the water goes through the hot cylinders.

Carburetor heat should be full heat or nothing. Use partial carburetor heat only on aircraft equipped with a carburetor temperature gauge or ice light. It is good practice to use carburetor heat anytime operating at reduced power, especially for low altitude operation and landing.

If conditions are conducive to icing, or if noting icing during engine run-up, perform a carburetor heat check immediately before takeoff.

Carburetor Heat

Selecting carburetor heat directs an alternate source of air for burning. The alternate air source bypasses the air filter and directs the airflow to pass either near the hot engine, or near the hot exhaust system, to allow warming.

This warmer air is what melts any ice present. Warmer air also is less dense, so there is an associated small drop in rpm, as related to the normal power and air source.

When selecting carburetor heat, the warmed carburetor air, bypassing the air filter, introduces hot, less dense air, to the carburetor, enriching the fuel/air mixture. The warm air melts the ice from the carburetor venturi throat and throttle butterfly plate.

There may be some increased roughness for a few seconds as the engine ingests water from any melting ice, then after any ingestion, smooth operation within a few more seconds. Sucking some ice into the engine could occur, so there could be momentary rough, and perhaps backfiring, of the engine. After turning the heat off, rpm goes back to normal.

If there is immediate improvement, this usually indicates that either the richer mixture, or the bypassed intake, indicate the problem. If the engine smoothes out immediately with application of carburetor heat, then back to roughness when turning the heat off, indicates a blocked air intake filter.

Oil Temperature and Pressure

All engines require sufficient lubrication to minimize wear and prolong reliability. In addition to numerous rotating bearing surfaces. Reciprocating engines have many surfaces that slide across each other, so it is extremely critical, that sufficient oil is available for this purpose. The pistons, camshafts, and push rods are examples of components that have continuous moving contact.

The oil pump design provides pressure to assure all engine bearings and surfaces be adequately lubricated. Constant pressurized oil flow routed through orifices to bearings and bearing surfaces, splashed by oil bath, and sprayed onto the moving crankshaft, piston, and cylinder surface areas, provides engine lubrication.

Gauges located in the cockpit allow monitoring of oil pressure and temperature.

The lubrication process also requires maintaining oil within specified temperature ranges, high enough to assure evaporation of any possible water accumulation, and yet low enough to not breakdown its chemical characteristics. The oil temperature gauge allows monitoring this operational range.

One of the most serious problems you can encounter with an engine is loss of oil or failure of the oil pump. Lack of lubrication is disastrous to an engine. Though quite rare, it does happen. Loss of oil will rapidly lead to a high oil temperature and low oil pressure.

Failure of the oil pump or oil quantity, indicated by loss of oil pressure, will quickly cause a rapid rise of oil temperature. Though the engine may still be running, you can expect imminent engine failure.

If a landing area is immediately available, it may be appropriate to consider shutting the engine off to reduce its damage, but only if absolutely sure of the landing area. It then becomes an engine out emergency landing without having to consider imminent failure and changing procedures in the midst of an approach.

Whatever the case, it requires you make an immediate emergency landing. Whether or not the engine is still running, you should fly an engine out procedure. You are expecting actual failure at any time. You must be familiar with the operating manual and immediate action emergency procedures for your airplane.

Engine Cranking and Starting

When starting, you should understand the conditions that can occur in the combustion chambers, how to introduce fuel, and how to control the fuel/air elements.

Most operating manuals for small aircraft indicate a 30-second limit for continuous cranking of the engine. In reality, many modern starters have 10-second limitations so it is imperative you understand your specific aircraft limitations.

You must be aware of your aircraft starter limitations, if the engine does not start immediately, limit cranking to 5-10 seconds. It is seldom necessary to crank more than a few seconds. In that amount of time, it is obvious conditions are not right to obtain a start.

For your engine to start, you must meet two criteria. There must be properly vaporized fuel introduced into the combustion chamber, and there must be an ignition spark to ignite the fuel.

Ignition

Aircraft engines have dual ignition magnetos and corresponding dual spark plugs. It requires a double failure in the generation of the spark from the magnetos or fouling of both spark plugs in all cylinders causing complete loss of ignition.

In the case of a flooded engine with the introduction of too much fuel, it is possible for all spark plugs to be wetted, to the extent they do not fire.

Cranking causes intake vacuum in the cylinders. In cold weather, it is possible the reduced air pressure can allow moisture condensation, which can frost over the cold spark plugs, preventing them from causing ignition spark.

Starting Fuel

In the heat of summer, when you are starting a hot engine, it is common to have engine flooding. Fuel easily vaporizes from residual heat, and even a slight excess could create a too-rich mixture.

The input of throttle control is also a consideration during cranking. The throttle control, connected directly to the butterfly valve, adjusts airflow into the induction system. Opening the throttle increases the available air for changing the fuel/air ratio.

Fuel priming is the initial source of fuel for starting a carburetor-equipped engine. You manually operate the primer pump, spraying a small amount of fuel near one or more of the intake valves. Each cycle of pushing the primer pump adds a small quantity of fuel.

At the beginning of cranking, the partially vaporized fuel sucks into the combustion chamber. The quantity of fuel priming, the amount of air allowed through the induction system, and the prevailing temperature in the engine will determine the amount of total vaporization and the resulting fuel-vapor/air ratio.

In average conditions, the engine will start almost immediately upon activation of the starter. If the ignition does not begin immediately, it may be required to open the throttle slightly, to allow more air for vaporization. This would probably be normal in most conditions.

Shortly after the beginning of cranking, intake air through the carburetor will also begin drawing fuel from that source. Little fuel is initially available from the carburetor at the slow rpm of cranking.

Opening the throttle butterfly valve allows greater airflow into the engine. A common technique of pumping the throttle, opening and closing the butterfly valve, is merely varying the airflow through the intake manifold system while causing little or no change to the amount of fuel introduced at the carburetor.

While cranking, pushing the throttle wide-open deposits a small amount of fuel into the carburetor throat from the accelerator pump. This is an alternative way of introducing fuel into the induction system when cranking.

Use care, not to have excessive fuel that could drain and accumulate in the bottom of the carburetor, and in case of backfire possibly result in a carburetor fire.

Continue cranking enough to allow the engine to draw any possible burning fuel back into the engine if the engine has not yet started.

Accelerator Pump

The last approximately one-half inch of throttle input activates the acceleration pump to deposit a small amount of fuel directly into the induction system at the carburetor. This pump, built into the carburetor, assures sufficient fuel is available, for rapid acceleration, during normal running engine operation.

The carburetor accelerator pump is available for input of additional fuel during start, if necessary, but requires careful use.

Engine Fire While Starting

Any time you move the throttle full forward, there will be some fuel deposited into the induction system at the carburetor by the accelerator pump. It is possible by pumping the throttle full forward several times to have an excess of fuel accumulate in the bottom of the carburetor system.

A backfire of the engine during cranking could ignite this fuel resulting in a carburetor fire. Continued cranking will usually draw any fire into the engine with no adverse results.

Stopping cranking at that time could allow the fire to continue to the extent of destroying the aircraft. It is imperative you understand the use of the throttle and starter during start.

Fuel Conditions for Starting

You also must understand the requirements that allow the fuel to ignite during engine start. Fuel-vapor/air mixture ratios, that will not ignite when starting, are mixtures referred to as too lean and too rich.

With fuel-vapor/air mixtures that enter the combustion chamber, there is a small range (approximately 12-15 parts of air to one part fuel-vapor, by weight) which will ignite resulting in engine start.

During start, a “lean” mixture refers to too little fuel and a “rich” mixture refers to too much fuel for the available air (oxygen). Elimination of a too rich mixture, “flooded”, condition can be by shutting off the mixture control, and cranking thereby pumping large quantities of air to rid (“dry out”) the combustion chamber of excess fuel.

Note that during the cranking, to dry out the combustion chamber, the fuel-vapor/air mixture will pass a condition of proper mix, and ignition could occur. With prompt action, pushing the mixture control in, to turn on the fuel, the engine will start!

This procedure is called a “flood start” when done deliberately.

Conditions for Starting

Consideration of the probable conditions, prior to cranking, will allow you to make a reasonable decision of the amount of priming necessary and any additional inputs that may be required. There are often individual techniques developed for different engine types.

Engines, with fuel injection systems, have all metered fuel directed to the intake valve area, and the carburetor is merely a throttle control for air input with the butterfly valve.

These engines will not have to be primed, though consideration of the conditions in the combustion chamber to predict the condition of the fuel, and the vaporizing airflow is required.

The fuel injection systems, when hot, after shutdown, can have residual fuel vaporize in the fuel supply lines causing vapor lock. Most of these systems have a purge valve for circulating fuel into the system. Technique varies depending on temperatures.

Restarting a hot engine within a few minutes after shut down may require only cranking. The longer the engine shut down and the higher the temperatures, the more vaporization that has possibly taken place within the fuel lines. It can take several seconds purging before trying the start.

A basic premise in starting of all engines, the colder the temperature, the more priming that may be required. To attain sufficient vaporization, more fuel may be required in the system. At higher temperatures, sufficient, or excess vaporization, often occurs.

Summary

- Systematic use of procedures and checklists are necessary to assure a safe operation.
- Optimized starting fuel vaporization and air mixing take place with flow through the carburetor or at the intake valve area for fuel-injected engines.
- Fuel vapor/air mixture is lean when the ratio is too much air and rich when too much fuel.
- The manual throttle operates the carburetor butterfly valve for control of air intake.
- The accelerator pump introduces a small quantity of fuel at the carburetor when opening the throttle manually to full forward open position.
- Cooling from rapid expansion of the fuel/air mixture can cause ice accumulation in the carburetor throat when humid air conditions exist.
- Indication of carburetor ice is reduction of rpm or manifold pressure.
- Engine oil temperature and pressure require monitoring at all times. Loss of engine oil is an emergency requiring immediate landing.
- Engine starters have short operational time limits.
- Ignition only occurs with proper fuel/air ratios.

- Correct the engine starting when the mixture (flooded) is too rich, by shutting off the fuel and cranking to purge the cylinders of fuel.
- Accelerator pump use during start can introduce excessive fuel into the carburetor.
- The prevailing environmental temperature and humidity affect starting condition.



GLOSSARY—INDEX

The following numbers designate the page using or defining that word or term.

Abort: 70, 77-80, 98, 106-107

To stop or end.

Abort Approach or Landing: 161

Stop descent while adding power and configuring for continued takeoff flight.

Abort Flight: 161

When airborne; return for landing.

Prior to takeoff; cancel flight and/or return to parking.

Abort Takeoff: 161

Stop takeoff run/roll prior to becoming airborne.

Acceleration: 2, 16, 25-27, 30-34, 41, 45-51, 55, 65, 76-83, 95, 98, 101, 103, 106, 111-11, 115

Increase of speed or velocity. When operating on the surface excess thrust causes increased speed. The instant the aircraft attains sufficient indicated-airspeed for generation of lift equal to its weight it becomes airborne. At that moment, acceleration stops and climb begins.

Airborne acceleration comes from reducing angle-of-attack, down/away elevator or nose down elevator trim input reducing the frontal-plate area and *allows* the airplane to accelerate. The coordination of power will determine the lift for maintaining level, climbing, or descending flight while *causing* acceleration.

Aerodynamic Lift: 3-4, 6-13, 18, 21-29, 33, 38, 44, 47-48, 65

The outward reactive force of airfoils from air mass encounter of the aircraft motion. Wing and body lifting is out the top of the structure and elevator lifting/loading can out the top or bottom of the horizontal tail structure.

Aerodynamic Form: 19

Physical shape of an aircraft that minimizes resistance to travel through an air mass causing force reactions for generating lift.

AGL (Above Ground Level): (see MSL)

Altitude expressed as feet above terrain.

Ailerons: 22, 34-36, 37, 62, 86, 90, 93,

Flight controls for turning. Hinged to the outer trailing edge of the wings and operate in opposite directions to each other from input by the pilot rotating/turning the control wheel or moving a control stick left or right. Movement of the ailerons causes change in lift at the outboard portion of the wings. With one going up and the other going down the resulting unbalanced wing lift will create bank/roll force vectors around the longitudinal axis relative to the pilot and cause turning.

Aim point: 85

Distant reference toward which directing the aircraft for heading and attitude control.

Air Density: 20, 30, 41, 96-98

The mass of a unit volume of air as determined by its pressure, temperature, and humidity.

Low-density air mass contains reduced oxygen for burning, restricting engine performance in reduced air density conditions.

Flight in low-density air requires increased velocity to encounter sufficient mass for maintaining constant lift pressures.

Air Impact Pressure: 162

Measurement of air resistance with the pitot system (the instrument is calibrated as speed) when moving within an air mass.

When related to lift pressure from encountered airmass around an airfoil, measured in lbs. per square inch. Sixty-five kts. indicated-airspeed is approximately 1 lb. per square inch.

Air mass (an): 3, 28-30, 108-110

Large area of the total atmosphere that is distinct by reference to its relative temperature, pressure, humidity, and related movement over the surface of the earth.

Airmass: 3,6-11, 17, 20- 22, 28-30, 76, 96, 109

Mass-of-the-air, the elemental mass per unit volume of the atmosphere.

Airmass Dynamic Displacement: 162

The aircraft moving through an air mass creates flow of the air relative to the machine. It is continually displacing this air by the frontal area of its structure encountering the free-stream air. This displacement of air creates changes in direction of

flow around the form with resulting retarding pressure and frictional drag forces and reactive lifting forces. The actual flow results from the specific designed aerodynamic shape of the aircraft.

Airspeed (Indicated): 1-2, 4-6, 9, 11, 13, 18-22, **25-31**, 34-35, 38
40-41,44-52,

Relative velocity within and through an air mass from encountering pressure as measured on the Indicated-airspeed pressure instrument. Elevator trim allows adjusting the air impact/dynamic displacement angle/frontal plate surface area (angle-of-attack) of the aircraft into the airstream (relative wind). (All reference to aircraft operational airspeeds is indicated-airspeed as read on the aircraft instrument.). There are many different aspects of airspeeds related to the installation of the indicated-airspeed indicator. The pilot has no control over these things. When inflight the pilot flies relative to the actual indicated airspeed reading he makes.

Airspeed (True): **28-29**,41,96

Velocity relative to the air mass. The distance traveled over time within the specific air mass.

Airstream: 4, 9, **35**, 42

Flow of air around the aircraft from the motion effects of aircraft encounter and displacement.

Altitude: 1, 5, 16-21, 25-26, 28-81,**95-128**

The distance vertically upward relative a reference to the earth's surface. Flight normally operates as distance above sea level.

Altimeter : **96**, 98-99

A sensitive barometric instrument indicating an aircraft's altitude above mean sea level by measuring atmospheric pressure.

Altimeter Setting: **163**

Related to local barometric pressure and used as a reference setting to indicate an accurate altitude. Above 18,000 feet, all flights use a standard setting of 29.92 inches of mercury.

Angle-of-attack: **8**, 11-13, 20-22, 25-29, 34, 38-52, 57-58, 62, 65-67, 70, 83, **101-108**, 111, 115, 116

The angle of the dimensional longitudinal axis above the effective longitudinal axis (direction of motion) as the aircraft encounters the free-stream air.

Angle of Incidence: 11

A small upward angle between the wing chord and the aircraft axis, a fixed angle of attachment of the wing to the fuselage.

Approach: **25**, 30-32, 54, 58, **60**, 61, **65-67**, -83, 89-97, 102, 105, 108-118, **122-129**

The maneuvering of an aircraft to track over the extended runway centerline while descending toward its landing area. This is flying a visual Directed-Course to the selected landing area (aiming at a landing area). The airplane configured for landing and elevator trimmed to a landing indicated-airspeed.

A.T.I.S.: **164**

Airport Terminal Information Service

Continuous broadcast of airport information for arriving and departing aircraft. Includes runways in use, weather, and winds.

Named by aviation phonetic letters (i.e. Information "Yankee" for "Y" could be the name of the current information).

Atmosphere: **3**, 9, 28, **95-96**, **98**, 102

The total air mass surrounding the earth composes the atmosphere. The earth's gravitational effect on the mass of air results in it being denser near the surface. Movement through the atmosphere of air causes lift with appropriately design-shaped and powered machines. Proper displacement of a sufficient mass of air with motion suspends the airplane within the atmosphere.

Attitude: 1-12, 7, 16, 20-26, 33-54, **55-61**

Orientation of the airplane in space relative to the earth's surface or to the pilot. Typical inference is an aircraft being in a "straight and level" attitude. This means constant heading, altitude, and indicated-airspeed, with wings level to the horizon. Any variation from straight and level is a change in bank attitude (roll), pitch attitude (climb or descent), or any combination of these.

Attitude Roll: 165

Airborne rotation of the aircraft around the effective longitudinal axis.

Away/From: 165

Pushing the Elevator control causes pitch (reduced angle-of-attack) change in a direction away from the pilot no matter the attitude.

Axis of Rotation: 165

An imaginary straight line about which rotation occurs. Any one of three lines intersecting at the effective center of gravity (load) and defining the in-flight attitude of an airplane. One determined by the direction of forward motion and the other two at right angles to it and to each other.

Back/To/Pull: 61

Pulling the Elevator control causes nose pitch in the direction toward the pilot thereby increasing the angle-of-attack.

Balance: 1-2, 9, 12-14, 26, 33, 36, 38, 44, 46, 49, 51, 96

Equalizing the forces of lift-load and thrust-drag to maintain a desired constant attitude.

Bank/Roll: 36, 42

Inflight maneuver for turning or slipping by rotation about the effective longitudinal axis causing an angular attitude to the direction of motion.

Bank Angle: 37, 52-53, 57, 66-69, 90, 106

The attitude angle of rotation about the effective longitudinal axis to a specific attitude angle relative the surface.

Base Leg: 67-68, 70

The crosswind portion of a landing pattern prior to the final approach. A descending path from the downwind leg toward the final approach leg.

Bernoulli Effect: 7-9, 29

The velocity of airflow over the wing increases with the voiding by air mass displacement.

Best Glide (V_{bg}) Indicated-airspeed: 73-74, 118, 123-124

The indicated-airspeed that gives most ground distance when gliding, attained from an optimum rate of descent of the aircraft.

Body Angle: 9-11, 40, 43, 45

The angle between the inflight direction of motion and the dimensional longitudinal axis. The angle-of-attack of the aircraft body.

Brakes: 37, 62, 81, 87, 93

Taxi deceleration input by applying foot pressure on the brake pedals mounted on top of each rudder pedal controls individual main wheel brakes. The left pedal brakes the left main wheel and the right pedal brakes the right main wheel. Nose wheel steering while braking is with input of individual rudder pedals in the direction of desired movement.

Camber: 166

The asymmetry between the top and the bottom curves of an airfoil cross-section.

Center of Gravity/Center-of-mass (static c.g.): 166

The static center of gravity acts at the averaged location of the components of aircraft mass and the loading. It changes with changes in aircraft mass loading and placement of that mass. An airplane is a combination of many components, the wings, engines, fuselage, and tail, plus payload and fuel. Each component has a weight force and moment arm associated with its location on the machine. The center-of-mass does not change with aerodynamic loading.

Center of Load : Inflight (effective c.g.) 14-16, 23, 38-39

The elevator control adjusts to create aerodynamic lift or loading for balance of the center-of-mass along the longitudinal axis. For typical dynamically stable aircraft, generating aerodynamic load on the elevator and horizontal stabilizer balances the aircraft. Loading causes an increase in the apparent weight (loading) of the aircraft. This changed load relative the position of the center-of-mass creates a changed “effective center of gravity (load)”. The loading force created by the elevator changes angle-of-attack pitch and a corresponding change of the center of pressure.

Center-of-Mass (See Center of Gravity): 4, 17, 21-22, 25

Center of Pressure (Effective CG): 13, 14, 16,35,38

The point at which all force components of mass and aerodynamic load and opposing vertical lift are acting on the effective longitudinal axis to maintain current balance.

Chord Line: 167

A straight line from the trailing edge through the leading edge of the wing used as reference for measuring wing angle-of-attack from the relative-wind and the angle of incidence to the aircraft.

Clean Configuration: 42, 75

All flight devices such as gear, flaps, spoilers etc. retracted from encountering the airstream.

Clear: 79, 83, 130

1. Visually checking the area for safe operation, no obstacles, or obstructions.
2. Condition of no obstruction to visibility or motion.
3. A weather condition of no visible clouds.
4. "Clear", a loud call made before starting the engine.
5. Cranking the engine with fuel shut off to remove residual fuel in the cylinders by introducing excess air.

Clearing Turns: 131

Shallow bank-angled turns usually less than 10 degrees of bank and heading change to allow sighting of conflicting traffic above and below when maneuvering, climbing, or descending.

Climb: 1, 5, 11, 17, 19-21, 26, 30-35, 40, 44-45, 48, 49-51, 53, 55-57, 63, 66, 76-79, 82-83, 96-100, 102-103, 107, 128

Increasing altitude. Excess power causes climb, an input greater than that required to sustain level flight at a specific indicated-airspeed.

Climb-Pitch: 34, 44, 102, 107

The increased angular attitude above level sustained flight that causes climb angle.

Coanda Effect: 7, 8, 11, 29, 104

The tendency of a moving gas or liquid to travel close and along the contour of a curved surface.

Collision Course: 53-54, 60, 62-65, 74

1. A course or path of travel that, if unchanged, will lead to a collision with another aircraft or object.
2. An inadvertent course normally discovered when scanning for other traffic in flight. If a sighted object does not move relative to a point on the window, it is on a collision course.

3. Interception of an aircraft in-flight by maneuvering to have that flight unmoving on the window thereby establishing a collision course toward it.

Configuration: **5, 42, 47, 60-61, 72-81, 85-89, 109, 111-123**

Position of flight devices such as gear, flaps, spoilers etc., extended or retracted into the airstream.

Course: **53-54, 58, 60-63, 67, 70-76, 85, 89, 110, 118, 120, 123-124.127**

A direction or route taken or to be taken. The route along which the aircraft moves. Progression in a particular direction.

Crab/Crabbing: **75, 82, 89**

Heading correction toward/into a crosswind to maintain a specific course.

Critical Angle-of-Attack: **11-12, 21, 46, 67, 101, 102, 104, 107-108, 115**

Angle-of-attack at which the laminar flow of the airstream, the Coanda effect, causing changed direction of airflow over the top surface will separate resulting in loss of lift, stalling.

Crosswind: **31-32, 61, 68, 72, 75, 79, 82, 85, 87-88, 89-92, 93**

The travel of an air mass (real wind) when not directed toward the nose or tail but crossing the course.

Crosswind Component: **32, 75, 82, 89, 91**

That Vector-component direction and velocity of air mass movement perpendicular to a direction of reference or flight.

Deceleration: **21, 33, 41, 45, 49, 50, 55, 62, 78, 85, 88-90, 99, 102-103, 120-121, 125**

Reduction of speed and/or indicated-airspeed.

When airborne, increasing angle-of-attack *allows* deceleration. Increased back/to elevator input or nose up elevator trim input increases the frontal-plate area *allowing* the airplane to decelerate. Increased frontal-plate area *allows* reduced encountering pressure per square inch to maintain the aircraft weight. Coordination of power will determine the lift for *causing* level, climbing, or descending flight while decelerating.

Density Altitude: **20, 96**

Pressure Altitude corrected for temperature and humidity. Air density (atmospheric pressure) decreases with increased altitude, temperature, and humidity. Warm air is less dense than cold air because there are fewer air molecules (less mass)

in a given volume of warm air than in the same volume of cooler air. Humid air has less mass than dry air. Less dense air therefore contains less oxygen per unit volume, which reduces the power possible from engines.

Descent: 3, 16-18, 21-23, **25-27**, 33, 35-36, 41, 42, **44**, 45, 49-55, **58-61**, **65-88**, 70-79, 85-87, 102-104, 107-108, 112, 115, 121-124
Decreasing altitude. Descent is by decreasing engine powered thrust from that needed for sustaining level flight. Reduction of power results in the airplane starting to descend allowing generation of a sustaining horizontal gravity component-thrust to maintain the indicated-airspeed at that called for by the angle-of-attack.
The descent angle (negative climb angle), controlled by elevator pitch, will be dependent on the amount of power reduction when maneuvering into a descending direction by decrease of thrust or elevator-pitched change of attitude. Reduction of angle-of-attack and subsequent acceleration without coordinated increase of engine power causes descent until power and density altitude again balance.

Descent Angle: (See Climb/Descent Angle) 17, 50, 60, 71-73, 102
An angle of aircraft attitude travel below level flight.

Direct Course: 169

A course that proceeds by the shortest distance toward a specific point or destination; Straight-line shortest distance path to pass over a point. A "direct" course for navigation will pass over the destination. A "directed" course will fly a descending path to the destination (a collision course).

Directed-Course: 55-56, 60, 62, 69, 73-78, 89, 93, 122,124,-127-128
A planned or deliberate visual collision course used for normal flight maneuvering and attitude control. It is a collision course in that it too could lead to collision if maintaining the course. The horizon, maneuvered as a fixed line, sighted across the windshield, becomes a Directed-Course for pitch control. The horizon placed, as an angle sighted or pictured across the windshield becomes a visual reference for a specific bank angle. A point or specific object sighted/pictured on the horizon becomes a Directed-Course for heading control. A specific point, object, or destination on the surface fixed in an unmoving position on the windshield becomes a Directed-Course for visual control of heading and angular attitude and for descending to that specific point, object, or destination.

Direction of Motion (Attitude Motion): 2, 3, 5-6, 11, 17, 22-23, 28, 33, 37-38, 40-45, 61, 67, 70-72, 82, 85-86, 90, 102

The aircraft motion is always forward opposite the relative-wind though orientated in any attitude including climbing, descending or turning or any combination of maneuvers.

Direction of Flight (Compass direction): 170

A horizontally orientated, compass direction as related to earth's magnetic North.

Downward: 6, 8-9, 83

Referring to direction away from the aircraft toward the earth.

Downwash: 7-8, 30, 46, 76

Displaced airmass accelerated into a downward motion from passage around the surface of an airfoil.

Downwind (tail wind): 60, 67-68, 70, 76, 78-79, 119

Flight in the same direction a component of the real wind is blowing.

Downwind Leg: 60, 67-68, 70,

The leg of a standard traffic pattern on which the traffic flies parallel to the landing runway in the direction opposite that of landing.

Drag: 1-3, 17, 21, 22-26, 30, 33, 37, 42, 45-46, 48, 50, 72-74, 76-79, 83, 85, 102, 106, 107, 111, 118, 124,

The reaction force on the aircraft opposite the direction of motion through an air mass. A resistive force induced by airflow impaction, displacement, and friction of flow due to movement of the body through an air mass, plus any aerodynamic or gravity force components directed rearward. The resultant combined forces exerted on a body moving through the air and always in a direction opposite the body's motion.

Drift: 28, 61, 68-91, 111

Deviation from a selected course across the surface due to air mass movement within which conducting an operation.

Drift Correction: 170

A heading (correction) turned toward/into any air mass movement to enable maintaining a specific (desired) ground track. (wind effect correction)

Dynamic Displacement: 171

Free-airstream mass displacement due to encounter from motion of the aircraft.

Effective Center of gravity (load) (Inflight): 15, 23-25, 38-39

The elevator control adjusts to create aerodynamic lift or loading for balance of the center-of-mass along the longitudinal axis. For typical dynamically stable aircraft, generating lift or load on the elevator and horizontal stabilizer balances the aircraft. Aerodynamic loading causes an increase in the apparent weight (loading) of the aircraft. This changed load relative the position of the center-of-mass creates a changed “effective center of gravity”. The loading force created by the elevator changes angle-of-attack pitch and a corresponding change of the opposite acting center of lift both through a center of pressure.

Elevator: 1-3, 11-15, 20-28, 34-35, 37-52, 55-70, 72-73, 77-83, 86-88, 93-94, 96, 101-107-128

Control surface attached to the trailing edge of the horizontal stabilizer. Pilot input to the control wheel or control stick by pulling aft and pushing forward causes deflection of the elevator with changed aerodynamic load/lift resulting in the airplane nose moving to or away relative to the pilot when in flight. This results in changing the angle-of-attack frontal area to the relative-wind for indicated-airspeed control.

Elevator positioning with the pilot holding the nose up during initial landing touchdown can aid in braking efficiency by adding pressure on the main gear during landing roll while slowing.

Elevator-Pitch: 11-13, 20-22, 25-28, 37-41, 44-51, 55-58, 61, 65-76, 78-79, 86-87, 93, 101-117, 121-124

The elevator control wheel, forward and aft movement adjusts elevator-pitch. Elevator-pitch adjustment is rotation of the fuselage around the effective lateral axis to control the aircraft angle-of-attack. Elevator-pitched settings allow specific indicated-airspeeds at which the aircraft will fly.

Elevator Trim: 28, 38, 41, 51, 66, 78, 81, 102-104, 115-116, 128

The trim control is typically a small non-calibrated wheel, adjusted by rolling pitch up to increase encountering angle for slower indicated-airspeed or down to decrease this angle for faster indicated-airspeed. Some aircraft have an electrical switch for setting elevator trim.

Pilot input allows changing the elevator neutral setting by creating a desired angle (angle-of-attack), frontal plate area of impact/dynamic displacement, to the relative wind. A specific indicated-airspeed results. When trimmed to attain a desired indicated-airspeed, it enables hands-off flight of elevator control.

Emergency: **52**, 62-63, 73, 76-78, **92-93**, 101, 113, **117-125**, **128**

An occurrence putting the aircraft safety at risk.

Empennage: **13**, **35**

Aft section of the aircraft incorporating the vertical and horizontal stabilizers, rudder, and elevator.

Energy: **16-17**, 21, 33, **34-35**, 48, 51-52, 70, 83, 118, 121-122,

Potential energy (energy at rest or stored) obtained from position (descending from altitude) and chemical (burning fuel).

Kinetic energy (energy of motion), the momentum of mass (the motion of the aircraft).

Engine: 1-6, 11-**13**, **18-23**, 26-27, 29, 38-52, 55-58, 79-74, 78, 81, 87, **93-110**, 116, 117-120

A device for converting potential energy of fuel creating power to cause thrust.

Engine-Lift: **13**, 26, 44, 69, 103

Engine thrust component-lift caused by an aircraft pitched attitude (angle-of-attack) above the direction of motion.

Engine Power: 11, **17-18**, 34, 39-40, 42, 45, 50-52, 56-57, 72-74, 87, 93-97, 99, **102**, 107, 117

Available engine performance. Power is dependent on physical mass of air intake. With low-density air (low mass to volume) at high altitudes and/or with high temperatures the engines cannot intake sufficient oxygen for burning to develop full sea-level rated power.

Excess Thrust: **19-20**, 34, 41 44, 46, **48**, 56, 66, 78, 98-99, 103, 128

Applied engine thrust above that required for sustaining a constant level flight indicated-airspeed condition.

Extended Centerline: **67-68**, 71, 79

An imaginary extension of the runway centerline away from the runway.

FAA (acronym): 173

Federal Aviation Administration regulates the operation of aircraft in the U.S.A.

FAR (acronym): 173

Federal Aviation Regulations- The rules and regulations covering all aviation.

Final: 25, 54, 60-61, 67-68, 70-79, 87, 106, 110, 114, 119,

The portion of the traffic pattern flown over the extended centerline descending directly to the landing runway.

Flaps: 42, 67, 73, 75, 78, 83, 85, 87, 121, 123-124

Panel devices attached to or within the wing trailing edges allowing extension for increasing wing surfaces to enable slower flight indicated-airspeeds.

Flare: 61, 75, 80, 86-88, 106, 112, 119, 123

Continuing the landing roundout, causing the attitude to become slightly nose up as the aircraft slows and sinks to the surface, allowing the main wheels to touch down first.

Float: 73, 87-88, 123

Continued flight, during a landing, when leveling for touchdown, the aircraft has not slowed enough to sink to touchdown due to excessive indicated-airspeed, ground-effect, and/or continued holding excessive manual aft elevator input.

Force: 1-7, 10-22, 26-28, 33-37, 42, 45, 47, 49-50, 58, 69, 75, 86, 88, 90-91, 95, 108, 110-111, 113, 119, 122

Putting mass into motion or changing its rate or direction of motion. Propel against resistance

Force Vector: 3, 21, 110

Representation of a force's magnitude and direction

Force Component-Vector: 173

Related directional forces when a vector is divided into components 90° to each other. The directional components F_y and F_x are 90° to each other. Component vectors represent separate forces which when exerted in their specific directions result in the reactive force F . Example, if angle θ is 60° , $F_y = .866$ lb. and $F_x = .5$ lb. Exerting these two force vectors in their directions results in a force $F = 1.0$ lb. in its specific resultant direction

Forward: 1-3, 5, 13, 17-18, 22, 25, 27, 39-41, 44, 61-62, 71, 81-82, **85**, 90-91, 96, 100, 108, 117-118, 120, 123, 126
Relative to the Pilot, the direction of aircraft motion, no matter its attitude.

Free-Stream Air: **40, 45, 49, 108**
The uninterrupted undisturbed free air of an air mass prior to flight encounter.

Friction: 2-3, 16-17, 22, 36, 62, 76, 87, 91
Any retarding force created when a combination of two objects or fluids in contact move in different directions to each other.

Frontal-Plate Area: **8, 41**
The total area of the aircraft structure that encounters and displaces free-stream mass-of-the-air. Angled motion causes the volume of air displaced to be greater than the aircraft volume.
To maintain a specific indicated-airspeed, the angle-of-attack requires a frontal-plate area to the relative-wind to balance the displacement/pressures (lbs. /sq. in.) of the encountering free-stream air.
If indicated-airspeed is increased, the airflow volume increases, with related increased vertical displacement pressures, so it requires a reduced angle-of-attack frontal-plate area to maintain the same vertical lift.

Fuselage: 3, 9, 11-13, 23, 38, 44-45, 48, 69, 86, 122-123
The body of the aircraft.

“g” Force: 1-2, **26, 50**,
The force exerted on an object by gravity and always directed vertically toward the the earth. This force is equal to the weight of the object.
In a turn, the centripetal force generated adds to the total aircraft loading. A level 45-degree turn will generate an additional .4 times the object's weight (1.4 g).

Glareshield: **126**
The covering over the area above and between the instrument panel and windshield, generally colored to prevent sun glare (reflection) on the instruments or into the Pilot's eyes.

Glide: **5,18, 27, 30, 49, 71-74 117-118, 123-124**
Flight with reduced or no engine power, using gravity component-thrust, and/or momentum.

Glide Angle: 18, 73-74

Engine out or engine idle-thrust angle of descent from level flight.

Glideslope: 71,

The descending path of travel for landing approaches.

Glide Speed: 175

Gliding indicated-airspeed when reducing or losing power and sustained by gravity component-thrust.

Go-Around: 65, 68-70, 75, 77-78-79-80,85, 87-88, 92, 107, 110

The procedure of aborting a landing or landing approach, consisting of adding power, leveling, accelerating, and climbing while adjusting and configuring toward a takeoff procedure.

Gravity: 1-4, 11, 15-18, 21-22, 27, 33-39, 42, 45, 48-52, 65, 96-97, 101-102, 104, 111, 115,

The acceleration force of attraction of the earth's mass to the mass of an object. Gravity is a source of generating movement in an aircraft in flight. The gravity component-thrust is similar to engine thrust but always requires descent. (Consider gravity a thrust force equivalent to the mass weight and always directed toward the surface.)

Gravity component-thrust: 1, 3-4, 17-18, 21-22-23 26-27, 33-34, 38, 45, 49-52, 65, 96-97, 102, 104

The aircraft in a descending attitude angle (negative climb) has a forward component from gravity acting at the center of mass.

Ground: 2, 14, 16, 28, 30, 33, 36-37, 53, 55, 57, 61-62 68, 71, 73-74, 76-77, 81-83, 85-91, 95, 98, 106, 108-109, 112

1. The surface of the earth.
2. Abbreviated term for airport Ground Control.
3. The neutral of an electrical circuit.
4. Shorting an electrical circuit by connecting the hot wire to neutral or the surface.

Ground-effect: 30, 74, 76, 82-83, 87, 106, 120, 124

Increased air pressure below an airplane when flying very low. Maximum effect is at the surface and essentially disappears at one wing length of altitude. It results in reduction of up-wash, downwash, and wingtip vortices, providing a corresponding decrease in induced drag.

Ground Roll: 176

Landing: The distance required from touchdown to stop.

Takeoff: The distance required from brake release to the wheels leaving the runway becoming airborne.

Groundspeed: 28, 61, 89, 91, 109

Actual velocity relative the earth's surface.

Movement over time relative to the surface.

True airspeed corrected for the effect of air mass movement across the surface.

Gust (Wind): 82, 91, 93

Intermittent and sudden changes in wind velocity.

Gust Front: 93

The leading edge of a fast moving air mass, often associated with thunderstorms, and possibly visible by dust carried along.

Gyroscopic Precession: 81

A left turning force from rotation of the engine and propeller requiring coordination of control with rudder steering.

Heading: 24, 32, 52-53, 56-57, 61, 81, 86-87, 89

The compass direction the aircraft is pointed. A no-wind course.

Headwind: 32, 85, 89, 91, 93, 109

That Vector-component of air mass movement (real wind) opposite the direction of flight or a referenced course.

High-Density Altitude: 176

A relative altitude related to a standard when considering the density of air. Low-density air occurs at high-density altitudes.

Horizontal Stabilizer: 13, 35, 37-38, 44, 48, 56-57

Small aerodynamic airfoil normally mounted horizontally on the tail (empennage) for flight stabilization. An attached elevator allows nose up and down pitch steering for angle-of-attack indicated-airspeed control. Some aircraft have adjustable stabilizers for pitch and pitch trim.

Hypoxia: 98

Deficiency of oxygen to the body. This occurs with extended operation at higher altitudes and depending on the physical condition can affect a person at altitudes below 10,000 feet. Above 15,000 feet, useful consciousness may be a little as five minutes and at 25-30,000 feet, 5 to 15 seconds.

Indicated-airspeed: 1, 2, 4, 6, 9, 11-12-13, 18-22, 25-27-30, 34-35, 38, 40-41, 44-52, 55-61, 65-92, 96-128

Reading of the indicated-airspeed instrument within the aircraft. Reference airspeed for manipulation of the airplane and calibrated in units of speed. This reference is a measurement of the impacting/ram air pressure into the pitot system as an indication to the pilot of relative mass-of-the-air pressures against the aircraft structure.

Indicated-Airspeed Indicator: 27, 30, 117

Cockpit instrument showing pressure airspeed for monitoring aircraft performance.

Induced Drag: 22, 25-26, 46, 50, 102, 111

Rearward component of lift and gravity forces. Drag increases with increased angle-of-attack as the machine moves within the air mass. It tends to be greater at lower indicated-airspeeds because higher angles of attack result in increased frontal-plate area, greater volumetric displacement, and related increased travel of the airflow around the structure.

Inertia: 177

The property of mass by which it retains its state of rest or its velocity along a straight line so long as not acted upon by an external force.

Inverted: 42-43,

Aircraft attitude with normal lift forces orientated toward the surface.

Instruments: 81, 127

Devices in the cockpit for measuring and monitoring system operation, flight attitude, and condition.

Laminar Flow: 11, 113

The flow of air particles in parallel layers along or across a surface in motion relative to neighboring layers.

Landing: 25, 30-33, 37, 42,49, 54, 60-62, 65, 67-77, 79-80, 85-94, 104-106, 109-112, 117-125

The maneuvering of roundout, flare, touchdown, and rollout to stop.

Landing Gear: 42, 121-123

The aircraft undercarriage; main wheels and nose wheel.

Landing Roll (Ground Roll): **80**, 85, 92-93,

The distance required from landing touchdown to stop.

Landing Area: (aiming point) **30**, 60-61, 67-68, 70-76, 88-**90**, 105, 118, 120-124,

An area on the surface chosen for landing.

An aim-point for controlling a visual Directed-Course of travel toward the selected landing area, the touchdown point will normally be just beyond.

Level Flight: **17**, 21, 26, 30, 40-41, 44, **47**, **49**, 51, 55, 57, 66-67, 70, 82, 96-97, 99-100, 103, 107

Upon reaching a specific altitude, forward elevator control to maintain level altitude and allowing acceleration to the desired cruise indicated-airspeed. Coordinated reduction of power will cause stabilized constant indicated-airspeed, constant altitude flight. When attaining both cruise altitude and indicated-airspeed, by coordination of elevator trim for indicated-airspeed, and power for altitude, the airplane will try to maintain itself with hands-off control.

Lift: **1-18-52**, 57-58, 61, 65-66, 69-70, 76-78, 81-83, 87, 91, 96, 101-104, 107-111, 114, 117

A force away from the top of the machine in any attitude.

Lift (Aerodynamic): **178**

See, Aerodynamic Lift

Lift (thrust component-lift): 1-4, **12-13**, **17**, 212, 27, 34, 36, 39-49, 58, 65-66, 69-70, 78, 102-104, 116

The component-lift at the aircraft engine thrust attachment, and caused by the angled attitude of the aircraft above the direction of travel (motion).

Load: 1-3, 12-13, 15-17, 21, **23-26-27-29**, 37-39, 44, 46-48, 50, 52, 56-58, 68-69, 83, 102, 105-108, 114

The forces opposing lift. This involves both the gravitational force directed toward the earth plus any aerodynamically generated force from an airfoil directed opposite the lift vectors. Aerodynamic loading will be negative lift from the elevator and/or centrifugal “g” loading when maneuvering away from wings level constant altitude flight.

Load Factor: **26**, 50

The ratio of the aerodynamic load on the structure to the weight of the aircraft. A current “g” loading.

Loiter: **5**, 46, 119

Maximum Endurance (V_{me}); Indicated-airspeed at which an aircraft can remain airborne the longest time.

Longitudinal Axis: **3**, 11 **23**, 43, 75, 86, 90

Dimensional: A line directed through the static center of gravity of the aircraft front to back, and parallel to the structure of the body.

Effective: A line directed through the center of pressure (load) of the aircraft front to back, in the direction of motion, parallel to the line of flight.

Maneuvering: 1, 3-5, 15-17, 19-26, **33-34**, 37-39, 41, **45-46**, **48-49**, 51-54, 62-63, **65-66-68**, 70, 76, 80, 82, 87, 95, 99-106, 108, 110
The act of steering and guiding the travel of the machine.

Mass: 1-4, 6-22, 25-34, 38, 76, **95-104**, 108-110, 119

The magnitude of elemental matter due to gravitational force. Determined as the weight per unit volume

Mass-of-the-air (airmass): **1**, 3, 6-7, 16-17, 29, 34, 96, 99-100

The quantity of air as determined by its elemental mass weight per unit volume.

Mixture Control: **20**, **39**, 100

Allows manual metering of fuel for controlling the fuel-vapor to air ratio to the engine. Full out position shuts off all fuel to the engine at the carburetor. Full in position allows a pre-set maximum fuel quantity metering into the carburetor. Very low-density (high-altitude) operation requires manual reduction of fuel (leaning) for all engine operation.

Moment: **12-13**, 25-26, 35, 38, 69, 71

The tendency of a force to cause a body to rotate about a point and defined as the product of the force (F) and the **moment arm** (distance).

Momentum: 15-17, 20, 26, **33**, 90, 120

Intensity of motion; product of a mass and its velocity. The tendency to maintain motion until acted upon by other force.

Normal Attitude Flight: **180**

The close association of normal or usual flight attitudes leads the pilot often to consider both pitch and angular attitudes as the same. The vast majority of flight is within a range of less than 15 degrees nose up or down to the relative-wind and less than 45 degrees bank from horizontal.

Operation within these parameters makes it seem that there is little if any difference. Most pilots have learned flying using the terms interchangeably. This situation has also evolved in most writing as if they are the same. One should clearly state the type when referring to pitch.

Outward: 3, 8, 17, 40,

A direction away from the aircraft.

Overshoot: 67-68, 73-74, 79, 87, 106

Maneuvering beyond a desired track, as inadvertent tracking past the extended centerline when turning to roll out on final approach.

Pattern (airport traffic): 60, 65, 67, 70, 78-79, 89, 92, 119

Rectangular Traffic pattern; Standard course flown around an airport for traffic separation and control of takeoff, approach, and landing aircraft.

Performance: 16, 18-20, 29, 57, 73, 80, 95, 98, 100

Aircraft operation and maneuvering as related to structural and power capability.

P-Factor: 81

When other than longitudinally level, the propeller blades have different lifts. In a climb, the descending blade has greater lift causing left turn tendency.

Pitch: 11, 21, 24-25, 27, 34, 37,39, 43-44, 49-52, 55, 57, 60, 66-68, 70, 73, 77-78, 83, 88, 95, 102-104, 107-108, 116

(n.)The longitudinal angled attitude of the aircraft relative the horizon.

(v.)The act of inputting to and away elevator control or engine thrust component-lift changing the attitude of the aircraft.

Pitch Angle: 25, 27, 41, 43, 45, 55, 60, 67

The angle measured from the horizon to the static longitudinal axis. The angular profile attitude of the static longitudinal axis relative to the horizon.

Pitch Attitude: 24, 37, 40, 55, 102

The attitude of an aircraft as viewed in profile between the dimensional longitudinal axis and a horizontal reference. Terminology often calls for pitch up or down as related to the surface, which is pitch angle.

In space, pitch occurs to or away from the pilot. This allows understanding the results of pitch change no matter the attitude. Attitude relative to the pilot is "Aircraft Pitch"

Attitude”. Within the cockpit up is toward the top of the aircraft. Elevator-pitch control will be to or away relative to the pilot. If flying inverted increasing pitch to/up would cause the aircraft to go down toward the earth!

Pitch Axis: 181

The lateral or transverse rotational axis through an aircraft. Also called the pitching axis.

Pitch, Climb: 34, 44, 102, 107

The increased attitude angle resulting from changed direction of motion caused by excess-thrust component-lift and sustained by the excess-thrust component-forward.

Pitch Control: 11, 21, 27, 34, 37-38, 43-44, 49-50, 52, 61, 78, 86, 88, 93, 102-108, 111-112, 114, 123-124

Pitch Control is affected by forward or aft control wheel input to the elevator or horizontal stabilizer, the elevator trim wheel, and engine power changes. Changed downwash over the tail from power changes can affect elevator-pitch trim on some aircraft.

Pitch, Moment: 181

A force around the effective center of pressure (load) produces a moment. The fuselage acts as the arm for the horizontal stabilizer, elevator, and engine pitching forces moving the aircraft nose to or away relative to the pilot.

Pitch, Thrust-component: 181

The thrust component-lift at the engine attachment with a moment arm to the center of lift.

Pitch Up: 49 77, 83, 107-108

Relates to controlling the airplane with power, configuration change, or elevator input, and is relative to the pilot in the aircraft. This is a relationship of the airplane's attitude, input of pitch control, (elevator or power change) and the indicated-airspeed (angle-of-attack) the airplane wants to fly.

Manual elevator input changes aircraft pitch with a related change to the angle-of-attack and indicated-airspeed. Power changes cause increase or decrease of pitch from engine thrust component-lift, engine placement torque (moment away from centerline), propeller-blasting air, and/or wing downwash flow across the elevator.

Change in any one of these inputs can contribute to change of elevator trim. A pilot must always consider these criteria when

checking out in any specific aircraft to enable understanding control response when changing power input and configuration.

Pitot: 27-28

A forward facing, open-ended, tube, rammed with the mass-of-the-air from forward motion of flight used for measuring indicated-airspeed pressure.

Power: 1, 4, 17-21, 25-26, 29, 33-52, 55-61, 65-81, 87-88, 91-114, 117, 121, 123, 128

Time rate of work. Transfer of energy in a direction of motion over time. Power transferred through the propeller accelerates air mass causing reactive thrust to cause and sustain the aircraft motion.

Pressure: 1-2, 5, 8, 15-16, 20-22, 27-29-30, 48, 95-96, 99-100, 105,
The reaction to a force, measured in unit area.

Pressure Altitude: 29

The altitude in a standard atmosphere. The standard barometric pressure is 29.92 inches of mercury, 1013.25 hPa.

Profile Drag: 182

Wind Resistance. Caused by motion of the aircraft impaction and displacement of the airstream, increases with increased indicated-airspeed.

Propeller (prop): 1, 16, 19, 24, 37, 46, 81-82, 91, 95

Fan device attached to an engine for generating thrust.

Propeller-blast (prop-blast, prop-wash): 12, 37, 44, 58, 75, 78, 80, 88, 91-93, 107

Rearward accelerated air mass caused by propeller rotation and affecting the horizontal stabilizer and areas behind the aircraft.

Ram Air Pressure: 182

The dynamic pressure created by forward motion into the free-stream air.

Real Wind: 28, 30, 75

Surface Wind, The horizontal movement of an air mass across earth's surface.

Relative Wind: 45, 49, 82

The encountering of the free-stream air. Movement generated wind opposite the direction of the aircraft motion. A wind of motion.

Roll: 24, 28, 33, 36-37, 47, 57, 68, 80, 92-93, 98, 113, 127

1. Banking/Roll: Changing the aircraft attitude away from or to wings level flight.
2. Aircraft motion on the ground.

Roll/Bank in/out: 36,

Inflight maneuvering for turns. Roll into a turn is inputting control by banking the wings away from horizontal.

Roll out of a turn is inputting control to return to wings level horizontal).

Rollout: 80, 85, 87-88, 91-93

1. The landing roll after touchdown until stopping or slowed for turnoff of the runway.
2. Reducing banking in turns to resume wings level flight.

Rotation: 12,15, 23-24, 38, 44, 83

The act of turning as around an axis, the pitching and banking of attitude.

The pitching up at specific indicated-air speeds for takeoff, Vr.

Roundout: 61, 75, 80, 86-87, 106, 119, 123-124

Leveling, with gradual manual back elevator when a few feet above the ground for a landing. This causes reduced descent rate and slowing as the angle-of-attack increases.

Rudder: 13, 22, 24, 26-27, 33-37, 44, 52, 56, 61-62, 68, 72, 75, 81-82, 85-88, 90-92, 94, 106, 108, 110, 113, 120, 127

A flight control for causing yaw/rotation around the aircraft vertical axis steering the direction of engine thrust. Attached to the trailing edge of the vertical stabilizer the rudder swings left or right into the airstream with input by the pilot's feet to the rudder pedals creating aerodynamic force sideways yawing the tail.

Runway: 30-31, 34, 56, 62-64, 69-75, 77-79, 81-82, 85, 87, 89-98, 102, 110, 114

An area used for airplanes to take off and land.

- Scan: 184**
Outside; visually searching the total area around for unknown or conflicting traffic.
Inside; visually checking and confirming instrument readings.
- Setting a Directed-Course: 184**
Maneuvering flight toward a sighted point by maintaining it unmoving relative a point on the windshield, a collision course.
A technique for determination of a Directed-Course can be by visually sighting or physically pointing a finger at the object or destination and maneuvering the aircraft attitude such that the object or destination is fixed, unmoving, relative to that point on the window.
- Short-field: 83, 85, 87-88, 98, 106, 119**
A departure area limited in length to that required to attain takeoff indicated-airspeed.
- Sight Picture: 50, 53-62, 70-71, 75-7, 89, 112**
The pilot's view of the horizon and points on the horizon and ground used as reference toward which directing visual flight.
- Skid: 75, 90**
Ground; skidding, sideways travel of tires on the surface.
Airborne; skid is the opposite of slip, too much rudder steering input with too little turning causing the aircraft to slide (skid) away from the turn.
- Slip: 61, 72-75, 81, 85-86, 118, 124**
Uncoordinated attitude of a turn by input of opposite directed rudder causing the aircraft to slide into the turn. Slip causes the aircraft to move sideways.
Forward-slip is a technique of cross controlling to cause added drag to increase rate of descent in the direction of motion.
Side-slip is a crosswind landing technique for having the wheels aligned with the direction of motion with rudder steering and opposite direction banking turn with aileron to counter crosswind drifting for centerline tracking control.
- Slipstream: 184**
The stream of air or fluid forced backwards by a propeller.
The area of reduced pressure and forward suction behind a fast-moving object.

Soft-Field: **87, 89, 91-92, 97, 123, 128**

Runway surface on which the aircraft may experience excess drag during takeoff and landing roll. Wet dirt, snow, tall grass etc.

Speed: **5,7, 27, 30, 50, 93, 119, 124**

Rapidity of motion. Time rate of change. Distance traveled over time, as miles per hour.

True Airspeed is motion within an airmass and relative only to velocity within that air mass.

Groundspeed is motion relative to the earth's surface.

Indicated-airspeed is measurement of the airmass pressure encountered, not a speed at all!

Spiraling Slipstream: **81**

The spiraling airflow from the turning propeller contacts the left side of the rudder causing a left turning tendency.

Stability: **17 25, 35, 51**

The tendency of a system to retain its position or attitude, or if displaced, to return to that position or attitude.

Stabilizer: **1-3, 13, 25, 35, 37-38, 44, 48, 56-57**

Airfoils normally attached horizontally to the tail for aircraft pitch stabilization and control.

Stall: **11-12, 21, 25-26, 38, 47, 51, 58, 60-62, 66-68, 72, 88, 101-116, 118, 120-125**

The condition of exceeding wing critical angle-of-attack, the disruption of lift, and the aircraft begins falling.

Pilot input forcing an angle-of-attack such that laminar airflow over the wing separates causing failed aerodynamic lift.

Static: **13, 23-24, 88 109**

Unmoving, stationary position.

Steer: **5, 21-22, 24, 26, 33-37, 41, 43-44, 53, 61-62, 72, 75, 81-88, 90-94, 106, 120-121, 124, 128**

Directing thrust of the aircraft with brakes and flight controls.

Structural: **13, 40, 48, 50**

Components of the aircraft that transport, transmit, or carry forces and loads.

Strut: **185**

Device to brace or support different parts of a machine to each other; wing strut, landing gear strut.

Surface Wind: 186

Real Wind; the horizontal movement of an air mass relative the earth.

Sustaining Thrust: 20-23, 27, 35, 41, 44-45, 49, 51, 70, 96-100, 103, 107

The thrust required at a chosen altitude and indicated-airspeed to sustain wings level flight.

Tail: 11-12, 24-26, 35-38, 80, 93, 107

Aft portion of the fuselage to which the horizontal and vertical stabilizers are attached, the empennage.

Tailwind: 85, 91

That component-vector of air mass movement (real wind) in the direction of flight.

Takeoff Distance: 186

The distance required from brake release to becoming airborne and clear a known obstacle beyond the end of the runway. Takeoff distance when considering clearing a 50-foot obstacle at some distance beyond the field.

Takeoff Power: 81-82, 92, 94

1. Command setting engine power for takeoff.
2. Engine power setting used for takeoff from the runway.
3. Command for reducing engine power.

Takeoff Roll: 28, 33, 82-83, 98

Distance of runway travel required to become airborne.

Taxi: 33, 37, 62, 75, 81-82, 86, 88, 91, 93

Maneuvering of the airplane on the ground. When the aircraft is on the ground, its control is not unlike that of an automobile. The main difference is steering is done with the feet and power controlled with the hands. All maneuvering on the ground, Taxi, Takeoff Roll, and Landing Roll control is in this manner. Control of the engine power causes the thrust for motivation and resulting speeds on the ground. Foot operated wheel brakes control deceleration and aid steering.

Temperature: 18, 28-29, 95, 99

Measurement of heat energy

Throttle: 19-20, 27, 33, 39, 41, 49, 81, 99-100, 107

Allows Pilot manual adjustment of power by control of airflow through the carburetor. Controls the power output and resultant thrust to allow motion and acceleration to attain and sustain ground maneuvering and flight. Pushing the throttle full forward/in results in maximum power output. Pulling the throttle away/out reduces the engine power output. Pushing in causes increased power. Full out is idle position.

Thrust: 1-6, 8, 11-13, 16-17-22-27, 33-52, 57-58, 60, 65-66, 68-70, 78, 81, 95, 100-103-104, 107, 111, 115-116, 128

A reactive force forward from large quantities of air mass movement exerted by a propeller (blasting air) or directed burning fuel of a jet engine (expanding gases) for creating motion.

Gravity component-forward with descent.

Thrust Components: 40

The reactive thrust forces acting from a thrust source in directions ninety degrees away from each other, a main force forward in direction of motion and a smaller force away at the top at attachment as lift.

Tie Down: 93

Anchor in the ground for a rope or chain to secure a parked aircraft.

To or Away (toward/from): 44

Pull and push of elevator control causing aircraft pitch change up or down relative the aircraft, not the earth.

Torque: 13, 81

Turning force opposite rotation, tending to rotate at an axis. On an aircraft, it results in left turn tendency.

Touchdown: 30-33, 37, 54, 61-62, 67, 70, 72-73, 75, 79-80, 82-87-88, 90-93, 106, 110, 118-124-126

Instant of wheel contact with the surface upon landing.

Touchdown spot/point/area: 67, 75, 72, 79-80, 85-88, 123-124

Visually sighted chosen landing spot for Directed-Course approach. Also called approach aim point.

Traffic Pattern: 60, 65, 67, 78-79, 89

The Standard VFR/VMC traffic pattern is a rectangular flight path around a landing area using left turns. The entry to

downwind is a 45-degree heading intercept to the downwind direction. Non-standard traffic patterns use right turns.

Track: **28**, 61-62, 68, 71, 73, 75-76, 79, 81-82, 86, 89-90, 92
Planned or actual course/route/path of movement across or relative to the surface of the earth. The actual path over the surface (ground track) followed, or intended to be followed.

Trim: 28, 33, **38**, 41, 44-45, 49, 51-52, 56-57, 61, 66, 68, 70, 78-82, 89, , 102-**107**, **115**-116, 118, 121-124, 127-128,
Adjustment of small airfoils on the flight control surfaces (yaw, roll, and pitch) to coordinate and balance control input to a neutral position for steady state flight with minimum pilot input.

True Airspeed: **28-29**, 41, 96,
Rate of travel within and relative to the specific air mass.

Turn: **13**, 20, 24-**26**, 34, 36, 46-**47**-48, 52-53, 57-58, **67**-71, 73,75, 79, 90, 94-95, 104-106, 114, 127-128
When rolled into a banked attitude, the total wing lift becomes at an angle relative to gravity. Roll results in causing a horizontal component of aerodynamic and engine thrust component-lift that changes heading (direction of motion) causing turn.

Turn Control: **188**
Coordination of Aileron, Rudder and Thrust input is required to roll into an attitude away from wings level. The aerodynamic lift vector changes direction so reduces the vertical-component lift and begins generating horizontal component-lift that causes heading change. For maintaining level flight, constant indicated-airspeed, added power for additional lift is required.

Up: **17**, 20, 23, 33, 39, 41-45, 51, **57**, 60-62, 74-75, 77, 79-80, 83, 86-87, 91, 96, 99, 102-103, 107-112, 116126
A direction increasing the vertical distance from the earth's surface.
To the Pilot within the aircraft, a direction out the top.

Upright: **188**
Aircraft attitude with lift forces orientated away from the surface.

Upward: **6-8-9**, 29, 48, 70, 95, 114
Directing increased distance from the earth's surface.

Within an aircraft, direction away from the top.

Vector (Flight): 189

When controlling flight; a direction or heading assignment.

Vector (Force): 3, 21

A quantity of force possessing both magnitude and direction describing the reaction to power and gravity (energy) input.

Vector-Component (Force): 3,

A related directional force when dividing a force vector into components acting 90° to each other. The force F has related directional components, F_y and F_x , 90° to each other. Component vectors represent separate forces which when exerted in their specific directions result in a reactive force F . Example; if $F_y = .866$ lb. and $F_x = .5$ lb. Trigonometrically adding the two vector forces results in a resultant vector force $F = 1$ lb. angled thirty and sixty degrees between the two.

Velocity/Speed: 3, 6-8, 10, 17, 21, 27-30, 33, 40, 82, 96-97, 100, 108-109, 121, 123

Rapidity of motion. Time rate of change relative a reference. Distance traveled over time, as miles per hour.

Vertical: 1-2, 4, 18, 21, 24, 26-28, 36-38, 43-44, 46-47, 50, 52, 55, 57, 61-62, 88, 91, 96, 109-110, 114, 121, 123

Direction to or away from the earth. Away from the earth is positive and to is negative.

Vertical Axis: 24

The line of rotation perpendicular to the longitudinal axis and transverse axes passing through the center of pressure.

Vertical Component of a Force: 1-2, 4, 18, 21, 28, 36, 38, 46, 57

A force or component force directed upward away from the earth.

Vertical Lift: 4, 21, 23, 26, 36-37, 46, 50, 57

The component-lift forces out of the aircraft directed away from the earth.

Vertical Stabilizer: 37

Small aerodynamic airfoil normally mounted vertically on the tail (empennage) for directional stabilization. An attached rudder allows yaw control for side-pitch steering control.

Visual Directed Flight: 25, 52-53-55, 60-61, 65-70-72, 74, 77-79, 82-83, 85, 90, 95, 98, 119-120, 123-124, 127

Flight control using sighting of the horizon and distant objects as reference for attitude.

Volumetric Displacement: **190**

The aircraft moving through an air mass creates flow of the air relative to the machine. There is continual displacement of a volume of air away from the frontal area as it encounters the free-stream air. This displacement changes direction of this relative airflow with resulting retarding frictional drag forces and reactive lifting forces.

V_a (maximum indicated-airspeed in turbulence): **190**

The maximum airspeed for turbulence. For a typical light civilian aircraft, V_a will be approximately double V_s , to ensure that the plane will stall under acceleration greater than 0 g (0 m/s^2).

V_c (Optimum Cruise) **190**

Attained by dividing V_y by .75, equivalent to 1.3 times V_y

V_{fe} (maximum indicated-airspeed for extending flaps): **190**

Maximum airspeed for flap extension.

V_{me} (Loiter): **25, 46, 74, 1118**

Maximum Endurance; Indicated-Airspeed at which the aircraft will remain airborne the longest time. Attained by multiplying V_y by .75.

V_{ne} (never exceed indicated-airspeed): **190**

Airspeed if exceeded may result in structural failure (red line).

V_{no} (maximum indicated-airspeed for cruise): **190**

Maximum structural cruising speed, to be exceeded only in very calm air (yellow line).

V_s (clean configured stall): **190**

The aircraft's stall speed in clean, or cruise, configuration (gear and flaps up).

V_{so} (landing configured stall): **190**

The aircraft's stall speed in dirty, landing, configuration (gear and flaps down).

-
- V_x** (maximum climb indicated-airspeed): **5, 83, 98**
Indicated-airspeed at which the aircraft gains the most altitude in a given distance. Used for maximum climb rate such as clearing obstacles etc.
- V_y** (optimum climb indicated-airspeed): **5-6, 12, 18-21, 29, 38, 44-47, 70, 98, 100-101, 103**
Indicated-airspeed at which the aircraft gains the most altitude in a given time (best rate of climb). This results in the most fuel-efficient over time indicated-airspeed for all operation in-flight. Note: An increase in indicated-airspeed from V_y will require increased thrust input for continued level flight.
- Wake:** **108, 110**
Mixed airflow left behind as caused by the disturbance of aircraft airmass displacement.
- Wake Turbulence:** **108-109-110**
An aircraft displacing air leaves continued turbulent airflow behind. When encountering this disturbed air, a following aircraft surfaces will have random changed airflow causing rapidly changing lift pressures, resulting in erratic or possibly uncontrolled flight.
- Weather:** **85, 92-93, 98, 127**
Atmospheric conditions of wind, temperature, and humidity.
- Weathervaning:** **82, 91,**
Turning into the wind caused by a crosswind component of wind force pushing the large side area of an aircraft aft fuselage during landing rollout and taxiing.
- Weight:** **1-7, 11, 15, 17, 19, 26, 28, 34, 36, 46, 50, 71, 85, 95-96, 101-102, 111, 115**
The force exerted on mass by gravity and always directed toward the earth. A measure of gravitational effect on a mass. The acceleration of gravity as it affects an aircraft is equivalent to a thrust force toward the surface of the aircraft's weight.
- Wind (air mass):** **28, 96, 108**
The motion of an air mass measured at a specific altitude as referenced to the surface.
- Wind (Surface, real):** **28, 31-32, 68, 71, 75, 82, 88-93, 110**
Air mass movement referenced at the earth's surface.

Wind component: **31-32**, 75, 80, 85, 91, 109

A component-vector of air mass movement as related to a specific direction (i.e., runway or flight heading) being considered.

Wind Effect Correction: **85-86**, 88, 91, 95

A heading (correction) turned toward/into any air mass movement to enable maintaining a specific (desired) ground track. (drift correction).

Wind of Motion: **11**, 45, 49, 102

A relative wind. The movement generated wind from motion through an air mass and always in the opposite direction of that motion.

Wind Resistance: **192**

Frontal Profile displacement pressure and friction drag effects.

Windshield, Windscreen: **50**, 53-61, 63, 67, 71-72, 74-76 83, 118-119, 123-124

The front window, a forward facing window for shielding from wind and debris.

Wing: **2-3**, 6-12, 21-26, **29-30**, 36-37, 40, 48, 58, 67, 76, 82, 91, 101-104, 107-108, 110-111, 114, 120

The structural components attached to the fuselage of an aircraft, composed of large surfaces for generation of aerodynamic lift.

Wing Angle-of-attack: **11**, 21, 25, 29, 40, 58, **102**, 104-105, 107, 111,

The angle between the wing center chord and direction of the relative wind. The angle measured from the direction of motion (relative wind) to the dimensional longitudinal axis plus any angle of incidence.

Wing Chord: **11**

Line between wing leading edge and trailing edge.

Yaw: **23-24**, 34, 36-37, 53, 90

Motion about the vertical axis (fishtailing. side to side motion), controlled with rudder pedal, steering the direction of engine thrust for coordinating the various turning forces involved.

Zoom: **16-17**, 26, 45, **51-52**, 70

The action of increasing angle of attack; pitching to gain altitude using kinetic energy of the aircraft momentum.

