

# **THE TECHNICIANS NOTEBOOK**

**By Jerry Gordon**

## The Technician's Notebook Table of Contents

<b>200/300A A/P</b>	<b>4</b>
<b>ADF 141</b>	<b>7</b>
<b>ADF 650A</b>	<b>9</b>
<b>AT 50A</b>	<b>10</b>
<b>COM 810/811</b>	<b>12</b>
<b>DME 451</b>	<b>13</b>
<b>DME 890</b>	<b>15</b>
<b>IN 385/386</b>	<b>16</b>
<b>KI 201C/KI 214</b>	<b>18</b>
<b>KI 208/KI 209/KI 208A/KI 209A</b>	<b>19</b>
<b>KLX 135/KLX 135A</b>	<b>22</b>
<b>KMA 20</b>	<b>24</b>
<b>KMA 24</b>	<b>26</b>
<b>KN 62/KN 64</b>	<b>28</b>
<b>KN 65/KN 65A</b>	<b>31</b>
<b>KN 72/KN 77</b>	<b>35</b>
<b>KN 73/KN 75</b>	<b>36</b>
<b>KNS 80</b>	<b>37</b>
<b>KR 85</b>	<b>40</b>
<b>KR 86</b>	<b>42</b>
<b>KR 87</b>	<b>45</b>
<b>KT 76C</b>	<b>48</b>
<b>KT 79</b>	<b>49</b>
<b>KX 125</b>	<b>51</b>
<b>KX 145</b>	<b>53</b>
<b>KX 155A</b>	<b>55</b>
<b>KX 155/KX 165</b>	<b>57</b>
<b>KX 170B</b>	<b>61</b>
<b>KY 196/KY 197</b>	<b>61</b>
<b>MARK 12D</b>	<b>68</b>
<b>NAV 11/NAV12</b>	<b>70</b>
<b>NAV 121/NAV 122/NAV 124</b>	<b>71</b>

## The Technician's Notebook Table of Contents (Continued)

<b>R 346A/R 546E</b> -----	<b>73</b>
<b>R 402A</b> -----	<b>75</b>
<b>R 443B</b> -----	<b>77</b>
<b>RT 308/RT 328</b> -----	<b>79</b>
<b>RT 359A/RT 459A</b> -----	<b>82</b>
<b>RT 385A/RT 485A</b> -----	<b>85</b>
<b>TDR 950</b> -----	<b>91</b>
<b>TERRA BY TRIMBLE</b> -----	<b>93</b>
<b>VHF 251</b> -----	<b>97</b>
<b>VIR 351</b> -----	<b>99</b>

# The Technicians Notebook

By Jerry Gordon

## 200/300A A/P

Revision No: 1 11/1995

Weight: CA-295B 1.5 lbs, CA-395A 1.8 lbs.

G-300A 2.5 lbs, G-300B 1.4 lbs, PA-295B 5.7 lbs, PA-495A 3.9 lbs.

G-502A 3.4 lbs, G-502B 4.4 lbs, IN-502A .2 lbs, CT-502A .6 lbs.

Parts Numbers: Panel; Narrow gray 51321-00010, Wide gray 51321-00030

Wide black 51321-00050, Block (locking panel) 30315-00000

Switch S4 (with caps) 42030-00000, Switch S4 (without caps) 42030-00010, Caps 42030-00020

### SERVICE BULLETINS:

AV 76-1 H-42 Test set corrections to service/parts manual.

AV 78-1 CA-395 Computer input voltage line filtering.

AV 78-16 H-42 Modification for use with DC computers.

AV 79-22 CA-395 Power circuit improvements

AV 79-30 300A A/P with IG-832C HSI difference information.

AV 80-5 200/300 A/P duty cycle limits. See following tables:

CA-395A DUTY CYCLE LIMITS

CA-395A Part No.	Cessna Aircraft Model	Adjust (Rate Gyro in Right SRT)		Check (Rate Gyro in Left SRT)	
		Percent Duty Cycle	DC Volts (TP11)	Percent Duty Cycle	DC Volts (TP11)
42660-1000	All 14 V Single Engine	70 ± 2%L	-1.12V ± 120mV	49 ± 6%R	+0.8 V ± 100mV
42660-*20*	172	70 ± 2%L	-1.13V ± 120mV	70 ± 7%R	+1.13V ± 120mV
	R172	70 ± 2%L	-1.13V ± 120mV	70 ± 7%R	+1.13V ± 120mV
	RG172	70 ± 2%L	-1.13V ± 120mV	70 ± 7%R	+1.13V ± 120mV
	B177	55 ± 2%L	-0.96V ± 120mV	55 ± 6%R	+0.96V ± 120mV
	RG177	70 ± 2%L	-1.13V ± 120mV	70 ± 7%R	+1.13V ± 120mV
	180	80 ± 2%L	-1.26V ± 120mV	80 ± 8%R	+1.26V ± 120mV
	182	75 ± 2%L	-1.20V ± 120mV	75 ± 8%R	+1.20V ± 120mV
	R102	75 ± 2%L	-1.20V ± 120mV	75 ± 8%R	+1.20V ± 120mV
	TR182	75 ± 2%L	-1.20V ± 120mV	75 ± 8%R	+1.20V ± 120mV
	185	100 ± 2%L	-1.46 ± 120mV	100 ± 2%R	+1.46V ± 120mV
	206	70 ± 2%L	-1.13 ± 120mV	70 ± 7%R	+1.13V ± 120mV
	T206	70 ± 2%L	-1.13 ± 120mV	70 ± 7%R	+1.13V ± 120mV
	207	70 ± 2%L	-1.13 ± 120mV	70 ± 7%R	+1.13V ± 120mV
	T207	70 ± 2%L	-1.13V ± 120mV	70 ± 7%R	+1.13V ± 120mV
	210	85 ± 2%L	-1.33V ± 120mV	85 ± 8%R	+1.33V ± 120mV
	T210	85 ± 2%L	-1.33V ± 120mV	85 ± 8%R	+1.33V ± 120mV
42660-*20*	P210	85 ± 2%L	-1.33V ± 120mV	85 ± 8%R	+1.33V ± 120mV

CA-295B DUTY CYCLE LIMITS

CA-295B Part No.	Cessna Aircraft Model	Adjust (Rate Gyro in Right SRT)		Check (Rate Gyro in Left SRT)	
		Percent Duty Cycle	DC Volts (TP11)	Percent Duty Cycle	DC Volts (TP11)
43610-1000	All 14 V Single Engine	70 ± 2%L	-1.32V ± 120mV	49 ± 6%R	+0.8 V ± 100mV
43610-120*	172	65 ± 2%L	-1.05V ± 120mV	65 ± 7%R	+1.05V ± 120mV
	R172	70 ± 2%L	-1.13V ± 120mV	70 ± 7%R	+1.13V ± 120mV
	RG172	70 ± 2%L	-1.13V ± 120mV	70 ± 7%R	+1.13V ± 120mV
	B177	70 ± 2%L	-1.13V ± 120mV	70 ± 7%R	+1.13V ± 120mV
	RG177	70 ± 2%L	-1.13V ± 120mV	70 ± 7%R	+1.13V ± 120mV
	180	80 ± 2%L	-1.26V ± 120mV	80 ± 8%R	+1.26V ± 120mV
	182	70 ± 2%L	-1.13V ± 120mV	70 ± 7%R	+1.13V ± 120mV
	R182	70 ± 2%L	-1.13V ± 120mV	70 ± 7%R	+1.13V ± 120mV
	TR182	70 ± 2%L	-1.13V ± 120mV	70 ± 7%R	+1.13V ± 120mV
	185	90 ± 2%L	-1.36V ± 120mV	90 ± 9%R	+1.36V ± 120mV
	206	70 ± 2%L	-1.13V ± 120mV	70 ± 7%R	+1.13V ± 120mV
	T206	70 ± 2%L	-1.13V ± 120mV	70 ± 7%R	+1.13V ± 120mV
	207	70 ± 2%L	-1.13V ± 120mV	70 ± 7%R	+1.13V ± 120mV
	T207	70 ± 2%L	-1.13V ± 120mV	70 ± 7%R	+1.13V ± 120mV
	210	85 ± 2%L	-1.33V ± 120mV	85 ± 8%R	+1.33V ± 120mV
43610-120*	T210	85 ± 2%L	-1.33V ± 120mV	85 ± 8%R	+1.33V ± 120mV

200A NAVOMATIC ACTUATOR-MOUNTS

Cessna Model	Part No.	Gear Ratio	Voltage	Nominal Stall Torque	Cable Tension
172M	43600-2004	2:1	14V	17 in/lb ±15%	10 +3 lbs.
F172M	43600-2004	2:1	14V	17 in/lb ±15%	10 +3 lbs.
FR172J	43600-3004	3:1	14V	25 in/lb ±15%	10 +3 lbs.
177B	43600-1004	1:1	14V	9 in/lb ±15%	10 +3 lbs.
177RG	43600-1004	1:1	14V	9 in/lb ±15%	10 +3 lbs.
F177RG	43600-1004	1:1	14V	9 in/lb ±15%	10 +3 lbs.
180J	43600-3004	3:1	14V	25 in/lb ±15%	10 +3 lbs.
A185F	43600-3004	3:1	14V	25 in/lb ±15%	10 +3 lbs.
182P	43600-3004	3:1	14V	25 in/lb ±15%	10 +3 lbs.
U206F	43600-3004	3:1	14V	25 in/lb ±15%	10 +3 lbs.
U206F	42730-4008	4:1	28V	26 in/lb ±15%	10 +3 lbs.
TU206F	43600-3004	3:1	14V	25 in/lb ±15%	10 +3 lbs.
TU206F	42730-4008	4:1	28V	26 in/lb ±15%	10 +3 lbs.
207	43600-3004	3:1	14V	25 in/lb ±15%	10 +3 lbs.
207	42730-4008	4:1	28V	26 in/lb ±15%	10 +3 lbs.
T207	43600-3004	3:1	14V	25 in/lb ±15%	10 +3 lbs.
T207	42730-4008	4:1	28V	26 in/lb ±15%	10 +3 lbs.
210L	42730-2008	2:1	28V	14 in/lb ±15%	10 +3 lbs.
T210L	42730-2008	2:1	28V	14 in/lb ±15%	10 +3 lbs.

### 300A NAVOMATIC ACTUATORS

Cessna Model	Part No.	Gear Ratio	Voltage	Nominal Stall Torque	Cable Tension
172M	43600-2004	2:1	14V	18 in/lb ±15%	10 +3 lbs.
F172M	43600-2004	2:1	14V	18 in/lb ±15%	10 +3 lbs.
FR172J	43600-3004	3:1	14V	27 in/lb ±15%	10 +3 lbs.
177B	43600-1004	1:1	14V	9 in/lb ±15%	10 +3 lbs.
177RG	43600-1004	1:1	14V	9 in/lb ±15%	10 +3 lbs.
F177RG	43600-1004	1:1	14V	9 in/lb ±15%	10 +3 lbs.
180J	43600-3004	3:1	14V	27 in/lb ±15%	10 +3 lbs.
A185F	43600-3004	3:1	14V	27 in/lb ±15%	10 +3 lbs.
182P	43600-3004	3:1	14V	27 in/lb ±15%	10 +3 lbs.
U206F	43600-3004	3:1	14V	27 in/lb ±15%	10 +3 lbs.
U206F	42730-4008	4:1	28V	24 in/lb +1 in/lb	10 +3 lbs.
TU206F	43600-3004	3:1	14V	27 in/lb ±15%	10 +3 lbs.
TU206F	42730-4008	4:1	28V	24 in/lb +1 in/lb	10 +3 lbs.
207	43600-3004	3:1	14V	27 in/lb ±15%	10 +3 lbs.
207	42730-4008	4:1	28V	24 in/lb +1 in/lb	10 +3 lbs.
T207	43600-3004	3:1	14V	27 in/lb ±15%	10 +3 lbs.
T207	42730-4008	4:1	28V	24 in/lb +1 in/lb	10 +3 lbs.
210L	42730-2008	2:1	28V	14 in/lb ±15%	10 +3 lbs.
T210L	42730-2008	2:1	28V	12 in/lb ±15%	10 +3 lbs.
337G	42730-4008	4:1	28V	24 in/lb +1 in/lb	10 +3 lbs.

**AV80-32 and AV80-40 Tech Aid No. 115** Replace all germanium diodes (1N270) with silicon diodes (1N458 P/N 326890005). This applies to A1CR1 through A1CR11, A7CR6, and A7CR7. The exception to this is A1CR3 as per AV80-40. Use the germanium diode (1N270 P/N 344100000) for this application.

**AV80-34 Power circuit improvements.** Tech Aid No. 108 Installation of 10k resistor (PN 003410103) A2R4. If A2U2 is replaced on any CA-395A, A2R4 should be installed if it is not. Verify that capacitor A2C6 has been deleted as per Tech Aid No. 74. If not remove and discard. Install A2R4 as per drawing.

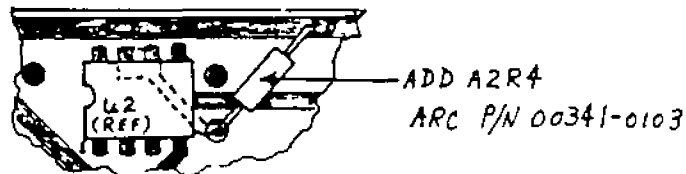
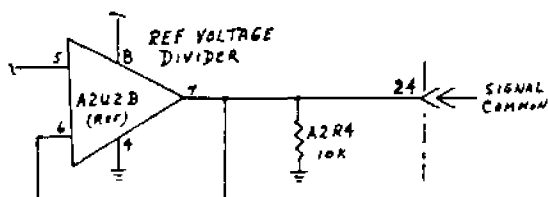

**• FOLLOWING COURTESY OF SIGMA-TEK CUSTOMER SERVICE:**

1. If CA-395A passes final test, but still does not operate in aircraft. Check P122 (servo + 28 VDC), controlled by on/off switch on front panel. This is not covered in final test, and should be checked.
2. Lamp replacement in panel. The easiest way we've found to replace lamps if the knobs are glued on is to take the screws out of the lamp holders, take lamp holders out far enough to replace lamps, then put lamp holders back in. We've found this to be easier than taking the switch and panel assembly off.

**NOTES:**

# The Technicians Notebook

By Jerry Gordon

# ADF 141

Revision No: 1 11/1995

Panel Unit weight 2.1 lb.. Tray weight .5 lb..

ADF 101 Indicator weight 1.0 lb.. RMI-101 Indicator weight 1.6 lb..

Loop Antenna weight 1.6 lb.. Antenna Coupling Adapter weight .2 lb..

Frequency coverage 200-1799 Khz in 2 bands. Audio output 50 mw in 500 ohms.

70 uv/m ANT for 6 DB S+ N/N 1 Khz mod 30%, 150 uv/m ADF for 6 DB S+ N/N 1 Khz mod 30%.

Quad Error adjust to 14 degrees, and meter zero adjustable through indicator bezel with screwdriver.

> 3 degrees accuracy at 70 uv/m between 200-850 Khz

> 5 degrees accuracy at 70 uv/m between 851-1799 Khz

Sense antenna capacitance 210 pf. Capacitance of sense cable + padder across pins 3 & 5 of J-501 must be 210 pf.

Capacitance Per Foot:

RG-58 A/U 28.5 pf/ft.

RG-59 U 21 pf/ft.

RG-62 A/U 13 pf/ft.

RG-114 6.5 pf/ft.

## TECH TIPS FROM NARCO:

- Power Supply

Check power supply for correct voltages. If problem exists in regulator circuitry, it is necessary to lift the collectors to ohm out the transistors. This regulator employs direct coupled transistors (collectors to bases) and cannot be ohmed in circuit.

- Synthesizer

With 1000 Khz set in frequency window check the output of the prescaler at the bases of Q502 and Q503 with a frequency counter. It should read 9.701 Mhz  $\pm$  350 Khz. If this is not correct, check Pin 1 of U403 (MC4044P frequency-phase comparator), it should read exactly 1 KHz. This is the reference channel for the frequency-phase comparator. If the frequency is wrong, adjust C422. To check the operation of VCO see Page 4-43, Section 4.7.3 of the ADF-141 maintenance manual.

- Receiver IF Section

To check the receiver IF for correct operation, inject a 10.7 Mhz carrier amplitude modulated at 1000 Hz at the junction of C501 and Pin 3 of T501. Set signal generator level to 100 microvolts. This should produce 1.5 V peak to peak audio at Pin 3 of U507. When checking this set the volume control approximately mid range.

- Receiver RF Section

The RF front end is swept-tuned. There are two RF amplifiers employed in the front end. Only one is active at any one time. Q504 is the FET RF amplifier for the low band (200-499 KHz). Q505 is the FET RF amplifier for the high band (500-1799 KHz) CR501 and CR502 control which amplifier is in operation. CR501 controls Q504 and CR502 controls Q505. To set the gain of the RF amplifiers adjust R532 to provide 2.8VDC at the junction of R525 and R527. To set the IF signal input from the double balanced mixer adjust R504 to 1.38VDC at the center tap of R504. To set the receiver agc monitor the junction of TP505, L518 and C544 and adjust R560 to 1.0 VDC with a 35 millivolt signal input at the sense antenna connector.

- ADF-101 Indicator Nav Amplifier

Connect scope to TP301. Set scope to 50 millivolts per centimeter. Step waveform should be 6 volts peak to peak. If this is incorrect, adjust the loop gain (R514) and the loop agc (R578) per the procedure on page 4-37 section 4.6.4. You must have the sense antenna adapter pictured on page 4-8, figure 4-3, to perform this adjustment. We have seen quite a few units in factory service where all that is wrong with the ADF is improperly adjusted loop gain and loop agc.

- Common Problems

A. Indicator tracks from 270 degrees to 90 degrees through 0 degrees okay. Will not track (dead) from 90 degrees to 270 degrees through 180 degrees. Check DS203 or R204 for an open condition.

B. Indicator tracks from 270 degrees to 90 degrees through 180 degrees but will not track 270 degrees to 90 degrees through 0 degrees. Check DS204 for an open condition.

"A" and "B" above can also be caused by a defective transistor in the meter amplifier complimentary transistor pairs.

C. CR402 and CR414 on SW402. If leaky, open or shorted can cause weak receiver because of improper selection of band pass filters in RF front end.

D. CR512 output satisfies one input of U506D op-amp. If CR512 leaky, can cause a 30 degree to 60 degree error in indicator.

E. Q520 failure can cause no-stow condition in the antenna mode.

F. CR514,517,512 can cause stow condition in ADF mode if defective.

G. Q509,Q510, Q511, Q512 loop tuning switches. Only one transistor should be on at any one time. Check the base voltages; .75VDC on the base indicates transistor is on. If more than one transistor is on, check CR404, 405, 406, 407, 408, 409, 410, 411, 413, 414 on SW402 with an ohmmeter. If leaky or open or shorted, replace. It is recommended that you remove the synthesizer to replace these diodes. Remember to dial 288 in the frequency window to avoid damage to the switch wafers. When reinstalling synthesizer make sure switch rotor does not touch the bushing on the tuning shaft. This will burn out the diodes because there is + 9VDC on the rotor of the switch.

H. Q522 and Q523 are FET switches that short out opposite coil in loop antenna. Example: When sampling E-W coil, N-S coil shorted out and vice-versa. Set scope to 2 milliseconds per division and 1 volt per centimeter. Compare waveforms on pins 1 and 2 of Q523 with that of Q522 they must be the same, otherwise a pointing error will result. Pulses should be 3 volts peak to peak and have 9 milliseconds between heading edges. It is important that the pulses on both FET's match very closely in amplitude and time. There should not be any distortion on the trailing edge of the pulses. If the waveforms are incorrect in any way, change both Q522 and Q523.

- **Indicator Error Compensation**

1. Top left mounting hole is quadrantal error adjustment. This is an electronic adjustment and should be made with loop box at 45 degrees.

2. Lower right mounting hole is indicator zero adjustment and should be made with loop box at 0 degrees. This is a mechanical adjustment.

3. Repeat steps 1 and 2 above until both settings are correct. Refer to page 4-18, section 4.4.3 of the maintenance manual for the correct procedure to make these adjustments.

- **Sense Antenna Coupler**

Check the center lead of the coax to the coupler for 9VDC. Shield of the coax is ground return. If 9 volts is there and unit is weak or points 180 degrees out on the low band, then change the FET in the coupler. This is the only active device in the coupler and realignment is not necessary. Be careful when changing the FET as it is a MOSFET, which can fail due to static electricity.

New Part # for the FET is 75561-0010.

**NOTES:**



# The Technicians Notebook

By Jerry Gordon

# ADF-650/A

Weight 3.0 lbs, including tray and connector. IND-650 .75 lb. IND-650A .66 lb. ANT-650A 2.25 lb.

Sensitivity: ANT mode: 70 uv/m @30% mod 1khz for 6db s+ n/n. ADF mode: 150 uv/m @30% mod 1khz for 6db s+ n/n.

Bearing accuracy: 70 uv/m = 3 degrees. Bearing speed: 7 seconds for 175 degrees.

Audio output: 50mw @500 ohms.

Revision No: 1, Oct 1994

## Service Bulletins:

**SB-1**(Applicable RCR-650 before sn 3558) Audio quality improvement. Addition of 1 cap and 1 resistor.

**SB-2**(Applicable RCR-650 before sn 3869) Improved BFO operation. Replacement of 5 components

**SB-3**(Applicable RCR-650 before sn 4700) Reliability of 10 volt regulator. Remove zener and replace with resistor.

**SB-4**(Applicable RCR-650 before sn 6001) Reduced needle activity. Addition of filter and component changes.

**SB-5**(RCR-650) Keyed carrier operation.

**SB-6**(Applicable RCR-650 before sn 9146) 28 volt systems with bearing error around 135 degree bearing.

**SB-7**(RCR-650) Decrease AGC recovery time.

**SB-1**(RCR-650A) Decrease AGC recovery time.

**SB-2**(RCR-650A) Improve ADF response time.

**SB-3**(RCR-650A) Needle drift with keyed carrier beacons.

## Service Information Letters:

**SIL 2-77** (RCR-650) Receiver IF and RF trouble shooting procedures.

**IF Section:** Lift one end of R419 and connect a 1uf bypass cap to U402-4 and ground. Using probe with 1uf and 1k resistor in series, inject 8 mhz @1khz mod 30% at U402-8 Monitor TP-1 with scope. Increase gen output until 300 mv p-p signal present at TP-1. Record level in -dbm. Remove the 1uf bypass cap from U402-4 and inject the RF at U402-4. Increase the gen until 300 mv p-p signal at TP-1 is present. Record the level in -dbm. The difference is the gain of U402. This should be approx 34 db. Inject the RF input at U401-4. Adjust the gen for 300 mv p-p at TP-1 as before. Record the level in -dbm. The difference between the previous reading and this reading is the gain of U401 in db. It should be approx 34 db.

**Balanced Mixer:** Injection at gate of Q801 should be at least 1.0 vrms using an rf voltmeter.

**Rf Amplifier:** Using probe with 1uf cap in series, inject 1000khz @1khz mod 30% at 100 uv to drain of Q503 drain. Set RCR-650 to 1000khz. Connect audio power meter to P1-7 (+) and P1-8 (-). Adjust volume control for middle scale indication on the audio power meter. Reduce the gen rf level until the audio power output decreases exactly 3db. This rf level should be 10uv or less. If greater than 10 uv, either the balanced mixer or FL401 has excessive loss. Note the rf level in the previous step. Move the rf probe to Q503 gate and adjust the gen rf level to obtain the same audio power indication as in the previous step. Q503 gain is the db difference between this rf level and that of the previous step. It should be 10 db or greater.

**Sense RF Amplifier:** Connect the probe with 1uf in series to Q401 drain. Set the RCR-650 and gen to 1000khz at 1khz mod @30%. With the audio power meter connected as before, start at 10 uv and reduce the rf level until the output decreases 3db. It should be less than 3uv. Move the rf probe to Q401 gate and adjust the rf level to obtain the same audio output as before. The difference between this rf level and the previous level is the gain of Q401. It should be 6db or greater.

**SIL 1-79** (RCR-650) Slow AGC response time in receivers with SB-5 installed.

NOTES:

# The Technicians Notebook

By Jerry Gordon

# AT-50/50A

Weight 2.3 lbs. Tray .45 lbs.  
Class 1 transponder Power AT-50 125 watts , AT-50A 250 watts nominal  
MTL -69 to -73 dbm  
Max altitude 30,000 feet

Revision 1 10/1995

AT 50A-1 Procedure for adjusting the transmitter power output.

AT 50A-2 (applicable before chassis CNG 218B & CNR 218B) Modification to minimize RFI. Install 6 ferrite beads (Part No. 11454-0001) on anode lead of cavity.

AT 50A-3 Field analysis of defective transmitter cavities. Check resistance from anode to ground.

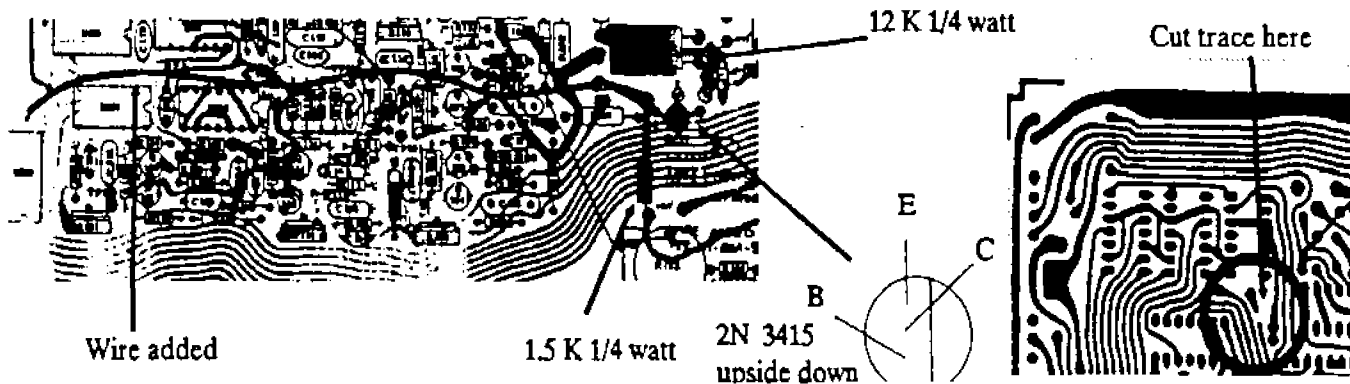

AT 50A-4 Description of changes to make units compatible with any altitude encoder. (see S.B. 5)

AT 50A-5 (applicable before chassis CNG 218B4 & CNR 218B4) This mod will make the unit compatible with all altitude encoders.

AT50A-6 Schematic update for service manuals.

AT50A-7 (starting with chassis CNG-218D) The AT50A now use the AT150 main pc board. Uses the AT 150 manual except for the trim panel area. To change the switch board assy, (Part No. 56262-0102) remove pins 7 & 14 (R to L) (See SB-9)

AT50A-8 Contains updated pages.

AT50A-9 Part number change for AT50A switch board assy. The new no. is 01158-2111. Old no. 56262-102 is used for the AT150.

## OBSERVATIONS:

Have you noticed the similarity between the AT-50A and the Cessna RT-359A transponders? Have you noticed the component numbers run almost in the same sequence in both units? This would be a good place to start if someone was making a cross reference of Narco part numbers to Cessna (Sigma Tek) part numbers. Other than the power supply and the receiver they have a mysterious resemblance.

Part Numbers: AT-50A lamp & lens reply light assembly: 011582330 HV Transformer: 118280001

**SERVICE HINTS:**

Courtesy of Tom Kowal, bench tech for Narco Avionics.

The AT-50 and the AT-50A are the same transponder. The only changes in the AT-50A are the modulator and the cavity. Cavities seem to be the least of the problems Tom sees at the factory, perhaps because they can be diagnosed and replaced in the field more readily than some of the more complicated situations which arise. The receiver is one of the major problem areas when showing symptoms of being weak. Many times the problem is a bad mixer diode or the pre-selector cover not being tight enough or clean enough to furnish a good RF ground. An oxidation seems to set in after years of use that contaminates the surfaces and eliminates the bonding needed for good sensitivity.

The power supply problems that surface are usually switching transistors, or an intermittent transformer.

The "Fish-Eye" transistors, as Tom calls them. (Rounded tops 75561-28 & 75596-1 for example) appear to be somewhat troublesome. They are used throughout the unit. Narco stopped using them due to intermittent and inoperative conditions appearing in transistors of this type. The replacement transistors have a flat top.

When bench testing the unit for a no reply light for instance, check the AOC voltage for around 4 vdc. Check the receiver output for having the 2 pulses (P1 & P3). If they are present check step by step through the set. (If no pulses are present go to the power supply.) Check the logic portion. Check the mode A multi's for firing, then go to the clock and ring counter. The ring counter is difficult to trouble-shoot. U111 3,6 and 2,5 have a reversal of signal. All the rest down the line should be checked for half portion or erratic signal.

The multi feeding the modulator transistor Q117, (fish-eye) if temperature sensitive can turn the modulator on hard taking the power supply. Q134 goes first before Q133.

The cavity in the AT-50 is too expensive to repair. Replace the transponder if the cavity is bad.

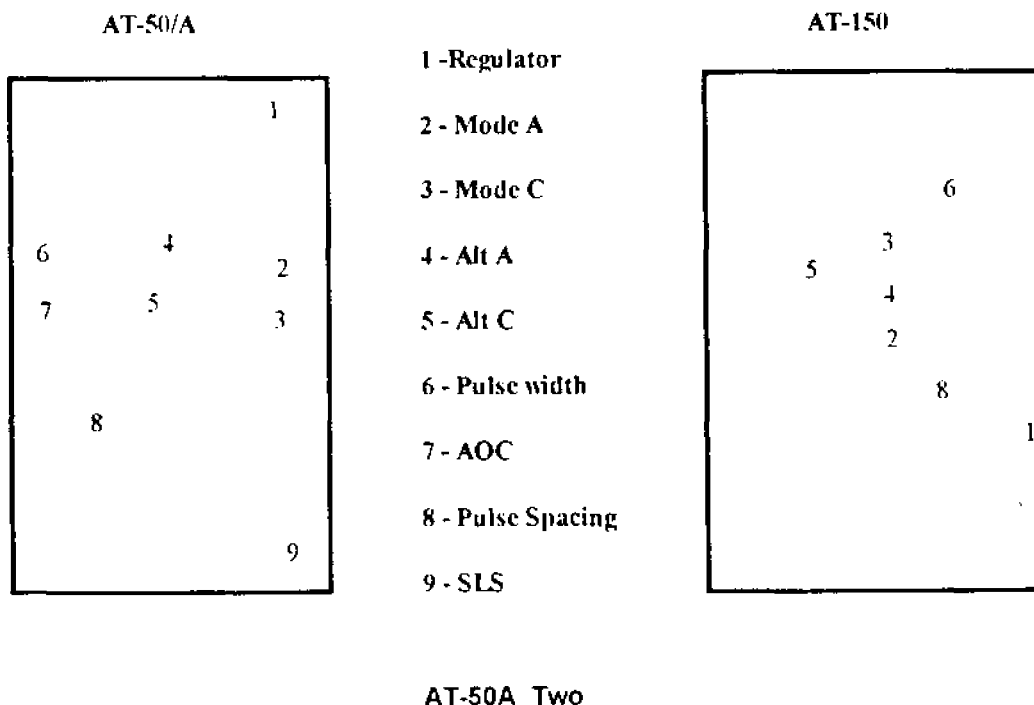

# The Technicians Notebook

By Jerry Gordon

# COM-810/811

Weight: 2.9 lbs (Tray .7 lbs.)

Com 810 is 13.75 volt unit, Com 811 is 27.5 volt unit.

Receiver sensitivity: 1.5 uv for 6 db S+ N/N

AVC 10 uv to 10,000 uv 2 db maximum. Audio output: 10 watts into 4 ohms, 50 mw into 300 ohms.

Transmitter power: 7 watts. Modulation 85%. Duty cycle 20%. Sidetone: 50 mw across 500 ohms.

Revision No: 2, Mar 1996

## SERVICE BULLETINS:

**SB-1** Keep Alive function inspection.

**SB-2** Regarding audio leveling component change: U803 & C807. The Audio Leveling Circuit of the COM units require an IC having specific characteristics, not all 4066's were found to contain them. Therefore, U803 in the Audio Leveling Circuit was changed to a 4016, a more uniform IC. The use of the 4016 requires the change of C807 from a 3.3 uf capacitor to a 1.0 uf capacitor. The new parts, IC 4016 and the 1.0 uf capacitor are now part of every COM and will be found in the COM-810 commencing with sn11600 and in the COM-811 commencing with sn51364.

**SB-3** Regarding COM-810/811 speaker out (P102-N) and mike audio (P102-B). The paralleling of Speaker Out and Mike Audio. The COM 810/811 wiring in any dual COM installation must not result in the paralleling of the COM's speaker outputs nor the mike audios. When integrating a COM-810/811 into a dual COM installation, verify and observe the above limitations.

**SB-4** Regarding FM music picked up through the COM receiver. A few COM 810's of recent manufacture have been reportedly receiving FM Broadcast Stations through the receiver. Refer to the COM 810/811 Maintenance Manual Page 6-9. Remove C710, 100PF chip capacitor and discard. Install new C710, 150 PF chip capacitor. PN24557-0006, 150 PF, 100V rating.

**SB-5** .002 ground station update.

## FIELD SERVICE NOTES: COURTESY OF DON SNYDER, FIELD SERVICE ASSISTANT MANAGER, NARCO

If a Com 810 is found to have weak transmitter power and poor modulation, the B supply is most likely the fault. The B supply should produce 24VDC. If 14 VDC is found coming from the B supply then Q-604 is open.

Occasionally the filter caps open up in the A supply. Hum can be found on the audio, and if bad enough can shut down the supply. Check C602, 6614 and C615 for opens and replace if necessary. Pin # 15 of the regulator should be clean of any RMS. Speaker audio that can't be turned off with the vol control pot is usually caused by an open C-425 (47/10V).

U-402 and U-501 (74224-0001), the LM-378 audio output and modulator IC in the Com 811 and the LM-377 (74224-0002) used in the Com 810 are no longer available. The replacement kit is 74224-0103 which includes replacement instructions. NOTE THE ADF-841 AND THE MARK12D RADIOS ARE ALSO AFFECTED BY THE DISCONTINUANCE OF THESE CHIPS. Use the same replacement kit part number for the ADF-841 and the 28Volt Mark-12D. For the 14Volt Mark-12D and the Cessna Replacement Mark-12D use 74224-0101.

NOTES:

# The Technicians Notebook

By Jerry Gordon

# DME-451

Weight: 5.7 lbs. IND-451 .9 lbs. IND-450 .6 lbs (450-C) .8 lbs.

Power 13.75 or 27.5 VDC Channeling 2 out of 5.

Distance 0 to 199.9 NM, Velocity 0 to 399 KTS.

Power 100 watts, Receiver Sensitivity-80BM (Up to approx. -87 DBM with S-TEC Unit).

Acquisition time < 5 seconds. Audio output 50 MW in to 600 ohms.

Revision No: 1 July 1995

## • SERVICE BULLETINS AND SERVICE INFORMATION TO DATE

SBL	UNIT	TITLE	DATE
SIL			
1	CTS-451	Addition of NAV 1/2 Switch	Jan. /79
1	IND-450	Reduction of VHF Interference on DME Operation	Oct 5/79
1R1	IND-451	RNAV Mode NAV/NAV2 Wiring Change	Oct 20/78
2R1	IND-451	Interface with AP-106 Auto pilot	Aug 1/80
3R1	IND-451	GMT Clock Transient Tolerance Improvement	Sep 23/80
4	IND-451	Addition of Display Inhibit	Sep 8/80
5	IND-451	Reduce GTM Clock Susceptibility to Power Transients	Jan 30/81
1	TCR-451	Digital Distance Interface	Sep 1/77
2R1	TCR-451	Ground speed Initialization Circuit	Jan 15/79
3	TCR-451	Prevention of IF Amplifier Oscillation	Apr 28/78
4	TCR-451	Loss of Lock When Channeling Non-DME Coupled NAV	Nov 15/78
5	TCR-451	VHF Comm to DME Interference	Nov 15/79
6	TCR-451	Delayed NAV System Mode Control Response Time	Jan 14/80
1-78	IND-451	IND-451 Wiring Change	Jan 18/78
2-78R1	IND-451	GMT Clock Failure	Dec 15/79
3-78	IND-451	Improved F/S Clock Switch	Dec 22/78
1-78	IND-451	Intermittent Channel 27 Operation	Aug 15/78
1-79	IND-451	DME to VHF Comm Interference	Nov 1/79
1-80	TCR-451	Improper Installation of Capacitor C1	Jan 14/80

FOLLOWING COURTESY OF CUSTOMER SERVICE, S-TEC CORP.

### ORDER OF TROUBLE SHOOTING DME.

- Power Supply.
- VCO & Channeling of I/O Board.
- Multiplier
- Receiver to -50 DBM.
- Transmitter & modulator.
- Receiver to -80 DBM (-86 DBM for S-TEC TCR-451).
- Distance Board.

### PROBLEMS & FIXES:

- Low power output, low receiver sensitivity.*
  - Should have low power out of multiplier (10 mw across band @ receiver coax to mixer).
  - Should have normal power out of VCO to multiplier.
  - Check all 100 pf bypass caps around front end of multiplier (C542,543,544,548,549,556)
  - Bridge across each capacitor and replace bridged capacitor if power comes up.
- Look for 12V peak to peak video @ -50 to -60 DB.*
  - AGC on I/O BD. Problems in this area can be Q110 & U113.
- If receiver is down to -66 DB sensitivity & 1 of the pots R651,652,653,654 on receiver has no effect, the problem can be:*
  - Broken varactor or cold solder joint at mating cap, or broken 1/8 watt resistor in preselector.
- If down to -70 DBM sensitivity on receiver:*

1. Set IFR 1200S on 63 megs and set IFR 1400 on continuous output.
2. Use scope probe at antenna input of IFR 1200S and monitor output from mixer at Q605 drain for approximately 4 to 8 DB gain, then across Q601 for about 10 to 12 DB gain.

**E. Replacing Q501-Q504 in power amplifier.**

1. Q501, Q502 solder in position down as far as transistor will go.
2. Q505 solder in position to front as far as transistor will go.
3. Q504 solder in position according to notice shipped with new Q504. (See drawing)
4. Remember: Q501 down. Q502 down. Q503 to front.

**PARTS & CHANGES**

- A. Q605 Receiver Board: New Part SPF 703.
- B. U604 Freq STD: New PN 351-7786-010.
- C. Q504 Power amplifier. \* New part may not produce output levels necessary for proper operation.

\*NOTE: The TCR451 manufactured by S-Tec has changed -80 DBM receiver sensitivity to -87 DBM to compensate for lower output power of Q504. Any unit replacing Q504 should have this modification installed.

Parts list for RF probe, (See drawing).

1. Coax 4' PN 425-0222-040 (Collins)
2. R1 10K 1/4W PN 745-7950-370
3. CR 1 PN 4816-0000-001 (IFR)
4. L1 1.5 uh PN 240-2025-000 (Collins)
5. C1 47 pf PN 23470K20R (S-Tec)
6. BNC crimp PN 225395-1 (Amp)
7. Probe Radio Shack Test Lead.

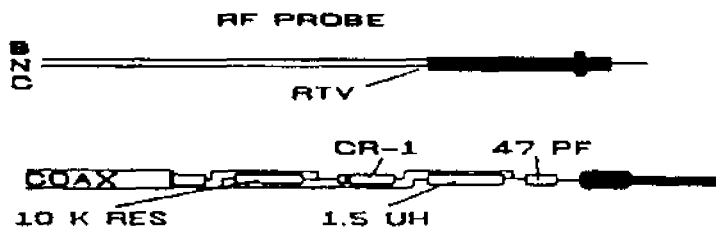

**Operation:**

1. The 4 ft of coax is the filter capacitor to provide DC to the 1 meg input to a scope.
2. The probe is necessary for working on the transmitter.
3. This probe will work from the synthesizer output through the multiplier, through the power amplifier, and to the collector of the output transistor.
4. Note the probe will crater if used in the output of the VHF-251 & VHF-253, but will work to the input of the base of the output transistor in the VHF-251 & VHF-253.
5. Do not use it at the output of the TDR-950.
6. For unmodulated RF, the probe will provide a dc output proportional to the amplitude of the RF. For modulated RF the output will be a representation of the modulation changes.

**NOTICE**

New regulations for DME equipment operating at over sixteen (16) pulse pairs per second, call for restricted power output to "less than" 100 watts.

In light of this restriction and due to the limited to no availability of the MSC80377/SRF2848 device, the MRF 1150 is now being used in current production and is substituted as a replacement for Q504 under the same part number 352-5057-010.

This device, when mounted as shown, is capable of producing from 90 to 115 watts in the TCR-451 transmitter.

**NOTES:**

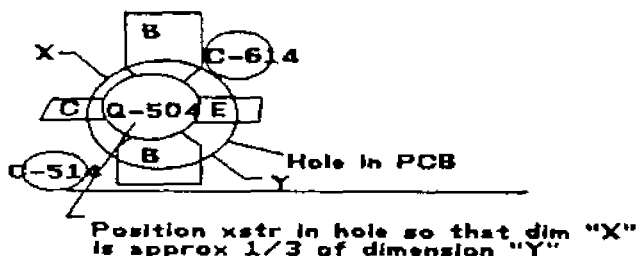

# The Technicians Notebook

By Jerry Gordon

# DME-890

Revision No: 1 6/1996

Weight: 3.3 Lbs. Mounting Tray: .63 Lbs. Antenna/Cable: .5 Lbs.  
Transmitter Power: 25 Watts Nominal, 22 Watts Minimum.  
Receiver Sensitivity: -82dBm Minimum. Range: 160 NM. Memory: 8-10 Seconds.  
Audio Output: 10 Mw, typical.  
Range Accuracy: .1NM Nominal/.4 NM Maximum. Ground Speed Accuracy: 5 Knots or 5%.  
Time To Station 0-99 Minutes.

## SERVICE BULLETINS:

**DME-890-1** A new power supply was developed and implemented commencing with power supply level E as shown below. This is not a mandatory mod but is recommended if replacement of the DME-890 power supply is necessary. A power supply kit is available under Narco part number: 03314-0505. Some modification on the main board is necessary.

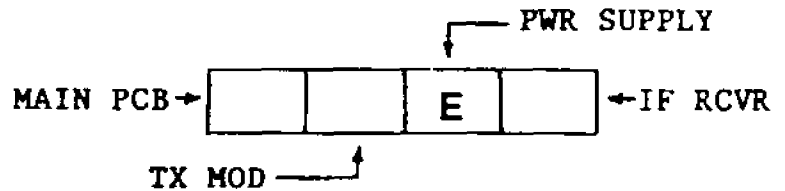

THE FOLLOWING IS COURTESY OF TOM KOWAL AND JACK VOGEL, CUSTOMER SERVICE, NARCO AVIONICS:

There is only one service bulletin to date on the DME-890. It has been relatively free of digital problems. Some of the repeating symptoms have been weak or intermittent receiver and some display problems. If you have a weak or intermittent receiver, temporarily ground CR-104/CR-105 junction, or L-109. If gain improves replace the mixer diodes. There are no eyelets on this portion of the circuit board so be sure to solder the leads on the top and bottom of the board. Heat sink the diodes and saturate them with heat to remove the impurities on the wire. Also be sure to bend over the leads to pick up more ground surface.

**Transmitter problems:** Resolder areas of transmitter board around Q-101 and Q-103 and the variable caps. If you have distortion on the transmitter waveform, check for noise on the 14 volt line and replace the filter cap if necessary. (C-807)

### POWER SUPPLY OUTPUT VOLTAGES:

**Display problems:** Some digits are lit brighter than others. Replace C-323. If you see some legends flashing dimly, trying to light, check for fuzz on the + 100 volt and -100 volt lines. If you have noise there replace C-805 and C-810.

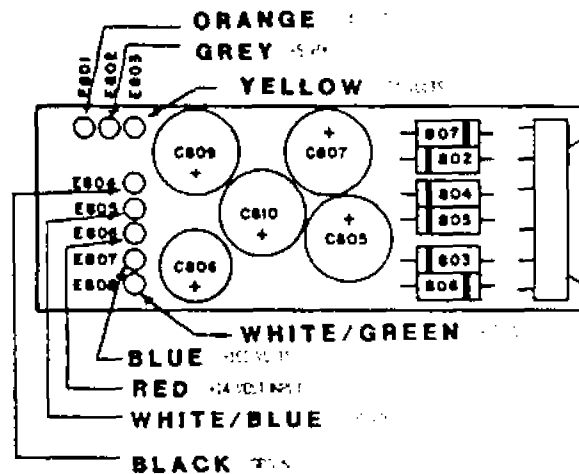
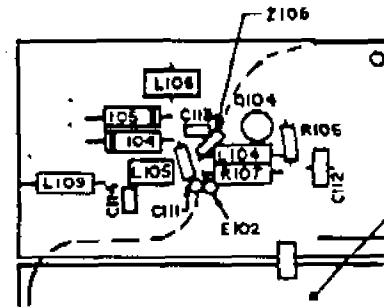

DME-890 One

# The Technicians Notebook

By Jerry Gordon

# IN-385/386/AC

Revision No: 10 7/1996

WEIGHT: 2.1 LBS, IN385AC/386AC 2.3 LBS  
 INPUT: .5VRMS, VOR & LOC  
 ACCURACY: 2.7 DEGREES

There are no service bulletins since 1978 for these units. Because the manual has all the boards on separate pages making it difficult to locate alignment points, I will cover the alignment and some part numbers in this issue.

Test set & unit to 75 deg. Remove 30hz and adjust A4R10 for center. Replace 30hz and adj A4R6 for center needle. Reverse To/From and adj A4R10 for half error. Test set & unit to 345 deg. With DVM on undamped vert deviation outputs adj A3R18 for same reading while setting the test set TO and FROM. Set test set to 355 deg (TO) and OBS to 345 deg. Adj A4R18 for 150 mv on the DVM. Reduce the VOR input until the DVM reads 77mv. Adjust A6R17 until the NAV flag drops into view.

VOR self test. Test set and resolver to 0 deg. Close VOR test switch. Adj A3R15 for center needle. Open the VOR test switch. Adj A4R24 for center.

Auto Radial.

Pull OBS knob out. Adj A2R19 for heading. Adj A2R21 until card oscillation just stops.

Localizer Calibration:

Energize the ILS. Apply a standard LOC center signal, adj A4R13 for center.

Apply a standard right signal. (90 mv), adj A4R11 for QUAD 90 mv. (3 dots right) Reduce the signal to half scale (.47mv) Adj A6R35 (A6R5) on some models for a fully visible NAV flag. Restore the signal to normal. Remove the 90 hz mod. The NAV flag should be fully visible. If not, adjust A6R35 (R5 on some models) Restore 90 hz and remove 150hz mod. The NAV flag should be fully visible. If not adjust A6R35 (R5 on some models) again until it is. Keep doing this until you do not have to adjust R35 (R5) any more. Restore the LOC signal. Recheck for normal operation of the LOC

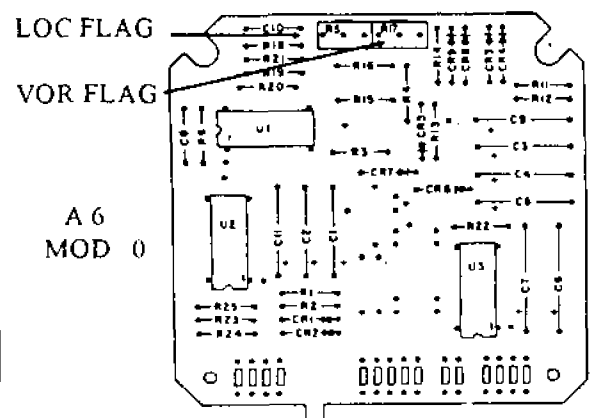
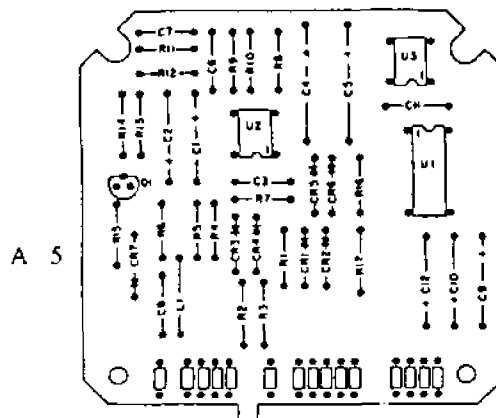
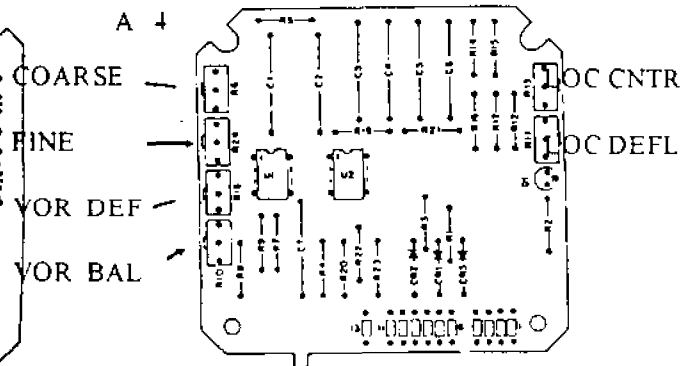
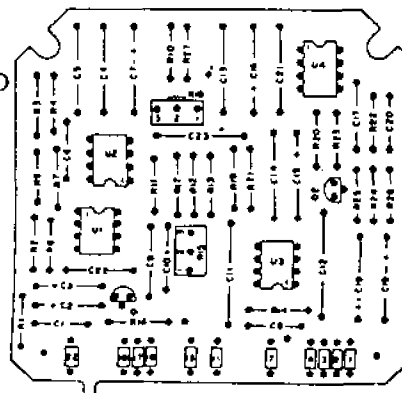
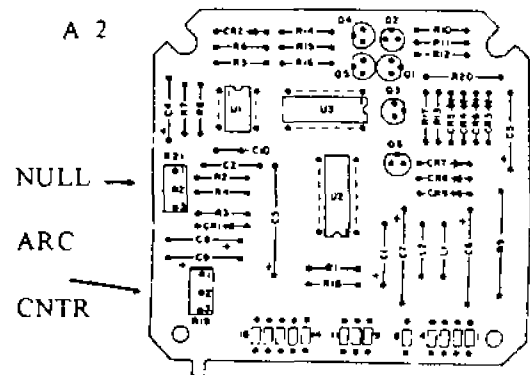
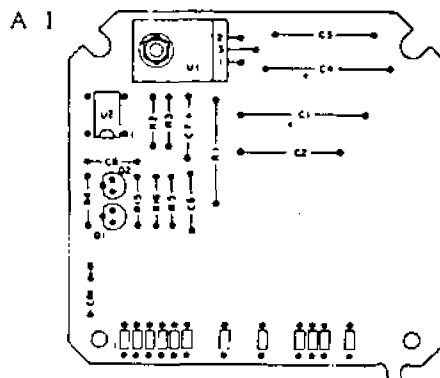

IN-386 One



A4 MOD 1  
BOARD

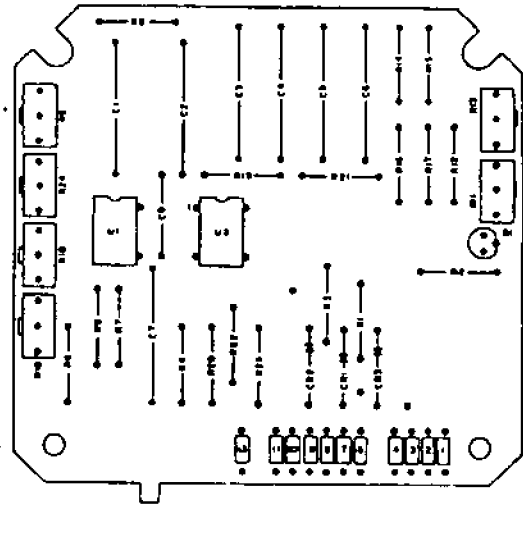

A1 BOARD, IN-386 MODEL

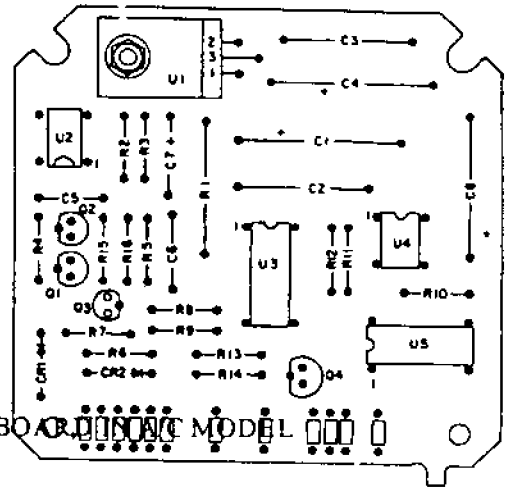

**PART NUMBERS:**

- |  |           |
|--|-----------|
| Connector kit: (Solder contacts and right angle shell) | 363640000 |
| Connector kit: (Crimp contacts and right angle shell)  | 363640001 |
| Connector kit: (Solder contacts and straight shell)    | 363640002 |
| Connector kit: (Crimp contacts and straight shell)     | 363640003 |

- |                        |           |
|------------------------|-----------|
| IN-385A METER ASSY A8  | 468451000 |
| IN-385AC METER ASSY A8 | 468451200 |
| IN-386A METER ASSY A8  | 468452000 |
| IN-386AC METER ASSY A8 | 468452200 |

**NOTES:**

## The Technicians Notebook

By Jerry Gordon

# KI-201C/214

Revision No: 1 3/1995

**Weight:** KI-201C 2.8 lb., KI-214 3.0 lb.. (SN 5399 & below, 2.9 lb.)

**Input Impedance:** 30 K ohms. **Input Levels:** VOR .5 VRMS, LOC .35 VRMS

**LOC Sens:** 4 db tone ratio for full deflection, **VOR Sens:** 10 degrees for full deflection. **Accuracy:** 2 degrees.

**External load:** Hi Z Auto Pilot Deviation.

**Glide Slope:** Input impedance 50 K ohms. 40 channels. Sens: 40 uv hard for 1/2 flag & 60% standard deflection.

**External load:** Arinc & Auto pilot (Hi Z) 1 flag & 1 deflection.

**Part Numbers:** OBS drive belt, 029-00004-0000, Meter gasket, 187-01051-0000, VOR Adj Pot, 133-00022-0000

**VOR Centering adjustment:** Through OBS shaft with long straight slot screwdriver.

**HINT:** VOR inop but LOC works, check C-327

### SERVICE BULLETINS:

**KI-201C-1** Applicable to SN 6602 & below, KI-211C SN 4981 & below. To increase to/from circuit drive capability for new type of to/from/ flag meter. Old meter was 100 ua at 1K ohms. New meter is 500 ua at 100 ohms. Change Q-304 & Q-305 to 2N5305 (007-00129-0000), change value of R-312 & R-313 to 100 ohm 1/4 watt resistors, adding R-369, a 1 meg pot (133-00016-0004), Delete R-314. Remove CR-302 and replace with a jumper. New meter movements are: 023-00057-0004 for a KI-201C, 023-0056-00005 for a KI-211C. Time required 2 hours.

**KI-201C-2, KI-211C-4, KI-214-1** Applicable to KI-201C SN 10982 & below, KI-211C all Serial Numbers, KI-214 SN2763 & below. To eliminate the possibility of the flag pulling with no signal present. Also improves higher temperature operation. Add R-370 (130-00154-0023), CR-309 1N277 (007-06023-0000), re configure R-332. Kit 050-01381-0000. Time required 2 hours.

**KI-201C-3, KI-214-6** Applicable to KI-201C SN 15489 - 18347, KI-214 SN 5588 - 7044. In the listed units C-321 was changed from a .001 uf to a .01 uf cap. The .01 cap can cause VOR tracking errors of 3 to 4 degrees. Replace C-321 with a .001 uf @ 100V 10% mylar cap (105-00024-0000).

**KI-214-2** Applicable to SN 2711 & below. To improve VHF transmitter RFI rejection in the Glide Slope receiver. Add 100 pf disc ceramic caps in parallel with base emitter junctions of Q-902- Q-903, and Q-904. Keep the leads very short. Kit 050-01400-0000 consists of 3 ea. caps 113-05101-0001.

**KI-214-3** Applicable to SN 3225 & below. To prevent oscillation in I901 when Glide Slope channel selector is rapidly channeled. Add 100 pf disc ceramic capacitor (113-05101-0001) from pin 14 of I-901 to ground.

**KI-214-4** Applicable to SN 5540 & below. For Glide Slope needle oscillation. Change R-481 to 1K 1/4 watt resistor (130-00102-0023). Change R-943 to same. Delete C-906 (100 uf tantalum cap.) Time required: 1 hour.

**SI-214-5** Applicable to all serial numbers. When used with a KFC-200 system, the deviation must be readjusted. Localizer deviation: 150 hz, 4db & select R-331 for 3 dots deflection. Glide Slope deviation: 2db up, adjust R-927 for 78 ua measured between pins W & Y. Verify equal deflection with 2 db down. Time required: 1/2 hour.

### NOTES:

## The Technician's Notebook

By Jerry Gordon

# KI-208/209/208A/209A

Rev. 3, May, 2000

**Weight:** KI-208 1.0 Lb. KI-209 1.2 Lb.

**Input Impedance:** 50K ohms, Nominal

**Nominal Composite input:** LOC: .33VRMS, VOR: .5VRMS, ARINC Phased

**Localizer Sense:** 4db tone ratio for 3 dot deflection, Omni Sense: 10 degrees for full scale deflection.

**Omni Accuracy:** 2 degrees max error, 1 degree typical. Ext. Load: ARINC auto pilot div. (Two 1 K loads)

**G/S Deviation Meter:** Input Impedance: 1 K ohm, Deflection Sens: 150 ua for full scale deflection.

**G/S Flag Meter:** Input Impedance: 1 K ohm, Deflection Sens: 125 ua for flag to move, 260 ua max for F/S.

### SERVICE BULLETINS:

**KI-208/209-1** (Applicable to KI-208 sn 1300 and below, KI-209 sn 1033 and below) To reduce spurious deflection of the meter movements caused by extreme RF from the comm transmitter. If the comm is desensitizing the nav receiver, this mod will not help. This is apparent if the problem varies with nav frequency. If this is your problem, call product support for help. This mod adds three caps to converter board # 1 and three caps to converter board # 2. Parts required: 6 ea. 113-03121-0000 120pf @500 v, 5% disc ceramic caps. Time required: 1.5 hours

**KI-208/209-2** (Applicable to KI-208 sn 1462 and below, KI-209 sn. 1212 and below) If FM discriminator IC I-201 is replaced with a new type now available, it may cause a problem. The new type has a narrower operating range. This mod enables replacement of FM discriminator I-201 to be the new or old type of IC. This mod changes one resistor (R-206) on converter board # 2 and requires the alignment of the phase locked loop as per Par 6.2.4.4 on page 6-7 of the maintenance manual. Parts required: 1 each 130-00753-0023 75K ohm 1/4 watt 5% resistor. Time required .5 hours.

**KI-208/209-3** (Applicable to KI-208 above sn 16688 and below sn 58156, KI-209 above sn 12122 and below sn 59738.) To improve erratic needle and flagging during VOR operation caused by noise on the VOR composite signal. This mod consists of adding a 9960 Hz filter by adding components. See Bulletin for details. Parts required: 1 each 050-03165-0000 Kit. Time required 2.5 hours.

**KI-208/209-4** (Applicable to KI-208 sn 67699 and below, KI-209 sn 73879 and below.) Consists of applying humiseal to the converter board. Factory mod only. Superseded by mod 5. Refer to mod 5.

**KI-208/209-5** (Applicable to KI-208 sn 69200 and below, KI-209 sn 75000 and below.) To improve operation under extremely humid conditions. Consists of replacing #1 converter board (200-05848-0000) with new converter board (200-05848-0001), and #2 converter board (200-05849-0000) with new converter board (200-05849-0002). OLDER CONVERTER BOARDS CANNOT BE USED IN A UNIT THAT HAS MOD 5 INSTALLED. This is a factory mod only.

**KI-208A/209A-1** Mod 1 was NOT incorporated in the original manufacturing of these indicators. It changed the unit's back plate and covers. It was superseded by mod 2. Refer to mod 2.

**KI-208A/209A-2** (Applicable to KI-208A sn 1050 and below, KI-209A sn 2330 and below). Consists of replacing the back plate and the top and bottom covers. This is a factory mod only. It is covered under warranty if the unit is still under the new product warranty. Warranty covers two hours labor for removal and installation.

**KI-208A/209A-3** (Applicable to KI-208A sn 1069 and below, KI-209A sn3559 and below.) Consists of application of humiseal to the converter board for improved operation in extremely humid conditions. This is a factory mod only. It is superseded by mod 4. Refer to mod 4.

**KI-208A/209A-4** (Applicable to KI-208A sn 1250 and below, KI-209A sn 5000 and below.) To improve operation under extremely humid conditions. Consists of replacing #1 converter board (200-05848-0000) with new converter board (200-05848-0001), and #2 converter board (200-05849-0000) with new converter board (200-05849-0002). OLDER CONVERTER BOARDS CANNOT BE USED IN A UNIT THAT HAS MOD 5 INSTALLED. This is a factory mod only.

**SERVICE MEMOS:**

**S.M. 211** External VOR and LOC centering adjustments on the KI-209/209 Indicators. The VOR centering adjustment is behind the top left mounting screw and the LOC centering adjustment is behind the top right mounting screw. They can be adjusted with a jeweler's screwdriver or a special King tuning tool. (088-00706-0000). CAUTION, mounting screws longer than 3/4 inch will cause damage to the VOR/LOC centering adjustments.

**S.M. 325** Tracking capacitors have been changed to an improved part. They must be changed in matched sets of four. The part number for a set of four is 108-06005-010. Each capacitor in the set should have the same date code. The capacitors affected are C-206, C-207, C-208, C-209.

**SERVICE AIDS:**

**S.A. KI-208/209-101** Product improvements incorporated on KI-208 sn. 4155 and above and KI-209 sn. 3764 and above. R-206 was changed from a 75 K resistor to a 68.1K precision resistor. (136-06812-0072) and R-207 was changed to a 200K variable resistor (133-00096-0037) to improve the stability of the FM discriminator. In KI-208 sn. 16688 and above and KI-209 sn. 12122 and above several components were changed to prevent the flag from being pulled when just receiving a single tone variable only condition. 0-202 & CR-201 were deleted. C-202 changed from 560pf capacitor to a .0027uf capacitor (111-00001-0014) and relocated to the former position of CR-201. A 1.5K ohm resistor, R-249 (131-00152-0023) was added and located in the former position of C-202. C-218 (111-00001-0005) was added from the junction of R-249 and C-202 to ground. C-203 was changed to a 1 K pf capacitor. (111-00001-0035) R-204 was changed to a 12K resistor. (131-00123-0023).

**SA KI-208/209-102** Matching of I-201 to C-204. When replacing I-201, C-204 must be a matched value. When you order an I-201, 120-06038-0002, you will receive a 195-00099-0000, which will consist of an IC with a matched capacitor. The IC may have a green or orange dot.

**INSTALLATION BULLETINS:**

**IB # 108 Revised** identifies an intermittent failure trend of the Burndy connectors between the connector of the mating harness and the connector of the unit. The locking tab on the Burndy connector fails to hold the connector in place inside the mounting block and when the two connectors are pushed together the affected pin slips back in the block making an intermittent connection. Check all pins by pushing or pulling on each one slightly. If any are loose, extract them and bend the locking tab to insure proper locking in the block. Complete connector assemblies can be obtained: KI-208 230-00208-0091 KI-209 230-00209-009

**IB #451** KI-208/208A/209/209A are now TSO'd to 55,000 feet. No changes are required to achieve successful performance at 55,000 feet. The only change to the unit will be on the serial tag. The serial tag will state 55,000 feet instead of 15,000 feet. The changes will be included in the next revisions of the affected installations manuals,



**REGULATOR ADJUSTMENT:**

Digital voltmeter on TP-308 and adjust R-321 for 9.2 vdc.

**PHASE LOCKED LOOP ADJUSTMENTS:** No composite applied, counter on pin 3 or 4 of 1-201, adjust R-207 for 9960 Hz.

**VOR ALIGNMENT:**

- A. With no signal applied, needle should be centered within 1/2 needle width.
- B. With .5vrms composite applied, set generator and obs to 90 degrees (from).
- C. Adjust R-233 on top board (Through left top mounting screw hole) for center needle.

## **KI-208/209/208A/209A Technician's Notebook**

- D. VOR generator to 270 degrees, adjust R-233 for half the distance to center the needle. If more than 2 degrees off, you may have a bad output stage or an incorrectly set azimuth card. (See manual) ,
- E. Set VOR generator to 280 degrees and adjust R-203 on top board for 5 dots right deflection.
- F. Rotate VOR generator to 260 degrees and check for 5 dots left deflection. If necessary, readjust R-203 to balance left and right deflections.
- G. Repeat C and D and align for minimum centering error at 90 degrees TO and FROM. If more than 1 degree error, trouble shoot the VOR converter.
- H. VOR generator to 0 degrees and unit OBS to 0 degrees (from). Adjust R-241 for center needle.
- I. VOR generator to 180 degrees (to) and readjust R-241 for 1/2 error.
- J. Repeat H and I to align for minimum error. If error more than 1.5 degrees, trouble shoot the VOR converter.
- K. OBS to 90 degrees, VOR generator to 80 degrees. Lower the composite so the needle deflects only 2 1/2 dots.
- L. Adjust R-323 so flag is 1/3 in view.
- M. Return the VOR generator output to .5vrms.

### **LOCALIZER ALIGNMENT:**

- A. LOC generator for center needle .35 vrms. Adjust R-227 (Through right top mounting screw hole) for center needle.
- B. LOC generator for 4db (.093ddm) on each side and adjust R-313 on bottom board for 3 dots deflection.
- C. LOC generator for center, switch between cal 90 and cal 150. Leave the generator at the setting that has the least amount of flag in view.
- D. Adjust R-310 so that the flag is 1/3 in view. This ends the calibration.

### **NOTES:**

# The Technician's Notebook

By Jerry Gordon

## KLX-135/135A

Revision No: 0 6/1997

**Weight** 5.02 lbs. w/mounting rack and connectors.

**Com receiver** sens: 2 uv (hard) for 6db (s+n)/n with 1 khz @30% modulation

**AGC:** <3db from 5 uv to 20,000 uv

**Audio output:** 100 mw @ 500 ohms. Audio amp output: 8 watts @4 ohms

**Com transmitter:** Power output 5 w min within .001% accuracy. Sidetone up to 100 mw @ 500 ohms Duty cycle 10%

**Gps Outputs:** CDI en route 30mv per n/m, up to 5 ea 1k loads, 150 mv full scale.

**Nav Flag:** Pulled 260 to 900 mv, in view <50 mv, up to 5 ea 1k loads. To-from flag: (TO) +40 to+300 mv, from pin S to pin R. (FROM) -40 to -300 mv from pin S to pin R. Up to 5 ea 200 ohm loads.

### SERVICE BULLETINS:

**KLX-135-M1 *Factory mod only*** to upgrade a KLX-135 to the equivalent of a KLX-135A. This includes a new display, plus new software including: Moving map page, nearest page, special use airspace, airport runways, altitude/air speed/winds aloft, nearest FSS, ARTCC names & frequencies, local timezone, and resegmentation of database to three regions. Kit part number (050-03350-0000)

### SERVICE AIDS:

**KLX-135-101** Replacement of the gray bezel (088-01383-0004) with black bezel (088-01383-0005).

**COMM MISC ADJUSTMENTS:** For complete alignment see maintenance manual.

**COMM VCO** adjustment: Channel to 136.975, monitor collector of Q4024 with frequency counter, adjust C4086 for 148.375 mhz. Done within 60 seconds of turn on. Adjust T4007 for 7.3 vdc at TP4009.

**Transmitter adjustment:** Adjust R4207 for minimum of 5 watts across the band. Adjust C5018 ( on tx board) for minimum power variation across the band. Variation should be less than 2 watts.

**Modulator adjustment:** Frequency at 118.00, apply .4vrms, 1khz to mike input. Adjust R4146 for 85% modulation. Adjust R4172 for 70%. Check at 128.5 and 136.975. Re-adjust only if the modulation is lower than 70%.

**Sidetone adjustment:** With standard mike input signal, adjust R4105 for 4mw (1.4 vrms) into 500 ohms.

**Receiver adjustments:** Set frequency to 130.50mhz. With input at 100 uv (hard) frequency modulated with 20khz, deviation 50 khz, adjust T4002 for minimum ripple at TP4001 on scope.

**Noise Squelch adjustments:** With PullTest knob is pushed in. Turn on the compressor. Apply 2.0 uv (hard) of 128.5 mhz modulated 30% with 1khz tone. With R4048 in max clockwise position, adjust R4065 until the receiver just breaks squelch.

**Carrier squelch adjustment:** With 12.5 uv (hard) at 130.5 mhz am modulated with 8 khz at 85%, adjust R4048 for just breaking squelch.

**Climax filter adjustment:** With 100 uv (hard) at 130.5 mhz am modulated with 4.5 khz at 85%, disable the squelch and monitor the audio output. Adjust L4013 for minimum output.

### **Audio amplifier gain adjustments:**

**Speaker gain:** With 100 uv (hard) at 130.5 mhz am modulated with 1 khz at 30%, set volume control for 100 mw (7.07 vrms) at 500 ohm output. Connect the 500 ohm output to the 4 ohm input (J4001 pin 5). Adjust R4237 for 8 watts (5.65 vrms) at 4 ohm output. (J4001 pin 8). Connect audio sum out (J4001 pin P) to 4 ohm amp input (J4001 pin S). Set R4237 to 0 ohms. Then adjust R4238 for 8 watts (5.65 vrms) at 4 ohm output (J4001 pin P).

**Intercom mike gain adjustment:** With volume control down, apply 19 mvrms 1khz to intercom mike in (J4001 pin D). Adjust R4221 for 100 mw (7.07 vrms) at 500 ohm output. Then apply .4vrms to intercom mike in and adjust R4221 again for 100 mw (7.07 vrms) at 500 ohm output.

### **THE FOLLOWING IS COURTESY OF ALLIED SIGNAL FIELD SERVICE:**

- **Some conditions noted by technical service:**

A unit that has been subjected to an input voltage of 28 vdc will create the following conditions: The fuse (F4001) and the audio amp (U3001) will be destroyed. The KLX-135 is a 14 volt unit.

Another problem is encountered when the wrong database diskette is loaded. If a KLX-135A diskette is loaded in a KLX-135, a lock-up will occur that will require sending the unit back to the factory.

If a KLX-135 diskette is loaded in a KLX-135A, it will not recognize it. It will appear as if there is no database installed. This can be corrected by using the correct diskette.

If a System error of 003 or 006 appears, the probable cause may be poorly soldered pins on the IC sockets located on the digital board. Remove the IC's and check for pins lacking solder contact to the board. Another result of this problem may be 2 lines displayed on the front panel and the unit will be locked up. The pins on the microprocessor may also be subject to the same problem.

If the GPS fails the final test before return to service, the unit will have to be returned to the factory.

If the lithium battery fails earlier than 3 years from new, don't just replace the battery. There are some capacitors that can become leaky, thereby reducing the life of the battery. Check the current drain with a microammeter for a normal current drain of 120 - 130 microamps. If it is considerably more check C-27 on the digital board. There also is a capacitor on the GPS board that can cause this problem. To verify a leaky cap on the GPS board, remove the cable from the board while checking the battery drain. If the problem is traced to the GPS board, return the unit to the factory.

### **NOTES:**

# The Technicians Notebook

By Jerry Gordon

# KMA-20

Revision No: 1 5/1996

Weight: 2.3 Lbs.

Marker Light Sens: 2,000 uv hard, Low Sens. 500 uv hard, High Sens.

Marker AGC: < 6db from lamp threshold to 200,000 uv.

Isolation Amplifier: Input impedance: 500 ohms. Input isolation between channels, 40db.

Audio Output: 6 1/4 Watts - 14 Volts, 8 Watts - 28 Volts.

## SERVICE BULLETINS:

**KMA 20-1** Alternator whine. (Applicable to s.n. 1719 & below) This mod replaces, adds, and deletes components. If you find one this old, look up original documentation for details.

**KMA 20-2** Marker lamp and audio output. (Applicable to s.n. 6899 & below) To assure marker lamp brightness when paralleling external marker lights and to eliminate audio oscillation when speakers used are other than 4 ohm impedance. Parts required: Kit 050-01387-0000. Time required 2 hours.

**KMA 20-3** Modification to be compatible with KT-96. (Applicable to all s.n.) This mod adds another mike position to the mike selector and a new face mask for proper labeling. Parts required: Kit 050-01469-0000. Time required: 2 hours.

**KMA 20-4** (Applicable to s.n 27274 & below) To eliminate voltage transients from the mic key line when using other than King comms. The mic key line of the KMA-20 may be subjected to large voltage transients when the microphone is unkeyed. These voltage transients are generated from the T/R relay of the comm transmitter selected by the KMA-20. All current King comm transceivers incorporate a diode on the T/R relay, however, other vendors comm units may not. The voltage transients generated may easily exceed the break down voltage of the diodes on the mic key line of the KMA-20. An earlier version of this mod placed a 20 volt zener across C-320. If a 28 volt keying relay is used with the 20 volt zener, it may cause the transmitter to stay keyed until power is removed from the mike key line by switching to another comm or by turning the avionics master off and back on. This mod adds a zener diode (CR-309) to the mic key line when using other than king radio comms or to eliminate keying problems caused by improper cr-309. Parts required: 1 ea. 007-05011-0025 1.5 watt, 36 volt zener. Time required 1/2 hour.

## SERVICE AIDS:

**KMA 20-101** Change of transistors Q-115, Q-116, and Q-117 to new type. The new transistor (007-00246-0001) is a SPS6830 NPN Darlington with a higher power rating.

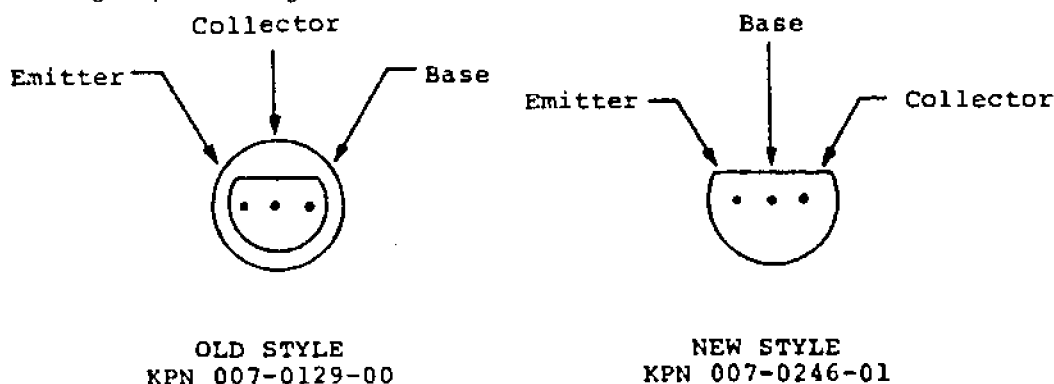

**KMA 20-102** Replacement of local oscillator. If the oscillator Q-118 or the surrounding components are changed, the oscillator may fail to start. To prevent problems, the oscillator has been redesigned. Any time one of the components listed below are changed, they should all be changed.



COMPONENTS	OLD PART NUMBER	NEW PART NUMBER
Q-118	007-00028-0000 SE3001	007-00195-0000 MPSH10
Y-101	005-00045-0000 Crystal 85.7Mhz	044-00123-0000 Crystal 85.7 Mhz
C-144	113-03150-0000 15pf DC Cap	113-03270-0000 27pf DC Cap
C-146	113-03270-0000 27pf DC Cap	113-03390-0000 39pf DC Cap
C-147	113-03100-0000 10pf DC Cap	113-03390-0000 39pf DC Cap
L-104	019-02055-0010 .33uh 10% Choke	019-02084-0001 .15uh 10% Choke
R-166	130-00471-0025 470ohm 1/4W 10% Res	131-00151-0023 150ohm 1/4 W 10% Res

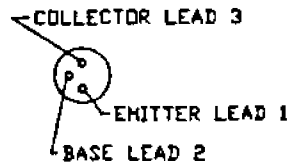

007-00028-0000



1. BASE
2. EMITTER
3. COLLECTOR

007-00195-0000

IF SOMEONE COMPLAINS OF NOT SEEING THE BLUE OUTER MARKER LIGHT, ORDER AN 088-00145-0004 LENS AND REPLACE THE PRESENT ONE WITH IT.

**SERVICE AID: FEB/92** The marker voltage regulator transistor Q-106 has been replaced by a 3 terminal regulator I-101. To install the new regulator, CR-102 is changed, C-150 & R-124 are removed, and wire jumpers are changed. Parts required: 120-03026-0018 (MC7808ACT Regulator) and 007-05039-0000 (33.3 Volt Zener Diode). Remove and discard CR-102, R-124, C-150, and Q-106. Remove the buss wire jumper between the standoffs P-117 & P-118. Disconnect the buss wire jumper between the standoffs P-111 & P-114 at P-114 and re-route it to P-118. Install the new zener diode, CR-102, with the anode to the ground standoff and the cathode to P-111. The new regulator, I-101, has a tab and 3 pins. The center pin and the tab are both ground connections. The center pin for this application is to be cut off close to the body to prevent shorting. Install I-101 in the same location as Q-106 without the insulator. Connect the input and output leads to P-118 & P110 as shown and retain the connection from the ground tab to P-117.

**NOTES:**

# The Technicians Notebook

By Jerry Gordon

# KMA-24

Weight: 1.7 Lb..

Marker Sensitivity: 1,000 uv hard - Low, 200 uv hard - High

Isolation Amplifiers: Input Impedance: 500 ohms. Isolation between inputs: 40 db.

Speaker Output: 13.75 Volt supply: 7 watts into 4 ohms, 4 watts into 8 ohms.

27.5 Volt supply: 12 watts into 4 ohms, 6.5 watts into 8 ohms.

Phone Output: 50 milliwatts into 500 ohms.

Revision No: 1 6/1996

## SERVICE BULLETINS:

**KMA 24-1** (Applicable to s.n 1870 & below) To prevent fuse from being blown. This mod consists of changing F-201, C-211, and C-215. If you find one below this serial number, any King Service Center may perform this mod and be reimbursed by King for 1 hour labor plus parts.

**KMA 24-2** (Applicable to s.n. 2296 & below, except s.n 2297 thru 3445.) To improve operation of and prevent loss of speaker audio in cold environment. This mod consists of changing components and replacing I-202 with a mod board assembly. Parts required: Kit 050-01925-0000. Time required 1.5 hours.

**KMA 24-3** Not assigned.

**KMA 24-4** (Applicable to s.n 4599 & below) Narrow band pass for international requirements. This mod consists of changing the values of resistors R-121 thru R-132. Parts required: Kit 050-01927-0000. Time required 2 hours.

**KMA 24-5** (Applicable to s.n. 13315 & below) To improve marker receiver local oscillator starting. This service bulletin has been deleted, and service bulletin KMA-24-6 has been issued to implement additional changes to improve the starting capability of the marker receiver local oscillator. KMA 24-6 will provide a procedure for units that have not had KMA 24-5 incorporated as well as units that have had KMA 24-5 incorporated.

**KMA 24-6** (Applicable to s.n. 13315 & below) To improve marker receiver local oscillator starting. This is a warranty reimbursable mod for 2 hours if you find one under the above s.n. Parts required: Kit 050-02151-0000.

**KMA 24-7** (Applicable to P/N 066-1055-00 thru -03, SN 34038 and below.) To prevent hold down screw from damaging the KMA-24 frame making it difficult to remove unit from the mounting tray. This mod replaces the allen unit hold down screw with a new one which will allow for a frame stiffener. Parts required (Kit 050-03167-0000). Time required 1 hour. Warranty reimbursable if unit still under warranty.

## SERVICE AIDS:

**KMA 24-101** (Revised May 92) Component change of Q-102, Q-103, Q-104, and Q-105. Q-102 and Q-103 from 007-00153-0000 to 007-00161-0000. Q-104 and Q-105 from 0007-00335-001 to 007-00335-0002. When changing these transistors to the new type, all four must be replaced at the same time. R-114 must also be changed from a 10K resistor to a 51K resistor (131-00513-0023).

**KMA 24-102** (Revised Jan. 92) Increased current capability of the microphone key lines. Change CR-105 & CR-106 from a 1N916A diode to a 1N4003 (007-06025-0000). The 1N4003 has a higher forward current rating which is needed in some installations.

p73

**KMA 24-103** Output fuse F202 misprint in maintenance manual. F202 should be a 5 amp fuse (036-00057-0010)

**KMA 24-104** Marker receiver AGC adjustment. A product improvement has been made to improve AGC operation. This change was incorporated in s.n. 11005 and above. To incorporate this change in any s.n. below 11005, follow the procedure given below.

- 1. Place the unit on the bench and remove the top and bottom dust covers.
- 2. Locate and remove R-117, a 10K ohm, 1/8 w resistor
- 3. Locate the new R-117, a 5.1K 1/8 w 5% resistor, (130-00512-0012), and install one end of it into the solder pad that connects to the junction of CR-102 & R-116.
- 4. Locate the new adjustment pot R-229, (10K 133-00113-0019). Wrap the center lead of R-229 to one of the outside leads. It may be necessary to reposition C-110 so it lies flat against the board to make room for R-229.
- 5. Wrap and solder the 2 leads wrapped from step 4 to the open end of the new R-117.

Marker Receiver AGC Alignment, is required after this change has been incorporated.

NOTE: If R-229 is not incorporated in the unit, omit steps 1 & 6.

- 1. Turn R-229 all the way counterclockwise.
- 2. Apply a standard test signal of sufficient strength to cause an audio signal of about .5V peak at TP-101 with the marker sensitivity switch in the HI position.
- 3. Adjust T-104 & T-105 for maximum response at TP-101.
- 4. With the marker sensitivity switch in the HI position, adjust R-101 for receiver threshold while applying a standard test signal of 200 uv with 1300 Hz modulation.
- 5. Place the marker sensitivity switch in the LO position and adjust R-102 for receiver threshold while applying a standard test signal of 1000 uv with 1300 Hz modulation.
- 6. Note the AC voltage at TP-102. Adjust R-229 so that the voltage at TP-102 increases by 6db when the RF input signal is increased from 1000 uv to 50 K uv.
- 7. Adjust R-149 for 1Vrms at TP-102 while applying a standard test signal of 10,000 uv modulated with 1300 Hz.

**KMA 24-105** (Applicable to s.n. 8848 & below.) Q-101, FET SD305 is replaced by FET 3N312. Several circuit changes are required to accommodate this change.

- 1. Remove the top and bottom equipment covers.
- 2. Refer to Figure 6-2, P.C. Board Assembly in the maintenance manual.
- 3. Locate and remove Q-101. Replace it with F.E.T. 3N212 (007-00453-0000).
- 4. Locate and remove R-105. Replace it with a jumper.
- 5. Locate and remove C-103.
- 6. Locate and remove R-104.
- 7. Replace the top and bottom covers.
- 8. Perform a complete functional test.

**NOTES:**

FOR A COMPLETE SET OF "THE TECHNICIAN'S NOTEBOOK", CALL (616)798-2050

# The Technician's Notebook

By Jerry Gordon

# KN-62/A/64

Rev. 0, October 1999

**Weight:** 2.6 Lbs. Including mounting rack  
**Transmitter power:** 62A 100 watts nominal, 64 35 watts nominal.  
**Acquisition sensitivity:** -82 dBm minimum, -87 dBm nominal  
**Maximum altitude:** 50,000 feet  
**Power requirements:** 11-33 VDC at 15 watts.  
**Range accuracy:** ± nautical mile, Ground speed accuracy ± 1 knot.

---

## SERVICE BULLETINS:

- KN-62-1** (applicable to serial number 1300 and below) Elimination of inverter noise from the BCD code select lines and the video of the IF. Addition of two capacitors to the unit. Requires mod kit KPN 050-1724-00. Time required 1.5 hours.
- KN-62-2** (applicable to serial number 2526 and below) Prevention of erroneous channeling from isolation diode leakage in external control heads. Provides a pull up resistor for the common line of the remote control head. Requires mod kit KPN 050-1759-00. Time required 1.5 hours.
- KN-62-3** (applicable to serial number 3940 and below) Prevention of synthesizer latchup when changing channels by VCO tuning voltage dropping to 0 volts instead of the normal 5. The mod consists of adding one diode. Requires diode 1N4154 KPN 007-6016-00. Time required 1.5 hours.
- KN-62-4 KN-62A-1** (applicable to serial number KN 62 serial number 5320 and below, KN-62A serial number 10291 and below) Prevention of damage to the transmitter and modulator from electrostatic charges. Consists of installing a coil between the antenna center conductor and ground. Requires one 5-turn coil KPN 019-02110-0002. Time required 1 hour.
- KN-62A-2** Superseded by mod 3
- KN-62A-3** (Applicable to serial number 26,782 and below). Improvement of AGC operation. Change values of R-332 and R-358 on the RVTTS board. Replace R-332 with a 390K ¼ watt resistor (131-00394-0023) and R-358 with a 15K ¼ watt resistor (131-00153-0023). Time required: 1 hour.
- KN-62A-4** (Applicable to KN-62A part number 066-1068-00/01/02/03 serial numbers 26894 and below. Serial numbers above this have mod 4 incorporated at manufacture. Prevention of spurious frequency transmissions. Consists of cutting and removing two paths on the transmitter board and replacing them with ferrite beads and buss wire. Time required 1.5 hours.
- KN-62A-5** (Applicable to KN-62 A part number 066-01068-0000/1/2/3, serial number 27044 and below.) requires reworking of the main board and the RVTTS board. Requires 1 mod kit KPN 050-03192-0000. Time required 2.5 hours. Provide image frequency protection from TACAN.
- KN-64-1** (Serial numbers 21229 to 22399 had mod 1 incorporated during manufacture). This is an information only bulletin. Mod 1 could cause AGC to lock up and is no longer recommended. See mod 2 for further information.
- KN-64-2** (applicable to serial number 21,229 to 22,399) Improvement of AGC operation. Changes values of R 332 and R 358 on the RVTTS board. Recommended only if problem exists. Unit must be at mod 1 status before installing this bulletin. Consists of changing the values of R 332 and R 358 on the RVTTS board. See Service Bulletin KN-62A-3.
- KN-64-3** (applicable to serial numbers 23578 and below). Prevention of spurious frequency transmissions when transmitting into high SWR loads. Recommended for transmitter board 200-05916-0001 only. Cut and

## KN-62/62A/64 Technician's Notebook

remove two paths on the transmitter board and replacing with buss wire and ferrite beads. Time required 1.5 hours. Parts required: 3 ea. 013-00006-0000 ferrite beads, 2 ea. 026-00028-0000 buss wire, .75 in long, and RTV as required.

### SERVICE AIDS:

- KN-62-101** Main board and RVTTTS board interchangeability. Both boards are interchangeable from the KN-62 and KN-62A, although they have different part numbers. Note: if the KN-62 main board is installed in a KN-62 A, the TSO for the KN-62 A will be void.
- KN-62-102 KN-62A-101** Divide by 64 prescaler 120-04009-0001/02 no longer available. The replacement IC is KPN 120-04014-0000. Replacement of the IC requires rewiring of the input voltage. See the service aid for instruction.
- KN-62-103 KN-62A-102** VCO board 200-05911-0000 replaced by 200-05911-0010. This is a product improvement to minimize the possibility of the VCO frequency pulling.
- KN-64-101** divide by 64 prescaler 120-2009-01502 no longer available. Replacement IC is 120-04014-0000. It is mechanically interchangeable, but requires rework to change the +VCC input from +6.8 VDC to +5 VDC. Check the service aid for directions for the rework if necessary.
- KN-64-102** VCO board 200-05911-0000 replaced by 200-05911-0010. This is a product improvement to minimize the possibility of the VCO frequency pulling. See Service Aid KN-62-103.

### SERVICE MEMOS:

- Service memo 299** KN-62 A lead configuration change for transistor 007-0113-00.
- Service memo 310** KN-62/62A/64 gas discharge display update.
- Service memo 326** KN-62/62A/64 improved high voltage display drivers.
- Service memo 137** KN-62/62A/64 revised interconnect diagrams detailing suppression pulse output.

### INSTALLATION BULLETINS:

- Installation bulletin 137** KN-62/62A/64 revised interconnect diagrams detailing suppression pulse output.
- Installation bulletin 138** KN-62 interface with a Narco NAV 122 NAV receiver.
- Installation bulletin 143** KN-62/62A cooling requirements.
- Installation bulletin 224** KN-62/62A/64 compatibility of the KNS 81 and KN 62/62 A/64.
- Installation bulletin 225** KN-62/62 A/64 dual NAV interface to the KN 62/62 A/64 when one NAV is serial tuning and the other is parallel tuning.
- Installation bulletin 226** KN-62/62 A/64 NAV 1/NAV 2 channeling of a KN 62/62 A from two KX 155/165s.
- Installation bulletin 254** KN-62/62 A/64 optional mounting to prevent RFI from the KN-62/62A and the KR-85/86 ADF systems.
- Installation bulletin 287** KN-62/62A installation problems with dual DME's tuned to frequencies 5.30 megahertz apart.

### THE FOLLOWING COURTESY OF DAVE STOUT AND JOE TAIBI – ALLIED SIGNAL

- If the TX is weak or non-existent, and the modulator pulses are distorted, look at C-116 with an AC coupled scope. If there are nice negative going modulator pulses larger than about ¼ volt, C-116 is leaking.
- When the flex cables start to peel, replace them. Resealing the cables with RTV as an example is not a good fix.
- If the RX is weak, check the suppression pulses. If they are also bad, look at I-201 inputs and outputs as a possible problem.
- Handy things to have around: Keep a known good set of LSI's around. They can cut the troubleshooting time way down.
- For those "Old Timers" the "Sniffer" works well when troubleshooting the DME's.

## THE "SNIFFER"

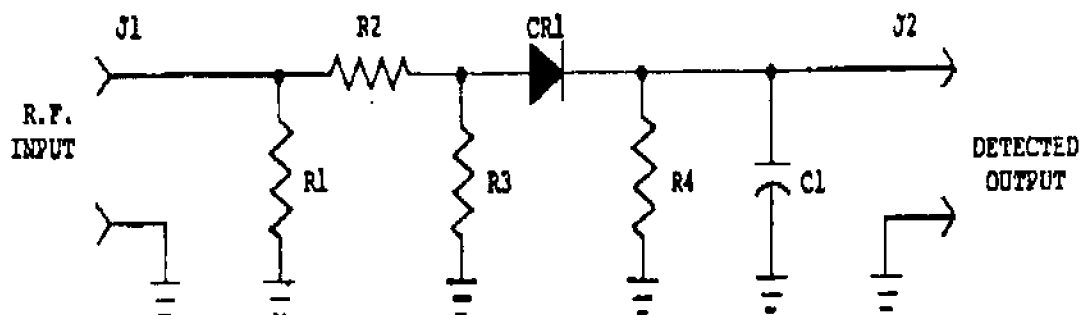

ITEM	KPN	DESCRIPTION
C-1	104-00001-0047	Capacitor Mica, 18 pf.
CR-1	007-06086-0000	Diode HP-2303
J-1	030-00071-0000	Jack, Subminiature
J-2	030-00030-0001	Jack, BNC
R-1	130-00620-0023	Resistor 62, 1/4w 5%
R-2	130-00271-0023	Resistor 270, 1/4w 5%
R-3	130-00620-0023	Resistor 62, 1/4w 5%
R-4	130-00332-0023	Resistor 3.3K, 1/4w 5%

### ASSEMBLY:

- 1 Assemble in a small box. (An old KN 65A tube assembly works well) making all leads as short as possible. Use minimum heat in soldering CR1.
2. The output is connected through shielded cable to the oscilloscope vertical input. The d.c. level (c.w.), or peak voltage (pulsed r.f.) is indicative of the r.f. input.
3. The input may be directly connected through coax to low level r.f. inputs (less than a few watts c.w. or several hundred watts pulsed).
4. For stripline use, a pickup loop may be used. Form the end of a subminiature cable into a 1/4" diameter loop, soldering the center conductor to the shield. We suggest the cable length be one wave length which is 7 5/8" (19.3cm) of RG 188/U. The pigtail from a KN 65A anode assembly would be suitable. **IMPORTANT NOTE:** Be sure the entire loop is well insulated, by tape or shrink tubing.

### USE:

1. You can measure c.w. of as low as 2-3 mw by measuring the d.c. voltage on the output. Pulsed power can be measured by measuring the peak voltage seen on the oscilloscope. This is NOT intended to be, and CANNOT be, an accurate measurement device. Useful comparisons may be made between good radios and bad radios. It may be used for tuning Purposes by tuning the assembly under test for maximum detected output and for a flat pass band response throughout the DME band.
2. To use it with stripline circuits, use the pick-up loop and hold the loop parallel to the surface of the path. Move the loop along the path to find the point of maximum coupling. Since the exact voltage induced varies with many factors, this is mostly a "GO/NO GO" test to locate the dead transistor, switching diode, or circuit branch.
3. Putting a 50 ohm termination resistor across the output will make the output wave form more accurate, but this cannot be used for measuring rise and fall times. A 50 ohm termination also increases the amount of power the diode must dissipate, making it more easily damaged. The Output voltage seen by the oscilloscope will be greatly reduced as well.
4. Excessive input can burn out the detector diode. Too much average power (such as a transponder with 7777 and 1200 replies/sec), or too much peak voltage (such as greater than 100-200 watts) may exceed the limits of the diode.

**NOTES:** Don't forget to check the regulators on the modulator board: 5Volt I-102 and 9 1/2 Volt I-103. Fuse in the front panel. 3 A (036-00058-0003) Display (037-00056-0000).

# The Technicians Notebook

By Jerry Gordon

# KN-65/65A

Weight KN-65 - 7.6 lbs. KN-65A - 8.5 lbs. KI-265 - 1.0 lbs.

KA-43 - .4 lbs. Operating altitude to 30,000 feet.

Accuracy + - .5 nm or 2%, whichever is greater.

Transmitter power 100 watts peak. Acquisition sensitivity -78dbm, 4 out of 5 searches.

Ground speed accuracy + - 5 knots or 5%. Audio 50mw @ 600 ohms. Output 20mv per nm.

Revision No: 1 6/1994

## SERVICE BULLETINS:

KN65-1 (Applicable to S.N. 1024 & below) If you have one that old, look up the bulletin.

KN65-2 (Applicable to S.N. 2574 & below) C441 in IF AMP/DECODER replaces with .68@20v tant. (096-0130-0014) Time required. 1 hour.

KN65-4 revised 3/9/79 (Applicable to S.N. 3335 & below) Change C107 & R108 & add R170 on P/S ENCODER board.

Kit 050-01329-0000 - Time required. 1.5 hours.

KN65-5 (Applicable to S.N. 4793 & below) Kit 050-01333-0000 - Time required. 1 hour.

KN65-6 (Applicable to S.N. 3177 & below) Look up if applicable.

KN65-7 (Applicable to S.N. 5269 & below) Kit 050-01405-0000 - Time required 1.5 hours.

KN65-8 revised 10/14/75 (Applicable to S.N. 7975 & below) Speed run-up and dead memory range problems associated with Q-532 when range offset cannot be zeroed properly. Time required 1.0 hour.

KN65-9 Cooling. Installation of fan. Kit 050-01599-0000 - Time required 5 hours.

KN65-10 Ground speed pre-select mod. Time required 1 hour.

KN65A-1 None assigned to this number.

KN65A-2 (Applicable to S.N. 14644 & below) Kit 050-01561-0000 -Time required 3 hours.

KN65A-3 revised 9/3/76 (Applicable to S.N. 14822 & below) For 13.75 volt installation. Kit 050-01580-0000 Time required 5 hours.

KN65A-4 (Applicable to S.N. 16760 & below) Requires one 130-00471-0023 ( 470 @ 1/4w 5% resistor) Time required 1 hour.

KN65A-5 (Applicable to S.N. 19069 & below) Glide Slope pulled up on turn on. Kit 050-01657-0000- Time required 1 hour.

KN65A-6 (Applicable to S.N.20350 & below) Requires one each of (007-00244-0000) and (007-00342-0000) for Q118 & Q116. Time required 1.5 hours.

KN65A-7 (Applicable to S.N. 21000 & below) Kit 050-01725-0000-Time required 1 hour.

KN65A-8 revised 3/15/79 (Applicable to S.N. 20150 & below) Reduce Ground Speed runaway. Kit 050-01737-0000-Time required 1 hour.

KI266-1 (Applicable to S.N. 2120 & below) Elimination of radiation for KI-266. Added steel cover on T101. 047-04063-0000-Time required .5 hour.

## SERVICE MEMOS:

119 Special test equipment for servicing KN61, 65, 65A.

129 revised 7/12/76 SCR's are color coded and must be replaced in pairs or replaced with same color SCR.

KN65 SCR	007-6036-10	Brown	SCR TS/R-8
KN61&65A	007-6101-01	Yellow Dot	SCR 2N6397
	007-6036-15	Red	SCR TS/R-8
	007-6101-02	Green Dot	SCR 2N6397
	007-6036-20	Orange	SCR TS/R-8
	007-6101-03	Red Dot	SCR 2N6397
	007-6101-04	Blue Dot	SCR 2N6397

144 KN65/KI265 service hints. C525 in video processor. Replace old style yellow spongy one with KPN 108-05020-0000. KI 265 read-out display sticking, warning flag sticking, and range /groundspeed read-out slippage.

148 revised 12/9/81 (Applicable to S.N. 5313 & below) To make unit compatible with KI266 Indicator. See documentation for details.

203 KPN 007-0134-00 No longer available. Used as Q207, Q208 in KN65. RB 007-0236-00 (leads are different)

222 Cancellation of Silver Star modification.

225 revised 2/3/78 KPN 007-0119-01 No longer available. Used as Q201 in synthesizer. RB 007-00238-0000 (KPN 4917)

**INSTALLATION BULLETIN # 99** Do not parallel panel-mounted re-channel warning lamp with pin J of the KI266 Indicator. (Pin J unused in KN65)

<b>TIPS AND HINTS: COURTESY OF BENDIX/KING PRODUCT SUPPORT</b>
--

**KN65A POWER SUPPLY MODULATOR:**

Intermittent power supply adjusting pots are a common problem. (R107, 122 & 125) Causes intermittent ground-speed run-up. DC voltage on the pre-regulator (Q101-collector) should be about + 10V for a 14V unit, and 20V for a 28V unit. The adjustment pot is R107. Adjust R107 for + 5.2 on + 5.2 line.

Indicator power circuit: Q116 & Q118 have been updated to improve reliability.

SCR'S: Q128 & Q129 can cause the same problems as in the KN65 power supply; incorrect pulse spacing, or loss of one or both TX pulses. Check HV mod as per KN65 P/S board.

Fan circuit: Q114 is a common failure. If this is bad the fan motor could very well be bad. If the fan motor is bad, the new Q114 will fail after a short time. If the fan stops, the P/S board may burn.

Transistors Q102, 104, 110, 112 & 107 are often installed up-side down when replaced in the field. This naturally causes problems. C158 & 159 can cause inverter to not run, or draw high current. See KN65 Power Supply for HV mod testing, etc.

**KN65 POWER SUPPLY MODULATOR:**

A common problem is erratic groundspeed run-up. (often going above 400kts). This is usually caused by CR 105 & 104. (bridge rectifiers) Although it seems to be a video processor board problem, this is seldom the case. This symptom can also be caused by CR112, CR109, CR115 or any of the power supply filter caps.

If SCR101 & SCR102 do not have matched turn-on times (due to component age), the transmitter pulse spacing will be out of spec, possibly causing erratic lock-on. These should be replaced with parts having matched color dots. (See service memo 129)

A failure of either SCR will cause one transmitter pulse to be missing and therefore no lock-on. A good test for this is to measure DC voltage on the anode (case). It should be approx. + 195VDC when unit is in standby. If one is bad, both should be replaced. The power supply adjustment pots (for + 5.2V, + 15V & -15V) can be intermittent, and should be replaced if any trouble is noted with them. They are often ok until adjustment is required. When setting up power supply voltages, + 5.2V should be set first. Then adjust + 15V, then -15V. The plus & minus 15V supplies should be closely balanced.

Q101 & Q102 (P/S switchers) can cause unit to reset as soon as it locks one-due to power supply sag.

If P/S inverter is not running, lift all power transformer secondary leads from power supply board. If inverter runs, there is an excessive load on one or more of the secondary lines. If it still does not run, the problem is in the inverter.

If there is very low or no transmitter power, check for the presence of high voltage modulator pulses. They should be 1800 V p-p, and should be checked with a suitable HV (X100) scope probe. A quick test can be made by clipping the scope probe (X10) over the insulation of the HV mod wire. The scope should pick up enough to see the waveform.

There is an update to allow a KN65 to work with a KI266 indicator. (See service memo 148) This is called the power supply special mod. It increases the current available on the + and - switched indicator supply lines.

If HV modulator pulse is bad the anode of the PA or doubler tube could be arcing.

**KN65A SYNTHESIZER BOARD:**

I201 & I204 should have jumpers from pins 1 to 16. This puts + 5.2 on pin 1. Without this, the "loop" waveform may be jittery. No loop, no RX or no TX-check Q216, Q217, & Q218 emitter for about .3 to .5V. If zero, transistor is open.

If receiver sensitivity is erratic (video level changes)- Preselector & L.O. tuning voltage adj. pots may be intermittent. This is a fairly common problem.

If a problem is suspected on this board always check X enable, Y enable, and both hi/lo band switching lines. (I214 pin 1 & I214 pin 2) These should be the inverse of each other.

I201 & I204 can cause one or more channels to be inop.

**KN65 SYNTHESIZER BOARD:**

I204 & I205 should have a jumper from pins 1 to 16. This is especially important if they have ever been replaced. This puts + 5.2V on pin 1. Without this, the synth. loop may be "jittery". Common failures on this board are I204 & I205. (causes one or



more channels to be inop.) Q206, Q207, & Q208 can cause loss of synth loop, no receive or no transmit. A quick check is to look at the emitter voltage. It should be around .3 to .5V. If zero, transistor is open.

All pots can be intermittent, especially if they are adjusted.

When a problem is suspected on this board, always check X enable, Y enable, and both hi-lo band switching lines. (I210 pin 14 & Q210-collector) One of these is the inverse of the other.

TX drive output should be about 2.5MW CW.

L.O. Drive output should be about 5MW CW.

L.O. tuning voltage should be adjustable from + 15 to + 21V.

Preselector tuning voltage should be adjustable from + 13 to + 26V.

L.O. tuning & preselector tuning voltage should be adjusted for optimum receiver, instead of absolute values of voltage. Monitor detected output of IF Amp (RX video) and adjust L.O. & preselector tuning voltages for max. signal on all channels.

#### **KN65 IF/VIDEO DECODER (OLD STYLE BOARD):**

The old style IF board can be recognized by the number of IC's on the board. The old board has only (3) IC's. Of these 3, I402 & I403 are no longer available. If one or both of these are bad, a new style IF must be used to replace the IF board.

Weak IF amp FETS can cause a loss of 1 or 2 DB in RX.

If IF has no "grass" (background noise), make sure decoder suppression & channel change are not always high. A failure of 51.6 MHZ L.O. causes no "grass". Grass level should be adjusted (W/AGC pot) for .5VP-P level on noisiest channel. Unit should go into standby with no input signal. If not, grass level may be too high.

#### **KN65 NEW STYLE IF BOARD, KN65A IF BOARD:**

This has more IC's than the old board and works with a higher video level than the old board. IF low "grass" level, C452, C453, C454 & Q415 are good suspects. Weak IF AMP FETS can cause a loss of 1 or 2 DB of RX. If decoder suppression or channel change is always high, there will be no grass level or RX. A failure of 51.6 mhz L.O. will cause no grass or no RX.

#### **R/T BOARD-SOLID STATE DRIVER KN65, KN65A:**

Make sure TX buffer is OK (on synth). C724, C719, & C713 can cause low power. Especially if the old style. (orange rubber ring around base of part). Do not run SSD with back cover removed as Q702 will overheat.

C702, C704, C709, C710, C716, C721 & C715 (de-coupling feed-through caps) can cause low power.

SSD output should be around 8W, depending on the gain of the tubes. 5W may be enough. Q701 & Q702-class A stages 10DB gain. Q703 & Q704-pulsed stages 9DB gain. Doubler tube output should be 12W. PA tube output should be 150W. Final output should be 100 W (KN65), 125W (KN65A)

Make sure L.V. modulator from P/S is OK.

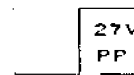

#### **R/T BOARD-PRESELECTOR KN65, KN65A:**

CR705, CR707, CR708, CR709 & CR710

(matched varactor set) Can cause weak RX. Check for leaky feed-through caps while varactors are out.

CR706-mixer diode. Should have 100MV on TP703 all across band. The adjustment of synth & preselector will affect this.

Duplexer diode failure can cause low power or TX freq problems.

Check for duplexer drive waveform.

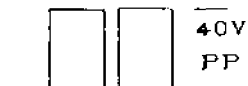

Check output of L.O. buffer on synthesizer board. C738 & C737 in L.O. quadrupler can cause weak RX.

#### **VIDEO PROCESSOR KN65, KN65A:**

If C525 is old style (yellow cap) and is soft & spongy, replace. Unit will stay in standby if TP502 has less than 8.1VDC. Range offset adjustment can cause this.

TP520 is Hi in stby and Lo out of stby. Groundspeed problems are usually P/S faults.

If speed monostable output is at least .82 sec., and G/S is low, problem is speed filter or speed buffer.

If modulator enable is missing, problem is on V/P board or P/S board. To determine which:

Lift second pulse sent wire from video processor board. Jumper TP522 (modulator enable) to TP525 (second pulse sent). If modulator enable is ok, V/P board is ok. If not, V/P board is bad. Problem on P/S could be no second pulse sent. Make sure unit is not in stby, or will not transmit. Ground stby over-ride to be sure.

Terminal No. 1	KN-65	KN-65A
2	+ 15 cont.	
3	-15 cont.	
5	+ 27.5 v	+ 15 cont.
6	-15v	-15 cont.
7	+ 22v	+ motor
8	+ 15v	-15v
9	-motor	+ 15v
10	+ 5.2v	
11	+ motor	- motor
12		+ 22v
13		+ 27.5v
14	+ 3.6v	
15		+ 3.6v
		+ 5.2v

NOTES:

# The Technician's Notebook

By Jerry Gordon

# KN-72/KN-77

Rev. 2, Nov 1999

**KN-72:** Weight 1.1 lb. Accuracy  $\pm 1$  degree

**Input (Standard):** .5 vrms @ 60k ohm. Loads: 5 ea. -1 K Deviation

3 ea. -1K Flag, 3 ea. -200 ohm To/From

**KN-77:** Weight: 2.2 lb. 2.7 lb. with rack and connector

VOR accuracy: 1 degree

**Input (Standard):** 5vrms @100k ohm, Loc .35vrms. Loads: 3 ea. -1 K Deviation

-3 ea. -1K Flag, 2 ea. - 200 ohm To/From

## SERVICE BULLETINS:

**KN 72-1** (applicable to sn 1655 and below) To provide adjustment in the Reference Filter Ckt. Kit: 050-01699-0000 Time required: 1 hour.

**KN 72-2** (applicable to sn 2365 and below) Replacing pots with more reliable type. (Intermittent operation) Kit: 050-01761-0000. Time required: 2 hours.

**KN 72-3** (applicable to sn 2365 and below) To eliminate VOR errors and excessive VOR course width when used with some non-King NAV receivers. Parts required: 4 ea. 096-01014-0000. Time required: 1 hour.

## SERVICE MEMOS:

**SM # 230 KN 72 Service Hints:**

Load resistors are not required for the indicator outputs of the KN-72 converter. Alignment procedure changes: Step E and step Y of the KN 72 alignment procedure, paragraph 6.2.2, page 6-1 of the manual should read: E. Set R200 for maximum AC voltage at TP4. Adjust R146 for  $1.5 \pm .1$  vrms at TP4, Y. Set R140 for 125mv of flag drive. The R200 referenced in step E is an addition to the KN 72 and its physical location is adjacent to TP2 and TP6. R200 is a 5K variable resistor, KPN 133-00113-0016. The KN 72/KN1 520 interconnect wiring diagram in the KN 72 installation manual, contains the following errors. Page 2-8, figure 2-4 should show STATOR F connected to PIN F and STATOR G connected to PIN E on the KNI-520.

**SM # 235 Improved tracking capacitors:** Capacitors affected are C127, C128, C138, C139. They must be replaced in matched sets of four. Parts Required: 1 ea. 108-06005-0010 (this is a set of 4).

## SERVICE AIDS:

**SA KN-72-101** Change to the final test data sheet. In the Maintenance Manual, page 6-2, par 6.2.3, step E, change the value as follows:

From: Generator = OBS Setting \_\_\_\_\_ mV 400mV  $\pm 30\%$

To: Generator = OBS Setting \_\_\_\_\_ mV 300mV  $\pm 30\%$

**SA KN-72-102** Replacement of obsolete IC I-107 voltage regulator (8.5V). UA78GC (120-03066-0002) is no longer available. Use 120-03126-0016. Requires circuit changes. See SA for details.

## SERVICE BULLETINS:

**KN77-1** (applicable to sn 2762 and below) Standardization of the load impedance to the NAV receiver to eliminate special calibration of the composite levels. Kit: 050-01374-0000. Time required: 3 hours

**KN 77-2** (applicable to sn 6700 and below) To provide extra flag current for digital flag systems. Kit: 050-01494-0000. Time required: 3 hours.

**KN 77-3** (applicable to sn 8699 and below) To provide dual time constants to the indicator "D-bar" in VOR/LOC mode. Mod 2 must be done prior. Kit: 050-01495-0000. Time required: 2 hours

**KN 77-4** (applicable to sn 10510 and below) To reduce the effects of strong RF during transmitter operation causing erratic needle and flag. Kit: 050-01635-0000. Time required: 2 hours

After Service Bulletin has been performed the installation must be modified to include shielded pair type wire in the instrumentation lines with the shields tied to pin CC of the KN 77. The shields must be left unterminated at the indicator end.

# The Technician's Notebook

By Jerry Gordon

# KN-73/KN-75

**KN-73:** Weight: 2.0 lb., 2.5 lb. with mount and connector.  
Channels: 40, Sensitivity: 40 uv for 60% of standard deflection.  
Output: 3 ea. 1 K deviation loads, 2 ea. 1 K flag loads.  
**KN-75:** Weight: 1.5 lb., 1.6 lb. with mount and connector.  
Channels: 40, Sensitivity: 20uv for 60% of standard deflection.  
Output: 8ea. 1 K deviation loads, 9ea. 1 K flag loads.

Rev. 2, Jan. 2000

---

## KN-73 SERVICE BULLETINS:

**SB 73-1** (applicable to sn 2019 and below) Unavailability of transistor (007-00134-0000). Service bulletin describes the replacement procedure if Q105, Q106, Q107, or Q108 fails.

**SB 73-2** (applicable to sn 5742 and below) To lessen effects of prop modulation. Change C-183 and C-184. parts required: 2 ea. 096-01030-0005. Time required: 1 hour.

**SB 73-3** (applicable to sn 7826 and below) Replacement of Q103 (007-00119-0000 no longer available.) with 007-00119-0001 requires a circuit change. Parts required: 2 ea. 007-00119-0001 and 1 ea. 007-06035-0000. Time required: 1 hour.

## KN-75 SERVICE BULLETINS:

**KN 75-1** (applicable to sn 1902 and below) To reduce radiation on 126.00 mhz if problem with com breaking squelch arises. Check documentation if this problem arises.

**KN 75-2** (applicable to sn 4202 and below) To reduce severe G/S needle deflection during initial turn on. Parts required: 1 ea. 096-01030-0006. Time required: 1.5 hours.

**KN 75-3** (applicable to sn 4972 and below) To eliminate the possibility of a G/S flag and deviation while on a VOR frequency. Kit: 050-01783-0000. Time required: 1.5 hours.

**KN 75-4** (applicable to sn 5509 and below) To allow the use of different FET's when Q-101 or Q-102 needs to be changed. (IF MFE 521 KPN 007-00310-0000 is not available) SEE SERVICE AID KN 75-101

## SERVICE AIDS:

**KN 75-101** Replacement of Q-101 and Q-102. Field effect transistor SD306 is no longer available. It is replaced by Field effect transistor MFE521. Q101 and Q102 must be of the same type. This AID describes the procedure for changing these transistors over to type MFE521 and selecting the correct bias resistor for R107.

**KN 75-102** Replacement of obsolete field effect transistor 3N225, KPN 007-00281-0000. If replacing Q-103 or Q-117 check with this AID for the procedure.

**KN 75-103** Replacement of obsolete IC voltage regulators I-111& I-112. UA78GC (120-03066-0002) is no longer available. If replacement is necessary, use 120-03126-0016, and follow the procedure listed in this Service Aid.

## NOTES:

## The Technician's Notebook

By Jerry Gordon

# KNS-80

Rev. 2, Sept. 1999

**Weight:** 6.0 Lbs. including rack and connector.

**Receiver sens.** 2.0  $\mu\text{v}$  for 6db s+s/n (With 6 dB pad). 2.0  $\mu\text{v}$  for full flag. (VOR & LOC).

**VOR accuracy:** <.6 degree, AGC 5  $\mu\text{v}$ -20K  $\mu\text{v}$  < 3 dB and <.3 degrees VOR error from

10  $\mu\text{v}$  to 10K  $\mu\text{v}$ . **Audio:** 50mw @ 400 ohms. G/S rec. < 16  $\mu\text{v}$  for 60% of std deflection. **RNAV** cross track accuracy <.5 nm error.

Along track error <.5 nm. **DME** 50 watts peak minimum, 100 watts nominal. **Acquisition sensitivity** -82 dbm min, -87 dbm nominal.

**Range accuracy**  $\pm$ .2 nm 0-99.9,  $\pm$ .3 nm 100-199 miles.

---

### SERVICE BULLETINS:

**KNS-80-1** (Applicable to SN 2169 & below) To prevent DME staying in search mode with no information. Parts required: 1 ea. 007-46016-4000. Time required: 1.5 hours.

**KNS-80-2** (Applicable to SN 2327 & below) To prevent loss of memory when power is turned off. Parts required: 1 ea. 130-00103-0023 10k  $\frac{1}{4}$ w 5% resistor. Time required: 1.5 hours.

**KNS-80-3** (Applicable to SN 3884 and below) To improve auto pilot tracking with the KNS 80 in the approach mode. Parts required: 1 ea. 120-02025-0005 Integrated Circuit 120-02025-0006, Integrated Circuit 131-00223-0023, Resistor (22K,  $\frac{1}{4}$ w 5%), Time required: 1.5 hours, including testing.

**KNS-80-4** (Applicable to SN 3873 and below) To prevent electrostatic build-up and arcs from the antenna, damaging the transmitter and modulator assemblies in the DME section. Parts required: 1 ea. 019-02119-0002 5 turn coil. Time required 1 hour.

**KNS-80-5** No service bulletin was issued for #5.

**KNS-80-6** (Applicable to SN 5708 and below) COM keying and RFI protection for VOR/LOC and glideslope converters. Parts required: 1 ea. 113-03121-0000, 120pf@500V 5% capacitor. Time required: 2 hours.

**KNS-80-7** (Applicable to SN 5650 and below) To correct excessive alignment drift of the VOR converter. Parts required: 1 ea. 108-06005-0010, 1 $\mu\text{f}$  @50V 5% capacitor. Time required: 2 hours including testing.

**KNS-80-8** (Applicable to SN 6669 and below) Better tolerance of low temperature. Parts required: 1 ea. 097-01501-0035 500  $\mu\text{f}$ @16V capacitor, 130-00100-0023 10 ohm  $\frac{1}{4}$ w 5% resistor, 130-00101-0023 100 ohm  $\frac{1}{4}$  w 5% resistor. Time required: 1.5 hours including testing.

**KNS-80-9** (Applicable to SN 7545 and below) To prevent RFI interference from the KNS-80 power supply in some ADF's. Parts required: 1 ea. 050-01907-0000 Kit. Time required: 3.5 hours including testing.

**KNS-80-10** (Applicable to SN 6809 and below) erratic operation of converter board due to vibration. Parts required: 1 ea. 050-01876-0000 Kit. Time required: 2 hours including testing.

**KNS-80-11** (Applicable to SN 7780 and below) To stop the VOR/LOC D-Bar from showing offset in certain auto pilots. Parts required: 1 ea. 130-00472-0023 4.7K ohm  $\frac{1}{4}$  w 5% F/C resistor. Time required: 1.5 hours including testing.

**KNS-80-12** (Applicable part number 066-4008-00 through 066-4008-03 SN 17731 and below). To prevent spurious frequency transmissions when transmitting into high SWR loads. Recommended for units with transmitter board 200-05916-0001 only. Involves cutting traces and replacing with buss wire and ferrite beads. See Service Bulletin KN-64-3. Time required: 1.5 hours.

**KNS-80-13** (applicable part number 066-4008-00 through 066-4008-03 SN 18055 and below). To eliminate spurious radiation from the glideslope receiver that may desensitize the nav receiver and cause a tone in the nav audio at 109.5 MHz. Consists of cutting a path, replacing a resistor and capacitor, adding a capacitor, resistor, and a circuit jumper. Parts required: Kit 050-03342-0000. Time required: 2.0 hours. See the bulletin for details.

### SERVICE MEMOS:

**SM 244** KNS 80 display flavors. Size change. (050-01802-0023) Be sure to check the display part number before installation.

## KNS-80 Technician's Notebook

SM 325 KN580 tracking capacitors for VOR/LOC converters. Better tracking over temperature. Assembly 200-05993-0000. C1102, C1103, C1109, C1110 capacitors affected.

### SERVICE AIDS:

**SA KNS-80-101** (Applicable to Digital Area Navigation System) Erratic or intermittent operation due to shorting of J1101 and J1102. Parts required (012-01005-0005 bulk quantity) Mylar tape, (012-01169-0000 1 x 3 1/4") individual strips of Mylar tape.

**SA KNS-80-103** (Applicable to Digital Area Navigation System) Replacement of I1013 and I1014. Replacement information: I1013: 120-02025-0000 is replaced by 120-02025-0005. I1014: 120-02025-0003 is replaced by 120-02025-0006. 120-02025-0004 is replaced by 120-02025-0006.

**SA KNS-80-104** (Applicable to SN 11235 and below) Distance Measuring Equipment Discontinuance of the divide-by 64 prescaler IC, 120-04009-000I/-0002.

**SA KNS-80-105** (Applicable to SN 10599 and below) Digital Area Navigation System changes required to accommodate Beckman Displays.

**SA KNS-80-106** Digital Area Navigation System. Replacement of obsolete field effect transistor 5D305 and 3N225.

**SA KNS-80-107** Digital Area Navigation System. VCO Board 200-05911-0000 replaced by 200-05911-0010. Product improvements to minimize the possibility of VCO frequency pulling.

**SA KNS-80-108** Some problems have been traced to intermittent connections between IC chips and their sockets. IC sockets on the computer board for I-1010 through I-1018 have been eliminated in production of new units. If this problem is suspected the IC's may be unplugged, the sockets removed, and the IC's soldered directly into the board.

**SA KNS-80-109** Discontinued transistor Q-108. Old PN 007-00226-0000 replaced by 007-00243-0000. This transistor is a direct replacement.

**SA KNS-80-110** Replacement for obsolete capacitor C-1107 (108-06001-0003) on the converter board 200-05993-0000. There is no direct replacement. The two options are:

1: Replace C-1107 with 111-00002-0008 and replace I-1103 with a new IC 120-06038-0012, which should be marked with a green dot.

2: Replace C-1107 with 111-00001-0074 and replace I-1103 with a new IC 120-06038-0022, which should be marked with an orange dot. Perform alignment and functional test in accordance with the maintenance manual.

### COMMON PROBLEMS INCURRED AT MANUFACTURER REPAIR LEVEL

#### • ERRATIC DISPLAY

Check inter-connecting pins between boards changed to gold plated. Mod 10. Computer board IC sockets intermittent (recommend shipping to the factory for this repair)

#### • ERRATIC MEMORY OPERATION

Check battery voltage, battery holder contacts, and continuity of interconnecting circuit to memory chip IC-1010. Check for 2.7 volts at pin 18 of IC-1010. If battery voltage is OK, replace IC-1010. If frequency comes up on 110 MHz or something other than what it should, turn unit off then on and see if the receiver will lock up. If so, and battery is OK, change IC-1010.

#### • CHANNEL SELECTOR DOESN'T CHANGE FREQUENCY OR CHANNELS DOWN INSTEAD OF UP OR UP INSTEAD OF DOWN.

Replace switch.

#### • CDI "WINDSHIELD WIPERS" AND TO-FROM FLIPS.

Bench test unit. If OK on bench, ohm out OBS lines from indicator to rear edge connector of panel unit. A very small resistance caused by dirty pins or bad wiring can be the cause. Also check output of 30hz squaring amp (should be phased locked with input signal using 30hz for scope trigger.) (IC 1104 is sq. amp) Check FM discriminator circuit for this type problem as well. Check variable adjustment pots for "noise".

#### • SYSTEM. CHECKS OK AT 14V BUT WILL SHUT DOWN AT HIGHER VOLTAGE.

Check capacitor C106 in current limiter circuit.

• **DME CHECKS WEAK ON RX AND TX.**

Replace diodes CR-604 and CR-605 in output of trans/input to RX. For DME transmitter problems, use "sniffer" as shown in maintenance manual. Check for distorted output at Q-603 and Q-605. C-608 (15pf) may be open. This cap is located in area of Q-603 and Q-604. A quick check method is to make up a jumper cap.

• **DME WILL NOT LOCKUP OR TAKES EXCESSIVE TIME TO DO SO.**

Check test-point 202. Adjust base line voltage for -.5V (R-237). If base line voltage responds in steps, it could indicate a problem with AGC circuits.

• **NOTE: TO REPLACE THE SMALL CHANNELING SWITCH.**

Use 231-00080-0011. This is the switch that is activated from the small channeling knob.

LIST OF THE MORE COMMON PARTS

DESCRIPTION	PART NUMBER	DESCRIPTION	PART NUMBER
S'CL4046	120-06038-0000	Batteries	015-00048-0001
S'CL4049	120-06025-0001	Battery Holder	088-00789-0001
S'CL4050	120-06026-0001	Cathode Driver	120-00163-0000
Q112	007-00314-0000	Level Shifter	120-03074-0001
Q117	007-00329-0000	PIA 11016/1017	120-02018-0000
Q603	007-00319-0000	Display	037-00052-0002
Display Conn.	030-02300-0000	Light Bulbs	037-00032-0008
Inc/Dec Wheel	088-00766-0001	S-1007 Switch	031-00348-0001
CR604/605	007-06070-0000		

**PHASE LOCK LOOP IC CHANGES**

I-1103/1104 (120-06038-0002) 4046 IC's: If I-1103 has an orange dot, then change C-1107 to 108-05016-0020 cap p.c. .0033  $\mu$ f 50v. If I-1104 has an orange dot, then change C1114 to 108-05016-0098 cap .47 $\mu$ f 50V, R-1149 to 136-01503-0072 res. 150K ohm, R-1150 to 133-00096-0064 res. var. 500K ohm. If I-1103 or I-1104 have no marking or have a green dot, there is no change required. Original parts for:

- C-1107 is 111-00002-0008 cap. .0022uf 50V
- R-1150 is 133-00096-0037 res. Var. 200K ohm
- R-1149 is 136-01653-0072 res. 165K ohm
- C-1114 is 108-05013-0004 cap. .33 $\mu$ f 100V

**NOTES:**

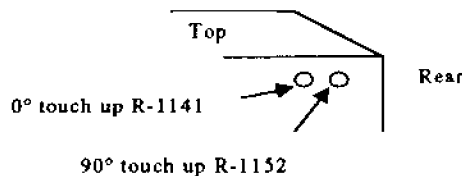

# The Technicians Notebook

By Jerry Gordon

# KR-85

Weight 4.0 lbs with rack and connectors. KI-225 weight 1.2 lbs.

Receiver sensitivity (ADF) 100 uv/m 6db s+ n/n. Bearing accuracy + -3 degrees.

Rev 1 Mar 1995

Indicator speed 7 seconds max for 175 degrees rotation. Audio output 50 mw into 600 ohms. Sense antenna 194 pf, effective height .25 meters. (see SM 75 revised). Must be aligned with the indicator that is to be used.

## SERVICE BULLETINS:

**KR-85-1** (Applicable up to sn 2264.) High Temperature Unlock of VCO. Kit KPN 050-01214-0000. Time required 1.0 hours.

**KR-85-2** Conversion of KI-225 to KI-225-01.

**KR-85-3** (Applicable to any sn.) To eliminate needle oscillation when KR-85 is channeled to a frequency one khz above the actual received frequency. Kit KPN 050-01282-0000. Time required 1.0 hours

**KR-85-4** (Applicable to sn 22999 and below.) To eliminate intermittent mis-channeling of KR-85 when channeling down in frequency. Kit KPN 050-01529-0000. Time required 1.0 hours.

**KR-85-5** (Applicable to sn 28426 and below.) The RF sense antenna amplifier will be damaged if subjected to high level RF from an HF transmitter.

## SERVICE AIDS:

**KR-85-101** Notification the KPN 007-00115-0000 (2N5037) is replaced by KPN 007-00330-0001.

## SERVICE MEMOS:

**SM 82** (Prior to sn 1775) Improper alignment of band switches.

**SM 92** States that all varactors are to be replaced as a set.

**SM 93** 1. When removing the PC board, lift the rear first and pull back due to the mounting slot and tab on the front of the board. 2. Check for loose set screws in the band change cam. 3. Use care in removing components from the PC board. 4. Early KR-85's did not have insulating material between the IF assembly and the chassis. Late units had insulating tape. 5. Frequency tapes on dial wheels on early units could come loose. Re-cement with Aron Alpha or Eastman 910 cement. 6. Yellow .1@12V disc caps open and cause intermittent operation. 7. Receiver noise sens. problems can be caused by noisy FET's. When replacing them use care. 8. Replace all 8 varactors as a set.

**SM 158** (Revised) Red epoxy capacitors by Erie (.1, .22, .02) @ 12Volt D.C. are unreliable. The green Centalab "Ultra-Kap" @ 16 volts D.C. are the replacements.

**SM 214** Procedure for testing KA42B sense amplifier. .5v/m field strength to KA42B input should yield 36 millivolts RMS + -3db output at 200 khz and 1700 khz.

**SM 228** (sn 1779 and above) R147 may need adjusting if ADF becomes erratic at low temperatures. Scope on collector of Q111. Frequency to 1699. Adjust for stable operation. Spray Q-109 with circuit cooler. If the oscillator becomes unstable, readjust R-147.

**SM 232** Replace all white hold downs with improved black ones. KPN 088-00125-0001

**SM245** ADF tuning problems

**SM299** 2N3646, KPN 007-00113-0000, Lead configuration change.

## KR-85 Common Part Numbers:

Band Switches: 031-00139-0000 & 031-00139-0001

Band Change Cam: 088-00175-0000

Connector For KA-42A: 033-00029-0001

Terminal Strip For KA-42A: 009-00003-0003



#### TIPS AND HINTS:

1. Check for a plastic cam that drives the band switches. If it is cracked, replace it with the new style brass one.
2. Check for the unit having the red caps as referenced in SM 158, .1 mfd. @12 volt capacitors. Replace them (28 each) with the 16 volt ones. Plan to spend two hours doing it.
3. If the homing is weak, replace the 3 ea, 1 mfd. tantalum capacitors in the loop amp stage along with the loop amp FET.
4. If there is any noise at all when you tap the band switches, replace them. They are expensive and take some time, but if you don't the radio will be back and the next time you will fix it for free. Cleaning will not last.

#### THE FOLLOWING IS COURTESY OF FRED REEVES, BENCH TECH FOR BENDIX/KING

The number 1 problem is band switches and caps. Some of the tantalum and electrolytic capacitors get old and dry out. Varactors appear to be replaced too often. If you suspect you have a varactor problem and you have a spare set or one from an old set, you can replace one at a time for trouble shooting purposes. (Of course if varactors are the problem, you know they must be replaced as a set.) To trouble shoot for a bad varactor, monitor the tuning voltage with a scope looking for spikes. Fred hasn't found any one particular varactor bad and when they fail they appear to be breaking down causing spikes in the tuning voltage. To check, lift the tuning voltage line where it feeds each varactor. This can be accomplished by lifting one leg of the varactor and look for a steady tuning voltage. If you had lost your VCO and it's not the varactor in the VCO that was bad, you will have your VCO frequency back.

Fred uses a little different trouble shooting method than in the book. Especially in the ADF section. The loop section seems to have the most problems. He usually monitors the collector of Q-108 in the loop amplifier in "ANT" mode to kill the servo oscillator. If you don't kill the servo oscillator all you will see is the oscillation. You will be able to see your peak to peak signal on Q-108. Vary your error and see the signal increase and decrease. This will tell you immediately if you have your signal there. 90% of the time the signal is not at this point. The problem is before Q-108. If you do have a good signal there, you can switch to ADF position and check the output of the modulation transformer, (the white wire), and expect 100 mv peak to peak. Monitor your increase and decrease of modulation by increasing and decreasing the error in the loop box. As you monitor the IF output, you should be able to see the IF modulate as you increase and decrease your error. This will tell you everything is good down to your servo amplifier. At TP-302, the first test point in the servo amplifier you should have a 50 mv sawtooth. To trouble shoot your servo amplifier using a dual trace scope, monitor the reference frequency from the servo oscillator, and the variable on the collector of Q-310. The signals should be almost identical but 90 degrees out of phase. At the collector of the last 2 darlington's, check for a sine wave signal. On the collector of Q-308 you should have a 200 mv peak to peak sine wave. The collector of Q-309 should have a 4 volt sine wave. (not a true sine wave.) If you don't have either of these signals there are a couple of frequency by-pass caps (depending upon which signal is missing), that may be open. (yellow .1mfd C-318, C-319, C321, C-322). There is also an adjustment to peak the variable signal coming in. If you can't get any reaction while adjusting this pot, this is a good reason for checking these particular caps. Monitor the IF and turn the signal all the way down. If you have more than 25 mv of noise on the IF line, check C-238 (47 mfd) for leakage or being open. This cap can generate noise in the IF and kill the sensitivity. If the signal generator output is too high, it will not show up. Also check for noisy FET's in the loop stage and Q-101.

#### NOTES:

# The Technicians Notebook

By Jerry Gordon

# KR-86

Revision No: 1 June 1995

Weight: 3.1 lbs unit only, 3.9 with rack and connectors.

KA-42B weight 2.4 lbs.

Receiver sens: 100 uv/m for 6 db s+ n/n ADF mode, ANT mode 70 uv/m.

Bearing accuracy + -3 degrees from 70 uv/m to .5v/m.

Needle speed: 6 seconds for 175 degree off bearing homing and 70 uv/m signal.

Audio: 50 mw @ 500 ohms. Sense and effective height .25 m. Sensitivity 9 db s+ n/n for 70 uv/m field strength.

## • SERVICE BULLETINS:

**KR-86-1** (Applicable to SN 12516 and below) To prevent damage to RF sense amplifier from strong radiated RF levels from HF transmitter. Modification consists of adding two diodes to the sense antenna input of the KR 86. Time required 1.0 hours, including testing.

**KR 86-2** (Applicable to SN 17913 and below) To eliminate audio and pointing interference when tuned to 280 khz. Modification consists of adding a resistor and a capacitor between the detector and the audio amplifier to eliminate the 140 khz IF frequency which is still left after detection. Parts required, 1 ea. 113- 06103-0000, 130-00472-0023, 050-01734-0003. Time required 1.5 hours.

## • SERVICE AIDS:

**SA KR 86-101** Improved loop gain. Change Q 201 (MPS H04) KPN 007- 00226-0000 to (SPS 8286) KPN 007-00226-0002. Directly inter changeable.

**SA KR 86-102** (Applicable to SN 25551 and below) Part required KPN 076-02833-0001. Improved type Cam switch to all metal.

**SA KR 86-103** (Applicable to ADF's beginning with SN 7978) Volume control pot changed from 1K to 10K (adding a 1.1K resistor in parallel). Reduces the audio output of the radio when the volume control is set to its minimum setting. To replace a 1K pot order 1 each of the following: KPN 133-00269-0001. and KPN 131-00112- 023. Check the Service aid for instructions.

## • SERVICE MEMOS:

**SM 75** A long drawn out procedure to determine the proper ADF sense antenna configuration. What it boils down to is you need a capacitance meter in your shop.

**SM 158** Red "Erie" capacitors in unit. .1, .05, .22, .02, mfd @12 Volt are bad units and should be replaced with newer caps.

**SM 214** KA 42B sense signal output test procedure. This shows how to check the sense amplifier in the KA 42B. It will not check the loop portion.

**SM 245** KR 86 ADF tuning problems. High band VCO tuning. Check T 210, KPN 019-03052-0002. The transformers with "HK" printed on the side have more capacitance than others. If T 210 is changed and the "HK" type is used, it may be necessary to change C 241, a 10 pf mica to a 5 pf mica, KPN 104-00001-0042, to allow the unit to meet high band VCO specs.

The following is courtesy of Bendix/King product support

• **COMMON PROBLEMS INCURRED AT MANUFACTURER REPAIR LEVEL.**

1. When a 1 khz tone is present throughout unit, replace C308 or C307.
2. When audio is present with volume turned down, replace volume control. (See Service Aid SA KR 86-103)
3. When VCO is out of tolerance at 1750 (+ /- 400 hz), replace Y301.
4. If any variable cap will not peak, even with the screw removed, replace associated transformer.
5. If the high end of all bands can't be peaked, replace .1 uf caps near varactors.
6. If AGC voltage stays too high, replace C284.
7. If the low end of bands won't tune sharp enough, replace L206-L208.
8. The voltage across the motor when slewing should be approximately 4 vdc.
9. If BFO output is low, make sure C306 is a .22 uf.
10. If you have good audio, but weak pointing, check for approximate 150 mv pp at pin 4 of I201 with 1.5 v from signal generator.
11. If the needle is consistently off all around the card, remove the face plate, secure the lens, tighten the needle to the shaft and position the needle correctly.
12. Brass cams are now available to replace the old plastic ones under the same PN 076-02833-0001.
13. 1 1/2 volts signal input should give 1.7 volts on AGC line and base of Q-202 should be 15 mv.

**PART NUMBERS:**

Matching assy for KA-42B	200-02104-0000
KA-42B	071-01133-0000
Molex pins	030-1046-XX (XX = Number of pins)
Molex pin remover: Molex No HT-1884,	047-05099-0002
28 Volt Rack/Cable plate sub-assy	200-00523-0001
Mounting rack:	047-02510-0001
Band switch:	031-00178-0000
Connector for KA-42A	033-00029-0001
Terminal Strip for KA-42A	009-00003-0003

**NOTES:**

A3CR101	353-3264-020	922-6131-020
A6Q2	352-5016-010	352-1045-030
A6CR1/3/5/7	353-3264-020	922-6131-020
A6L1/2/4/5	628-5448-002	278-0415-020

### COMMON PROBLEMS AND FIXES COURTESY OF S-TEC CUSTOMER SERVICE

I. + 5, -12VDC power supply common problems: No + 5VDC or -12VDC. Usually can be repaired by replacing A2U1. No -12VDC only. Usually A2CR2.

II. Noisy audio common problems: Synthesizer VCO frequency drifting. If tuning voltage is correct, the problem usually lies with A3L1 (39mh coil).

III. Nervous VOR needle common problems: (A) Detector signal oscillating. Realign receiver for maximum AGC according to alignment procedures in manual. Then at 47 DBM, set R39 to 1.4VDC on the case of Q3. Set R29 detector for .5VRMS. Repeat AGC delay (R39) and detector level adjustment (R29) until results are met. Then connect oscilloscope to A6TP3 and observe detector signal. Adjust C23 until detector signal just stops oscillating. Go back and verify 4.5VDC AGC voltage at 97.5 DBM on gen.

(B) A.C. ripple on 10VDC line at junction of A6R108 and A6R113. While looking at junction with oscilloscope, verify AC ripple increases and decreases while adjusting volume knob. Fix: Usually A6C109 and/or A6R113 bad. (C) If not step (B) above, check A.C. ripple at A4VR1 and A4VR2 on VOR converter board. Ripple here usually means VR1 and VR2 have been changed and the impedance of the new zeners are causing this A.C. ripple.

IV. VOR needle will not adjust to center. Common problem: Needle shifts left or right of center and will not stay centered. Check 70 u sec. neg. going pulse width at TP2, ensure it does not self-oscillate when R22 is adjusted to both ends of its range. Fix: If 70 u sec. neg. going pulse width self-oscillates, replace A4U2. If 70 u sec. neg. going pulse width is good, replace chopper A4Q1.

V. NAV channeling. The VIR-351 switching unit utilizes BCD and 2x5 control logic. The 2x5 runs straight from the switches to the rear connector. The nav unit uses BCD information for itself. The BCD logic runs straight to the rear connector and from the rear connector to A5 LOC/PWR sup board, from the A5 board through A5-U4, then off the board to the front display (A1 board). Common problem: NAV1 channels TCR-451 and NAV2 channels some frequencies but not all. NAV1 seems to effect NAV2 2x5 channeling or vice-versa. Fix: Once you verify DME NAV select lines and aircraft wiring are correct, then you probably have a bad isolation diode in the NAV unit itself on the 2x5 switches. (Note: You cannot have a BCD external short problem without seeing it on the NAV display.)

NOTES:

# The Technicians Notebook

By Jerry Gordon

# KR-87 ADF

Weight: 2.9 lbs (3.2 lbs. w/rack & conn.)

KI-227: .7 (w/conn) KI-228: .91 (w/conn.) KA-44: 2.0 lbs. KA-44B: 2.8 lbs.

Revision No: 2 10/97

Power requirements 11-33 volts, 12 watts

Sensitivity: (ADF) 150 uv/m = 6db s+n/n (ANT) 70 uv/m = 6db s+n/n Part Numbers: Display 037-00055-0000

Ind. Accuracy 3 degrees, Speed 7 seconds for 175 degree spin.

KHZ Knob: 088-01057-0001

Audio output 50 mw across 500 ohms.

"C" Clip for KHZ shaft: 090-00036-0004

## SERVICE BULLETINS

**KR87-1** Allows the reset and reset lines to be tied to +28V or 14V.

**KR87-2** Adds "Use" and "Stby Timer" to front panel display lens.

**KR87-3** Flight timer with remote switch operation.

**KR87-4** (Applicable to SN 13238 and under.) Eliminates reset problems of the flight timer dual installations. This problem occurs when both units are connected to the same switch. When power is removed from one of the units, it will hold the line low and cause a reset. This modification consists of adding two diodes to the unit. Part number 007-06016-0000. Time required 1.0 hours.

**KR87-5** (Applicable to SN 17199 and below.) Intermittent operation of KR87 when it is subject to vibration. Readjust T122 and secure the core with a different type of loctite. Customer option, no warranty. Time required 1.0 hours including testing. Part number for loctite 016-01007-0001.

**KR87-6** Adds capability to drive two KI227 ADF indicators.

**KR87-7** (Applicable to SN 39227 and below.) Prevents oscillation on the sine and cosine outputs when the KR87 is used with a high impedance load such as the KI 229 RMI. Consists of removing two capacitors, C515 and C520, from the main board. Time required 1.0 hours, including test and alignment.

**KR87-M1** Converts a KR87, p/n 066-01072-0000

to an 066-01072-0004, or a KR87, p/n 066-01072-0002 to a 066-01072-0005.

007-00373-0000

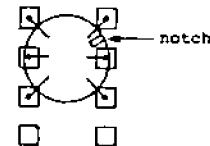

007-0427-02

007-0423-01

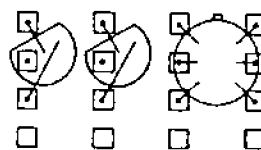

Lead Configuration for  
Old Artwork Boards  
(Revision 12 or below)

007-0427-02

007-0423-01

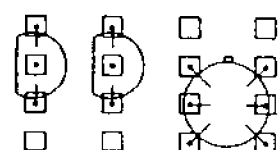

Lead Configuration for  
New Artwork Boards  
(Revision 13 and above)

## SERVICE AIDS

**KR87-101** Discontinuance of transistor, KPN 007-00373-0000. Dual FET used in the KR87 as the first mixer had been discontinued by the vendor. The KPN 007-00373-0000 is no longer available and will have to be replaced with either KPN 007-00427-0002 or KPN 007-00423-0001. The KPN 007-00427-0002 is what is currently being used for replacement and are a matched pair of 007-00427-0001 transistors and should be installed according to figure below.

**KR87-102** Increased bearing needle speed. Decreases the value of the damping capacitors, C562, C563, C564 and C565 from 22ufd, KPN 096-01090-0000, to 6.8ufd, KPN 096-01053-0000.

**KR87-103** Change of S506 to a new style switch. (Applicable to SN 12112 and above.) The old style switch was mounted on the main board and would break when excessive pressure was applied to the selector knob. The new style switch is removed from the board and mounted on a bracket. This bracket and switch assembly is

available under KPN 250-00087-0000. If the old style switch breaks, replace it with this kit. Bus wire and teflon tubing for this is available under KPN 050-01783-0000. See following drawing.

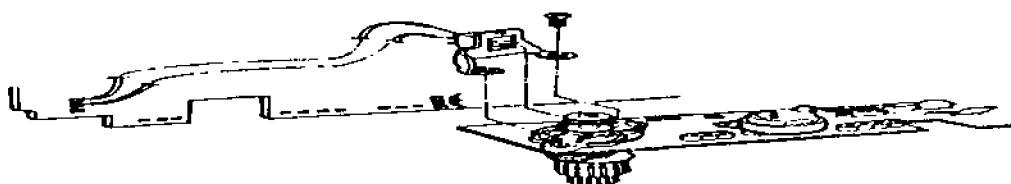

**KR87-104** Change of I402, the display driver, to an improved type. The new driver is a UDS6118A-1, KPN 120-00161-0000, and does not require the pull up resistor module. If a KPN 120-00161-0000 is used to replace a KPN 120-04083-0000, the resistor module should be removed.

**KR87-105** (Applicable to SN 12978 and above.) Improved regulation of the 6.2 volt line in the KR87. Change consists of changing the value of R329 from a 10K ohm, EW, 5% resistor to an 8.2K ohm, EW, 5% resistor, KPN 131-00822-0013.

**KR87-106** (Applicable to SN 13499 and below.) Eliminates the loss of the last used frequencies stored in memory during momentary power loss conditions. Consists of changing I506 the microprocessor, KPN 120-02038-0001, to a new style microprocessor, KPN 120-02038-0002.

**KR87-107** Discontinuance of F.E.T. SD306DE, KPN 007-00317-0001. No longer available. Replaced by FET MFE 521, KPN 007-00310-0000. It is a direct replacement.

**KR87-108** Replacement of obsolete F.E.T. SD306DE, KPN007-0317-00, used as 2nd RF Mixer, Q104, on the receiver board. Replaced by FET 3N212, KPN 007-00452-0000. Parts kit is available, KPN 050-26636-0000. Replace Q104 with 3N212, KPN 007-00452-0000. Replace R120 with 15K ohm resistor, KPN 131-00153-1013. Replace R121 with 3K ohm resistor, KPN 131-00302-0013. Remove C221.

**KR87-109** Display brightness. If a King display is replaced with a Dale display or vice versa, the photocell dimming adjustment, R571, will have to be readjusted for the pulse width at TP506 that is appropriate for the particular display that is being installed in the unit. Both displays have the same part number, KPN 037-00055-0000. The Dale display has the word "Dale" printed on the back side of the display. The King has no printing on it.

**KR87-110** Removal of IC sockets. Some problems have been traced to intermittent connections between the IC chips and their sockets. Therefore the IC sockets for I-506 and I-104 have been eliminated in the production of new units. If intermittent problems are suspected, the IC's may be unplugged, the sockets removed, and the IC's soldered directly to the board.

**KR87-111** Replacement of DS-501 through DS-505 light bulbs, PN 037-00075-0000. To balance the lighting with the rest of the Silver Crown line, these bulbs have been changed to PN 037-00012-0001. If it is necessary to change one of the bulbs, they should be changed as a set to assure lighting balance.

#### **KR87 QUIRKS AND CHARACTERISTICS - COURTESY ALLIED SIGNAL PRODUCT SUPPORT**

1. Bad pointing and intermittent lock up-align the coherent detector.

**A.** Other signals of a bad coherent detector are the lack of 8V at pins 1 and 7 of I108, and the lack of 140Khz at TP104.

**B.** Also an intermittent coherent detector is detected by an untriggerable signal at I114 pin 3. (Looks like boxes instead of pulses). Replace T123 or I111 and I112.

2. If a unit has a low AGC voltage at R589 or an unadjustable voltage at TP 108, or just plain bad sensitivity. Replace Q103 and 104.

3. If you have audio, but no pointing. Check your 32 Hz BPF. Chances are that you are not getting your 32 Hz pointing info. (Also when this happens make sure you have a good KTS-156 test set and module, and that they are set up properly.)
4. When your display reads all 8's, check R411 on the display board, it's probably bad and needs replacing.
5. If when you turn on your unit the display lights up "ANT 1" real bright, replace R401.
6. If you find I401 bad, always replace I402 along with it and vice versa.
7. Always clean the display connections and tighten them by pushing the pins back with a standard screwdriver.
8. If certain letters do not illuminate on the display, check the blue note box on the display schematic. It tells you what the bus lines are that control which letters, then follow those bus lines to the main board and replace the respective diode that is the pull-up on that line. If that doesn't work then replace the display driver I508 or I507 on the main board.
9. When your indicator does not point to 90 or 270 even in ANT mode, replace Q503 and Q508, after checking for your -6.2 V at pin 4 of I502. If its OV then it is either Q503, Q504 or a shorted C545.
10. If when you turn your unit off, and then back on and you lose your frequency that was last displayed, and 800 appears on the display, check your -26V, if you have that then replace I513. If you don't have -26V, replace CR308 on the power supply.
11. Display won't light & unit drawing <400 ma. check CR-305 & CR-307.
12. Push buttons and shafts have changed size. When ordering, call factory service and get new numbers.
13. If pointer goes to 45 degrees or will not park at 90 degrees. Look at LH corner on main board under caps for burnt R-587 or R-588.
14. Display with intermittent segments. Remove display and clean contacts with eraser. Retention display mountings.
15. Unit will not point or lacks sensitivity when using KTS-156 test set, which was not the original complaint. Clean the switches on the KTS-156.

**NOTES:**

# The Technician's Notebook

By Jerry Gordon

# KT-76C

Revision 0, July 1999

Weight: 2.0 Unit only, 2.4 Including mounting rack.  
Transmitter power: 125 watts peak minimum, 500 watts peak maximum.  
Receiver sensitivity: -73dbm +- 4dbm  
Altitude: 35,000 feet  
Input voltage: 11 - 33 VDC

## SERVICE BULLETINS:

**KT 76C-1** Applicable to P/N 066-01156-0101 S/N 3999 and below. Do not incorporate these changes. This bulletin has been superseded by SB KT 76C-2.

**KT 76C-2** Applicable to P/N 066-01156-0101 S/N 4169 and below. Corrects reply rate limiting. Supersedes KT 76C-1. Replaced U-1 on main board. Parts required: 1 ea. 122-30129-0004. Time required: Two hours.

**KT 76C-3** Applicable to P/N 066-01156-0101 S/N 6599 and below. Isolates the transmitter from the external load to prevent the antenna and coax from pulling the transmitter off frequency. It consists of removing the existing coax cables and installing circulator board in the final assembly. Parts required: .3 inch of 016-01124-0001 double sided tape, 2 ea. 089-05899-0003 2X56X3/16 screws, 1 ea. 057-05937-0001 drill template, 1 ea. 155-02863-0002 cable assembly, and 1 ea. 200-09478-0000 circulator board. Time required: Two and one half hours. See the bulletin for specific details of the procedure.

**KT 76C-4** Applicable to P/N 066-01156-0101 S/N 6599 and below. Consists of bypassing a circuit trace with a jumper to prevent the 1300 volt line from shorting internally. Most units S/N 3181 to 6599 will have the jumper, but will not indicate that mod 4 was done. Two holes will have to be drilled in the main board to isolate the 1300 volt circuit trace. Then you use high voltage wire to jumper around the isolated trace. If there is a jumper between J4 and CR7, mark the unit as having mod 4 done. If not, drill a .12 inch hole in the circuit board at the two places indicated in figure two. Reconnect CR7 and J4 with high voltage wire (P/N 025-00234-0000). Route as shown in figure one. Seal with DC RTV 3145 (P/N 0116-01082-0000)

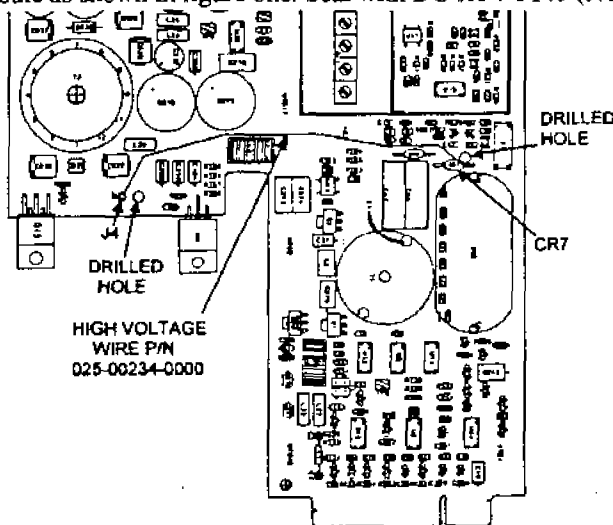

Figure 1  
KT 76C Main Board  
300-09093-0020 Rev 3

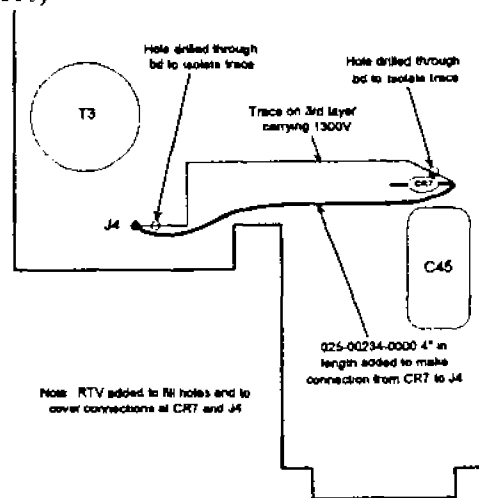

Figure 2  
KT 76C Main Board  
Drilling Detail

## SERVICE AIDS:

**SA KT76C-101** (Applicable to SN 3599 and below) Improvements over the sensitivity range of the receiver and improved isolation between the transmitter and the external load. These changes must be incorporated in conjunction with mod 2. Consists of replacing 2 cable assemblies and adding 2 resistors. See the service aid for complete instructions.

**Note:** There will be a new main board incorporated in a production change starting with SN8200. This board will give increased receiver sensitivity over the operating temperature range. This board will be identified as -0060 .



# The Technician's Notebook

By Jerry Gordon

# KT-79

**KT-79:** Weight 3.4 Lb.

**Transmitter Power:** 200 Peak Watts Min.

**Receiver Sensitivity:** -74 dbm Nominal

**Input Power:** 11-33 Volts, 10 Watts Typical, 25 Watts Max.

Rev. 2, Dec. 1999

## SERVICE BULLETINS:

**KT 79-1** (Applicable to: Serial number 1679 and above, stamped Mod 1 with six correct lamps and two correct buttons. Serial number 1483 through 1678, stamped Mod 1 with six incorrect lamps and two incorrect buttons. Serial number 1321 through 1482, not stamped Mod 1 with six incorrect lamps and two incorrect buttons. Serial number 1320 and below, not stamped Mod 1 with six correct lamps and two incorrect buttons.) The KT 79 lighting was not consistent when panel lighting was varied from 11 to 33 volts. Brightness tracking was not good at low voltages. Serial number 1321 through 1678 used a brighter lamp but the six original lamps were satisfactory when the new molded buttons were used. Parts required: Kit 050-02146-0000 to replace six lamps in serial numbers 1321 through 1678 and two buttons to be replaced in serial numbers 1678 or below. Time required, 1.0 hour, warranty reimbursable on serial number 1678 and below.

**KT 79-2** (Applicable to sn 2194 and below) To prevent the display from blanking because C-1 72 shorts, loading down the power supply. Parts required, 105-00018-0074 (Mylar Cap .047 @200V). Time required, 1.0 hours, warranty reimbursable.

**KT 79-3** (Applicable to sn 4523 and below) Units with sn between 4434 and 4523 will be marked Mod 3 but will not be in compliance. To correct memory loss of the VFR preset code when power was cycled. Problem apparent in Piper Malibu aircraft. Add one diode and cut two circuit paths. Kit required: 050-02775-0000. Time required 2.0 hours.

**KT 79-4** (Applicable to sn 7299 and below) Replacing the transmitter board with an improved design. If transmitter 200-06460-0000 fails, replace with 200-08650-0000/0001. Units above this sn have the new improved board installed during manufacture. Time required: 1.5 hours.

## SERVICE AIDS:

**SA KT 79-101** (Applicable to sn 1500 and below) Replaced Revision 3 and below display boards with Revision 4 board. Check this service aid whenever it is necessary to replace an anode or cathode driver IC. Some part numbers have been changed depending on the display board revision level.

**SA KT 79-102** Product Improvements:

<u>Approx.</u>	<u>S/N Board/ KPN</u>	<u>Reason</u>	<u>Description of Change</u>
1. 1575	Main/200-6461-00	To maintain 90% replies When P1-P2 pulse spacing varies greater than 2.6 microseconds at -72dBm	1180 to 120-8029-01 transponder LSI
2. 1602	P Supply/200/6456-00	Increase drive to 0203	R219 to 131-0680-13 68 ohm EW5% resistor
3. 1763	Main/200-6461 -00	Change all IC sockets for improved reliability	16 contact socket to 033-0092-11 (1 ea.) 18 contact socket to 033-0092-12 (2 ea.) 40 contact socket to 033-0092-00 (1 ea.)

<u>Approx. S/N</u>	<u>Board/KPN</u>	<u>Reason</u>	<u>Description of Change</u>
	Proc/200-6458-00	Change IC socket for improved reliability	40 contact socket to 033-0092-17 (1 ea.)
4. 3773	Main/200-6461 -00/01	Replacing Q1 09 with a faster turnoff transistor to increase the unit MTL dynamic range and side lobe suppression	0109 to 007-0113-00 2N3646 NPN transistor
5. 3789	Mod/200-6459-00/01	Turn-off power oscillator between TX pulses	CR506 & CR 507 to 007-6106-00 1 N4156 diodes
6. 3802	Mod/200/6459/00/01	to improve spectrum by slowing down the rise and fall time of the modulator	C506 to 111-2223-51 22 KPF 100V, R518 and R519 to 131-0027-33, 2.7 ohm, HW 5%

## Page 2 KT-79 Technician's Notebook

**SA KT 79-103** Diode CR141 (007-06016-0003) is no longer available. When it is replaced by 007-06046-0005 (1N916A), replace R197 with a 270 ohm EW, 5% resistor (131-00271-0013) and align oscillator.

**SA KT 79-104** None issued.

**SA KT 79-105** Replacement of S-101 (030-00370-0000) on the main board. If replacement is needed, use Kit 050-03498-0000. It is a different switch, so you will need the Service Aid to see the procedure for replacement.

**SA KT 79-106** Cable replacement kit (050-02814-0043) which was used to replace the main board to modulator board cable is now obsolete. It is replaced with with jumper cable 155-02031-0007.

**SA KT 79-107** Replacement of obsolete microprocessor 120-02084-0000. The replacement for the part is 122-30171-0001. This replacement is a factory replacement only. If the microprocessor appears bad, return the unit to the factory for diagnosis and repair.

### SERVICE MEMOS:

**SM KT 79-298** (Revised 6/13/84) Suppression pulse characteristics for King DME's and transponders. If you have any questions regarding suppression hookup, consult this service memo.

**SM KT 79-336** Lists KT 79's manufactured prior to January 1, 1990. KPN 066-01053-0000 sn 6164 and below were manufactured prior to the above date.

### SYSTEM ALIGNMENT:

- a. Adjust the system delay by observing the interrogation pulses on one scope trace and the detected video from the test set on the other trace.
- b. Adjust R144 to set the delay from the leading edge of the last interrogation pulse to the first reply pulse to 3.0 microseconds.
- c. To adjust the minimum threshold level (MTL), set the transponder test set RF level to -72 dBm.
- d. Adjust R128 for 90 to 95% reply efficiency.
- e. Set the reply rate limiter R1 35 by placing the code 0000 on the KT 79 and the test set to -60dBm signal level with an interrogation rate between 1500 and 1800 PPS.
- f. Adjust R1 35 for a transponder reply rate of 1200 PPS.

### DIMMING ADJUST:

- a. To set the minimum brightness level adjustment R327, monitor TP307 on the processor board.
- b. Cover the bezel and lens of the KT 79 so that no light reaches the photocell.
- c. Adjust R327 for a 90 microsecond pulse width. R327 will have no effect on the maximum brightness. R327 may also be adjusted to match the dim brightness level of the other units in a given aircraft panel.

### NOTES:

# The Technician's Notebook

By Jerry Gordon

# KX-125

Revision No: 0 4/1997

Weight 4.36 lbs. 760 channels, transmitter 5 W min. Freq tolerance within .002%.

Com receiver 2 uv 6 db s+s/n. AGC 5 uv-20,000 +- 3db.

Nav receiver 2 uv or less for full flag. AGC less than 1 degree change with 10 uv - 20,000 std. omni signal.

VOR accuracy +- 3 degrees. 5-1k dev loads, 3-1k flag loads, 3 200 ohm to-from loads.

Phone output 100 mw @ 500 ohms, 4 ohm output 8 watts min.

---

## SERVICE BULLETINS:

**KX-125-1** Replacement of R1114 with CR-148

## SERVICE AIDS:

**KX-125-101** Replacement of gray bezel with black bezel. If you need to replace the gray bezel the part number is 088-01385-0002

**KX-125-102** Improved operation with Doppler VOR. R-274 on the Nav board changed to 39.2K resistor (139-03922-0000). A 26.7K resistor (136-02672-0072) added between C-655 and the junction of C-654 & TP-510.

## INSTALLATION BULLETINS:

#335 Compatibility problems with KA-120

## THE FOLLOWING COURTESY OF ALLIED SIGNAL TECHNICAL SERVICE:

The KX-125 originally was a Silver Crown unit. The face plate and part number were changed making it a member of the Crown line. You can not replace the new face plate with one of the original metal ones due to some hardware changes. You may, however replace the plastic one with another color. See service aid above.

The original units used a linear taper pot for the com volume control. This would lend itself to an inability to set the volume to a desirable level. It could be either too high or too low. The customer might complain about selecting a correct listening level. The pot was changed to an audio taper during production in March 1993. If you should find a KX-125 with the above symptom, check the volume control. If it is one of the old linear taper styles, replace it with the new version. The part number (133-00561-0000) has not changed, You will get the audio taper pot.

The Nav volume pot was changed in March 1992. It was changed from 133-00561-0001 (15K) to 133-00561-0002 (25K). The change reduced the minimum nav audio.

The mike key will operate with 3vdc. The transmit time-out for a stuck mike cannot be disabled. It is set at the factory for 35 seconds. Units can be reset in the field for 35 to 120 seconds. Upon recycle of power you can begin another 35 seconds of transmission.

If you experience problems with segments out in the display, you may find the zebra strip giving you the problem. If you tighten down the screws to tight, it distorts the zebra strip and may cause a segment to be missing. You have to loosen the screws, and adjust the strip to get all your segments operational. Then carefully tighten the screws, but not to the point it distorts the strip. Alignment of the zebra strips can be rather tedious and time consuming.

It has been noticed that I-107 is causing some audio distortion. Replace it if this symptom appears.

## ADJUSTMENTS:

**Voltage regulator:** Volume control mid range, adjust R-189 for 9.0 v at TP-103

**Comm VCO:** Within 60 seconds after turn on, adjust C-134 for 148.375 mhz at E-143 with freq selector at 136.975mhz.

**Transmitter adjustment:** Adjust R-256 to obtain minimum of 5 watts across band. Adjust C-418 for minimum variation.

**Modulator adjustment:** Set R-1009 to mid-range, R-267 max CW. At 128.50 mhz, apply .4 vrms @1khz to mike input. Adjust R-1009 for 85% modulation. Adjust R-267 for 70% modulation.

**Sidetone adjustment:** With same mike input as above, adjust R-221 for 4 mw (1.4 vrms) into 500 ohm load.

**Comm receiver:**

**Noise squelch.** With signal input of 2.0 uv (hard) modulated 30% with 1khz tone, adjust R-176 to just break squelch.

**Carrier squelch.** With 128.5 mhz signal, 12.5 uv (hard) modulated 85% with 8khz tone, adjust R-184 to just break squelch.

**Climax filter:** With 128.5 mhz signal, 100uv (hard) modulated 85% with 4.5 khz tone, disable the squelch, monitor the comm audio, and adjust L-110 for minimum audio output.

**Nav receiver:**

**Voltage regulator:** Adjust R-613 for 9 vdc at TP-506

**Nav VCO:** Within 60 seconds after turn on, adjust C-706 to 96.55 mhz with freq sel set at 117.95 mhz. Adjust T-510 for 5.25 vdc at TP-505. (must be greater than 2.25 vdc).

**AGC adjustments:** With 100 uv (hard) signal input, adjust R-513 for 0 vdc at TP-501.

**VOR PLL adjustments:** With 112.6 mhz signal, 1000 uv (hard) signal, unmodulated, adjust R-664 for 9960 hz at TP-509. With standard VOR signal applied, adjust R-657 for max at TP-510. Adjust R-664 for 4.0 vdc at TP-508

**VOR & LOC centering:**

With 110.05 mhz, standard VOR signal at 1000 uv (hard), bearing generator at 0 from and OBS at 0, allow 10 seconds to lock on, and connect jumper between TP-802 & TP-803. Momentarily ground TP-801 and verify centering.

With 110.1 mhz, standard LOC signal predominate 90 hz @ +.093 ddm, allow 10 seconds to lock on, momentarily ground TP-801 and verify 3 markers to the right. Set generator to 150 hz predominate, allow 10 seconds to lock on, momentarily ground TP-801 and verify 3 markers to the left. Remove jumper between TP-802 & TP-803.

**Auto-Pilot CDI:**

With 110.05 mhz, standard VOR at 0 degrees signal at 1000 uv (hard), adj OBS to 0 degrees. Adjust R-1095 for 0 vdc on auto-pilot output. Set radial on generator to 10 degrees from. Adjust R-1090 for +150 mv at auto-pilot output. Repeat both adjustments as necessary.

**VOR flag level:**

With 112.5 mhz, standard VOR (center) signal at 2 uv (hard). Reduce input until auto-pilot output fluctuations are greater than 7.5 mv. Ground TP-802 and then ground TO-801. Remove both grounds. The Nav flag on the unit should be on.

**NOTES:**

## The Technicians Notebook

By Jerry Gordon

# KX-145

Revision No: 1 6/1994

Weight 3.1 lbs. including rack. KI205 .7 lbs.

720 channels. Transmitter 2 watts @.75% modulation. Sidetone 10 mw @600 ohms.

Comm Receiver 1.5 uv (soft) for 6db. AGC 12.5 -10,000 uv (soft) + -3db.

Nav Receiver 1.5 uv (soft) for 1/2 flag. AGC 25 - 10,000 (soft) + -3db. Accuracy + -1.5 degree nominal. 3 degree max.

Phone output 10mv @500 ohms. Speaker output 3 watts.

### SERVICE BULLETINS:

**KX145-1** All serial numbers. Motor boating below 11.5 volts. Kit 050-01642-0000 Time required .5 hours.

**K145-2** (Applicable to S.N. 3080 & below) To reduce FM interference caused by overloading RF amplifier. Kit 050-1572- 0000 Time required 2 hours.

**KX145-3** (Applicable to S.N. 3080 & below) Increase audio output on Nav channels. Kit 050-01573-0000 Time required 1 hour.

**KX145-4** Rvised 11/8/76 (Applicable to S.N. 3550 & Below) DC ground in transmitter RF output to eliminate sympathetic re-radiation from 2nd. VHF comm transmitter. Kit 050- 01589-0000 Time required 1.25 hours.

**KX145-5** (Applicable to S.N. 4537 & below) Low temperature operation in localizes. Kit 050-01640-0000 Time required 1.5 hours.

**KX145-6** revised 10/15/78 (Applicable to S.N. 5365 & Below) For transmitter distortion caused by FM modulating of comm SMO. Kit 050-01688-0000 Time required 3 hours. KX145-8 should also be done at this time.

**KX145-7** None assigned this number.

**KX145-8** Revised 9/1/79 (Applicable to S.N. 6686 & below) Transmitter garbling due to FM of VCO. Kit 050-01798-0000 Time required 2.5 hours.

**KX145-9** (Applicable to S.N. 7920 & below) SB KX145-6 (rev 1) and KX145-8 (rev 1) must be done first. Transmitter garbling problems. See bulletin for parts list. Time required 2.5 hours.

**KX145-10** (Applicable to S.N. 8401 & below) SB KX145-6 (rev 1), KX145-8 (rev 1), and KX145-9 Must be done first. Parts required-1 each KPN 019-02082-0004 (.33uh choke. 10%) Time required 2 hours.

### SERVICE MEMOS:

**SM 254** KX145 mixer diodes (Applicable to S.N. 2700-4299) CR404- CR411 (KPN 007-06067-0000) When replacing, replace as a set of 8. The above part number is for a set of 8.

**SM 299** Transistor 2N3646 (KPN 007-00113-0000) Lead configuration change.

### The following is courtesy of Bendix/King customer support.

Receiver problems: Weak receiver caused by insufficient gain in the IF strip. The IF AGC voltage should be above 3.8 volts at the AGC test point. Many times technicians change the IC to repair the weak symptom. Many times the problem is the mixer diodes. Intermittent pots are a problem. Look for black ones labeled "Bourns" and replace them with the new style. Transmitter problems can just about be eliminated by performing the above mods. (Mod 4, Mod 6, Mod 8, Mod 9, and Mod 10). The estimated time for these mods is a total of 11.25 hours on a pre Mod 4 unit. You should be able to do them in less time if they

are done all at once. Do not parallel the speaker audio output with another radio as damage to the output transistors can result.

VOR problems: Watch for intermittents in the "Bourns" pots as mentioned above. Also look for intermittent orange coupling caps. If you look in the parts listing for the orange caps, you will be referred to a different part number. Sometimes a VOR problem arises where you are unable to read the required .26 volts RMS on TP 306. If it reads low, it may be difficult to determine if the 30 hz variable filter is bad at that point or if the level coming from the receiver may be low. Coming out of the detector at TP 404, you should have .5 volts RMS. If you do not have the .5 volts, you may have bad mixer diodes or detector transistors. The filter cap C-437 can open or may not be switched to ground. If either happens you may not get your .26 volts at TP 306. The "finger pots" are no longer available. The replacement part numbers are in the manual.

Trouble shooting the receiver with a low frequency generator while using the signal to noise output for your indication can be helpful. 20 to 40 micro volts injected in TP 402 should give a decent signal to noise ratio. The injection at TP 403 should be 50 to 100 micro volts. The AGC has to be above 3.8 volts to be working. The transmitter drive from Q505 collector should be 4 to 8 volts peak to peak. You should see amplification down the line.

SMO BOARD: By grounding TP 205 or TP 206 alternately you can check the operation of the charge pump. Grounding one will send the tuning voltage to the supply level and grounding the other will send the tuning voltage low. This will tell you if the charge pump is working. Set the VCO at a certain frequency and channel the radio above and below this frequency. Watch the 25 khz wave form on TP 203 to see if it changes. If this happens the problem is in the phase/frequency comparator region. To check if I 204 is bad check both inputs. If they are both low, you will get a divide by 11. If either one is low, you will get a divide by 10. Look for this output I on pin 3 of I 205. If the points are high, you won't divide at all. If it shifts one mho across the band then I 208 is bad.

Audio inhibit circuits kill the COMM audio when the frequency selector reads 116 or 117 MHZ. When the inhibit chip opens or you have an open on that line, you will have no receiver audio.

Checking the mixer diodes can be accomplished by measuring the signal on both sides, looking for an appreciable signal loss.

Part number for the face plate with the switch board is 200-01542-0000. The number without the switch board is 200-01542-0001. The switch board only is 200-01618-0000.

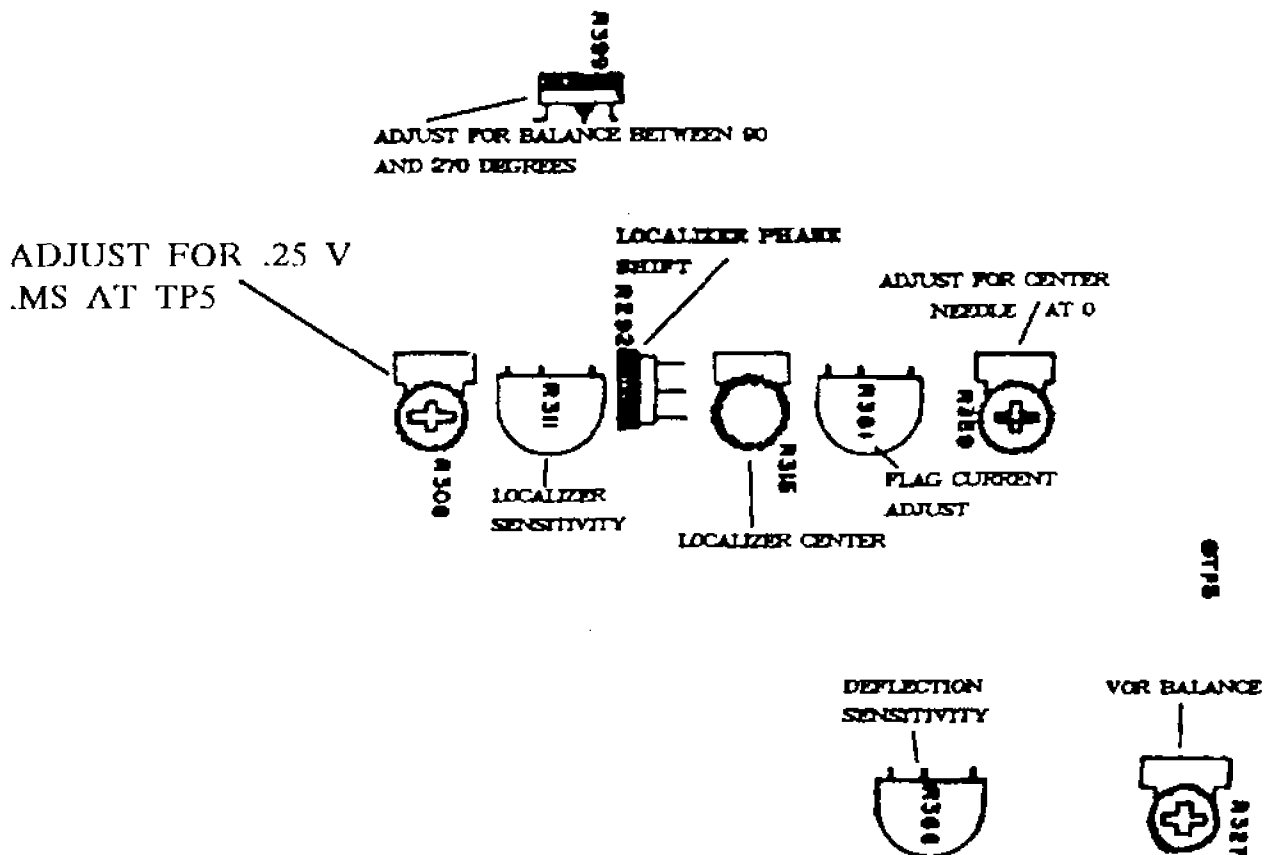

## The Technician's Notebook

By Jerry Gordon

# KX-155A

**Weight:** 069-01032-0101(With G/S) 4.2 lbs. 069-01032-0201 3.7 lbs.

**Height:** 2.0 inches      **Depth:** 10.16 inches

**Current draw:** 6.0 amps max (transmit)

**Nav Loads:** G/S flag/D-bar/VOR-LOC D-bar = 5-1000 ohm loads. VOR-LOC flag = 3-1000 ohm loads

To-From = 3-200 ohm loads. Audio Output = 500 ohm load (100 mw output)

**Comm receiver sens:** 2 $\mu$ V hard for 6dB S+N/N 1k tone @30%

**Transmitter** 10 watts, modulation 70% with <15% distortion. Sidetone up to 100 mw @500 ohms.

Rev. 0, Feb. 2000

### SERVICE BULLETINS:

**KX-155A-1** Applicable to SN 3999 and below. To see that all radios will meet transmitter power output when operating into a 3:1 VSWR. Also to provide attenuation of harmonic frequencies. This is a factor mod only.

**KX-155A-2** applicable two SN 3899 and below. To ensure that all radios meet FM immunity response standards for communications receivers. This is a factory mod only.

**KX-155A-3** Applicable to SN 3999 and below. This mod will enable the radio to operate on as little as 16 volts in an emergency. This is a factory mod only.

**KX-155A-4** Applicable to SN 3999 and below. This mod eliminates occasional muffled or missed first voice syllables during transmissions. It also incorporates new board connectors and interconnecting cables which will reduce fatigue and connector corrosion. It replaces C-250 and C-267 with ones with leads to prevent them from breaking. This is a factory mod only.

**KX-155A-5** Applicable to SN 11999 and below. This mod enhances the receiver and transmitter performance to TSO specs and reduces a self-induced 125.70 MHz interference. This is a factory mod only.

**KX-155A-6** Applicable to SN 4799 and below. This mod is to eliminate excessive sidetone distortion and increases maximum sidetone level. It incorporates changing a resistor, a capacitor, and changing a circuit path. Mods 1 through 4 must be installed before completing mod 6. Parts needed: 1 each of 139-06812-0010 68.1K resistor and 106-05103-0057 .01uf cap. Time required: 4 hours.

**KX-155A-7** Applicable to SN 11999 and below. This mod improves the stability of transmitter modulation, improves comm receiver compressor at the start of reception, and reduces display-related noise in the squelched com audio. This is a factory mod only. If unit is sent in for mod 5, it will receive mod 7 at the same time.

**KX-155A-8** Applicable to PN 069-01032-0101 and -0201, SN 14299 and below only if this unit is using the KLN-94 Quick tune feature. Consists of removing an IC, cutting 2 paths, drilling out 2 vias, adding 2 mag wires, and installing a new IC. Time required: 4.0 hours. Warranty reimbursable if completed within 2 years of the date of this service bulletin (Nov 99). For parts required and procedure see the SB.

### SERVICE AIDS:

**KX-155A-101** This aid describes how to modify a KX-155 test harness to work with a KX-155A. It consists of wiring 2 new connectors in parallel with existing KX-155 connectors and adding several switches and other connections. Consult the service aid for the wiring diagram.

**KX-155A-102** This aid shows revised test data for the KX-155A. The data will be included in the next revision of the maintenance manual.

**KX-155A-103** The volume knobs for the Com and Nav sections have been changed from a metal knob, to a plastic knob to feel cooler to the touch. The new knobs are PN 088-03412-0003. The change was started at SN 15000.

**SOFTWARE BULLETINS:**

**KX-155A-SW1** Applicable to SN 6499 and below. This bulletin replaces 01/01 software with 01/04 software. Recommended only if unit exhibits DME channeling problems. Parts required: 1 each of the following: 225-00014-0003 software disk (may be used to program multiple units) and 057-05287-0104, software mod tag. Time required 2.0 hours.

**MODIFICATION PROCEDURE**

The pieces of equipment needed to do this software change are:

1. A service shop-supplied serial cable with connections for the KX 155A RS 232 pins and the com mic key pin as shown in Figure 5-2 of the maintenance manual.
2. An IBM-compatible PC with a serial output port. (A small number of disk drives are incompatible with the Application Image Diskette. If your computer is unable to read the diskette, another computer will be required.) **This programming procedure should be used in lieu of the procedures in the KX 155A Maintenance Manual P/N 006-15542-0000, Rev. 0, Feb/97. This procedure will be added to the maintenance manual on its next revision.**
1. Connect the KX 155A to the shop-fabricated Test Panel as shown in Figure 5-2 in the maintenance manual.
2. Apply power to the unit, but do not turn the unit on.
3. Connect the RS 232 port of the PC to the RS 232 pins of the KX 155A using the serial cable mentioned above.
4. Insert the Application Image Diskette, P/N 225-00014-0003, into the floppy drive (assumed to be the A drive) of the computer.
5. At the DOS prompt, type a:\pcloader <enter>. (If the computer displays a message such as disk may be corrupted, incorrect disk - insert disk, or diskette compatibility error, then the computer's drive is incompatible with the diskette. Try using a different computer, or send the unit to AlliedSignal to be updated.)
6. Key (ground) the COMM mic key pin.
7. Turn on the unit.
8. Once the software loading is completed, a blue bar will appear across the screen.
9. Turn the unit off and on.
10. Test according to the testing procedure in this bulletin. If the 01/04 software does not load properly, contact AlliedSignal Customer Service, telephone number 913-782-0600, fax number 913-712-1306. It may be necessary to have the software installed at the AlliedSignal factory in Olathe, Kansas.

**IDENTIFICATION PROCEDURE**

Attach Unit Software Mod Tag P/N 057-05287-0104 over the old tag to indicate the change to unit software mod 01/04.

**TESTING PROCEDURE**

1. Check that the latest software version is displayed in the pilot configuration pages. To do this, press and hold the NAV mode button for more than 2 seconds. While still holding the button, press the NAV transfer button for an additional 2 seconds. The software version is indicated following SWRV.
2. Cycle power off and on to reset the unit.
3. Perform steps 1 through 7 of the final test procedure in the maintenance manual to check unit operation.

**THE FOLLOWING COURTESY OF BENDIX/KING PRODUCT SUPPORT**

**KX-155A TROUBLE SHOOTING/HELPFUL HINTS:**

- Always make sure the coax/load is applied to the comm antenna during transmit. The result of not doing so could short out Q-4006.
- **NAV SENSITIVITY PROBLEM:** First place to check is grounding on the Nav antenna/RF in port and/or cracked C-339. (This possibly can occur during tear down of unit.)
- **NAV COMPOSITE NOT ADJUSTING PROPERLY TO ALIGNMENT:** Heat C-3285 and see if composite voltage drops significantly. If so, then replace C-3285 and realign nav composite.
- When disassembling/reassembling the front panel assembly from the main chassis, be careful no to snag the comm on/off switch. This may damage the switch and may require replacement.
- During transmitter alignment, record compressor DAC setting before resetting to zero. This will be a good starting point during compressor re-alignment.

Note: The display assembly (037-05105-0001) is a gas discharge display and display driver board attached as a single assembly. There are no schematics to repair this assembly. It must be replaced as a unit.

**NOTES:**



# The Technicians Notebook

By Jerry Gordon

# KX-155/165

Revision No: 3 9/97

Weight: 4.75 to 5.5 lbs depending on version.

Transmitter power 10 watts min. Modulation 85%. Sidetone: to 100 mw in 500 ohms.

Com receiver sensitivity: 2 uv hard for 6db S+N/N 1khz modulated 30%. Receiver audio: 100 mw into 500 ohms.

AGC 3db from 5 uv to 20,000 uv. Nav receiver sensitivity: 2 uv hard for 1/2 flag. VOR AGC from 10 uv to 20,000 uv less than 1 degree change. AGC 3 db from 5 uv to 20,000 uv. Audio output: 100 mw into 500 ohms.

Glide Slope sensitivity: 20 uv or less for 60% of std. dev. Capable of operating 1 to 8 1000 ohms loads and 9 1000 flag alarm loads. No load resistors are required. Audio amp: 4 watts in 4 ohms (13.75V), 8 watts in 4 ohms

## SERVICE BULLETINS:

**KX155-1/KX165-1** (applicable to KX-155 SN 25089 and below (14V) SN 35300 and below (28V), KX-165 SN 1116 and below (14V) and SN 10181 and below (28V)). To reduce the digital noise in the Nav audio output. Parts required 1 ea. KPN 050-2012-00 kit. Time required 1.5 hours.

**KX155-2/KX165-2** (applicable to KX-155 SN 25327 and below (14V) SN 35429 and below (28V), KX-165 SN 1256 and below (14V) and SN 10460 and below (28V)). To improve RFI protection and prevent the microprocessor from resetting in the presence of a strong RF field. The modification consists of adding C-544 & C-548 to the main board. Parts required 5 ea. KPN 111-00001- 0007. Time required 1.5 hours.

**KX155-3/KX165-3** (applicable to KX-155 SN 25699 and below (14V) SN 35699 and below (28V), KX-165 SN 1499 and below (14V) and SN 10699 and below (28V)). Serial numbers above those stated have been modified during manufacturing. SN 25700-26221/35700-35913 inclusive have been modified but not stamped on the mod status tag. These only require an "X" on the tag. To prevent memory loss of stored frequencies. Time required 4.0 hours. Warranty credit if modification is performed by a King Service Center.

**KX155-4/KX165-4** (applicable to all serial numbers) To convert from 25 KHz to 50 KHz sensitivity. Modification alters the receiver selectivity by replacing FL-200 and deleting C228-230. Time required 1.0 hours.

**KX155-5/KX165-5** (applicable to all serial numbers) To convert from 50 KHz to 25 KHz selectivity. Replace FL-200 and add C228-230. Time required 1.0 hours.

**KX155-6/KX165-6** (applicable to KX-155 SN 25932 and below (14V) SN 35819 and below (28V), KX-165 SN 17660 and below (14V) and SN 10800 and below (28V)). This will cure Com Transceiver and Nav receiver channeling malfunctions. Time required 1.5 hours. In order to ensure warranty payment, the claim must be marked to show that mod 6 was performed.

**KX155-7/KX165-7** (applicable to KX-155 SN 26647 and below (14V) SN 36208 and below (28V), KX-165 SN 2310 and below (14V) and SN 11348 and below (28V)). Prevents weak glide slope sensitivity which is caused by an oscillation in the glide slope converter reference amplifier. Mod consists of adding a 1K ohm resistor from the reference amplifier output to ground. Time required 1.5 hours.

**KX155-8/KX165-8** (KX155 applicable to SN 27473 and below (14V) SN 3600 and below (28V))((KX-165 applicable to SN 2800 and below (14V) SN 11700 and below (28V)) To prevent intermittent power supply resetting. Consists of adding C-582 capacitor in the microprocessor circuit. Time required 2.0 hours.

**KX155-9/KX165-9** (KX155 applicable to SN 27950 and below (14V) SN 36955 and below (28V))((KX-165 applicable to SN 2976 and below (14V) SN 11785 and below (28V)) To improve squelch operation in noisy environments. Consists of replacing Transistor Array I203 in the squelch circuitry with discrete transistors Q224-Q228. The values of R264 & R266 are also changed. Time required 3.0 hours.

**KX155-10** No service bulletin issued.

**KX-165-10** (applicable to SN 3100 and below (14V) and SN 11750 and below (28V). Improved localizer flag operation. Replace R-668 with a 47.5 K ¼ w resistor (136-04752-0072), R-669 with a 30.9 K ¼ w resistor (136-04322-0072), and R-682 with a 68.1 K variable resistor (133-00096-0037). Apply standard VOR signal, reference phase only. Adjust R-682 for 120 ua flag current. Set the generator for .4 DDM. Check that the flag current is 260 ua minimum. (left and right).

**KX155-11/KX165-11** (KX155 applicable to SN 28506 and below (14V) SN 36888 and below (28V))((KX-165 applicable to SN 3095 and below (14V) SN 11743 and below (28V)) Eliminates mode switching problem when interfaced to the King KN-74 Aura Nav Computer. Time required 1.0 hours. Covered by warranty.

**KX155-12** (applicable to KPN 069-1024-00/04/08/09) Adds glide slope option. With this modification, a KPN069-1024-00/04/08/09 is functionally equivalent to a KPN 069-1024-01/05/12/13. Consists of adding a glide slope assembly to a KX155 which does not have the glide slope option. Time required 1.5 hours.

**KX155-13/KX-165-12** (KX-155 applicable to SN 51914 and below (14V) SN 40868 and below (28V))((KX-165 applicable to SN 4372 and below (14V) SN 13683 and below (28V)) Prevents the voltage regulator from oscillating if the input voltage reaches a certain level. Consists of adding a capacitor across the input of the voltage regulator. Time required 2.0 hours.

**KX155-14/KX165-13** (Applicable to all KX-155 part numbers 069-1024-00 through 069-1024-13/KX-165 part numbers 069-1025-00 through 069-1025-07) Allows use of WARC frequency assignments that became effective in the year 1990, changes the microprocessor, adds a software identification tag and changes the part number of the transceiver. Time required 1.0 hours.

**KX165-14** (Revised) This modification consists of adding a glide slope receiver to a KX-165 which was not manufactured with a glide slope receiver. Parts required: mod kit 050-02773-0000 (Includes glide slope receiver). Estimated time to modify: 2.0 hours. Instructions are in the mod kit.

**KX155-15/KX165-15** (KX-155 28 Volt units SN 12018 and below, KX-165 28Volt units SN 48549 and below.) Q-313, Modulator transistor (007-00345-0001) Replaced by 007-00964-0000 (MJ11028). Recommended only if failure of Q-313 occurs.

**KX155-16/KX165-16** (KX-155 P/N 069-1024-00/01/02/03/08/10/12/30/31/32/33/38/40/42, SN and below, KX-155 P/N 069-1024-04/05/06/07/09/11/13/34/35/35/37/39/41/43, S/N 114999 and below, KX-165 P/N 069-1025-00/01/02/03/20/21/22/23, S/N 154999 and below, KX-165 P/N 069-1025-04/05/06/07/24/25/26/27, S/N 54999 and below.) This modification requires the latest display board as installed with Mod 3. Display board replacement kit P/N 050-01902-0037 (for the KX-155) or 050-01802-0037 (for the KX-165) may be required. This modification is to meet the requirements of ICAO ANNEX 10 for FM broadcast interference immunity. This mod is a product improvement and is not warranty reimbursable. See the bulletin for further information.

#### **SERVICE AIDS:**

**SA KX155/165-101** Removal of finger stock to prevent shorts. Finger stock and associated hardware can be deleted. Removal of the top cover grounding will not have and significant change in the KX155 or system performance.

**SA KX155/165-102** (KX155 applicable to SN 27301 and below (14V), SN 36600 and below (28V), (KX-165 applicable to SN 2800 and below (14V), SN 11702 and below (28V). To change dimming ratio to accommodate Beckman displays. Change R429 from a 68K ohm, EW, 5% resistor to a 75K ohm, EW, 5% resistor, KPN 131-0753-13. Change R434 from a 15K ohm, EW, 5% resistor to a 24K ohm, EW, 5% resistor, KPN 131-0243-13.

**SA KX155-103** Diode, KPN007-6070-00 is no longer available. Replace it by KPN 007-6228-00.

**SA KX155-104/KX165-103** Redirection of the attack time to audio compressor. (80 milliseconds to approximately 20 milliseconds. Change the value of C265 from a 10 microfarad capacitor to a 4.7 microfarad capacitor (KPN 097-0104-10). Replace R3009 with a circuit jumper (KPN 026-0018-01).

**SA KX155-105/KX165-104** Replacement of obsolete field effect transistors SD305DE, SD306DE, and 3N225. Replace SD305DE with 3N212, KPN 007-0452-00. Replace SD306DE with MFE521, KPN007-0310-00. Replace 3N225 with 3N212, KPN 007-0452-00. Kit KPN 050-2638-00 is available to replace the obsolete transistors in one KX155.

**SA KX155-106** Removal of integrated circuit sockets.

**SA KX155-107** Improved 60 db selectivity over a wider temperature range.

**SA KX-155-108/KX-165-107** To provide more range for the mike compressor adjustment. R-594 is changed from a 500 ohm pot to a 1K pot (133-00113-0012) Alignment procedure is not affected.

**SA KX-165-108** Revised alignment procedure for VOR/LOC converter. The manual omitted the adjustment of R-603. See VOR/LOC converter board section in "Trouble Shooting Hints From Bendix/King" section.

### **EXCERPTS FROM SERVICE MEMO 310 (REVISED)**

#### **DISPLAYS:**

Maintaining a good hermetic seal between all pieces of a display has turned out to be rather difficult. The goal for the displays has been to typically last at least three years. The most frequent failure mode of the gas discharge displays has been the gas escaping from the display. The display manufacturer developed an improved process of bonding the glass pieces together. Displays with the improved seal were identified with a blue or purple dot of paint on the rear of the display. The cause of the fractures in the purple dot display seals was traced to a chemical reaction between silver and mercury (Hg) which resulted in a physical swelling of the circuit paths within the display.

To prevent the silver and mercury chemical reaction from fracturing display seals, the display circuit paths were redesigned to eliminate swelling close to the seal. Displays with this artwork change were identified by a white dot. White dot displays combine the improved fit seal of the purple dot displays with a newer designed circuit path layout. This improved the reliability of the display. As confidence was gained in the white dot configuration, the white dot was eliminated.

The main cause of failures now is caused by stress placed on the display while installing or while the radio is installed in the aircraft. When replacing a defective gas discharge display, there are some general items to check. The goal is to minimize any stress placed on the display as it is installed in the unit. As the bezel assembly is removed, inspect the inside or back of the amber lens material for evidence of the display hitting the lens.

If any sign of interference is found, attempt to slide the circuit board which mounts the display socket or display board to the rear of the radio as far as possible. Loosen all mounting screws before attempting to slide the circuit boards. Reinstall the display and bezel assembly. If any force must be applied to line up bezel mounting holes with the rails of the unit, it is possible that the bezel assembly has the mounting holes drilled in the wrong location, or the lens material is too thick, or the lens material does not have a relief hole for the epoxy dot which is found on the front of some displays. If any of the above symptoms are found, the bezel assembly should be replaced or reworked.

The part numbers for completely assembled bezel assemblies are as follows: KX-155 200-02911-0000, KX-165 200-02900-0001.

If multiple failures of the display have occurred and no sign of stress can be found in the radio itself, examine the aircraft installation to make sure no stress is put on the display by the aircraft installation. An analysis of failed displays, in the early part of 1986, revealed silver migration as the cause for some display failures. The silver migration appears as a thin black deposit of material between the anode and cathode contacts. A humidity barrier has been devised to prevent the collection of moisture and hence silver migration from occurring. This can be accomplished in the field by the application of Dow Corning #4 Compound, KPN 016-01207-0000, or other silicone dielectric grease meeting the requirements of Mil-S-8660B Amendment 3, in the groove between the anode and cathode glass of the display. DC-4 on the contacts will not impede operation.

Condensation moisture can also be a problem for the display contacts and the display socket contacts. If only certain digits or segments are inoperative in the display, and display multiplex circuitry is operating properly, examine the display socket and display connector for signs of dirty contacts or corrosion. Try an alcohol based solvent and soft brush to clean the contacts, being careful not to bend the contacts of the display socket. Make

sure contact pressure of the display socket is adequate. After cleaning use DC-4 or equivalent to prevent future corrosion and dirty contacts. Proper application is as follows:

**A:** On a clean display, apply a thin layer (approximately .025 inches thick) of silicone grease directly on the display connector.

**B:** Plug the display into the socket.

**C:** With a brush, carefully apply silicone grease on to the exposed contacts, both top and bottom. The objective is to cover all exposed areas of the display connector and display sockets.

**D:** Any excess silicone grease may be carefully removed with small wooden stick such as a "tongue depressor." Also, if any silicone grease gets onto the display viewing area, the alcohol-based solvent can be used to clean the glass.

This procedure is especially helpful in heavy moisture environments.

## **TROUBLE SHOOTING HINTS FROM BENDIX/KING CUSTOMER SERVICE:**

### **POWER SUPPLY TROUBLE SHOOTING TIPS**

No power supply voltages or very low. Lift R426 and check for the presence of pulse width modulator output. 50% duty cycle square wave. Isolate outputs by lifting diodes one at a time. Remember, you must never lift the 5V and 10V at the same time.

### **DISPLAY BOARD TROUBLE SHOOTING TIPS**

In many cases failure of the display is caused by the display itself. Always try a new display first. If CR-104 fails, it may be necessary to replace I101, I102, CR-104, and CR-103 at the same time. Mod 3 removes the -00/01 display board and replaces it with the -10/11 display board. Mod 3 is warranty reimbursable. The microprocessor must match the board or channeling problems will occur.

Display board 200-6068-00/01 uses 1407 micro 120-2094-00. Display board 200-6068-10/11 uses 1407 micro 120-2094-02 or extended freq. 120-2094-10. See mod 13 KX 165 & mod 14 KX 155 - 760 channels. An easy way to tell if your display board is -00/01 or -10/11 is to rotate any of the channeling knobs 360 degrees and count the clicks. The -00/01 board has 8 clicks for 1 full turn and the -10/11 board has 12 clicks. Remember the boards are different, so are the detent wheels and plastic switch housings.

### **RECEIVER**

Tuning voltage must be stable with no noise. If you are unable to get 8 volts of tuning voltage at 135.975, replace the varactors as a set. If the receiver is weak, your best bet is to try signal injection. If the tuning voltage is excessively low at all frequencies R223 in Com or R368 in Nav receiver may be lifted to isolate VCO tuning voltage loops from preselectors.

### **TRANSMITTER**

Check for modulation and modulation line voltages. If current draw is high with no transmitter power out, the problem is usually in final stage or after. Each stage of the transmitter has a voltage gain of 3 times, also seen across the output transformer.

### **GLIDE SLOPE BOARD**

Double-check RF AGC adjustment. If misadjusted, you will have a weak receiver. G/S alignment procedure corrections from page 5-18 rev 5. Line 5.2.16.3, c. Set the HP 200CD for 162 KHz (-00 Brd) or 170 KHz (-10Brd). Line 5.2.16.3 f. Set the HP 200CD for 83.6 KHz (-00Brd) or 88.9 KHz (-10 Brd).

### **VOR LOC CONVERTER BOARD**

Step 1 of VOR LOC converter alignment. R603 alignment: Monitor pin 7 of 1600 with a standard VOR signal applied. Remove 30 HZ AM modulation. Adjust R603 for minimum 60 HZ AM ripple. (Point to remember: 30 HZ reference goes out J901, pin 2 (rotor C) and comes back in J901, pin 3 (stator F), OBS resolver phase shifted.)

### **NOTES:**

C-464 (.68 mfd) off microprocessor was masked wrong. The + side of the cap should go toward the microprocessor. VCO not oscillating. Check C-259, C-260, and C-263.

Weak nav or com receiver: Check voltage on top of the following caps:

Com C-259, C-260, C-216, C-217, Nav C-302, C-304, C-316, C-318. The voltage on each cap in the set should be the same. If one is lower than the rest, replace the cap. Part number for display: 037-00073-0000

For a complete set of The Technician's Notebook, call (616) 652-1259 Visit our web site at [www.riverview.net/gordon](http://www.riverview.net/gordon)

# The Technician's Notebook

By Jerry Gordon

# KX-170B

Revision 1, July 1994

Weight 7.0 lbs., unit only, Transmitter power 5 watts min.  
Com receiver 1.5  $\mu$ v 6db s+s/n. AGC 10 uv-20,000  $\mu$ v  $\pm$  3db.  
Nav receiver 1.0  $\mu$ v 6db s+s/n. 1.5 uv for omni half flag.  
AGC 10uv - 20,000  $\mu$ v  $\pm$ 3db.  
Nav output .35 Vrms, Localizer, .5 Vrms VOR  
Phone out 50 mw -500 ohms. Spkr out 5 watts

---

## SERVICE BULLETINS:

**KX-170B-1** (applicable to SN 22971 & below) 400 Hz interference to nav audio output state. Primarily caused by KWX40 Radar system. Kit (050-01414-0000). Time required 1 hour.

**KX-170B-2** (applicable to SN 22971 & below) Intermittent Nav SMO lockup on 108 & 109 Mhz channels (1 ea. 13k 5% 1/4 w res.) Time required 1 hour.

**KX-170B-4** (applicable to SN 26924 & below) KX-170B connected with a KN-77 and a KN-73, a VOR error is caused in the KN-77 on all .05 Khz Nav channels above 112.0 Mhz (1 ea. 007-06033-0000). Time required 1 hour.

**KX-170B-5** (applicable to SN 46794 & below) Automatic squelch in com adversely affected by high levels of radiated ignition noise decreasing range. (2 ea. 007-06106-0000)-Time required 1 hour.

**KX-170B-6** (applicable to SN 48900 & below) Change C407 to reduce possibility of shorting. (1 ea. 096-01030-0007)-Time required 1/2 hour.

**KX-170B-7** (applicable to SN 56611 & below) Audio output transistors 007-0197-00 no longer available. It is easier to replace the complete heat sink assembly than to replace the transistors.(1 ea. 250-01515-0012)-Time required 2 hours.

**KX-170B-8** (applicable to SN 66499 & below) Incorporation of the new style transmitter board and modulation transformer when replacing a transmitter assembly. (1 ea. 200-00083-0000 and 1 ea. 019-05062-0001)-Time required 3 hours.

**KX-170B-9** Modification to meet RTCA DO-156 For international approval (Kit 050-01614-0002)-Time required 2 hours.

**KX-170B-10** Modification for operation to 136.975 Mhz (Kit 050-02697-0000)Time required 5 hours.

## SERVICE MEMOS:

**SM 177** (applicable to SN 35000 & below) Units after this serial number have the new style face plate with micro-switches.

**SM 223** Intermittent volume controls coded 7638 or 7645. Replace with new units. (133-00059-0000)

**SM 227** (applicable to SN 45160 & above) Product improvement that incorporates adjustable switch wafer mounting plate to alleviate binding problems.

**SM 232** Unit hold down pawl (white) replaced by improved (black) style. (088-00125-0001)

**SM 235** Improved com Khz wheel assembly. When it is necessary to replace the 100 Khz wheel, the 25Khz wheel, or the transfer plate, all three must be updated to the new style at the same time.

## SERVICE AIDS:

**SA KX 170B-101** (applicable to SN 69825 & below) Replacement of transfer gears in com kHz wheel assembly. 088-0232-01 no longer available Replaced by metal style 029-00286-0000.

## TIPS AND HINTS:

Differences between KX-170A and KX-170B: KX-170A is 360 channel and KX-170B is 720 channel Units are interchangeable.  
Differences between KX-170 and KX-170A: KX-170 supplies 2 out of 5 channeling for DME and Glide Slope, KX-170A furnishes slip code. Differences at main connector are as follows:

Pin	KX-170	KX-170A/B
1	spare	A+ input
19	spare	ILS common
26	DME "E"	Nav switched

### The following is courtesy of Bendix/King Customer Support:

Common problems associated with the KX-170 series are the mounting lock assemblies holding the units in the rack While inserting or removing the units excessive torqueing is applied to the mounting lock spinning it around and breaking or cracking the S103 channeling wafer. If the bench technician has an intermittent SMO or intermittent operation, he should check S-103 for cracks. Also look at the mounting lock.

**SMO:** The tuning voltage low at TP 301. Make certain the problem is not a wafer problem before you start trouble shooting the SMO. If the VCO is working, check TP-306 for 4 or 5 volts DC square wave signal. This is the quickest way to isolate between an analog problem or a digital logic problem. Some technicians, finding no tuning voltage, go immediately to the phase/frequency comparator circuit. The VCO is the heart of any SMO operation and if it is not correct, the phase/frequency comparator will not operate. In the digital logic, you can compare the NAV SMO to the COM SMO for trouble shooting comparison. The only difference is the divider codes from the wafers. Check the switching lines from the wafers to the SMO for changing logic. A line may short or open and will not change while channeling. An intermittent relay can cause problems making the high band inop on transmit and the low band inop on receive or vice-versa.

Unit inop in the middle of the band: Warped wafer switches caused by the mounting lock Covered by Service Memo #232. Installation of a new lock assembly. The old ones were white nylon and the new ones are black plastic. The new style is stronger and less apt to break loose while turning thereby breaking the wafer switches. It is still possible to force the new style beyond the stop so be careful.

Another problem encountered at the factory is units being returned after shops have changed one of the kHz dials and do not change them all (Re: Service Memo #235). If you change the kHz dial you must change the metal transfer plate that separates them.

Face plate inserts are available for the cosmetics of old face plates. There is a complete face plate assembly that is available, including gears, switches, and controls. The part number for the assembly is 050-01666-0000. It used to be economically reasonable to replace the assembly. The price has risen quite a lot which makes in a little more feasible to purchase the face plate inserts and new knobs for a face plate lift. Regarding knobs, there are 3 different types of knobs used on the KX-170's. The metal knobs for the round shaft are no longer available. The new metal knobs with the "D" shaft hole will have to be drilled out in a drill press or the shafts on the radio will have to have a flat spot filed to fit. The plastic knobs have the silver edge, are a "D" shaft, and are not listed in the manual. The part numbers for the new plastic knobs are: mHz: 088-00729-0002, kHz: 088-00730-0002, Volume: 088-00731-0002.

Receiver problems: The com mode tuning voltage and the com pre-selector tuning voltage are different tuning voltages. The com mode tuning voltage is the tracking voltage in the com SMO and the preselector tuning voltage comes from voltage dividing resistors on the tuning wafer switch S-103. These two tuning voltages, however, in the nav receiver are the same.

No receive problems: No receiver noise, no IF noise, AGC voltage low, detector voltage low, usually means poor IF gain. Not enough signal coming from the IF to drive the detector, thus the AGC voltage is low. If the AGC voltage is low and the detector voltage is at supply potential, you have an AGC problem. Weak receive can be an IF crystal problem.

Check the zener diodes!!

FM in the nav receiver, replace C429 & CR410.

New part number for the audio final assembly is 250-01515-0012. Change the assembly if you have bad audio output transistors. Y301 & Y302 can be off tolerance at the same time. Volume Control PN133-00059-0000 replaced by PN133-00564-0000.

The modification to the KX-170, KX-170A, KX-175, KX-175A, KY-95 to bring the radios to within the frequency tolerance required by the FCC requires kit number 050-02932-0000.

Mounting rack (equipment cover) for the 170 series radios: KPN 047-01695-0000. Screws to mount the cover plate are 089-06258-0004. Replacement caps for the defective .1 red caps are 114-07104-10000.

Old style 031-00114-0000 on off switches are quite often bad. The new face plate kit includes new switches and could be a very good reason for spending the money. Even the new style micro switch on/off switches can get resistive. If you appear to have a low power supply output voltage you might measure the input voltage across the micro switch while the set is operating and check for a voltage drop. New style micro switches are 031-00264-0000.

Receiver sensitive problems can be trouble shot using an ADF signal generator for injection of signals. 100  $\mu$ v injected in the 2nd IF should be adequate in both com and nav. 30-50  $\mu$ v through the crystal filter should give a good signal to noise ratio. Trouble shooting using the signal to noise ratio is superior to monitoring the AGC voltage because some units are just noisier than others.

#### NAV SMO ALIGNMENT:

Check for 8.3 volts at anode of CR 101. Nav frequency to 117.95 and adjust L201 for 7.2 vdc at TP201.

#### COM SMO ALIGNMENT:

Com freq. selector at 122.5 mHz, adjust C334 for 131.5 at point "Y". Com freq. selector at 131.5, adjust C332 for 122.5 mHz at point "Y". Com freq. selector to 126.975, adjust C315 for 7 vdc at TP301. Com freq. selector to 135.975, adjust C314 for 7 vdc at TP301.

**MIKE AUDIO INPUT:** .4 vac (unloaded) for 85% modulation.

#### COM SYNTHESIZER TROUBLE SHOOTING TIPS: (Courtesy of Jeff Young, Mayday Avionics)

##### *IF TOTALLY INOP:*

1. Check pin #3 of I-307 for pulses.
  - a. If no pulses, check pin #1 for pulses.
  - b. If no pulses and low, change I-307 if pulses are at pin #2.
  - c. If no pulses and high, check I-303 for proper logic of all nand gates.
  - d. If I-303 checks good, check logic of I-308, NOR gates.

##### *IF IMPROPER FREQUENCIES:*

1. Check M and K lines at the feed throughs
  - a. If logic changes states as unit is channeled, check I-301, I-302 and I-306.
  - b. If channeling does not appear at the feed through caps, check them for shorts.

When removing the IC's, be sure to re-tin the plating under the IC's. Poor solder connections after the chip is changed can cause problems hard to locate.

1. Low mHz works, high mHz inop. Or the reverse.
  - a. Check Y-301 & Y-302 switching.
  - b. Replace bad crystal if found bad.

Nav synthesizer is similar. Try not to get too "Digital" in trouble shooting the units. Most signals should be "Strobing" without having to resort to logic tables.

#### NOTES:

# The Technicians Notebook

By Jerry Gordon

# KY-196/197

Weight 3.2 lbs. Transmitter Power KY-196 16 watts Min, KY-197 10 watts min.

Receiver Sensitivity 2 uv (hard) for 6db s+n/n with 1 khz mod 30%

AGC 5 uv to 20,000 uv <3db.

Audio output 100 mw into 500 ohms.

Sidetone up to 100 mv into 500 ohms.

Revision No: 2 10/97

**THE ONLY DIFFERENCES IN THE KY-196 AND KY-197 ARE THE INPUT VOLTAGE AND THE TRANSMITTER POWER.**

## • SERVICE BULLETINS:

**KY-196-1** (applicable to s.n. 1413 & below) **KY-197-1** (applicable to s.n. 70247 & below) Prevent the display from flashing or blanking when in bright sunlight. Consists of changing 3 resistors and cutting 3 paths. Time required 2 hours.

**KY-196-2** (applicable to s.n. 1575 & below) **KY-197-2** (applicable to s.n. 70901 & below) Prevent the transmitter from radiating in receive mode. Consists of adding a capacitor (C-631, 113-03470-0000) to the transmitter board. Time required 1.5 hours. (Still covered by King Warranty.)

**KY-196-3** (superseded by KY-196-13) **KY-197-3** (applicable to s.n. 70314 and below) Prevent the SMO from unlocking on the high end of the band. Consists of adding a resistor, R233, to the main board to match the impedance of the SMO. Time required 1.5 hours.

**KY-197-4** (applicable to s.n. 71800 and below) Reduces ambient noise in the COMM receiver audio and improves the stability of the squelch settings over the operating temperature range. Consists of changing the values of C332, R344, R345, R346. Time required 1.5 hours.

**KY-196-4** (applicable to s.n. 3430 & below) **KY-197-5** (applicable to s.n. 71800 and below) Replaces intermittent potentiometers that have caused intermittent modulation, squelch and sidetone. Consists of changing R130, R159, R167, R338, R348, to a new style which is more reliable. New style has a white top. Time required 1.5 hours. SEE SERVICE AID KY-197-110!

**KY-196-5** (applicable to s.n. 4456 & below) Transmitter garbling due to T/R diode breaking down. Consists of adding CR-605 diode in series with CR-603. (Kit 007-06099-0000) (2 diodes). Time 1.5 hours. Warranty for mod still covered on all units if you find one needing it.

**KY-196-6** (No service bulletin assigned.) **KY-197-6** (applicable to s.n. 71799 and below) Improves the stability of the transmitter and reduces transmitter spurs. Consists of changing the values of L602 and L606. Requires 2 ea. 019-02084-0004. Time required 1.5 hours.

**KY-196-7/KY-197-7, KY-197-8** No service bulletins assigned.

**KY-196-8** (applicable to s.n. 8599 & below) **KY-197-9** (applicable to s.n. 74416 and below) Eliminates intercom MIC audio bleed through to the speaker. Consists of changing R160 to a circuit jumper and changing the values of R221, R161, R162. Time required 1.0 hours.

**KY-196-9** (applicable to s.n. 9139 & below) **KY-197-10** (applicable to s.n. 74843 and below) Prevents re-radiation in dual transceiver installations. Consists of adding a diode and resistor to the unit. Must be performed in conjunction with Installation Bulletin #194. Time required 5.5 hours.

**KY-196-10/KY-197-11** No service bulletin assigned.



**KY-196-11** (applicable to s.n. 11350 & below) **KY-197-12** (applicable to s.n. 76285 and below) Prevents the inability of unit to retain last used frequencies in memory during power down conditions. Consists of changing the microprocessor, I111, to a new style, changing I112 to a new style EAROM, and installing an additional modification status decal. Time required 1.0 hours.

**KY-196-12, KY-197-13** (applicable to all serial numbers) To convert the KY 197 with 25KHz selectivity, to 50KHz selectivity. Consists of removing FL301, 302, 303, 304 and C363, 364 and installing FL305, 306, 307, 308 in place of old filter. Time required 1.0 hours.

**KY-196-13** (applicable to s.n. 12016 & below) **KY-197-14** (applicable to s.n. 76572 & below) Improve carrier/noise squelch operation and improve carrier squelch tracking across the frequency band. Consists of changing some components (KY-196 s.n.. 10625 through 12016 or KY-197 s.n. 75817 through s.n. 76572) or changing the receiver board assembly (KY-196 below s.n. 10625 or KY-197 below s.n. 75817). This mod is recommended whenever abnormal automatic squelch operation is noticed. Time required 2.5 hours.

**KY-196-14/197-15 Revised** (applicable to any serial number) Prevents intermittent double transfer of frequencies from the STANDBY to the USE windows of the display. Consists of a new microprocessor with the capability of storing up to 9 preset frequencies into memory and allows "direct" tuning of frequencies into the active window.

**KY-196-15/KY-197-16** (applicable to any serial number) Adds remote frequency transfer and remote memory increment capability. Consists of adding a Remote Frequency Transfer/Memory Increment Board Assembly to the unit. (Kit 050-2194-00)

**KY-196-16** (applicable to any serial number) Extend frequency range to 138.975. Kit 050-02203-0000. Time required 1.5 hours.

**KY-196-17** (applicable to s.n. 15628 & below, Unit KPN 064-1019-00 through -42 (except -01)) **KY-197-17** (applicable to s.n. 79139 & below, Unit KPN 064-1021-00 through -32 (except -01)) Lowers the impedance of the increment/decrement lines into the microprocessor to prevent intermittent channeling. Consists of changing the value of R109 from 47K ohms to 6.2K ohms. It adds pull-up resistors to the PULSE and UP increment/decrement lines into the microprocessor. Time required 1.5 hours.

**KY-196-18** (applicable to s.n. 16718 and below) **KY-197-18** (applicable to s.n. 78535 and below) Minimizes local oscillator radiation. Consists of adding six capacitors, three ferrite beads, one shield, and changes four resistors. (Kit 050-02620-0000) Time required 3.0 hours.

**KY-196/KY-197-19** (applicable to KY-196 s.n. 18943 and below, KY-197 s.n. 79615 and below) Prevent voltage regulator from oscillating if the input voltage reaches a certain level. It can blank the display and cause a loss of memory resetting the display to 120.00 MHZ. Frequent complaints of memory loss that cannot be confirmed should have this mod performed. Consists of adding a .33 uf 500 volt capacitor (KPN 111-00001-0026) in parallel with CR-117. Time required 1 hour.

**KY-196/197-20** (applicable to all serial numbers) Frequency range extended to 136.975. KY-196 must be mod 14 and KY-197 must be mod 15. Kit 050-02702-0000. Time required 1 hour.

- **SERVICE AIDS:**

**SA KY-196/197-101** (applicable to s.n. below 72739) Transmitter garbling improved if the VCO fence on the receiver is soldered on both sides. C608 in the transmitter should also be soldered on both sides.

**SA KY-196/197-102** (applicable to s.n. 74151 and above) Product improvement to decrease noise level from the audio output. Consists of adding C197, a .1ufd, 100VDC capacitor, KPN 111-00001-0022, from the junction of R220 and terminal 3 of T103 to ground. Brings noise level down to 4MVRMS or less.

**SA KY-196/197-103** Increases the size of F101, the input power fuse. Changed to a 10 amp, 32 volt, AGA fuse, KPN 036-00058-0007. Prevents the fuse from blowing during transmitter operation.

**SA KY-196/197-104** (applicable to s.n. 71799 and below) The frequency transfer switch, SW101, is KPN 031-00357-0002 and the push button is KPN 088-00827-0001. (applicable to s.n. 71800 and above) the transfer switch has been changed to KPN 031-0370-00, the switch holder is KPN 088-00831-0000, and the push button is KPN 088-00827-0011.

**SA KY-196/KY-197-105** (applicable to units manufactured between August, 1983, and January 1984) DME PRF noise in audio. A clicking noise, the result of the audio amplifier (I119) picking up the DME transmitter's PRF. Happens when the KY-197 is mounted directly above a KNS 80 and when the I119 is an LM 1877N. Replace it with an LM 378N.

**SA KY-196/197-106** Q-103 transistor change to prevent timing problem of gas-discharge display, evidenced by some unwanted segments lighting, even dimly. New transistor, FPN 4275, (KPN 007-00151- 0000) eliminates this problem.

**SA KY-196-107 (applicable to s.n. 18100 and below), 197-107** (applicable to s.n. 79343 and below) To improve the reliability of the remote memory increment feature at cold temperature, two resistors on the Remote Memory Increment/Transfer Board, KPN 200-06687-0000, need to be changed. Replace the 160K ohm resistor (R704) with a 16K ohm resistor, KPN 131-00163-0013. Replace the 82K ohm resistor (R705) with an 8.2 ohm resistor, KPN 131-00822- 0013.

**SA KY-196/197-108** Diode CR-601, KPN 007-06070-0000 is not available. It is replace by diode, KPN 007-06228-0000.

**SA KY-197-109** (applicable to s.n. 79164 and above) Component changes were made to facilitate the manufacturing process. The purpose of this service aid is to provide current drawings that will reflect the new values, locations and part numbers.

**SA KY-196-109** (applicable to s.n. 17695 and below), **SA KY-197-110** (applicable to s.n. 79163 and below) Improved "mic" gain potentiometer. It has been changed to a ten turn potentiometer, Kit 050-02626-0000. Highly recommended change to make if any modulation problems are incurred.

**SA KY-196-110, KY-197-111** VHF Communication Transceiver. The field effect transistors SD305DE (Q-303) and SD306DE (Q-302) are obsolete and have been replaced. Q-303 is replaced by F.E.T. 3N212, KPN 007-00452-0000 (when Q-303 is replaced with the new type, R-318 must be replaced with a 100 ohm resistor KPN 131-00101-0023) and Q-302 is replaced by F.E.T. MFE521, KPN 007-00310-0000. A kit containing both F.E.T.'s and the resistor is available as KPN 050-02637-0000.

**SA KY-196-111, KY-197-112** Display brightness. When replacing a King display with a Dale display, or vice versa, the photocell dimming adjustment, R130 will have to be readjusted for the pulse width that is appropriate for the particular display.

**SA KY-196-112** Replacement of Q-121/122 modulator transistors. PN 007-00345-0001 have been replaced by PN 007-00963-0000. They are directly interchangeable.

**SA KY-196/197-113** Display board PN 200-06044-0000, is no longer available. It is replaced by Kit PN 050-01802-0058. If the display board is replaced using this kit, it will also incorporate KY 196/196E Mod 14 on a KY 196/196E or Mod 15 on a KY 197/197E. Refer to SB KY 196/196E-14 for more information.

• **ALIGNMENT QUICK REFERENCE:**

Check voltage regulator at TP-106 for 9.00 vdc. Check voltage at TP-103 and adjust VCO (L313) for 8.00 vdc at 135.975MHZ. With counter at junction of C-361 & C-330 (access hole on rear of receiver board), select 135.975 MHZ and adjust C-109 for 147.375 MHZ on counter. Must be done within 1 minute of turn at room temperature. RF/IF alignment: At 126.5 MHZ connect generator through 6 db pad. With squelch knob pulled out insert enough signal for approximately 5 volts at TP-103. Adjust L-302, L-304, L-306, L-308, T-301, T-302, T-303, and T-304 for maximum voltage at TP-103. Keep input signal low enough to show around 3.0 volts at TP-103. Noise squelch adjust: With RF generator input at 25 hard uv modulated 85% with 8KHZ, adjust L-309 for maximum p-p voltage

at TP-306. With 2.0 hard uv modulated 30% with 1KHZ, adjust R-348 (noise squelch) clockwise until just squelched. Carrier squelch adjust: KY-196 prior MOD 13 and KY-197 prior MOD 14, with RF generator at 25 hard uv modulated 85% with 8 KHZ, adjust R-338 until unit is just squelched. KY-196 MOD 13 & above and KY-197 MOD 14 & above, use 12.5 uv. Climax filter adjustment: With 100 uv modulated 30% with 5 KHZ, adjust L-310 for minimum output at the receiver audio output.

Modulation and sidetone adjustments: With .4 @1KHZ input to mic input adjust for 85% modulation. Adjust R-167 (sidetone) for 4 mw into 500 ohm load.

#### SERVICE HINTS: COURTESY OF BENDIX/KING CUSTOMER SERVICE

##### • PART NUMBER INFORMATION:

There are two different styles of power supplies used in the KY-196/KY-197. Therefore Q-114 differs depending on the style used with the unit. If CJ-101 is in the unit, Q-114 should be an X44H564 (KPN 007-00230-0005) When R-236 is installed, Q-114 should be an X44E236 (KPN 007-00381-0002). CJ-101 and R-236 are in the same physical location in the power supply section. There are also two different styles of display boards used in the KY-196/KY-197. Thus, the housings and MHZ/KHZ switches are not interchangeable. The new revision board is most easily identified by the 24 gauge blue wire on the back side of the board. Replacement switch components are as follows:

	<u>New Revision</u>	<u>Old Revision</u>
	<u>12 clicks per rev</u>	<u>8 clicks per rev</u>
Housing	088-00770-0000/0001	088-00765-0000/0001
MHZ/KHZ switches	088-01022-0001	088-00766-0001

When IC's are installed in squelch detector/gate section of the receiver board, I-301 and I-302 should be replaced with a CA-3086 (KPN 120-03029-0000) when defective. Two different styles of T-604 are used in the KY-196/KY-197 transmitters and they are not directly interchangeable. The old style is readily identified by the ferrite cores. The new style has an air core. The part numbers for T-604 are as follows: New style KPN 019-03124-0000, old style KPN 019-03086-0000.

##### • RECEIVER:

The IF AGC voltage at TP-303 with no RF signal should be at least 4.00 vdc.

##### • POWER SUPPLY:

Power supply failures can often be easily located with resistance measurements. Resistance on the secondary of T-102 with respect to ground, are approximately as follows:

+192 volt line	110K
+10 volt line	15K
+9volt line (TP-106)	200
+5 volt line	500
-26 volt line	38K

If the power supply is in current limit (200 ma in receive mode), lift CR-112 to check for a leaky diode. Each diode, (CR-112, CR-113, CR-114, & CR-115) may be lifted to check for possible failures on the lines. WARNING! DO NOT LIFT CR113 & CR114 SIMULTANEOUSLY. DAMAGE TO Q-114 AND T-102 CAN RESULT! The error amp and pulse width can be checked by lifting CJ-101 or R-236 and applying a variable 5vdc to pin 6 of I118. When the cd voltage is >5vdc, the output of I-118 will be either sharp pulses or no output. When pin 6 is <5vdc, the output will be a square wave of either 53 usec or 90 usec, depending on the revision level of the board. If Q-114 fails, it can also damage Q-113 and T-102. It is recommended to replace Q-113 and T-102 when Q114 is defective.

##### • TRANSMITTER:

A failure in the low pass filter can cause RF to be reflected back to the input due to an impedance mismatch. Lift the coupling capacitors off the base of the next stage, connect to a 50 ohm load (watt meter) and check for stage gain.

NOTES:

Weight w/o G/S 4.1 lb., with G/S 4.4 lb.. Tray w/o G/S .7 lb., with G/S .8 lb.. Power 7 watts Com Receiver 1.5 mv for 6 db s+ n/n. Nav Receiver 1.0 uv for 6 db s+ s/n 1.0 uv for full VOR flag. AVC 10-10,000 uv + - 3 db. VOR accuracy 1 degree. G/S sens. 15 uv Audio 10 watts ( 4 ohms ) and 50 mw phones.

Revision No: 1, Dec 1995

← CHASSIS IDENTIFICATION →

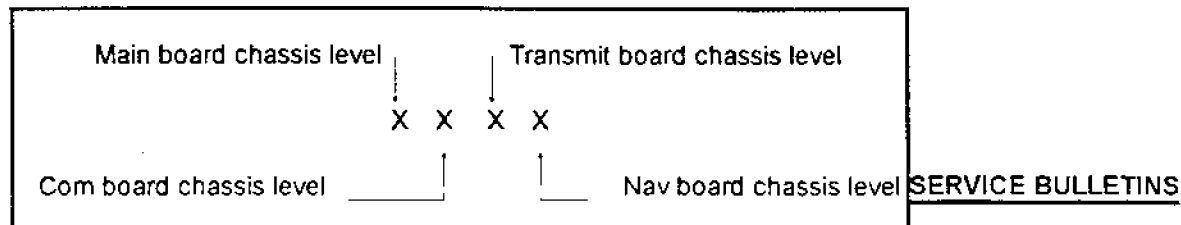

**MK12D-1** Revised . Nav levels A,B,C have P 103-2 & P 103-B internally connected to VREF. There is no connection to P 102-A. Audio is only on P 102-12. Later nav levels have P 103-B, E, F, & 2 all connected to VREF. Also P 102-A is connected to nav audio output at P 102-12 through a 270 ohm resistor.

**MK 12D-2** (applicable to all) Do not parallel speaker output wires or mike audio wires.

**MK 12D-3** (applicable to 14 volt w G/S up to s.n. 50508; 28 volt w G/S up to s.n. 75158, 14 volt w/o G/S up to s.n. 239, 28 volt w/o G/S up to s.n. 25103.) CR 2602 Narco No. 75062-0007 has been replaced by No. 75216-0006.

**MK 12D-4** Modification to "+ nav flag" output (P 103-L) to interface with auto-Pilots.

**MK 12D-5** (applicable to 14 volt w G/S up to s.n. 70052, 28 volt w G/S up to s.n.95010, 14 volt w/o G/S up to s.n. 20081, 28 volt w/o G/S up to s.n. 45021.

**MK 12D-6** (applicable to 14 volt w G/S up to s.n. 52099, 28 volt w G/S up to s.n.75300, 14 volt w/o G/S up to s.n. 01020, 28 volt w/o G/S up to s.n. 25173, also identified as prior to nav chassis level "L"). Erratic VOR operation that sometimes disappears when unit is connected on bench and opened. An uncontrolled VOR drift of 10 to 90 degrees can be experienced. If the OBS is adjusted to compensate for the error, the "TO" flag will be correct. This is not the solution to the problem. This is a ribbon connector problem and is a free repair at Narco. They will also apply a coating on the board. Any other work required when the unit is returned will be charged accordingly.

**MK 12D-7** (applicable up to all F and some G xmtr chassis) FM music through the com receiver. Sometimes this happens when the transmitter is keyed and let up. Q-705 never turns off. It acts as a local oscillator. It has such a wide spectrum that the FM rides right on through. The service bulletin tells you to replace C-710 with a new 150 pf cap. Narco No. 24557-0006. This is a 90% fix, but the 99% fix is to check the old parts layout which was on the linen like paper. (Prior to 1985.) Relocate C-710 as shown in the original pictorial (90 degrees around the corner, across Q-705 Base and Emitter, which is ground), perpendicular to the side rail, and add a 2 pf silver dipped mica across the Collector and Emitter (ground) as shown.

**SERVICE HINTS:**

Courtesy of Jim McNabb (Customer Service Manager) and Jack Vogel (Bench Tech) for Narco Avionics. Display troubles can be confusing. Segment drive is part of the number. Digit drive drives the entire digit. Switching power supplies can be confusing. The manual is very well written and should be used more.

A lot of people are scared of the microprocessor and do not check it properly, they just replace. The most common problem is the power supply. In the manual there is no procedure on how to isolate the power supply for trouble-shooting purposes. A resistor package that simulates the DC load on the 5v, 16v, and 190v line can be used. A problem in the secondary will reflect to the primary and probably shut it down. If you lift some circuits in the secondary while trouble-shooting you can shut down the power supply. By inserting the resistor package in place of the 3 secondary output loads, you can isolate which line has the problem. You can monitor the switching voltage and see when the supply is operating. If you can see the switching when a very low voltage is applied, and it stops as the input voltage is increased, you know you have a saturation problem. With the load installed you can operate the power supply at a normal input voltage and one by one connect the secondary output to see which supply line has the problem. The values for the load are: 5 volt line = 15 ohm @ 10 watts, 16volt line = 125 ohm @ 3 watts, 190 volt line = 19k ohm @ 2 watts. Connect by lifting the fuses out and connect at the power supply side of the transformer.

Garbled or distorted or weak transmitter. (14 volt units) These units use a switch mode regulator to furnish 28 volts for the transmitter modulation. U3701 is the modulator IC. Pin 14 input should be 24-27 volts. Pin 1 should be 1/2 of that. Techs too often change Q3701 & Q3702 which are the current supplies for this IC. If the B regulator is good giving the 28 volts, and 1 of these transistors is open, you won't have the 14 volt swing to ground on the output. Check the B regulator first then check the distribution on the IC. If you have less than 50% divide from pin 14 to pin 1 the device is bad. If the voltage still is collapsing, as when you key the transmitter, you have around 2 volts, instead of the normal 7 volts, in all probability Q3701 is bad. (or possibly Q3702) These devices actually supply the current to the transmitter. The IC U3701 just supplies the AC modulation.

There are 2 sets of schematics out on the MK 12D. The second one has been out since 1985. The new ones are paper whereas the old ones were the linen like paper that you can not tear.

There was a change in the distribution of the 190 volt line that drives the display. The display is multiplex. Both anode and cathode dividers are controlled by the microprocessor. There are no more than 2 segments on at any given time for around 2 milliseconds. For instance, the number 1 and number 9 (which is the active 1/100 mhz, and the 1/10 mhz, on the com and nav). From then on, every other one of the segments come on in turn. There may be 2 numbers out, but if they are either in the active windows or the standby windows of both the nav and com, usually 1 IC will be bad which controls the anode portion. If the number out is in either the nav or the com, usually an IC will be bad which controls the cathode portion. A change was made in the type of device used for U2101, which was a 6184. It was changed to a 6184A-1. Later the circuit was re-designed using a ULN6510. The first two is not interchangeable with the last one. One device works on 90 volts and one works on 190 volts. If the wrong device is installed, the unit will not work at all. ***Make certain you are working with the correct schematic!*** Wrong ones have been installed.

Justify why you are changing the part. Look at the levels. Try to confirm the problem by digital, analog or analytic methods. If you have reasonable doubt of the validity of the part, change it. In most cases it will save you time in the long run. Often techs will change many parts to save time, but the wear and tear on the board, and the expense of the parts take their toll.

NOTES:

## The Technicians Notebook

By Jerry Gordon

# NAV-11/12

**Weight:** NAV-11 2lb, 8 oz. NAV-12 3lb, 4 oz.

**Sensitivity:** 1.5 uv Nominal /2.0 uv Max for 6 db S+ N/N ratio.

**AVC:** 4 db mMax from 10uv to 10K uv.

**Audio output:** 30 mw into 300 ohms.

**Omni accuracy:** 2 degrees nominal.

Revision No: 1 Dec 1995

Following is courtesy of Don Snyder, Field Service Assistant Manager, Narco Avionics.

Before spending too much time on a NAV-11 or NAV-12, Check parts that no longer are available. Also check the very expensive parts. Next check the parts that will take large labor time to replace.

NAV-12 meters are no longer available. If you find the slightest problem with a NAV-12 meter, STOP! Tell the customer it's unrepairable. NAV-11 meters are available under Narco PN 030880507 and are very expensive. Call for latest price.

The cluster gear for the fractional Mhz is no longer available. If the Khz shaft does not turn, yet the odometer does, suspect the cluster gear to be broken. Return the unit unserviceable to the customer.

Many times the belt that works the Mhz channeling breaks. The belts are available under Narco PN 549600001. Most technicians that change belts may assemble the mechanics improperly. Remember that every part in this radio is absolutely necessary. They wouldn't be in there if this wasn't so. While changing a broken belt, you should check the HFO. This HFO will probably have three or four bad crystals. The average cost of crystals are over \$55.00 each. While the front end is apart for belt replacement, carefully turn the unit on while monitoring the frequency of the oscillator and turn the Mhz shaft. Check each crystal for proper frequency. Note the dead crystals or out of tolerance crystals. The customer may be unaware of defective channels because of no use in the flying area; however, all frequencies must function. Most HFO's become intermittent with long term use and should be inspected thoroughly. The ground side of C-109, (100 pf cap) should always be re soldered to make a good RF connection. This is vital.

The HFO and LFO can be run on the bench by themselves. Just hook up 10 volts A+ and a ground to your bench power supply and check the oscillator operation with a frequency counter. Fix everything before reinstalling the LFO and HFO.

Before working on an HFO, study the removal operation that will be necessary. Completely remove the Khz gear and shafts. One is metal and the other is phenolic. Loosen the one set screw holding the Mhz shaft and pull it to the back butting against the tuning wafer. Do what is logically left to do, to remove the HFO or the LFO.

U-201 is another part that is not available. Be careful you don't short the metal hat to ground or you will blow it out. The DC balance pot, (R-245) must always be mechanically centered and left that way forever. If the needle is not DC balanced with this pot mechanically centered then there is a problem in another area.

One last comment; The receiver of the NAV-11 and NAV 12 should have a strip of insulation between the board and the fingers on the VOR zero set pot and the LOC zero set pot that are mounted on the rear of the unit. If it is missing it will cause a pinned L/R needle intermittently.

# The Technicians Notebook

By Jerry Gordon

# NAV-121/122/124

Revision No: 1 4/1995

Nav 121 Nav, Loc, Nav 122 Nav, Loc, GS, Marker

Nav 122A Nav, Loc, Marker, GS meter only.

Weight: Nav 121-2.5 lb., Nav 122-3.0 lb., Nav 122A-2.9 lb..

Sensitivity: 1.0 uv for 6db S+ N/N Full omni flag 1.0 uv.

AVC 10 uv-10 Kuv = 1.0 db max. Audio output: 50 mw into 500 ohms.

VOR accuracy = 2.7 degrees. LOC accuracy = -5ua. DME/GS channeling 2/5.

Marker 200 uv HI sens for lights, 1000 uv LOW sens for lights. Audio 8 mw into 200 ohms. GS 20 uv full flag.

**SERVICE BULLETINS:** The most important bulletins are listed here in detail. Others can be looked up if applicable.

**SB-1** (Applicable Nav 121, 122 & 124) Matched resistors on Omni-Localizer P.C. Board. Matched resistors have been added to the Omni/Localizer board to improve reciprocal error and D.C. centering. Resistors may be matched or ordered as matched pairs.

1. (R-665 & R-667) & (R-658 & R-659) part number 01235-1312 must be within 1% of 26.1K ohm and within 50 ohms of each other.

2. (R-656 & R-651) part number 01235-1314 must be within 1% of 75K ohm and within 150 ohms of each other.

Get rid of the tan colored resistors. Replace with good 1% resistors.

**SB-2** Nav-122 Glide slope Indicator.

**SB-3** Nav-121/122 Maintenance Manual Update.

**SB-4** Coupling Auto pilots to Nav-122/124 Series NAV units.

**SB-5** Nav-124/124A/124R Maintenance Manual Update.

**SB-6** (Applicable Nav-121/122/122A/ID-124) Improvement in OBS Gear Assembly (Nav Receiver)

Because of the cold weather over a large portion of the US, in a small number of CENTERLINE NAVS, the OBS potentiometer and the OBS azimuth card may have gone out of synchronism because of a slippage between the small gear on the OBS shaft and the large gear on the OBS card. This creates an error in the OBS course display. This slippage may be obvious with the course azimuth card not turning at all when the OBS knob is rotated or it may be subtle, slipping only occasionally and apparent to the pilot only when the OBS setting on two NAV's channeled to the same VOR are compared, or when switching from a VOR behind the airplane to a VOR ahead.

The original OBS card was a 2 degree card and gave problems with teeth breaking or skipping. Narco changed to a 5 degree OBS card (kit 03723-0506) which is a good solid fix.

**SB-7** Manual additions.

**SB-8** (Applicable Nav121/122) Production change on Omni/Loc plug J-806.

In all Nav 121/122/122A's, flexible circuit VOR/LOC connector J-806 should be being floating. This modification enables J-806 to move slightly in response to VOR/LOC circuit board flexing caused by vibration or turbulence. Connector to circuit board contact is now improved and NAV reliability is further increased. On some chassis, J-806 is floated by backing off the two screws that normally hold the connector. On other chassis the connector is threaded and the mounting screw is installed from below with a nylon spacer to support the board. DO NOT TIGHTEN these fastenings. The current chassis level ADAAD will remain the same and a letter "M" will be stamped near the chassis number to denote this modification. This is part of the in house "M" mod which includes a gold NAV board plug. Narco flashes the card edge on VOR boards with gold. Intermittent

VOR/LOC operation is usually done away with by the "M" Mod. This mod can only be done at the factory service center. The main thrust of the mod is the gold plug and the gold flashed card edge of the VOR/LOC board.

**SB-9** Center line 121/124 NAV signal output.

**SB-9E** Nav121/122/124 Series radios operating on ASB doppler VOR stations.

**SB-10** Design change.

**SB-11** VOR needle wandering as a result of improper AGC action.

It has been found that some receiver modules in the NAV 121/122/124 display improper AGC action. This can result in a wandering VOR needle (+ 2degrees) during reception of strong signals. This is a result of the receiver I.F. stages lacking adequate AGC control and the R.F. AGC overcompensating. Monitor J-801 pin 16 (Nav 121,122) or J-1006 pin 8 (Nav124) with a high impedance AC meter. With standard VOR signal at 2uv, increase to 20kuv. If indication on meter is greater than 3 db, change the value of R277. If this does not correct problem, select R251 to complete the AGC adjustment. If 10uv signal input does not give at least 25 S/N at 50 mw, re-check previous steps.

**SB-12** Localizer centering.

**SB-13** Defective connector.

**SB-14** TSO of glide slope receiver.

**SB-15** Nav 124 Failure of latching mechanism to lock radio. The wrong thickness washer was installed at the factory on some units. It is the washer on the front of the locking pawl. It should be .020 thick. The wrong one was .062 thick. If you find an intermittent radio when installed in the aircraft, replace this washer. Narco PN 81307-0099.

**SB-16** No service bulletin issued.

**SB-17** Oscillation in U-2095 on the receiver board and U-604 on the omni/loc board due to the characteristics of some of these devices. If U-205 or U-604 is replaced in the normal course of repair, change the value of the input capacitor C-260 for U-205 or C-613 for U-604 with a .56 uf @100v, Narco PN 24550-0564. It is also VERY IMPORTANT for a diode to be across the regulator to prevent oscillation. The diode is CR-216 on U-205 and CR-619 on U-604. The diode is a silicon 1 amp or better, Narco PN 75062-0005. Installation is cathode on the input and anode on the output.

**SB-18** Revision "G" Omni Localizer boards used in current Nav-121/122's.

Technicians should note: The Nav-122 Glide Slope needle will stow UP on VOR frequencies. On ILS frequencies the needle centers and the audio will shut off. The volume knob must be pulled out to hear any audio.

**INFORMATION COURTESY OF DON SNYDER, FIELD SERVICE ASSISTANT MANAGER, NARCO**

**NOTES:**



# The Technicians Notebook

By Jerry Gordon

# R-346A/R546E

Weight including mounting 3.8 lbs. Indicator 1.0 lbs.  
Loop (L-346A) 1.6 lbs. (doubler .18lbs.)  
Sensitivity - ADF: < 50 uv/m for max. 3 degrees bearing error.  
REC: < 50 uv/m for 6db S+ N/N @1khz mod 30%.  
Audio output: 100 mw @500 ohms.

Revision No. 2 Aug. 1995

## ARC FIELD ENGINEERING SERVICE BULLETINS:

**170: (4/16/74) R-546A/346A** Installations in Cessna single-engine aircraft only. RF filter to prevent spurious re-radiation of VHF Com and FM broadcast transmissions by the ADF sense antenna. Pilot is notified he is transmitting on other frequencies or he may be receiving FM broadcast in the Com receiver. A low-pass RF filter (P.N. 43718) is installed in line with the ADF sense antenna. This unit is not installed if the ADF installation currently contains an RF signal limiter (P.N. 4137600000). This limiter, if installed will be connected directly to the sense antenna connector at the rear of the ADF mounting rack. Check service bulletin for details.

**179: (2/19/75)** Modification to prevent jamming of the IN-3246A/B ADF indicator rotatable dial. If this has been performed, it should have a sticker on the indicator with the following: FESB # 179. At the time of this bulletin, the FES kit for performing the Mod was free. If you encounter this problem, check the bulletin.

**ARC SERVICE ADVISORY BULLETIN # 37. (2/7/73)** Low temperature operation. Applicable to Mod level below Mod 1. If you find a radio before Mod 1, check this bulletin.

**ARC TECH AID # 7 (7/22/75)** 1. Post installation adjustments. Do not adjust unless the installed ADF system does not meet the performance specifications in the manual. If necessary to adjust, clockwise adjustment of the LOOP GAIN SET will increase ADF range and increase pointer jitter. Clockwise adjustment of the SERVO GAIN SET will decrease homing time and increase pointer jitter even to the point of pointer oscillation.

2. **FESB # 179** addressed dial jamming in the IN-346A/B indicators. If the idler gear post has been loosened from its mounting, the indicator should be returned to the factory for repair.

## AVIONICS SERVICE LETTERS:

**AV76-3 (2/6/76)** 1. Antenna coupler relocation on 1976 Cessna 172 S.N. through 17265685 thru 1726592 and 17265694 thru 17265995. This should have been done on all applicable aircraft.

2. Tech Aids # 12 and # 13 covering errors in the service manuals.

**AV76-7 (6/7/76)** 1. N/A ADF 2. More manual corrections.

**AV76-9 (10/8/76)** More manual corrections.

**AV77-6 (3/7/77)** ADF circuit board exchange program. The A1, A2, and A7 boards contain a matched set of 8 varactor diodes. The varactors are selected and matched. All three boards are serialized with a common serial number. The three boards should always be installed as a matched set and never mixed with other serialized sets of boards. The varactors are not available to the field. The three boards must be exchanged. The part number of a set is 6136300000R, except for the R-846A which is 6137200000R. The "R" is for a rebuilt set.

**AV78-27 (8/21/78)** Authorization for using the R-346A service manual if working on an IN-346 as part of an R-546E installation.

**AV79-4 (1/29/79)** Noise reduction in 1979 model aircraft with RA-446A and RA-846A installed.

**AV80-14 (4/14/80)** Volume control circuit noise reduction. Reduction of scratchy noise when the volume control is adjusted. Accomplished by adding a filter circuit consisting of a .47uf cap P.N. 40248-1059 and a 4.7k resistor P.N. 20000472.

**Part Numbers - Knobs:** Small 3984111240, Large 4041800000

## SERVICE HINTS:

Courtesy of Steve Hanoka, Director of Customer Service with Sigma-tek

## COMMON VARACTOR PROBLEMS:

1. Excessive noise due to leakage which is indicated by low sensitivity across the spectrum.

2. Mismatching of varactor characteristics due to normal aging, which is indicated by low sensitivity at spot frequencies poor compass operation at spot frequencies. After all other possibilities are exhausted the varactors are checked by aligning the high band. A minimum signal to noise ratio of 16db at 70 mv @30% modulation should be achievable across the band. Also there should be no sharp drops in modulation percentages across the band.

#### **INDICATOR 180 DEGREES OUT:**

The only known cause specific to this problem is detuning of the A1 tuning transformers (A1T1, A1T2, A1T3). With my experience, this problem is most common on the low band.

#### **WEAK RECEIVER:**

1. **Poor sensitivity.** Several things commonly cause poor sensitivity.

A. A weak RF amp which can be checked with voltage measurements. At the junction of A2Q3 and A2C27 the voltage should be approximately 2.8 volts and at the junction of A2Q8 and A2R24 the voltage should be approximately 3.2 volts.

B. A weak mixer which can be checked with voltage measurements. At the junction of A2Q13 and A2L7 the voltage should be approximately 2.2 volts and at the junction of A2Q13 and A2R38 the voltage should be approximately 2.0 volts. The voltage at R38 should be lower than the voltage at L7.

C. A weak 2nd. IF amp, which is checked with voltage measurements at pins 5 and 6 of A3U1. The voltage should be .19 volts, and at pin 12 the voltage should be .23 volts.

D. The band switching diodes will cause low sensitivity on either the mid or high bands or both. These are also checked with voltage measurements. With the receiver set at 700 khz. the voltage at the cathode of A2CR3 should be less than 40mv, and at the cathode of A2CR4 the voltage should be greater than 9.2 volts. With the receiver at 800khz the cathode voltage of A2CR3 is greater than 9.2 volts and the cathode voltage of A2CR4 is less than 40 mv. The bypass caps A2C14, A2C15, A2C20, A2C24, A2C28, A2C37, A2C39, A2C42, A2C43, and A2C54 also cause poor receiver operation due to leakage. The most common are A2C14, A2C15, A2C20, A2C24, A2C41, and A2C43. A2C14 is checked at the sense antenna input. On the low band there should be no DC voltage at this point. C15 is checked at the junction of A2R13 and A2R14. On mid and high bands this voltage should be less than 1volt, and on the low band this voltage should be greater than 7 volts. A2C20 and A2C24 are checked while testing band switching diodes. A slight decrease from the 9.2 volt reading indicates a leaking cap. A2C37, A2C39, A2C52, and A2C54 are checked by setting the receiver off their respective bands and checking the voltage at the junction of the cap and its switching transistor. This voltage should be 8.9 volts. A2C28, A2C41, and A2C43 are checked by setting the tuning voltage at 1.55 volts and checking varactor cathode voltages. The cathode voltage of A2CR9 and A2CR10 should be equal and normally run from 1.53 to 1.54 volts. The cathode voltage of A2CR5 normally runs from 1.51 to 1.52 volts.

#### **2. WEAK COMPASS OPERATION**

A. Low modulation is commonly caused by three things. A bad loop amp (A1Q3), capacitor leakage in A1C12 and A1C13, and loop amp A1Q3. J309 type have a higher gain than MEM-655. Modulation procedures normally exceed 60% across the spectrum.

B. Modulation distortion commonly caused by modulator bias resistors A2R5 thru A2R10. These are checked with the sense antenna disconnected and the compass at 90 degrees. With A2R12 adjust for balanced peaks. All the peaks should be rounded.

C. Maladjustment of the servo amp is checked by setting receiver at 950 khz and the signal generator at 950 khz (1000mv unmodulated). A4R9 is adjusted for indication with a signal input of 50mv at the same frequency.

D. Weak Low Band. The low band is normally weaker than the mid and high bands (common low band and signal to noise ratios of 13 to 17db, common mid and high band signal to noise ratios of 16 to 17db) So any low band sensitivity problems appear across the entire spectrum.

# The Technicians Notebook

By Jerry Gordon

# R-402A

Weight: .7 lbs.

Low sens: 200 uv, High sens: 1000 uv

Audio: 50 mw into 600 ohm load.

14V unit P/N: 42410-5014 or 5114

28V unit P/N: 42410-5028 or 5128

5014 & 5028 included threaded inserts for mounting, 5114 & 5128 include only mounting holes.

Revision No: 1 11/1995

## SERVICE INFORMATION LETTERS:

**AV80-30** : Tech Aid No. 111. Changes made in the R-402A Marker including replacement of the filter assembly, capacitor change to improve reliability, and a schematic diagram update.

**A:** Beginning with sn19,790 crystal filter assy A2A1 P/N 42905-0000 is replaced with A2FL1 P/N 49755-0000. The new filter is not adjustable or repairable. On the new unit, the antenna connector is separate P/N 28391-0000. Retrofit of earlier units is not recommended.

**B:** Beginning with sn19,587, capacitor A3C8 is changed from P/N 40248-1166 (22uf @15V) to P/N 40248-1375 (22uf @35V). It may be replaced in earlier units for product improvement. Bend the positive lead to fit and secure the capacitor with RTV as shown in the drawing.

**C:** Changes in the unit are as follows:

1: A2C19, A2C20, A2C21 changed to 33pf P/N 27698-0330

for better tuning and to increase audio gain.

2. The following changes were made to improve keying at high input levels:

A2C15, A2R14, and A2R22 were deleted. A2CR7 (ARC P/N 31293-0000) and A2R68 (ARC P/N 200-0183) were added. A2CR1, A2CR2, and A2R15 were connected and the polarity of A2C13 was reversed.

Value changes were: A2C14 to 100uf, A2R1 to 22 ohms, A2R16 to 22,000 ohms, A2R17 to 3,900 ohms, A2R19 to 2,200 ohms, A2R20 to 100 ohms, A2R21 to 12,000 ohms, A2R46 to 5,600 ohms, A2R49 to 8,200 ohms, A2R54 to 2,700 ohms.

3. The following changes were made to reduce circuit oscillation: A2R30, A2R7, and A2R9 were directly replaced, respectively, with 4.7uh choke coils A2L10, A2L8, and A2L9.

Choke Coil A2L1 was deleted and resistor A2R25 was reconnected. The value of A4R1 was changed to 39 ohms in 14V units and to 180 ohms in 28V units. Value of A4R2 was changed to 10 ohms in 14V units. Beginning with sn1,555, A4R2 was deleted in 14V units and replaced with a jumper wire to increase light brilliance. Caps A4C1, 33uf (P/N38269-1603), diode A4CR1, Type 1N4740 (P/N 35954-1100), and A4R3, 56 ohms (P/N 32395-0560, in 14V units; 220 ohms, P/N 32395-0221, in 28V units) were added.

4. A2R34 changed to 39k and A2R36, A2R37 changed to 10k to stabilize receiver sensitivity threshold. In later units, A2R34 was changed to 36k to prevent false lighting.

5. A2C26 changed to .22uf and A2R54 to 3.9k to eliminate false lighting. In later units A2R54 was changed to a selected value, and A2Q2 was changed to type MPSH07 (P/N 41123-0054) to increase gain and correct timing.

6. A2R43 changed to 27k to correct false light indication at threshold on turn-off.

7. A2Q1 & A2Q2 changed to type MPSH07 and A2CR1 & A2CR2 were changed to type FH-1100 (P/N/ 42144-0000) to increase receiver sensitivity.

8. A3R17 changed to 4.7k and A3R24 changed to 2.7k to decrease 400hz distortion and increase audio output.

9. Varistor A4RV1 type 47Z1 (P/N 45553-0003) added to reduce effects of power line transients.

10. Beginning with sn 16,125 A2C32 (.0015uf, P/N 28448-0152) was added and A3R3 was changed to a selected value to adjust pulse width and increased filtering of the audio output.



11. Beginning with sn 19,790 A2A1 was deleted and replaced with filter A2FL1, (P/N 49755-0000) and connector A4J1 (P/N 28391-0000).

AV81-1 Tech Aid no 125. Improvement to the audio amplifier circuit. Replace A3R15 from 1.8k to 1.5k. A3R23 changed from 47 ohms to 36 ohms. A3R22 changed in 28 volt units from 15k to 20k.

**PART NUMBERS:**

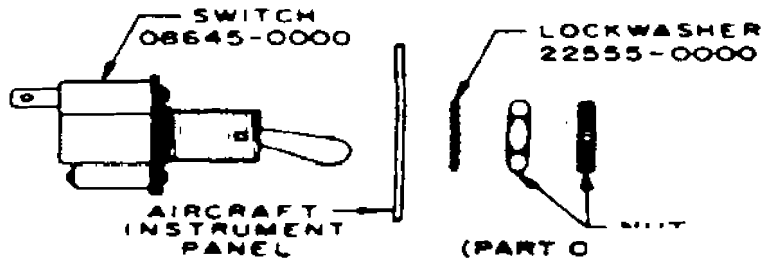
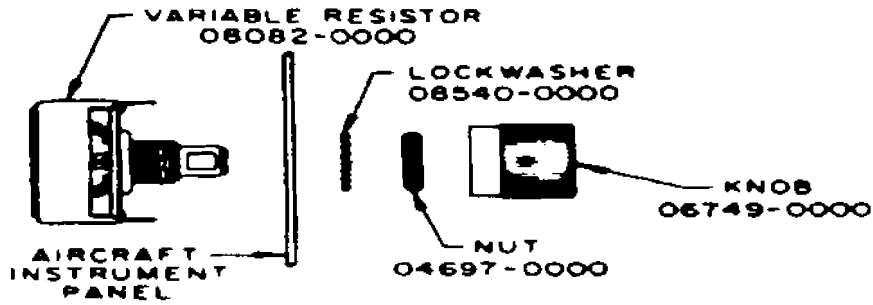

**NOTES:**

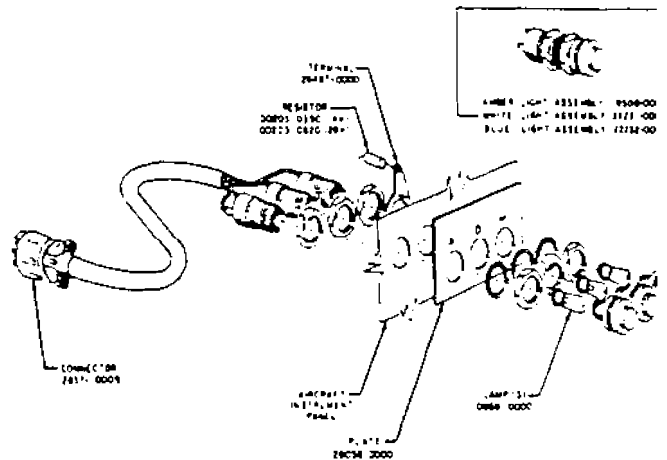

# The Technicians Notebook

By Jerry Gordon

# R-443B

Weight: 2.0 lbs. 36450 mounting (Solid) .3 lbs. 36280 mounting (Shockmount) .6 lbs

Channeling: 2 out of 5, 40 channels.

Revision No: 1 12/1995

Sensitivity: 40uv maximum for 47ua deflection and 250ua flag current.

Output: Deviation, 3 ea. 1000 ohm, 150ua pointers. 3 ea. 1000 ohm, 250ua flag circuits.

**AV80-28 Tech Aid No 112.** Change to improve deflection linearity. Some glide slope receivers are subjected to wide temperature variations in their operating environment. A change has been introduced in current production receivers to improve glide slope deflection linearity over the temperature range. This is accomplished by changing resistor values in the converter to lower the "Q" of the 90hz/150hz filter circuits. It will be incorporated in future production R-443B receivers. Retrofit of earlier units should not be required.

The improvement consists of value changes for the twelve resistors listed in the chart below, and the deletion of variable resistors A2R12 and A2R16. To close the circuits left open by the removal of the variable resistors, resistor A2R13 is reconnected to the junction of A2C2 and A2C4, and A2R17 is reconnected to the junction of A2C3 and A2C5.

Resistor	Original	New
A1R83	200	180
A2R3	3,3k	4.7k
A2R4	910	1.5k
A2R7	500	2k
A2R8	2,430	3,240
A2R9	910	1,910
A2R10	91k	90,900
A2R11	121k	80.6k
A2R13	332	1,070
A2R14	100k 10%	100k 1%
A2R15	56,200	47.5k
A2R17	267	649

When a glide slope with this change incorporated is to be bench tested and adjusted, delete all adjustments references for A2R12 and A2R16.

**SERVICE BULLETIN No 192.** Applicable to sn 6144 and below. This is "Mod 1" It is to be performed when glide slope is lost but can be restored when rechanneled. Parts required: Kit P/N 61390-0000. If you find one this old that needs the mod request the Service Bulletin from Sigma-Tek.

**AV80-41 Tech Aid No 124.** Incorporation of new converter assembly which improves deflection linearity over the operating temperature range. Beginning with sn 21,650 this is "Mod 2". Resistor A1R81 is changed to 12k and A1R83 is changed to 220 ohms. Unless the replacement of the entire A2 assembly is necessary, retrofit of earlier receivers is not recommended. Adjustments for "Mod 2" units is as follows: The 10 volt adjustment is now A2R45.

**Step 1.** Turn on equipment and select operating frequency of 109.30 mhz.

**Step 2.** Set signal generator for output of 700 uv at 332.00 mhz, with tone ratio control set to 0.

**Step 3.** Adjust A2R6 for 0 ua indication (centered) on glide slope pointer meter M1.

**Step 4.** Set signal generator tone ratio control to 2 db, 90 hz predominant: adjust A2R1 for indication of + 78 ua on M1 (deflection to the right), watching for overload. (Overload occurs when glide slope pointer deflection reaches maximum then decreases while A2R1 is being adjusted.)

**Step 5.** Repeat steps 3 and 4 until no further improvement of centering and deflection sensitivity can be accomplished.

**Step 6.** Set signal generator tone ratio control to 2 db, 150 hz predominant: M1 should indicate -78 ua (deflection to the left).

**Step 7.** Set the signal generator tone ratio control for 90 hz predominant, and adjust level for 55 ua deflection of M1.

**Step 8.** Adjust A2R27 for an indication of greater than 750 ua on flag current meter (M2).

**Step 9.** Readjust A2R27 until M2 just ceases to indicate. Flag current on M2 should be less than 750 ua.

**Step 10.** Increase signal generator level to produce a standard deviation output of 60 ua on M1. Check that flag current on M2 is greater than 750 ua.

**AV82-1 Tech Aid No 146.** Modification to improve deflection response. "Mod 3". Beginning with sn 23,925 this change consists of changing 2 filter capacitors, A2C5 and A2C6 to 6.8uv @35v P/N 41955-4685. This may be incorporated in any Mod 2 unit that includes converter Assy A2, P/N 50811-XXXX.

**AV82-10 Tech Aid No 142.** Second oscillator improvement. Beginning with sn 23,410. See the new schematic. Since the new circuit has a variable component, it can be adjusted. The second oscillator is adjusted as follows: Set to 109.3/332.0 mhz. Connect an RF voltmeter to junction of A1R70 and A1C45. Adjust A1C49 for max indication on the RF voltmeter. Record indication. Adjust A1C49 toward min until the indication decreases to 10% less than max. Set frequency to 109.35/332.15 mhz and verify the other crystal is oscillating.

**AV82-18 Service Bulletin No 102.** Changes to prevent sensivity loss at low ILS frequencies. Parts required: 1ea. RF coil, 1uh P/N 35637-9101 and 1 ea. resistor, 18 ohms 5% 1/4 w P/N 00341-0180.

On the flow solder side of Assy A1, cut the + 10 volt bus trace in 2 places, as shown, being careful not to isolate A1R7, C56, and C42. Install protective sleeving on the 1uh coil. On the flow solder side of A1, solder one end of the coil to the + 10 volt bus at A1R62 & R66. Solder the other end to the + 10 volt bus at the approximate location shown, to bridge the gap in the + 10 volt bus caused by the cuts in the printed wiring. Remove and discard original resistor A1R80 (33 ohms). Solder the new 18 ohm resistor in its place. Verify proper operation of the receiver.

**FOLLOWING COURTESY OF JOEL NOAL, SIGMA-TEK**

1. Failed unit works on 14V input but not 28 volts. Solution: VR3 IN4734 A2 sn 21599 & earlier.
2. Loss of every other channel. Solution: Y21 or Y22.
3. Individual frequency loss. Solution: Crystal corresponding to frequency Y1-Y20.

**NOTES:**

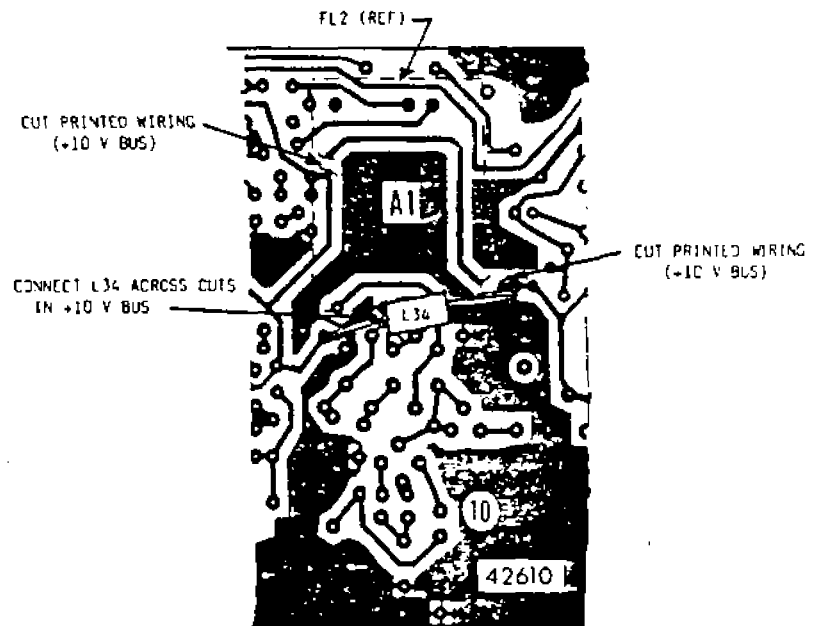
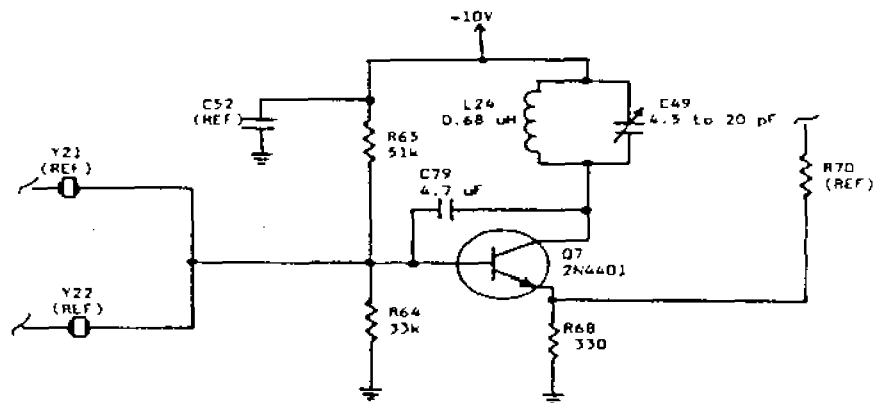

# The Technicians Notebook

By Jerry Gordon

# RT-308/328

Revision No: 2 2/94

Weight: 7.3 lbs including mount.

Com receiver sens. 1.5 uv for 6db s+ n/n Nav receiver sens. 1.5 uv 6db

AGC 8 db 10 to 20,000 uv

AGC 8 db 10 to 20,000 uv

Audio output 100 mw 250 ohms

Audio output 100 mw 250 ohms

Transmitter 7 watts, 85% modulation

VOR accuracy + - 3 degrees

Speaker audio 8 watts 4 ohms

## AVIONICS SERVICE LETTERS:

**AV-74-2** A1C155 Replaced with p.n. 40248-2213 if it is black. (15mfd. @20vdc).

**AV-74-10** Lithium battery powered ELT (with shorter antenna C589510-0201).

**AV-74-12** Service Bulletin # 173 (RT-328A), (Also see SB# 162 for RT-308C/RT-328C) Improved squelch operation. (Noise reduction).

**AV-74-18** Reduction of FM radio interference on 1971 through 1974 Cessna's. Component change per SB# 156A and SB# 164A supplement.

**AV-75-3** Service Bulletin # 178 (1971 through 1975 Cessna's) Product improvement to reduce "birdies" on 124.025 and 135.3 mhz. Parts required: Kit p.n. 61374-0000 Time required 1 hour

**AV-77-11** Update on RT-308C, RT-328C, RT-328D, RT-328T

**VOR ADJUSTING:** (According to this service letter).

1. Set A8R41 to center through front panel.

2. VOR input standard 100uv. 0 degrees "TO". Indicator 0 degrees.

3. Adjust A1R84 for 2VRMS at A1TP-V.

4. Adjust A1R127 for 3.5VRMS + -.3VRMS at A1TP-R.

5. Capacitors are selected to make the course error + -5 ua for 0 degrees and 180 degrees courses. A1C101 is selected for symmetrical error and A1C117 to zero this error.

6. Hold test switch to "T" position. If deviation is to the right, adjust A1R132 for 0 ua + -10ua deviation. Then adjust A1R88 for 0 ua + -5 ua deflection. If deviation is to the left, adjust A1R88 for 0 + -10 ua deviation. Then adjust A1R132 for 0 ua + -5ua deviation. Release "T" switch. (NOTE: for the RT-308C which has no test switch, connect a 180k resistor and a .003uf capacitor in series between A1-3 and A1-32. (Newer board pins 20 and 29) Set generator for 9960FM modulation only. After adjusting remove the resistor and capacitor.) **COURSE WIDTH ADJUSTMENT:** Standard VOR input (100uv 90 degrees TO, set course indicator to 100 degrees. Check voltage at A1TP-R for 3.5vrms + -.3v. Adjust A1R84 (Var Level) for 5 dots (150 ua + -.03ua).

**AV-78-36** Synthesizer Specifications.

**AV-79-7** Nav/Com assembly A1 parts difference.

**Part Numbers:** Relays, K1 39953-0001 K2 39957-0012 On/Off Vol Control 40178-0001 Lock Pawl 29324-0000

A4Q1 (2N6101) 41123-0036 A4Q2/3(D44H8) 41123-0047 Belts (Long, Com & Nav khz) 39839-0053 (Nav mhz) 39839-0044

Pulley Gears (Com & Nav khz) 39489-0000 Set Screw (3/48 x 1/8) 303-0008 Pulley Gear (Nav mhz) 39493-0000 Set Screw (3/48

x 1/8) 303-0008 Knobs (Freq) 40418-0000 Set Screws (8/32 x 3/16) 324-8012 (Vol/Sq) 39841-1025 Set Screws (4/40 x 1/8)

324-4008. IC Sockets 8 pin 40176-0008 12 pin 40176-0012 Power Supply for RT-328T 42409-0000

## SERVICE HINTS:

After changing frequency drive belts, align the frequency window by loosening the set screws on the belt drive gear on the frequency selector shafts. With a signal generator or a frequency counter determine the frequency the radio is on and rotate the belt drive gear to the proper position. Tighten the set screws. If the radio acquires a chronic intermittent VOR problem and it has the converter IC's mounted in sockets, Replace the sockets. For a permanent fix, remove the sockets and solder the IC's directly to the circuit board. Com output from synthesizer is antenna frequency + 10.775 mhz

Nav output from synthesizer is antenna frequency -16.025mhz (110mhz= 93.975mhz)

## TIPS AND ADVICE: Courtesy of Sigma-Tek

**Power supply:** A3 Power supply output has to be loaded to trouble-shoot properly. The 38 volt and the 5.1 must have a resistive load or the load of the circuit or the 38 volts will go high and the 5.1 volts will not be present. The load resistors should be 3.8K (1/2 w) for the 38 volt line and 620 ohm for the 5.1 volt line. The selectable resistor (R3, for setting the 5.1 volt line) should be around 220K to set the 5.1 volt output. On the input of T2 look for a 13.5 volt square wave. Check for open

or shorted winding on the transformer.

**A4 Speaker Amp/Modulator Board:** Most common problem are the resistors R3 and R4 (.33 ohm) in the emitter circuits of Q2 and Q3. They should be matched in value. If you replace the transistors, replace the resistors!

**RECEIVER:**

The IC's can be swapped for trouble-shooting. For excessive noise in the receiver check for loose antenna connections and synthesizer connections.

**SYNTHESIZER:**

Exchange or repair yourself as required. AV-78-36 has all the information regarding the 41405 synthesizer.

**CONVERTER:**

Transformers T3 and T4 are the most common problem here, with T3 failing ore often. C-95 and C3 are usually the cause of phasing errors of 10 to 30 degrees. The Variable 30 hz amplifier can cause errors also and would be the best place to look for that type of problem. TO -

FROM or LEFT - RIGHT problems are usually the balancing capacitors between these 2 lines. (C-176 & C-177)

U10 (NC1469R) Regulator for the 8.5 volt line is no longer available. The replacement will be a direct plug in but will be a different component.

**TRANSMITTER:**

The most common problem is the T/R relay. Re-alignment of the transmitter by adjusting C9 and C10 may be needed. One deals with the lower frequencies and one deals with the higher frequencies.

**COM FREQUENCY COUNTER:**

The 360 channel counter assembly is no longer available. The most common problem with these counters are the tabs breaking. The 720 channel counter assembly is the same except for the barrel with the numbers. To replace broken parts on the Com counter, buy a Nav counter and use the parts from it as required. The Com barrel with the numbers is usually not defective. When the newer style A1 board was implemented, the notification was by service bulletin, with the new layout and the adjustments. The parts list was not added at that time and the part numbers are different. The parts list for the new A1 board are in AV-79-7.

**TUNING VOLTAGES**

NAV J2 PIN 18	COM J1 PIN3	VOLTAGES
108 3.5	118 3.5	5.1 J1-0, J2-9
110 4.9	123 6.2	8.5 J1 17, J2-2
112 7.7	128 10.5	24 J1-7, J2-15
114 11.3	133 17.2	4.5 J1-4 (REC)
117 19.4	135 21.0	
117.95 23.0	135.95 23.0	

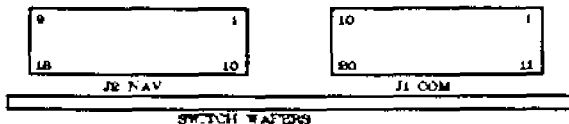

**LOCALIZER ADJUSTMENTS**



- 28 FLAG
- 23 SELF TEST
- 19 CENTER
- 3 DEFLECTION



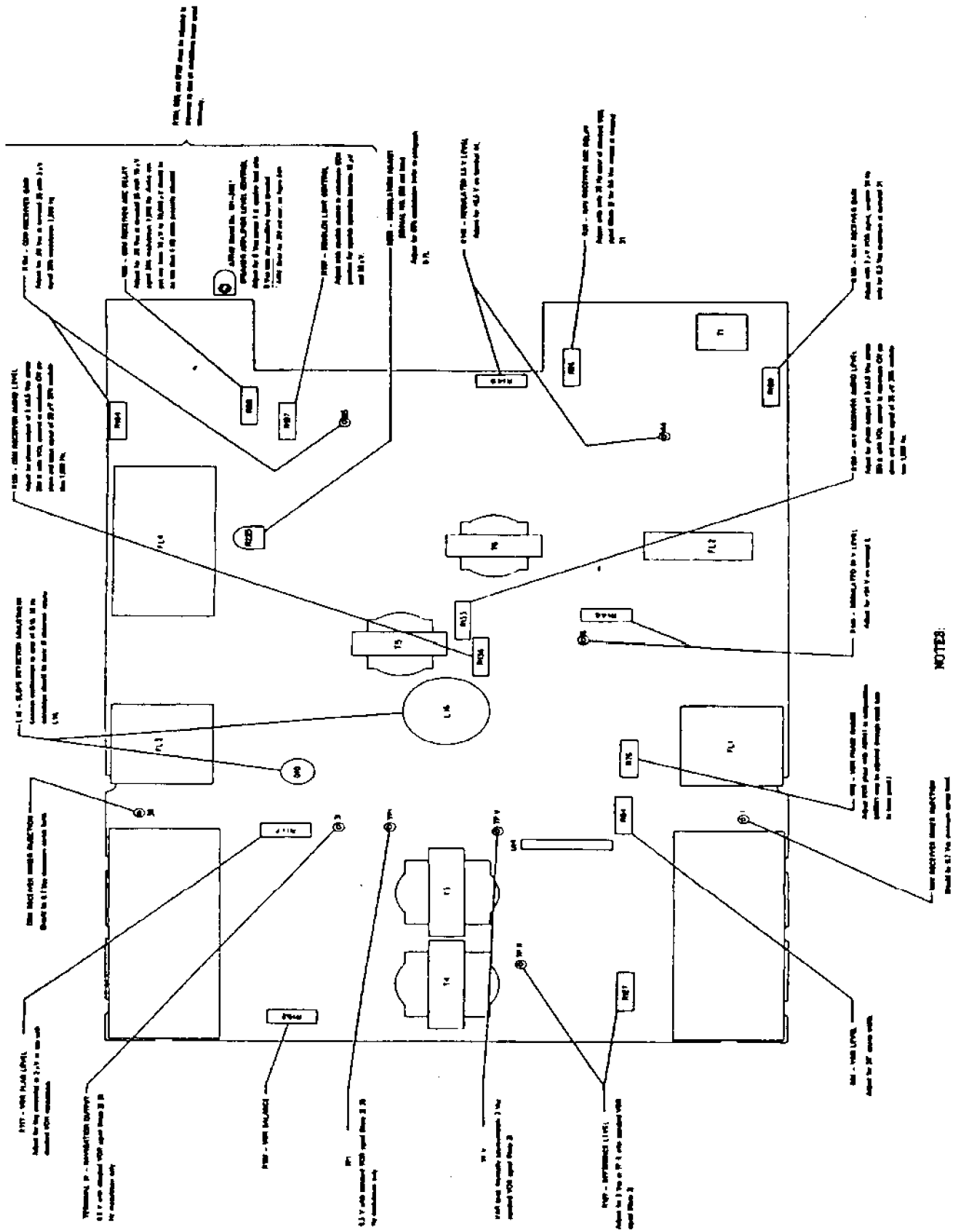

- NOTES:**
1. Unless otherwise indicated, frequency for COM adjustments is 121.00 MHz and NAV adjustments is 114.8 MHz.
  2. Standard VCR signal is 100  $\mu$ V at 114.8 MHz 30% modulation and 30 Hz and PM40 Hz.

A1. Receiver/Converter Assembly, Service Adjustments

# The Technician's Notebook

By Jerry Gordon

# RT-359A/459A

Rev. 3, Apr. 2000

## Class 1 Transponder

Weight 3.2 lbs. with mounting

Maximum altitude - RT-359A 15,000 feet, RT-459A To maximum aircraft altitude.

Receiver sensitivity -72 dbm to -80 dbm

Power - RT-359A 125 watts (typical), RT-459A 250 watts (typical)

## SERVICE INFORMATION LETTERS:

**AV 74-7 Bulletin #172** Poor RF grounding of transponder antenna. Be certain the transponder antenna is mounted with metal contacting metal. No gasket, no paint. RTV around the outside for sealing. Slow starting receivers when cold. 2. Receive noise reduction

**AV 75-1 Bulletin #175** Changes to 300/400 transponder. Mod M-1 Enables a remote IDENT switch. M-2 incorporates a new high temperature RF choke. M-3 Replaces A4C36 with an improved type with more heat resistance. Bulletin #176 adds improved ground for the GE cavity resonator. (If replacing the RCA cavity.)

**AV 76-11 Tech Aid #23** Diode installation to be accomplished when 2 transponders are Installed with a common remote IDENT switch.

**AV 79-23 Tech Aid #63** (Through 1978 Cessna's) Description of improvements made in the transponders: 1. Receiver sensitivity and MTL improvement. Especially on units with slow starting receivers when cold. 2. Receiver noise reduction. 3. Transmitter pulse width stabilization. 4. Encoder clock line filtering. 5. Addition of Insulating material to prevent shorting between the cavity and the A4 board assembly. Usually happens when the transponder is installed in the aircraft and the case is torqued. 6. Voltage regulator Improvements. A varistor is added from the LV + line to ground (pn 4555300030) 7. The fuse A4F1 is changed from 2 amp to 2.5 amp (pn 3297425000) **REPLACE ALL BLOWN FUSES WITH 2.5 AMP.**

**AV 79-32 Tech Aid #81** (beginning with RT-359A sn 22,800, RT-459A sn 16,500) A4R89 (150 ohm) is replaced by A4R128 (2.7K ohm) and the circuit altered so the resistor cannot be subjected to excessive current.

**AV 80-2 Tech Aid #92 MOD-4** (beginning with RT-359A sn 23,205, RT-459A sn 8050) Change to minimize "Hot Spots". This mod consists of removing 3 hot running transistors from the circuit board and mounting them on the side rails for better heat dissipation. This modification, "unofficially", should be mandatory.

## KIT 614060000 Includes all parts needed for Mod-4

**AV 80-116 Tech Aid #98** (applicable to RT-359A sn 23,205 - 24,300, RT-459A sn 8050 - 8525. Modification of printed circuit wiring pattern under A4T1 to remove possibility of high voltage arcing.

1. The printed wiring pattern on coder assembly A4 was changed to increase the ground plane area under power transformer A4T1. Under extreme environmental conditions, arcing could occur between this ground plane and the adjacent high voltage pad. The printed pattern identification of the A4 assembly in the affected area is either "19" or "20", printed in a circle on the flow side of the board. (See figure.)

2. In current production transponders, the printed wiring pattern under A4T1 has been changed to eliminate the possibility of high voltage arcing. Units with this change are identified as "MOD 5" for RT-359A's and RT-459A's.

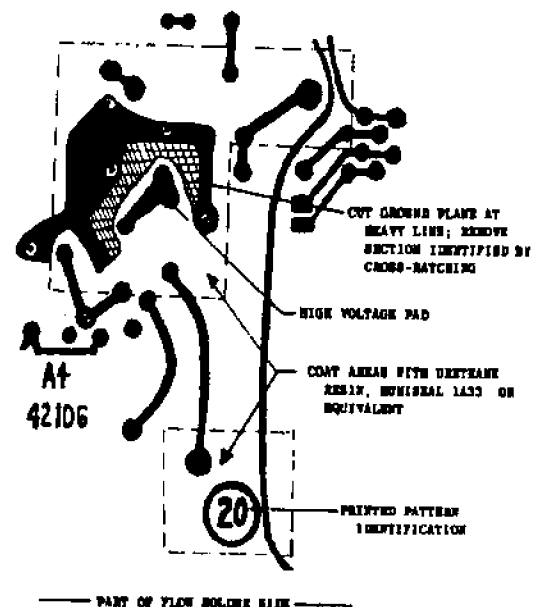

INSTRUCTIONS FOR ADDING COOLING AIR INLET HOLES

3. To modify a pattern "19" or "20" A4 assembly, proceed as follows:

- A. On flow solder side of coder assembly A4, cleanly cut ground plane area under transformer A4T1, as shown in figure, to assure a minimum clearance of 0.125 Inch from the high voltage pad.
- B. Apply hot soldering iron to the portion of the printed pattern to be removed, and lift off pattern piece.
- C. Make sure that all connections to the remaining ground plane are secure.
- D. Coat the high voltage areas on the flow solder side of A4 shown by broken lines on figure, and the area around A4CR12, A4CRI 3, A4R102, and A4R123 on the component side, with a urethane resin finish, such as HUMISEAL 1A33, to assure circuit protection. (HUMISEAL 1A33 is available through the Columbia Technical Corporation; 61-02 Thirty-First Avenue, Woodside, New York 11377.)
- E. Verify proper operation of the transponder, and identify it as "MOD 5", RT-359A or RT-459A.

1. S/N 19,655 and later, include air input ports for use with the aircraft avionics cooling system installed in MY '80 and later Cessna single-engine aircraft. If an MY '79 or earlier aircraft is retrofitted with the forced air cooling system, the transponder and mount in these aircraft can be modified to accept cooling air.

2. To modify an RT-359A earlier than SM 19,655, see figure. Remove the four screws that hold the end plate to the back of the unit, and remove the end plate. Locate and cut a hole in the end plate as shown in figure. Then replace the end plate.

3. Locate and cut a corresponding hole in back plate of the transponder mount. Make sure the hole in the mount coincides with the hole in the back of the receiver-transmitter.

4. Connect the cooling hoses to the transponder mount. Reinstall the transponder in the aircraft and verify performance.

**AV 82-14 Tech Aid #156** Changes of transistors and resistors in the IF circuit for product improvement. The receiver IF circuit change is incorporated in current production transponders for product improvement. Retrofit of earlier units is not recommended.

The following parts are affected by the introduction of the change:

REF DESIG	NEW DESCRIPTION	ARC PART NO.
A2A207	Type 2N4124	3696141240
A2A2010	Type 2N4124	3696141240
A2A2011	Type 2N4126	3696141260
A2A2012	Type 2N4124	3696141240
A2A2R26	1 KOHMS ±5%, 1/4W	
A2A2R27	1200 OHMS ±5%, 1/4W	
A2A2R28	2200 OHMS ±5%, 1/4W	
A2A2R31	1 K OHMS ±5%, 1/4W	
A2A2R32	2200 OHMS ±5%, 1/4W	
A2A2R35	4300 OHMS ±5%, 1/4W	
A2A2R36	4700 OHMS ±5%, 1/4W	
A2A2R38	100 OHMS ±5%, 1/4W	
A2A2R39	2200 OHMS ±5%, 1/4W	
A2A2R40	10K OHMS ±5%, 1/4W	

Type 2N3906 transistor used as video amplifier A2A2011 in the receiver circuit had to be selected to provide optimum performance under all operating conditions. To assure consistent receiver operation without transistor selection, A2A2Q11 was changed to a type 2N4126 transistor, and A2A2Q7, Q10, and Q12 were changed to type 2N4124. The value of resistor

**AV82-8 Tech Aid #151** Transponder modification to accept cooling air input. (Applicable to all 300 series Transponders Installed in Cessna MY '79 and earlier.

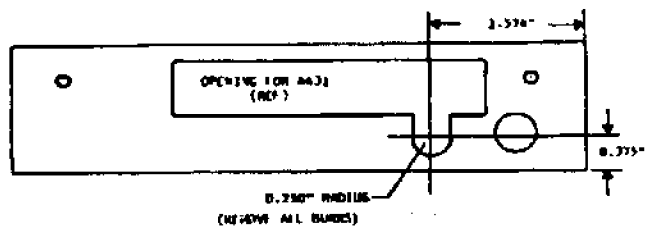
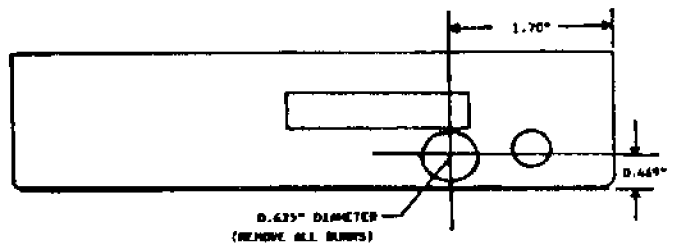

Figure 1. Transponder End Plate, Location for Cooling Air Input Opening



A2A2R26, was changed from 200 ohms to 100 ohms. Also the tolerance of resistors A2A2R26, R27, R28, R31, R32, R35, R36, R38, R39, and R40 was changed from 10% to 5% for added reliability.

**OBSERVATIONS:**

The RT-359A and Narco AT-50A are so similar they can almost be trouble-shot from the same manual. Other than the power supply and the receiver they have a mysterious resemblance. The part numbers are even the same except for the first digit. Video should be .5 volts with 64 dbm signal input.

**SERVICE HINTS:**

**COURTESY CUSTOMER SERVICE: SIGMA-TEK**

**Receiver Problems:** Mixer diodes and local oscillator are the most common. Poor sensitivity is the most common symptom. Replace the 3 transistors in the front end or the rear end (red dot or green dot) to bring up the gain to meet MTL only if the MTL is around -68 or -69 dbm. Do not replace these transistors hoping to cure a very weak receiver.

Oscillator problems are addressed by peaking it up. To tune the oscillator for best performance over wide temperature range-tune the coil when the unit is hot and adjust the resistor when the unit is cold.

**Power Supply Problems:** MOD 4 (Moving the 3 hot running transistors from the circuit board to the side rail.) is strongly recommended on all units if you want them to last. The 1400 volt and -8.2 volt lines are going to be the biggest problems encountered in the power supply. The 1400 volt line can fail in several ways.

A: The cavity can go bad. It can load down the 1400 volts and stop the power supply. Isolate by removing the anode lead and if the 1400 volts comes alive, you know you have a bad cavity.

B: Modulator Q-19 or Q-20 problems. Shorted transistors will pull down the 1400 volt line.

C: Defective transformer. Transformer resistance reading from top to bottom is .3 ohms on the primary and 520 ohms on the secondary. The reading is taken in circuit.

**Front Panel Parts Availability:** The parts manual only lists the complete front panel assembly.

Now you can purchase the individual parts to repair those broken or twisted shafts. See part numbers below.

**Part Numbers:**

Plastic screw for holding the transistor on sidewall:	0062260160
On-off standby knob:	4213500000
Collar with tab for knob:	4213100020
Coding knob on RT-359A:	4211000000
Push nut for knobs:	4119800010
Locking pawl:	2932400000
Crystal:	4214500000
Osc. Transistor:	422690001 red dot SRF 648
Cover screws:	0033820120

**RT-359A/459A POTS**

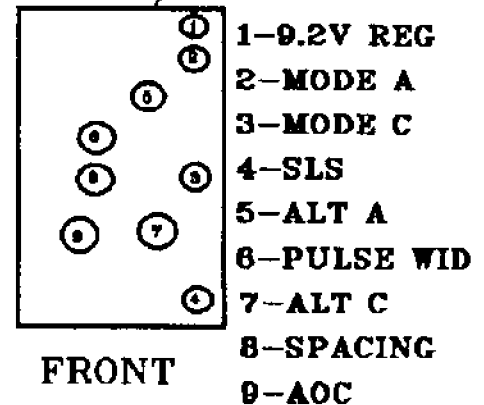

The reason the mode selector shaft gets twisted and won't allow the transponder to go into ALT mode, or intermittently work in this mode, is that the reply lamp is turned up too bright and heats the shaft. When the function knob is turned with a softened shaft, it will twist and retain that twist when cooled. Replace the knob.

**DECODER AND ENCODER CIRCUITS:**

Most common failure is U-6. (The Mode A Mode C flip-flop.) If the unit won't operate on Mode A OR Mode C, this is probably the culprit.

The AOC circuit, if mal-aligned will shut down the receiver and give the false symptom of a weak receiver.

**NOTES:**



- B. Com resistor improvement. A3A2CR8 & CR9 changed to 1N270 (p.n. 3441000000) and A3A2R46 changed to 100K variable resistor. (p.n. 44473001040)
- C. Correction of Nav reference oscillator start-up problems. A2A1C54 changed to 47pf @50v (p.n. 4626554700) and A2A1C110 changed to 3.3uf @15v (p.n. 4195503350).
- D. Prevention of short circuit during bench testing. Insulating plate (p.n. 3133800070) is held in place by transfer tape (p.n. 3667100480) and installed on the right side plate to insulate from the pc board at the Nav synthesizer.

**AV79-33 (supplement # 1) Tech Aid # 79** Change to prevent transmitter exciter damage from RF current spikes. A3A1C124 changed from 1000pf to 2.2 mfd @4vdc (p.n. 4011022250). Connect positive terminal to pad by A3A1E10 & A3A1T7 and negative end adjacent to A3A1U15 & A3A1C181.

**AV79-34 Tech Aid # 80 MOD 8/9/10/11 (RT-385A); MOD 12/13/14 (RT-485A)** Retrofit of earlier radios not required unless for use in 1980 and later aircraft. Radios in dual installations should be of same Mod status.

1. Modification to compensate for low microphone output level. (RT-385A MOD 8/9; RT-485A MOD 12/13) See drawing on page 5. Replace R-19 (68K) with 18k resistor.
2. Modification to reduce phone and speaker sidetone output levels. (RT-385A MOD 10/11; RT-485A MOD 14). See original documentation for details.

**AV80-3 Tech Aid # 88** (change beginning with RT-385A s.n. 17,500 and RT-485A s.n. 4275) Addition of isolation audio input circuit. With this Mod older radios can work in newer (1980 on) aircraft.

- Parts needed: 2 ea. 4.7k 5% 1/4 watt resistors (p.n. 11341-0472)

**Procedure for addition of audio input circuit.**

- a. On the flow solder side of the A3A1 board, cut the run between arm of A3A1R163 & A3A1C135.
- b. Solder a 4.7k resistor between the arm of A3A1R163 & A3A1C135 on the flow side across the cut. A3A1R213 (RT-385A) or A3A1R227 (RT-485A).
- c. Solder another 4.7k resistor from junction of A3A1R214 & A3A1C135 to pin 2 of A3A1P1. A3A1R214 (RT-385A) or A3A1R226 (RT-485A).
- d. Verify a speaker output of 7 + -.1vrms with input of .15 vrms 1khz at A3A1P1.
- e. Adjust A3A1R163 for speaker output of 7.5 vrms with input of 2.6 vrms 1khz to any aux audio input.

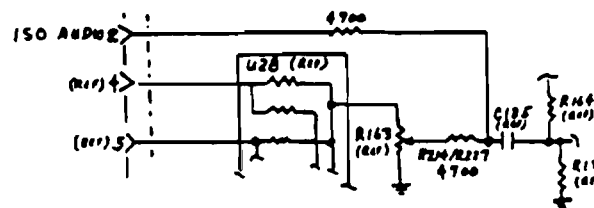

**AV80-13 Tech Aid # 96** (beginning with RT-385A s.n. 25,125 and RT-485A s.n. 5425) Capacitor change to improve reliability. A2A1C112, A3A1C149, and A3A1C153 are replaced by 1mfd @50vdc (p.n. 4195551050)

**AV80-17 Tech Aid # 90** (applicable to RT-385A between s.n. 12,000 and 18,000; RT-485A between s.n. 2,800 and 3,900). Possible frequency drift of the 3.2 mhz reference crystals. Check for an "S" on the crystal with date codes from 9/78 through 6/79. If Com crystal is in doubt, check A3A1C73 for being a fixed ceramic axial lead capacitor. If it is correct, replace the crystal. If it is the wrong capacitor, replace it with the correct type. (p.n. 4626552700). If Nav crystal is in doubt, replace it.

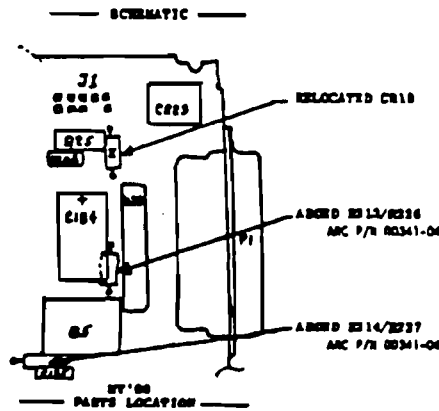

**AV80-29 Tech Aid # 113** (beginning with RT-385A s.n. 28,025 and RT-485A s.n. 6,250) Changes to reduce audio distortion. A3A1C138 changed to .47uf and A3A1C192 (1500 pf @50v) is installed.

- Parts : 1 ea. p.n. 4626441520 and 1 ea. p.n. 4626644740.

**CHANGE AS FOLLOWS:**

- a. On the flow solder side of A3A1, install the 1500 pf capacitor across pins 7 & 8 of A3A1U27. Identify the capacitor as A3A1C192.
- b. On the component side of A3A1, remove the original capacitor A3A1C138. Install the .47uf capacitor as A3A1C138.

AV 81-2 Tech Aid # 102 Improved mounting for 300/400 NAV/COM. Not a unit modification.

AV 81-4 Tech Aid # 123 Change of A3A1U27 from type TDA 2010 BD2 to type TDA 2020 BD2. Part number (4686500000) remains the same. The new one has a higher supply max rating. Heat sink (p.n. 4793900000) must be used when speaker amp is used on bench with radio open. When replacing U27 verify good heat sinking.

AV81-12 Tech Aid # 131 Change of A2A1VR1 and A3A1VR1 to 1N751A (p.n. 3147795110) 5.1 volt zener.

AV81-23 300 AND 400 NAV/COM Receiver-Transmitters, product improvement changes.

**A. Change to compensate for gain variation in NAV receiver first IF amplifier.**

1. Because of the wide variation in the gain of some type MC1349 integrated circuit devices used as the NAV receiver first IF amplifier in RT-385A and RT-485A Receiver-Transmitters, regeneration can occur if the device is exchanged. A change to add degeneration to assure consistent operation of the devices has been incorporated. The change consists of the addition of a 10-ohm resistor between capacitor A2A4X32 (at pin 3 of A2A4U2) and ground, and the verification that the value of A2A426 is 470 ohms.

2. To incorporate the change, see figure and proceed as follows:

- Unsolder end of A2A4C32 from ground.
- Solder one end of a 10 ohm resistor, ARC P/N 00341-0010, to the ground connection from which A2A4C32 was removed. Designate the resistor "A2A4R157."
- Wrap the free ends of A2A4C32 and A2A4R157 together as shown in in figure, and solder the junction. Make sure the combination is no more than 1/2 inch above the board.
- Cement the components to the printed wiring board using RTV.
- Determine the value of resistor A2A4R26. If the resistor value is not 470 ohms, remove the resistor and install a 470 ohm resistor.
- Verify operation of the receiver.

**B. Change to prevent breakdown of duplexer pin diodes due to static.**

1. In some aircraft, static buildup in the antenna system can cause the duplexer pin diodes A4A1CR3 and A4A1CR4 in the RT-385A or RT-485A receiver-transmitter to fail. A change has been incorporated. A 47K ohm resistor is added between the antenna connection and ground to dissipate any static buildup.

2. It is especially recommended for radios used in aircraft that have a history of static buildup and/or pin diode failure. Obtain a 47K ohm resistor, ARC P/N/ 0034104730. On the component side of A4A1, solder one end of the resistor to terminal A4A1E8; lap solder the other resistor lead to ground. Identify the resistor as "A4A1R13" (RT-385A) or as "A4A1R15" (RT-485A).

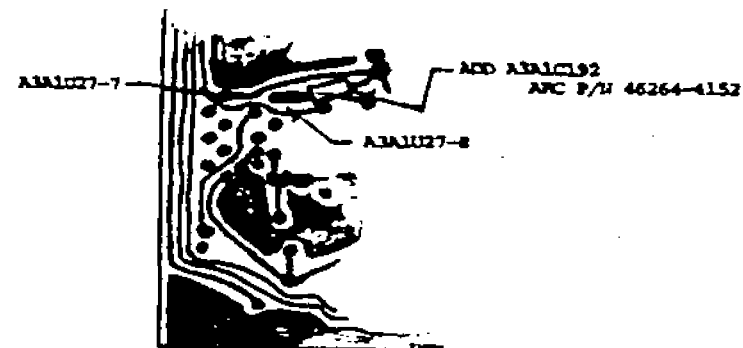
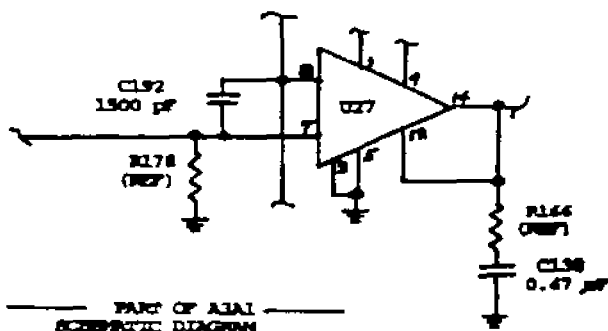

input run on A3A1 and ground; identify it as "A3A1RV4."

**C. Change to prevent audio amplifier damage by transient voltage spikes (RT-385A only).**

1. In some RT-385A NAV/COM receiver-transmitter, failure of audio amplifier chip A3A1U27 has been attributed to excessive voltage spikes on the + 28 volt input to the amplifier from the aircraft electrical system. A change has been incorporated in all current production radios. Varistor A3A1RV3 has been deleted, and diode A3A1CR22 has been replaced with suppressor A3A1RV4 (type 1.5K 47A), ARC P/N 4962804700.

2. The change may be incorporated in earlier receiver-transmitters for product improvement. Remove and discard varistor A3A1RV3 and diode A3A1CR22, between the + 28 volt

**AV82-11 Tech Aid # 152** Addition of ferrite bead (p.n. 35429-0001) to suppress possible uhf oscillation in the receiver mixer circuits. Incorporate when Q2 (type MEM 616) in either the Nav or the Com receiver must be replaced. Install on the drain lead (pin 1 of the transistor.) Designate the bead as "Z1".

#### **SERVICE BULLETINS:**

**SB No. 86-3 RT-485 NAV/COM** Com synthesizer improvement (Mod 3) Product improvement to any RT-485B NAV/COM which exhibits synthesizer intermittent operation. RT-485B synthesizers have unlocked at high transmit frequencies and at elevated temperatures. This service bulletin describes a parts change and a revised test procedure. Time requires, 1.0 hours for Mod.

Material Required:

<b>DESCRIPTION</b>	<b>QUANTITY</b>	<b>PART NUMBER</b>
CAP., 4.7PF, 50v, 10%	1	45675947100
DIODE, IN916	1	32433000500
RES., 330 OHM 1/8w, 2%	1	
RES., 150 OHM 1/8W, 2%	1	
RES., 560 OHM 1/8W, 2%	1	
RES., 1K OHM 1/8W, 2%	1	

Perform the following modification to the A3 Com synthesizer board as follows; Applicable to serial numbers thru 3,999.

1. Remove A3A1R196.
2. Add CR33 (32433000500) in place of A3A1R196. The anode CR33 connects to 5 volts.
3. Remove A3A1R199 & A3A1C162.
4. Add new C162 (46264210200) in place of A3A1R199 & A3A1C162.
5. Remove A3A1R134.
6. Add new C231 (45679547100) and new R134 (75000005610) in parallel in place of old A3A1R134.
7. Change existing:
  - R198 to 330 OHM 1/8W, 2%
  - R84 to 150 OHM 1/8W, 2%
  - R197 to 1K OHM 1/8W, 2%

#### **PERFORM PRELIMINARY TEST PROCEDURES.**

Connect a frequency counter to A3A1TP7. Adjust A3A1C72 for a frequency reading of 3.2 mhz + /- 25 hz. Connect VTVM to A3A1A1TP9. Set the RT-485B Com 1 frequency to 135.97 mhz. Adjust VCO tuning coil, A3A1A1-L27 for 10.0 + /- .2 volts at A3A1A1TP9. Key transmitter. Observe that the voltage at A3A1A1TP9 is not greater than 15 volts. Unkey the transmitter. Set the RT-485B Com 1 frequency to 118.00 mhz. Observe that the voltage at A3A1A1TP9 is greater than 3.0 volts. Key the transmitter. Observe that the voltage at A3A1A1TP9 is greater than 5.0 volts. Unkey transmitter. Reseal the core of A3-L38.

#### **TECHNICAL NEWS LETTER-8/1/91**

Applicable to all RT-385 NAV/COMS without Mod 14. Due to the non availability of mallory potentiometers, the new centralab potentiometers are slightly longer. This modification adds three spacers behind the 4660100000 mounting plate.

#### **MATERIAL:**

The material is available from Sigma Tek, Inc.

1. 2U055-001 Kit includes:
  - A. 1 ea. 40462001600 Potentiometer
  - B. 3 ea. 35595202400 Screw
  - C. 3 ea. 29347000800 Spacer

#### **TIPS AND HINTS:**

**SYMPTOM:** Display or one segment of a display not lit. Check solder connections where vertical display board connects to the motherboard.

**SYMPTOM:** No audio. Check audio output chip U-27.

**SYMPTOM:** Weak Com receiver. Check for leaky pin diode in T/R switch.



**SYMPTOM:** Garbled transmitter that clears up with alternator turned off. Check for open capacitor A4A2C2.

**SYMPTOM:** Weak audio especially when cold. Check C142 in the Com synthesizer. Also if you have a weak Com receiver audio, check C-53 in the Com receiver.

**SYMPTOM:** Dead Com or Nav sections. Check 3.2 mhz reference crystals.

Nav VCO adjustment: 108.0 and adjust coil for 5.0 vdc.

Com VCO adjustment: 118.0 and adjust A3A3L27 for 2.75 vdc. on A3A3TP9 with transmitter keyed.

In modulator Replace R-19 from 68K to 18K and adjust modulation as Mod 8 unit. There are 2 versions of the modulator as seen below.

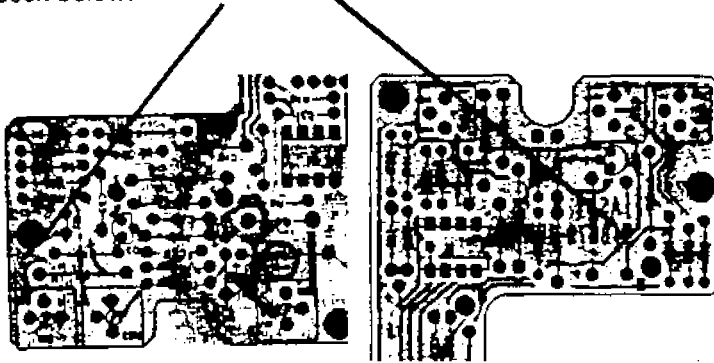

#### SERVICE HINTS:

Courtesy of Customer Service - Sigma-Tek

RT-385A & RT-485A are the same units other than the way they are channeled. The duplexer diodes in the transmitter are troublesome and should be checked. There is a capacitor in the modulator (C-39), tied between the 28 volt Com and the 28 volt transmit line. If it leaks it can kill the receiver. (Pre MOD-11 RT-385A). Audio chip U-27 problems traced to C-142. Problem seems to be temperature sensitive. VCO temperature problems

are common and can only be eliminated by proper cooling of the radio. The most common problem in the VCO is the oscillator itself. The problem could also be a component around the oscillator. Microphonics can be helped by adding more solder around the VCO can. Check the co-ax connections in the VCO. If you need to replace the VCO board assembly, Sigma-Tek now has an exchange program with a 12 month warranty. Call Sigma-Tek for details and pricing.

#### **RT-485A A6 assembly (photo transistor board)**

The lamps are set too low or too high when they are replaced in the board. The ribbon cable can be bad. A6A4 board is hard to trouble shoot. Get in diagnostic mode and start at U1 (ROM). Many think the processor is the ROM but it is not. The most common problem on this board is U1.

Keep alive is the second most common problem. There are 2 capacitors that fail on the 28 volt line that feed the keep alive. Incrementing and decrementing problems are generally the photo transistor or the light bulbs.

Memory lights probably are U1.

Com VCO: At 118.0 mhz key and tune VCO for 2.75 Volts at Test Point.

#### **NOTES:**

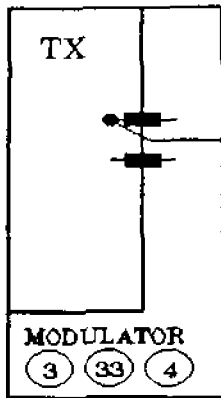

## TRANSMITTER ALIGNMENT

Frequency at 128.45. Key and adjust R-4 for 12.5 volts dc here.

## MODULATION ADJUSTMENT

Mike audio input .5vrms for Mod 0-7  
 Mike audio input .125vrms for Mod 8 & up.  
 1 khz audio. Adjust R-3 for 50% modulation.  
 Increase mike audio to 2.5 vrms for Mod 0-7 or  
 .825 vrms for Mod 8 & up. Adjust R-33 for  
 90% modulation.

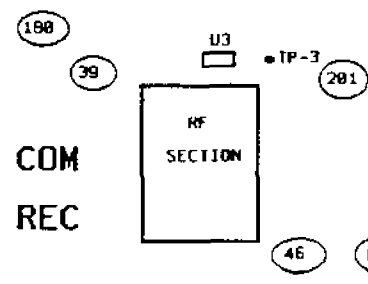

## COM AGC DELAY/IF GAIN

AC VTVM to TP-3 at 128.45 MHz/100uv.  
 Turn R-39 ccw to peak then ccw to  
 .125 vrms. 100uv input, adj vol cont  
 for 1 vrms. phone output. With 10uv  
 input, adj R-180 for .5vrms phone out.  
 R-51 is squelch limit control.

## AUDIO COMPRESSOR ADJUSTMENT

With 100 uv input at 30% modulation, adjust phones to 1vrms.  
 Raise modulation to 95% and adjust R-46 until phone output  
 is the same as at 30%.

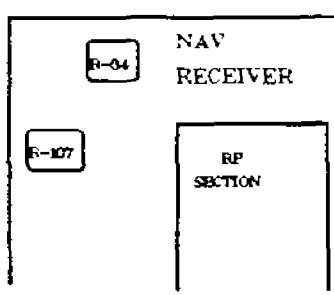

## NAV AGC ADJUSTMENT

Scope, AC VTVM on demod and connect  
 1 mfd. cap across demod to ground.  
 100 uv signal @30 hz. 114.9 mhz.  
 adjust R-107 for .48 vrms.  
 Lower signal to 2 uv and adjust  
 R-34 for .37 vrms +1 -0.  
 Repeat and adjust for minimum  
 distortion.

## ADJUST FOR 7 WATTS INTO 8 OHMS (SPEAKER OUT)

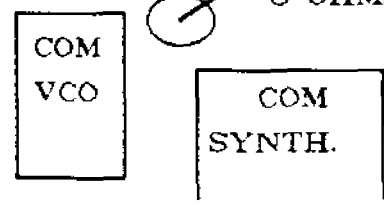

# The Technicians Notebook

By Jerry Gordon

# TDR-950

Weight: 2.0 lbs (Including mounting tray)  
Power: 13.75vdc .8 to 1.2 amps.  
Sensitivity (MTL): -71 to -77 dbm.  
Power: 250 watts (TDR-950) 140 watts (TDR-950L)

Revision 2, Apr. 1998

## SERVICE BULLETINS AND SERVICE INFORMATION LETTERS:

1R1TDR-950/950L TDR-950/950L Suppression Circuitry Jan 2/77  
2TDR-950/950L TDR-950/950L L-Band Interference Suppression Mar. 1/76  
3R1TDR-950/950L Reduction of L-Band Interference Apr. 1/77  
4TDR-950/950L Neutral Lamp Filters Jul. 15/76  
5TDR-950/950L Reply Clock Timing Feb. 1/77  
6R1TDR-950/950L Lamp DS4 Relocation Mar 15/77  
7TDR-950/950L Power Interrupt Oscillation in 28 volt systems May 16/78  
8TDR-950 Reply Pulse Spacing Oct. 16/78  
9TDR-950/950L Incoming Suppression Jan 19/79  
1-75TDR-950 Transponder antenna Identification Oct. 1/75  
2-75TDR-950 28 to 14 Volt Power Conversion Kit Installation Oct. 15/75  
3-75TDR-950 Installation Of Neutral Lamp Filters Dec. 1/75  
4-75TDR-950/950L TDR-950/950L Dual installation Dec. 15/75  
1-76TDR-950/950L TDR-950/950L Suppression Circuitry Dec. 15/75  
2-76TDR-950/950L Defective Switch Board Assemblies Jul. 1/76  
3076TDR-950/950L Erroneous IDENT Illumination When Transponder is Turned On Jul. 20/76  
4-76TDR-950/950L Transmitter Frequency Adjustment Sep. 1/76  
5-76TDR-950/950L Transmitter Power Measurement Dec. 1/76  
1-77TDR-950/950L Cavity V1 Power Measurement Mar 1/77  
2-77TDR-950/950L 28 Volt Installation Power Interrupt Mar 1/77  
3-77TDR-950/950L IF Circuit Alignment May 1/77  
1-78TDR-950/950L Local Oscillator Alignment for TDR-950 Transponders  
Above sn 7400 and TDR-950L Transponders above sn 1700 Jun. 23/78  
2-78TDR-950/950L F1/F2 Pulse Spacing Sep. 26/78  
1-79TDR-950/950L Transmitter Frequency Pulling Due to Antenna Contamination Apr. 2/79  
2-82TDR-950/950L Preferred Replacement for Q19 Feb. 18/82  
10R1TDR-950/950L Replacement of Mode Selector Aug. 2/83

## FOLLOWING IS COURTESY OF AL TATUM, CUSTOMER SERVICE, S-TEC CORP.:

### 1. Weird Problems/Solutions.

A. 5V feedback from Mode C Encoder (such as a shorted isolation diode between TDR-950 and Encoder) before transponder is powered up will cause transponder to never come ready.

B. A stuck Ident button will complete last Ident correctly but will not Ident again and will cause transponder to not come ready on any further power ups.

C. All of the operation (except Transmit function) can be checked with the transponder in Standby. p73

D. The best way to adjust coil L1 and L4 is with a spectrum analyzer. Look for a frequency blip at 136.25 mhz, X2, X3, and X4. For local oscillator out of adjustment, the frequency pulses will be scattered across the band. (Hook a 1200S probe to the IF CASE to monitor.)

E. For troubleshooting in the IF area, set the frequency on a 1200S spectrum analyzer to 60 mhz and set the 1400A generator for continuous output (not pulse). Use probe on the spectrum analyzer for peaking and for troubleshooting.

F. Faceplate replacement number is 628-5637-XXX where XXX = 001 thru 006. Note: only black (001) is available.

G. TDR-950 failure to power up in the plane, OK on the bench: The TDR-950 power supply has a sneak path that causes problems when anything else is tied to the altitude lines from the altitude encoder. This can be a GPS, Loran, Altitude Nag, or Altitude Alerter. When the problem shows up, the TDR-950 will not power up unless the problem item is turned off first. Fix: Diode isolate the ten altitude lines at the rear of the TDR-950. The dual installation in the TDR-950 manual gives part numbers, and information to accomplish this.

H. There is a new minor change to the manufacturing of the TDR-950 by S-TEC. This change was implemented for the US. Navy to enable the unit to work with the new TCAS System the Navy was having installed into existing planes.

This change incorporates added shielding for the local oscillator since the LO in the older units radiated through the front panel causing interference within the TCAS System. It uses a new shield beneath the LO/IF area and extra caps to reduce this interference. This is a production change and there is no service bulletin assigned. If you experience problems with the TDR-950 causing interference with a TCAS System, contact S-TEC Customer Service.

## II. Unusual/Unknown part numbers:

### A. 28/14 volt adapters.

1. 28/14 volt adapter P.N. 628-8108-001. Cost is same as P.N. 628-7990-001, except a 56 ohm 15 watt resistor is thrown in free.

### B. Etched side of PC board.

1. Solder covers on etched side of the PC board:

Large - 628-5989-001

Small - 628-5749-001

2. Insulator for large cover is 628-6361-001

3. Plastic HV shield for etched side of board is 628- 5625-001

### C. Cavity wire P.N.

1. Small coax (wire 1 & 2) is 425-0222-010

2. Large coax (plate wire) is 425-0222-040

3. Wire: Black is 439-0592-00, Brown is 439-0592-020

4. Shielded cathode wire is 439-0597-040

5. New Cavity Tube is P.N. 277-0446-030 from S-TEC and must use G.E. tuned wires lengths (wire 2 coax, plate coax, and cathode lead).

### D. Switch Plate

1. DS4 = 262-1424-040. NOT 262-1424-010 as in the manual.

### E. Component side of PC Board.

1. Q-19, P.N. 352-1528-010, should be type ST-1423 or Aol 91EQ107.

### F. Face Plate:

1. Knob 628-7877001 is also used in RCR-650 instead of 628-5465-001

## III. To convert from old RCA to new GE Cavity:

1. Replace heatsink with 628-5624-001. Add 2 ea. straps PN628-5610-001.

2. On page 5-5: Replace old wire 2 with wire 2 for GE cavity. Connector is P.N. 361-0353-020. Replace old (red) plate wire with RG-316 (P.N. 425-0222-040) for GE cavity. Replace old cathode wire with No. 22 AWG shielded wire, P.N. 439-0597-040 for GE cavity .

3. Use RF beads, P.N. 288-1325-010 (3 ea.) on plate. Use RF beads, P.N. 288-1377-020 (3 ea.) on cathode and 3 ea. on brown filament wire.

4. Apply silicone silastic over plate pin at tube cavity and end of HV plate wire.

5. Wire 1 does not need to be replaced as it is the same length for both RCA and GE cavities.

6. No changes are required for replacement of old GE to new cavities.

NOTES: New address for S-TEC: One S-TEC Way, Municipal Airport, Mineral Wells, TX 76067. S-TEC is the Factory Repair Center for MICRO LINE in the USA.

# The Technician's Notebook

By Jerry Gordon

# Terra by Trimble

Revision No: 0 10/1997

---

**The following is courtesy of Bill Eldred with Trimble Technical Support. These are the most asked questions and his replies.**

## TX760D Com Transceiver

**Garbled transmitter:** L-601 on Syn/VOX board resonating. Change L-601, Trimble p/n 9-1845-132-00.

**External intercom does not squelch properly:** On Syn/VOX board, adjust R-642 full DECREASE. Leave SJ-601 and SJ-602 installed.

**Keyed intercom desired:** R-642 full DECREASE, R-630 full INCREASE. Leave SJ-601 and SJ-602 installed. Toggle PK-9 pin 14 with PTT switch to ground to energize intercom.

## TN200 Nav Receiver

**Interface to other than Terra CDI/HSI/Converters:** Trimble Service information letter SIL 190000350-34-00 provides a list of pertinent documents needed for field adjustment of composite level. Level is fully adjustable from 100 mv rms to 1.0 vrms to drive standard ARINC indicator/converter. WILL NOT drive Narco time shared indicators. Note: TN200D composite output is ARINC 0 degree phase.

## TRT250D Transponder

**Mode S/TCAS environment c compatibility:** Mandatory Service bulletin SB-104. \$298.00 flat rate. Legal units identified by Mod status (2 for TRT250D and 5 for TRT250)

**Mode C encoder paralleled to another device,** such as a second transponder, GPS, etc. : TRT250/250D must have external isolation diodes installed in parallel installations. Consult installation manual of other device to determine it's isolation requirements.

## AT3000 Altitude Encoder

**Altitude error:** On initial adjustments to new unit, allow 1 hour warm-up prior to calibration.

**New unit won't power up:** Mod 4 and below AT3000's could accept 11-33 vdc switched power at pin 8 or 14. Mod 5 AT3000's MUST have switched power applied to pin 14 or they will not operate.

## TFT100D

**Short range and/or large quadrantal error:** Usually caused by insufficient bonding of antenna to airframe. Burnishing screw hole is not enough. Strip the ENTIRE antenna footprint of paint. Alumiprep and Alodine skin, and seal antenna with approved aircraft sealant to keep out dirt, moisture and oil. Units that develop these problems after a time of good service need the antenna pulled and the above procedure performed. When system

is installed in homebuilt (usually composite) aircraft, large quadrantal errors are common. If there is not enough adjustment available using R-312, more correction can be found at R-318 on the logic/audio board of the receiver.

**Receiver won't power up:** Plug in the indicator.. It supplies power to the entire system.

### **TMA330/340/350D (TSO and non-TSO)**

**Unit keys all by itself:** Unit can possibly be damaged when installed with certain com radios that leave DC bias voltage on the mic audio line continuously. If this bias level (loaded) is greater than 9 vdc, select and install a resistor to ground on each mic audio output to the com that will drop the DC bias to between 8 and 8.5 vdc.

**Marker Beacon lights flash when com is keyed:** Usually caused by improper construction of the marker coax. When building the coax, install the center conductor pin so that the shield is butted up to the Molex connector. Insure the jumper for the shield ground is ½ " long or less.

### **TRA3000/TRA3500 Radar Altimeter systems**

**System attempts to re-lock above 2500', thus giving the pilot a heart attack:** Almost always caused by a noise source on the airframe that the altimeter attempts to lock on to. Most likely caused by a loose, dirty or missing bonding strap on a gear door, access panel or control surface. I usually get this call after an aircraft has come out of annual. Locate the offending panel and bond it to the airframe.

**TR130/TR140 Rad-Alt indicators inop:** If strut switch is not used, indicator must still be configured to enable strut switch, otherwise the unit will not operate.

**"My Radar Altimeter has a 100 to 200 ft. Error":** Don't believe it! This system is being compared to the aircraft's baro altimeter which can be off by as much as 150 feet. The ONLY acceptable method of determining altitude is to fly a published approach checking altitude over the Markers.

### **TX720 Com Transceiver**

The old style push button channel selector switches are no longer replaced as a pre-assembled, pre-wired assembly. They are supplied as individual switches. The following drawings are necessary for assembling and wiring the switches in the radio.

Save the drawings on the next two pages for reference as they do not normally come with the new switches. If you have any questions regarding these switches, the switches in any other Trimble unit, or any of the material in this notebook, contact Bill Eldred at (800) 995-9551 or (512) 432-0439 (Direct line to Bill), or internet at [bill\\_eldred@trimble.com](mailto:bill_eldred@trimble.com). FAX (512) 836-9413.

### **NOTES:**



This drawing is needed to assemble the new style switches for the TX-720. Save it as it does not appear in any manual.

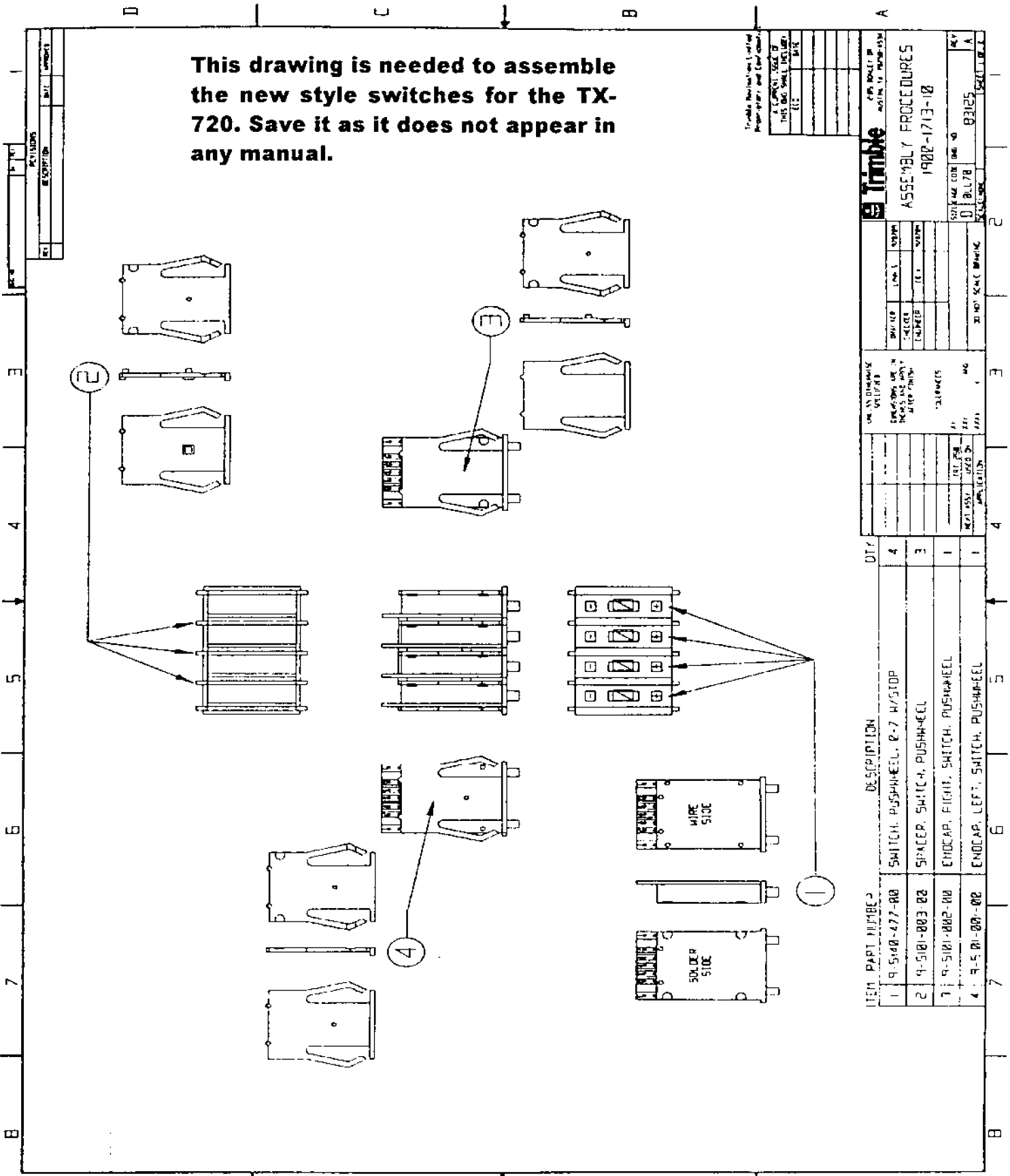

Trimble Publications Limited  
Proprietors and Publishers  
A CANADIAN COMPANY  
THIS DRAWING SHALL INCLUDE  
REV. DATE

TRIMBLE	REV. DATE	BY
ASSEMBLY PROCEDURES		
1902-1713-10		
SIZE AND CODE	83125	REV. A
DATE	01/78	

ITEM	PART NUMBER	DESCRIPTION	QTY
1	9-5100-477-00	SWITCH, PUSHWHEEL, R-7 W/STOP	4
2	9-5101-003-00	SPACER, SWITCH, PUSHWHEEL	3
3	9-5101-002-00	ENDCAP, RIGHT, SWITCH, PUSHWHEEL	1
4	9-5101-000-00	ENDCAP, LEFT, SWITCH, PUSHWHEEL	1



## The Technicians Notebook

By Jerry Gordon

## VHF-251/A/E

Revision 2, Apr. 1998

Weight 3.8 lbs. including tray

Transmitter power 10 watts nominal. Modulation 85%. Sidetone 5mw @500 ohms.

Receiver sensitivity 3.0uv for 12 db min. S+N/N. AGC 10 - 20,000uv within 3db.

Audio output 5 watts @ 3.2 ohms and phones 50mw @ 500 ohms.

Display: 262-1390-010 Volume Knob: 628-5490-002

The VHF-251A is a completely redesigned unit by S-TEC that is directly interchangeable with the VHF-251, which is no longer in production.

### VHF-251A SERVICE BULLETINS:

**SB-1** (Applicable to SN 5001 thru 5441) Upon release of the microphone key switch at the end of a transmission, it tends to lose power regulation, causing the previously store frequency to be channeled (5001 thru 5188). When a powered up VHF-251A shares the intercom with a VHF—251, the audio panel headphones output tends to become severely attenuated (5001 thru 5441). After a VHF-251A has been in continuous operation for 1-2 hours, the audio panel output

### VHF-251 SERVICE BULLETINS:

**SB-1** Early serial numbers. Shorten squelch tail. Change A2C78 from .47uf to .33uf tantalum @35v.

**SB-2** (Applicable SN1405 or lower) Select/Recall switch difficulty. Addition of A5Q1 & A5R2. Time 30 min.

**SB-3** ( Applicable or lower) If T/R relay chatters, physically rewire A1K1. No parts. Time 45 min.

**SB-4** (Applicable SN1761 or lower) Placement of transistors for better heat dissipation. (A1Q1, Q2, and CR3).

**SB-5** Not issued.

**SB-6** (Optional on all sn's) Revision 1 dated 9/15/76. Auto-squelch modification. To eliminate no-signal noise coming up before squelch activation, resulting in a tailing noise effect. Also, higher frequencies may activate the noise squelch, resulting in rapid chopping of the signal. Reported as garbled audio. (See bulletin for parts list.) Time 90 min.

**SB-7** Improve audio quality. (See bulletin for parts list) Time 90 min.

**SB-8** Parametric oscillation in dual installations. 2 ea. diodes (1N3070).

**SB-9** Receiver range (Eliminated in SB-10). De-sensitize the noise squelch to ignition noise. Done after mod 6.

**SB-10** (Applicable below SN14,000) Making the noise squelch nearly immune to ignition noise and stabilize the squelch circuit operation so noise squelch can be set at 1.5uv. Time 2 hours. (Read SB-14 first). (See bulletin for parts list).

**SB-11** (Applicable below SN10,858) Reduces the no-signal noise generated by the transceiver. Time 30 min. Change R-32, R-33, and C-35. Kit part number 628-7613-001.

**SB-12** (Applicable below SN10,782). Distorted transmissions. Add RF contact strips. 2 ea. Part number 628-7876-001. Time 15 min. (See SB-17).

**SB-13** (Applicable below SN23,038). Unit produces high level of broad band noise. Factory mod only!

**SB-14** (Applicable SN24,950 through SN25,908). Reduces noise in aircraft audio system added by the VHF-251 intercom. See bulletin for parts. Time 60 min.

**SB-15** (Applicable below SN23,038 and without SB-13 performed). SB-15 produces the same results as SB-13. Kit part number 628-9278-001. Time 2 hours.

**SB-16** (Applicable below SN 24,950). Adding intercom adjustment. See bulletin for parts list. Time 1.5 hours.

**SB-17** (Applicable below SN 28,409). Distorted transmissions due to frequency modulation of the transmitter. Other than chemicals and the modification sticker, the parts required for this modification are as follows: 1 each of 628-5352-001, 628-5362-001, and 628-5363-001.

**SB-18** (Optional on all VHF-251 transceivers, **SB-12** on VHF-251E transceivers) To increase the bandwidth of a VHF-251 from 720 channels to 760 channels (118-136.975 mhz). A microprocessor board replaces selected components of the wafer switch assembly. Estimated time of 2 hours to modify and test one transceiver. Parts required from S-TEC: 1 ea. of the following: 03884 PC Board (microprocessor) - 37022009, wire - 628-7876-001, placard - 2717, capacitor (47 mfd) - 2 ea. 44487, spacer.

## **SERVICE INFORMATION LETTERS:**

**2-76** (Applicable VHF-251 P.N. 622-2078-001 through 622-2078-006) The switch/pot assembly has been changed to an improved version and carries part number 628-6014-001. See this service letter for the correct part numbers if you are using an older manual.

**3-76** Help in adjusting the auto-squelch and some other tips.

The adjustment of automatic squelch circuits contained within the VHF-251 need not be as complicated and confusing as reports and questions from the field seem to indicate. The following discussion summarizes squelch operation and adjustment and explains the reason a particular adjustment is made. For a thorough discussion, refer to the VHF-251 instruction book theory and maintenance sections. Page 73

### **NOISE SQUELCH**

Turn carrier squelch potentiometer A2R63 full counterclockwise and RF generator output level to 3 uv. Adjust noise squelch threshold potentiometer A2R75 until audio (1000 Hz, 30% modulated) just appears. Reduce generator output level for maximum attenuation and note that receiver is muted (squelch closed). Slowly increase the RF generator output until the 1000 Hz audio just appears. Observe the generator output level setting. Result: Generator output is 3uv. Readjust noise squelch as necessary until the 3uv threshold is achieved. This adjustment sets the threshold at which receiver noise from the detector triggers the squelch. For levels above 3 uv the squelch, when correctly adjusted, will be open. Below 3 uv (level established for unintelligible noise) the squelch is closed. Generally, high ambient noise levels will not be of sufficient amplitude or duration to open the squelch. To facilitate adjustment as previously described, the carrier squelch circuit must be disabled so that noise squelch may be set independently. This is accomplished by desensitizing the carrier squelch to a point where even a very strong carrier will not cause the squelch to open (full counterclockwise rotation of R63). With the carrier squelch disabled, the noise threshold is easily adjusted.

### **CARRIER SQUELCH**

Apply a 20 uv signal modulated 85% with 9000 Hz and adjust carrier squelch potentiometer A2R63 until audio just appears. Reduce generator output below 20 uv until audio is squelched. Slowly increase generator output level until the 9000 Hz audio again appears. This level must be between 20 and 25 uv. Readjust as necessary until correct results are obtained. The carrier squelch adjustment sets the threshold at which a received carrier opens the squelch. Carrier squelch operation is controlled by AGC voltage and, when correctly adjusted, triggers the squelch upon reception of a 20 uv or larger rf input. Without a detected carrier, AGC voltage will drop off and the squelch will close. To adjust carrier squelch the noise squelch must first be disabled. This is accomplished by applying an rf input signal that fools the noise squelch into thinking the received signal is pure noise. With this type of input applied the carrier squelch threshold may be adjusted without interference from the noise squelch. As noted in the carrier squelch adjustment procedures, an rf signal modulated 85% with 9000 Hz is used for adjustment. This particular modulating frequency is used because it remains above the noise squelch pass band (noise squelch thinks 9000 Hz is noise) while at the same time remaining well below attenuating characteristics of the receiver crystal filter. With the noise squelch disabled, carrier squelch threshold is set to trigger on a 20 uv signal with an 85% modulated carrier.

### **ADDITIONAL COMMENTS & TIPS**

All rf input levels specified for the testing and alignment of the VHF-251 are in hard micro volts. This is a measure of electromotive force. Since signal generator attenuator dials are calibrated in soft micro volts (the voltage actually seen across the output connector will agree with the attenuator only when the generator is loaded with its design load impedance) an additional device must be used to ensure a constant load impedance on the generator. Loading the generator with this constant impedance ensures that regardless of the input impedance of the unit under test the attenuator dial setting will always be equivalent to the actual generator output, that is, hard micro volts. To use the signal generator attenuator readings as hard micro volts (what you see is what you get) a 50 ohm, 6 db pad must be connected between the generator and the transceiver under test. If a 50 ohm, 6 db pad is not available, the attenuator dial should be set to 1/2 of the desired output in micro volts (6db lower signal level). After adjustment of squelch threshold, all boards and covers should be replaced and the threshold levels rechecked. A different threshold level from that observed initially indicates rf leakage from the signal generator. To overcome this problem, relocate the generator at least 4.6 meters (15 ft.) from the radio when setting the squelch. A 20 db pad should replace the 6 db pad previously used at the generator output. Carrier squelch should now break at an attenuator setting of 100 uv, and the noise squelch at 15 uv.

**NOTES:** Servicing the VHF-251 without a communications monitor is very difficult. The transmitter FM'ing problem is almost impossible to see without the ability to check an FM transmitter. The IFR FM/AM 500 or 1200 makes the job very easy. With the IFR box function selector on receive and the modulation meter set for FM, a slight deviation with heavy modulation is acceptable and will give good AM transmissions. Any measurable deviation and you had better look at the VHF 251 again before you release it. If you have an audio howl complaint, check for shorted CR-23 on the receiver board. Also check C-54 and C-1.

# The Technicians Notebook

By Jerry Gordon

# VIR-351

Revision 2 Feb., 1998

Weight 3.3 lbs including tray and connectors.

Voltage 13.75 volts. PWC-150 power converter used for 28 volt systems.

Aural sensitivity: 3 uv max. for 10 db s+n/n, Nav sensitivity 3 uv max. for VOR/LOC flag out of view.

AGC <2 db from 10 to 10,000 uv. Audio output: 50 mw into 600 ohms. Audio load impedance 500-600 ohms. OBS resolver ARINC 547; ORZ'd at 300 degrees. VOR accuracy 2 degrees. VOR/LOC deviation loads; 6 1000 ohm loads max.; dummy loads not required. Flag loads; 6 1000 ohm loads max.; dummy loads not required. TO/FROM flag loads; 2 200 ohm loads max.; dummy loads not required. Radial read-out sensitivity less than 3 uv with accuracy within 2 degrees. TO-FROM Flags 40 mv for fully in view. NAV Flags fully in view at 180 mv, fully out of view at 245 mv.

IND-350 Weight 1 lb. IND-351 Weight 1.3 lbs. IND-350A/IND-351A/IND-351C/IND-351D Weight 1.5 lbs.

IND-350:

P.N. 622-2082-001: 200 OHM NAV flag horiz at bottom of ind.

P.N. 622-2082-002: 1000 OHM NAV flag at angle of bottom ind.

P.N. 622-2082-003 Same as -002 but with RNAV annunciator.

IND-350A: P.N. 622-4477-001 Replaces IND-350.

IND-351: P.N. 622-2083-001: 200 OHM NAV & GS flag horiz on bottom and vertically on side of ind.

P.N. 622-2083-002: 1000 OHM NAV & GS flags at angle on bottom and side of ind.

P.N. 622-2083-003: Same as -002 but with RNAV annunciator.

IND-351A: P.N. 622-4478-001 Replaces IND-351.

IND-351C: P.N. 622-2425-001: 1000 OHM NAV & GS flags. P.N. 622-2425-002: Same as -001 but with RNAV annunciator.

IND-351D: P.N. 622-4479-001: Replaces IND-351C.

VIR-351 P.N.: 622-2080-001, 011 = Black face plate. 622-2080-002, 012 = Blue face plate.

622-2080-003, 013 = Green face plate. 622-2080-004, 014 = Red face plate.

622-2080-005, 015 = Brown face plate. 622-2080-006, 016 = Gray face plate.

PWC-150 Power converter: Weight 1.5 lbs. Input 27.5 VDC. Output 13.75 VDC, NAV 2 amps continuous, COM continuous 5 amps for 15 seconds, 1 amp for 45 seconds. COM intermittent 5 amps for 1 minute at 10 minute intervals.

## SERVICE BULLETINS:

VIR-351 (-001 THRU -005)	SB-1	IMPROVE AGC DYNAMIC RANGE.
VIR-351 (-011 THRU -016)	SB-1	FM BROADCAST INTERFERENCE.
VIR-351 (-001 THRU -005)	SB-2	NOT ISSUED.
VIR-351 (-011 THRU -016)	SB-2R1	MINIMIZE ROTOR MODULATION IN AUDIO.
VIR-351 (-001 THRU -005)	SB-3	POWER SUPPLY INTERFERENCE TO ADF.
VIR-351 (-011 THRU -016)	SB-3	SCALLOPED VOR SIGNALS.
VIR-351 (-001 THRU -005)	B-4R1	FM BROADCAST INTERFERENCE.
VIR-351 (-011 THRU -016)	SB-4	IMPROVED OPERATION WITH DOPPLER VOR SIGNALS.
VIR-351 (-001 THRU -005)	SB-5	REDUCED EFFECT OF SCALLOPED VOR SIGNAL.

VIR-351 (-001 THRU -005)	SB-6	IMPROVED OPERATION WITH DOPPLER VOR SIGNALS.
VIR-351(-001 THRU -005)	SB-2-75	INCREASE AUDIO OUTPUT AT LOWER MODULATION LEVEL.
VIR-351 (-001 THRU -005)	SB-1-76	NEW SWITCH/POT ASSEMBLY.
VIR-351 (-001 THRU -005)	SB-2-76	ADJUSTMENT OF RF AGC DELAY CIRCUIT.
VIR-351 (-001 THRU -005)	SB-3-76R1	ROTARY SWITCH INSULATOR.
VIR-351 (-001 THRU -005)	SB-1-77 I	INTERFACE WITH 331A-3G COURSE INDICATOR.
VIR-351	SB-7	All that have revision C of the A6 P.C. Board Assembly, to meet

ICAO ANNEX 10. In some situations, **FM broadcast stations may interfere with NAV receiver operation.** Consists of adding some components and removing or replacing others. Estimated time to modify and test one receiver: two hours. Contact S-TEC for details.

IND-350	SB-2	VOR/ILS METER MOVEMENT REPLACEMENT.
IND-350/351	SB-1	IMPROVE INDICATOR ILLUMINATION.
IND-351	SB-2	VOR/ILS & GS METER MOVEMENT REPLACEMENT.
IND-351	SB-1-76	SPACER BLOCK MOUNTING SCREW LENGTH.
IND-351C	SB-1	VOR/ILS & GS METER MOVEMENT REPLACEMENT.
IND-351C	SB-1-76	CT SYNCRO B2 SHAFT EXTENSION ADHESIVE.
IND-350/351/351C	SB-1-77	NAV & GS FLAG REPLACEMENT.
IND-350/351/351C	SB-2-77R1	MOVEMENT STOP CLEANING PROCEDURE.
IND-350A/351A/351D	SB-1-79	KEYED MATING CONNECTOR.
IND-350/350A/351/351A/351C/351D	SB-1-80	MOUNTING SCREW LENGTH.

**Alignment of VOR Board A4 (628-5010-001/002) only.**

1. 110.2 mhz 1000 uv std. VOR test signal.
2. Scope to A4TP2 and adjust A4R22 Ref Level for neg pulse width of 70 us. +-4us.
3. Gen and OBS to 60 degrees. Adj A4R4 VOR zero to center needle.
4. Gen and OBS to 150 degrees. Adj A4R30 VOR track to center needle.
5. Repeat until error within 1 degree.
6. OBS to 0 and gen to 180 degrees. Adj A4R5 VOR BAL for 1/2 of the error.
7. Repeat 60 and 150 degree alignments and VOR BAL adjustments until all are within 2 degrees.
8. Gen and OBS to center needle exactly. Move gen off 10 degrees and adjust A4R20 VOR/LOC DEV for 150 uv or 5 dots. If A4R20 does not have enough range, sub A4R10 on VOR converter board. If you change A4R10, repeat VOR alignment.

**Alignment of VOR (Board A4 (628-5010-003) only.** Same as above until step 8. Deviation adjustment is A5R20.

Localizer adjustment, ALL.

1. Gen to LOC center.
2. Adjust A5R26 to center needle.
3. Gen to 4 db (15090) should = 90 mv or 3 dots.
4. Gen from 10uv to 10,000 uv (LOC Center) needle should not vary over 1 mv.
5. Gen to 3 uv, should have full NAV flag.
6. Gen to 1000uv 90hz only or 150 hz only. Should have flag showing.

**Digital Bearing Indicator alignment.**

1. If digital bearing indication is more then 1 degree in error, apply standard VOR signal at 240 degrees.
2. Adjust A5R7 Radial Zero, while rocking generator output, to center radial reading at 60 degrees.
3. Gen to uv, unit should show dashes. At 3 uv and higher, unit should show radial.

**Common Part Numbers; Part Numbers Not In The Manual:**

Displays: 262-1390-010      Lens, Polarized: 628-5321-001

**Common Part Numbers That Have Changed:**

<b>Symbol</b>	<b>Old P/N</b>	<b>S-TEC P/N</b>
A3L1	240-2741-020	240-0988-080
A3U7	351-1549-010	No longer avail.
A3CR101	353-3264-020	922-6131-020
A6Q2	352-5016-010	352-1045-030
A6CR1/3/5/7	353-3264-020	922-6131-020
A6L1/2/4/5	628-5448-002	278-0415-020

## COMMON PROBLEMS AND FIXES COURTESY OF S-TEC CUSTOMER SERVICE

I. +5, -12VDC power supply common problems: No +5VDC or -12VDC. Usually can be repaired by replacing A2U1. No -12VDC only. Usually A2CR2.

II. Noisy audio common problems: Synthesizer VCO frequency drifting. If tuning voltage is correct, the problem usually lies with A3L1 (39mh coil).

III. Nervous VOR needle common problems: (A) Detector signal oscillating. Realign receiver for maximum AGC according to alignment procedures in manual. Then at 47 DBM, set R39 to 1.4VDC on the case of Q3. Set R29 detector for .5VRMS. Repeat AGC delay (R39) and detector level adjustment (R29) until results are met. Then connect oscilloscope to A6TP3 and observe detector signal. Adjust C23 until detector signal just stops oscillating. Go back and verify 4.5VDC AGC voltage at 97.5 DBM on gen.

(B) A.C. ripple on 10VDC line at junction of A6R108 and A6R113. While looking at junction with oscilloscope, verify AC ripple increases and decreases while adjusting volume knob. Fix: Usually A6C109 and/or A6R113 bad. (C) If not step (B) above, check A.C. ripple at A4VR1 and A4VR2 on VOR converter board. Ripple here usually means VR1 and VR2 have been changed and the impedance of the new zeners are causing this A.C. ripple.

IV. VOR needle will not adjust to center. Common problem: Needle shifts left or right of center and will not stay centered. Check 70 u sec. neg. going pulse width at TP2, ensure it does not self-oscillate when R22 is adjusted to both ends of its range. Fix: If 70 u sec. neg. going pulse width self-oscillates, replace A4U2. If 70 u sec. neg. going pulse width is good, replace chopper A4Q1.

V. NAV channeling. The VIR-351 switching unit utilizes BCD and 2x5 control logic. The 2x5 runs straight from the switches to the rear connector. The nav unit uses BCD information for itself. The BCD logic runs straight to the rear connector and from the rear connector to A5 LOC/PWR sup board, from the A5 board through A5-U4, then off the board to the front display (A1 board). Common problem: NAV1 channels TCR-451 and NAV2 channels some frequencies but not all. NAV1 seems to effect NAV2 2x5 channeling or vice-versa. Fix: Once you verify DME NAV select lines and aircraft wiring are correct, then you probably have a bad isolation diode in the NAV unit itself on the 2x5 switches. (Note: You cannot have a BCD external short problem without seeing it on the NAV display.)

NOTES: