

# NARCO AVIONICS

## AT 150 TSO Transponder

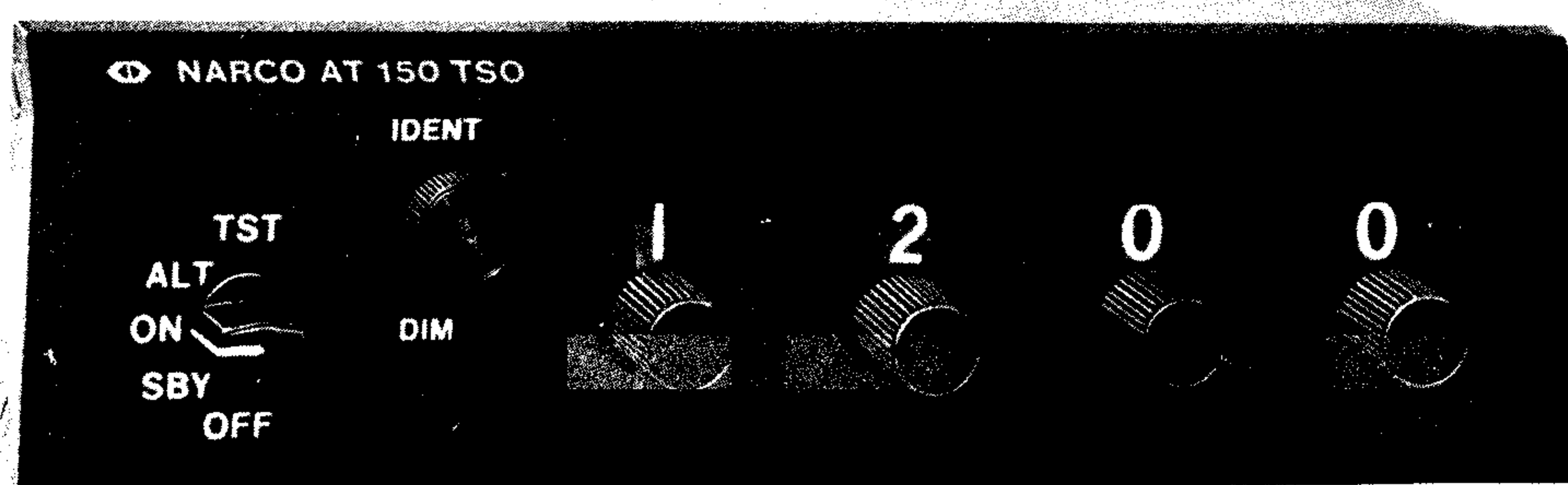

### INSTALLATION MANUAL

03606-0620



**NARCO AVIONICS**

FORT WASHINGTON, PENNSYLVANIA, 19034 U.S.A.

DECEMBER, 1976

© 1977  
NARCO SCIENTIFIC INDUSTRIES, INC.

Printed in U.S.A.  
Reprint 8/80

## 2.1 INTRODUCTION

This section provides the necessary information for the installation of the AT 150 TSO and, where required, optional accessories. The mechanical and electrical sections are self-supporting and may be removed from the manual to permit the mechanical and electrical installation efforts to proceed simultaneously.

## 2.2 PRELIMINARY INSPECTION

### 2.2.1 Unpacking

Carefully unpack the Unit and inspect it for any damage that may have occurred during shipment. Refer to Section 1.5, Units and Accessories Supplied, and inventory the contents of the Installation Kit. Refer to Section 1.7, Miscellaneous Items Required but NOT Supplied for a listing of items and equipment needed for proper installation.

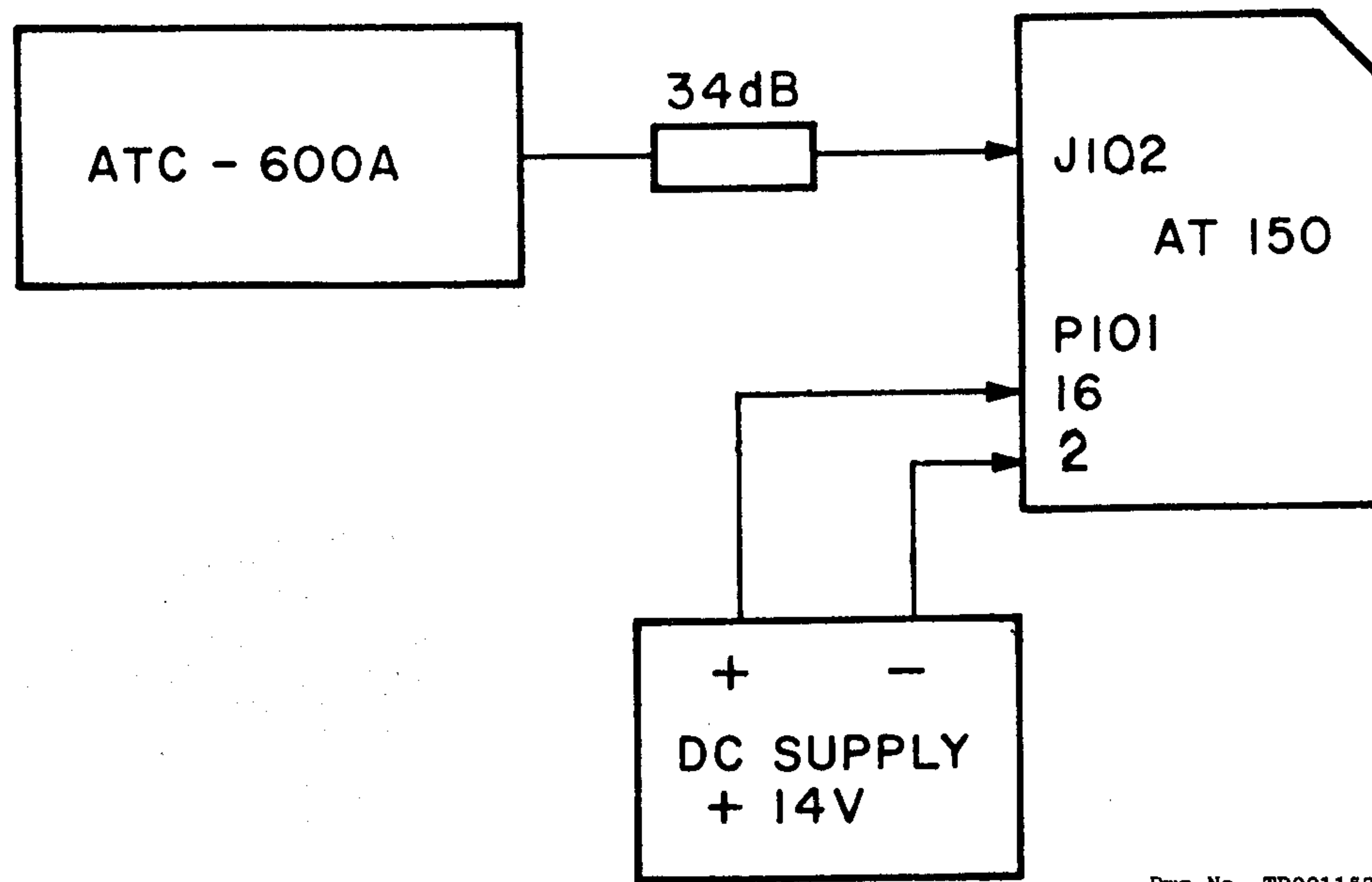

FIGURE 2-1. BENCH TEST SET-UP

### 2.2.2 Electrical Bench Test

#### 2.2.2.1 Test Equipment Required

- A. Transponder and DME Test Set: IFR Model ATC-600A or equivalent.
- B. 34 dB attenuation pad.

#### 2.2.2.2 Test Procedure

##### A. Set-Up

- 1. The AT 150 should be tested while contained in the mounting tray with the RF cable installed.
- 2. When the AT 150 is being interrogated by the ATC-600A, the IDENT/DIM button will blink ON and OFF.

##### B. Receiver Sensitivity

- 1. Place the AT 150 in the ON mode. Place the ATC-600A in the A/C CODE mode.
- 2. Rotate the ATC-600A XPDR SIG. level control full counterclockwise. The % scale of the XPDR RPLY meter should read 100%.
- 3. Rotate the XPDR SIG level control clockwise until the XPDR RPLY meter reads 90%.
- 4. The XPDR SIG level control indicator should be between -69 and -73 dBm. This is the MTL of the transponder.

2.2.2.2 Continued

5. Repeat steps 2, 3, and 4 with the AT 150 in the ALT mode and the ATC-600A in the A/C ALT mode. The difference between the MTL readings should not be greater than 1 dBm.
- C. SLS (Side-Lobe Supression)
1. Place the AT 150 in the ON mode. Place the ATC-600A in the A/C CODE mode.
  2. Rotate the XPDR SIG. level control full counterclockwise. The XPDR RPLY meter should read 100%.
  3. Set the XPDR SIG. level control to 3 dB above MTL (level established in step B-4).
  4. Set the SLS switch to 0 dB. The XPDR RPLY meter should read zero.
  5. Set the SLS switch to 9 dB. The XPDR RPLY meter should read 90% minimum.
- D. Code Selection
1. Place the AT 150 in the ON mode. Place the ATC-600A to the A/C CODE mode.
  2. The ATC-600A numerical display should display the code selected by the AT 150 Code Selector switches. Several different codes should be selected.
  3. Consider the AT 150 Code Selector switches to be labeled A, B, C, and D. Switch A should light the ATC-600A Binary Readout lamp  $A_1$  when it is in the 1 position, the  $A_2$  lamp in the 2 position, and the  $A_1$  and  $A_2$  lamps in the 3 position. In each switch position, the sum of the subscripts of the Binary Readout lamps that light should equal the number selected.
  4. Repeat the above procedure for switches B, C, and D.
- E. Transmitter Frequency
1. Place the AT 150 in the ON mode and set the Code Selector switches to 0000.
  2. Place the ATC-600A in the A/C CODE mode and set the POWER/FREQ switch to FREQ.
  3. Adjust the GAIN control for a mid-scale reading on the POWER meter.
  4. Rotate the XMTR FREQ control for a peak indication on the POWER meter.
  5. At peak, read the deviation from 1090 MHz directly from the XMTR FREQ control dial. The deviation should be no greater than  $\pm 3$  MHz.
- F. Transmitter Power
1. Place the AT 150 in the ON mode and set the Code Selector switches to 6050.
  2. Place the ATC-600A in the A/C CODE mode and set the POWER/FREQ switch to POWER.
  3. Read 250 watts on the POWER meter.
- G. IDENT
1. Place the AT 150 in the ON mode. Place the ATC-600A in the A/C CODE mode.
  2. Momentarily depress the IDENT/DIM button on the AT 150.
  3. The AT 150 IDENT/DIM button and the ATC-600A IDENT lamp should glow for approximately  $20 \pm 5$  seconds.



2.2.2.2 Continued

H. Altitude Digitizer Inputs

The following procedure is a functional check of the Altitude Digitizer Inputs P101-6 through P101-14 only. Therefore, the numerical readout and INVALID ALT lamp on the ATC-600A should be ignored.

1. Place the AT 150 in the ALT mode. Place the ATC-600A in the A/C ALT mode.
2. Placing an Altitude Digitizer Input at ground potential will activate a corresponding Binary Readout lamp on the ATC-600A. Table 2.1 lists the P101 pin numbers and their corresponding ATC-600A Binary Readout lamps.

TABLE 2.1 ALTITUDE DIGITIZER INPUTS

GROUND P101-	ACTIVATE ATC-600A BINARY READOUT LAMP
6	A <sub>2</sub>
7	A <sub>1</sub>
8	A <sub>4</sub>
9	B <sub>4</sub>
10	B <sub>2</sub>
11	C <sub>2</sub>
12	B <sub>1</sub>
13	C <sub>4</sub>
14	C <sub>1</sub>

- I. Disconnect the transponder from the Test Set-Up.

## 2.3 MECHANICAL INSTALLATION

### 2.3.1 Mounting Tray

The AT 150 is supplied with a mounting tray which is designed to mount behind the aircraft instrument panel using four number 6 screws. Figure 2-2 provides a detailed drawing of the tray and the parts of the Installation Kit. This figure also provides all the necessary dimensions for the panel cutout as well as dimensions for mounting brackets locations. A full scale cutout template is also provided.

Mounting brackets (4) are not supplied due to the wide range in mounting requirements. Suitable mounting brackets may be fabricated from ordinary sheet metal or angle stock.

To ensure a sturdy mount, rear support for the unit should be provided.

### 2.3.2 Insertion And Removal Of The AT 150

Before inserting the AT 150 into the tray, refer to paragraph 2.5.4 and check that the PILOT LAMPS have been wired properly.

The AT 150 is secured to the mounting tray by an allen head ramping screw running from the front panel to the rear of the unit and a self-locking nut attached to the tray rear panel. The access hole for the ramping screw is located on the front panel below the IDENT/DIM button (see Figure 1-1).

Slide the Unit straight into the tray until the ramping screw contacts the self-locking nut. Using a 3/16" allen wrench, turn the screw clockwise until the mating connector is engaged and the unit is firmly secured in the tray.

**DO NOT RAM THE UNIT INTO THE TRAY OR OVER TIGHTEN THE RAMPING SCREW.**

To remove the unit, turn the ramping screw counterclockwise until it is clear of the self-locking nut and then pull the unit straight out.

INSTALLATION KIT (03804-0500)

Item	Part Number	Description	Qty
1	81213-0034	SPACER	2
2	41316-0009	CONNECTOR, 18 pin (Molex)	1
3	41317-0001	CONTACT, Crimp type	24
4	82802-0005	WASHER, Lock, Int. Tooth, #6	4
5	82900-0008	NUT, Hex, 6-32	4
6	81324-0004	WASHER, Lock, Split, #4	2
7	82814-0004	SCREW, Blind Hd, 4-40 x 5/16	2
8	82815-0005	SCREW, Blind Hd, 6-32 x 3/8	4
9	41152-0005	CONNECTOR, BNC	2
10	99090-0001	PAD, Spacer	4

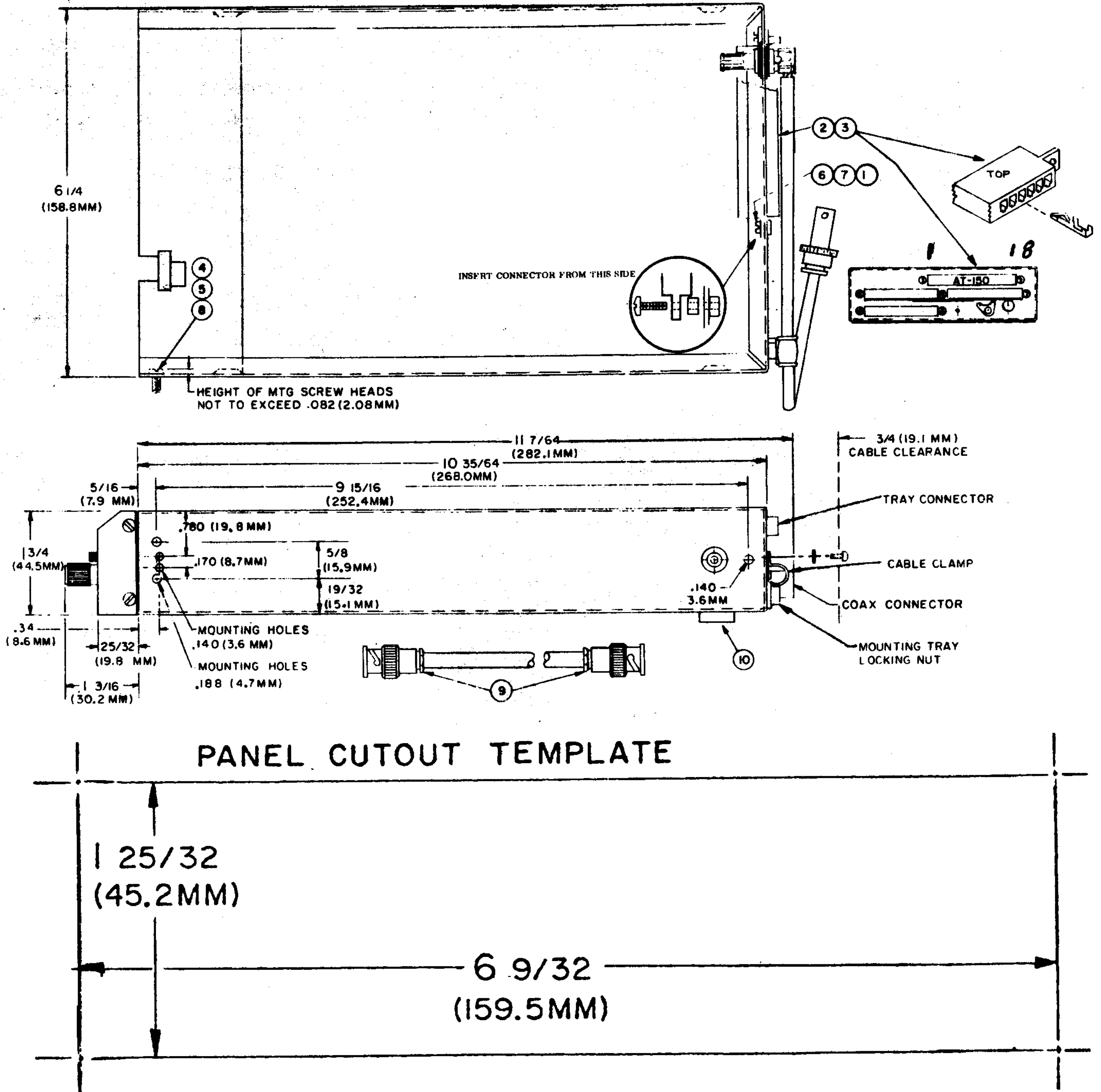

FIGURE 2-2. INSTALLATION DIAGRAM



## 2.4 ANTENNA INSTALLATION

### 2.4.1 Antenna Location And Mounting

The AT 150 Antenna supplied in the Installation Kit should be mounted on the bottom surface of the aircraft and located such that it will be in a vertical position when the aircraft is in level flight. The area surrounding the antenna location should be free of protrusions which could interfere with the line-of-sight characteristics of a VHF signal. The following rules should be observed with regard to the ground plane.

#### A. Metallic Mounting Surface

Mount the antenna in the center of a 6" (152.4 mm), minimum radius, ground plane. Antenna located near the edge of a ground plane may cause holes in the radiation and reception patterns.

#### B. Non-Metallic Mounting Surface

Aircraft with fabric, wood, or fiberglass fuselage covering must have a metal ground plane with a 6" (152.4 mm) minimum radius. This could be as simple as aluminum foil cemented inside wood or stiff fiberglass skin, or a doubler plate on a fabric covered aircraft. Such a ground plane should be either well bonded to the airframe, or well insulated from it, to prevent noise problems or erratic operation. Antenna mounting hardware must electrically connect the ground plane to the antenna.

A doubler plate will be needed for an airworthy installation on most aircraft. Check the airworthiness regulations of the country of aircraft registry for acceptable mounting methods.

Figure 2-3 illustrates the antenna mounted and the necessary minimum clearances. Remove all oxidation, paint, or other finish to permit good electrical contact between the antenna base and the aircraft. Electrical ground will be carried by the mounting hardware.

**DO NOT PAINT.** The antenna should not be painted or coated with any other finish.

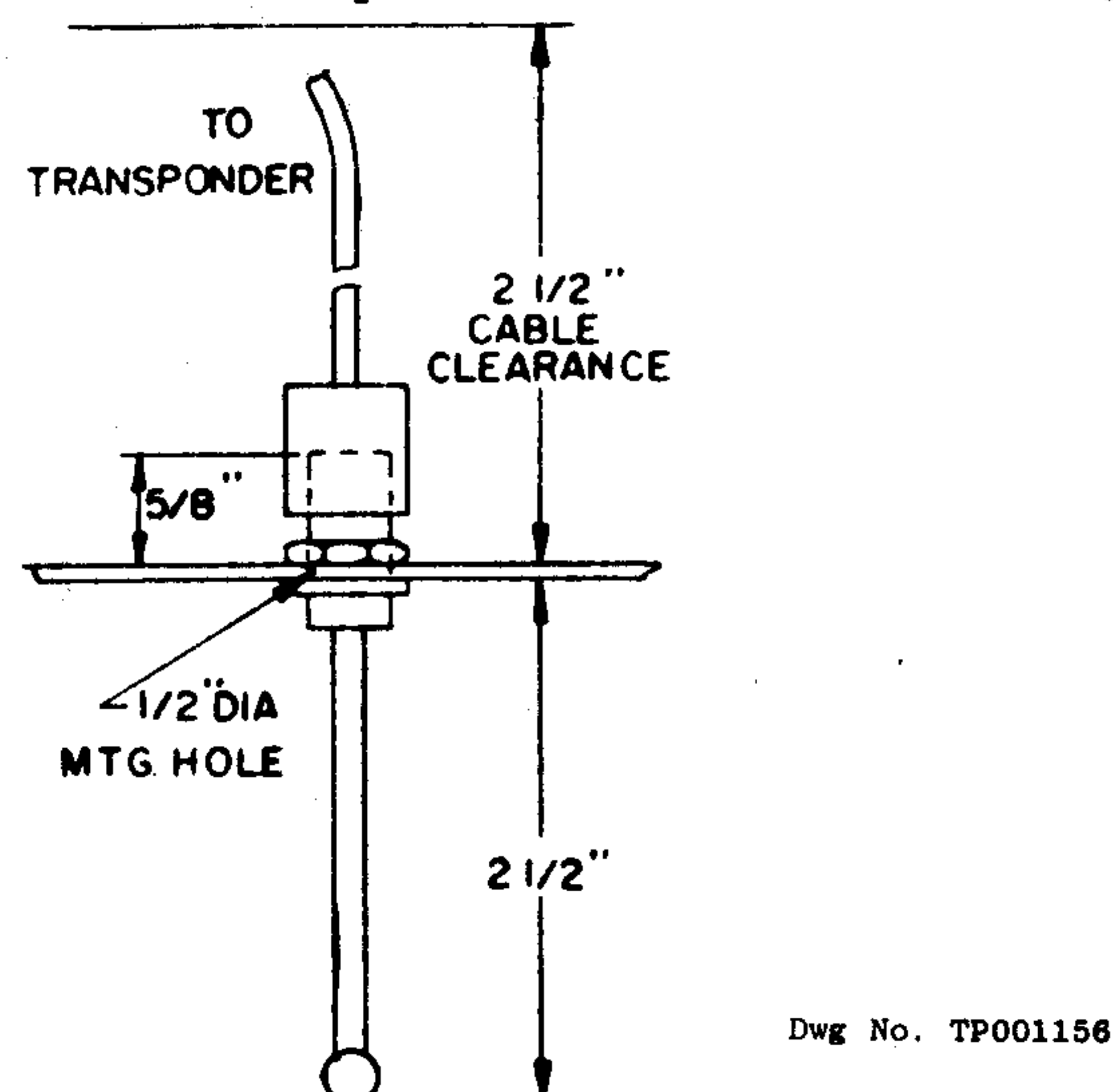

FIGURE 2-3. AT 150 ANTENNA MOUNTING



#### 2.4.2 Antenna Extension Cable

The Installation Kit provides two UG-88U BNC connectors for fabrication of the antenna extension cable. The total length of this cable should not exceed 9 feet (2.7m). Should a cable of greater length be required, a coaxial cable type should be selected whose attenuation does not exceed 2 dB over the entire length.

Narco makes available eight and nine foot low loss extension cables, complete with factory-installed BNC connectors; order Part Number 90624-0096 (8 foot) or Part Number 90624-0108 (9 foot).

2.5 ELECTRICAL INSTALLATION

2.5.1 Power And Interconnect Cable

The Installation Kit provides an 18 pin Molex connector along with sufficient pins for fabrication of the power and interconnect cable. Figure 2-4 presents the electrical connections and Figure 2-5 presents a system orientation diagram.

All signal leads should be 22 AWG. A+ and ground leads should be 16 AWG. The ground lead should be connected directly to airframe ground.

A 1.5 amp circuit breaker should be provided between the unit and the aircraft power bus.

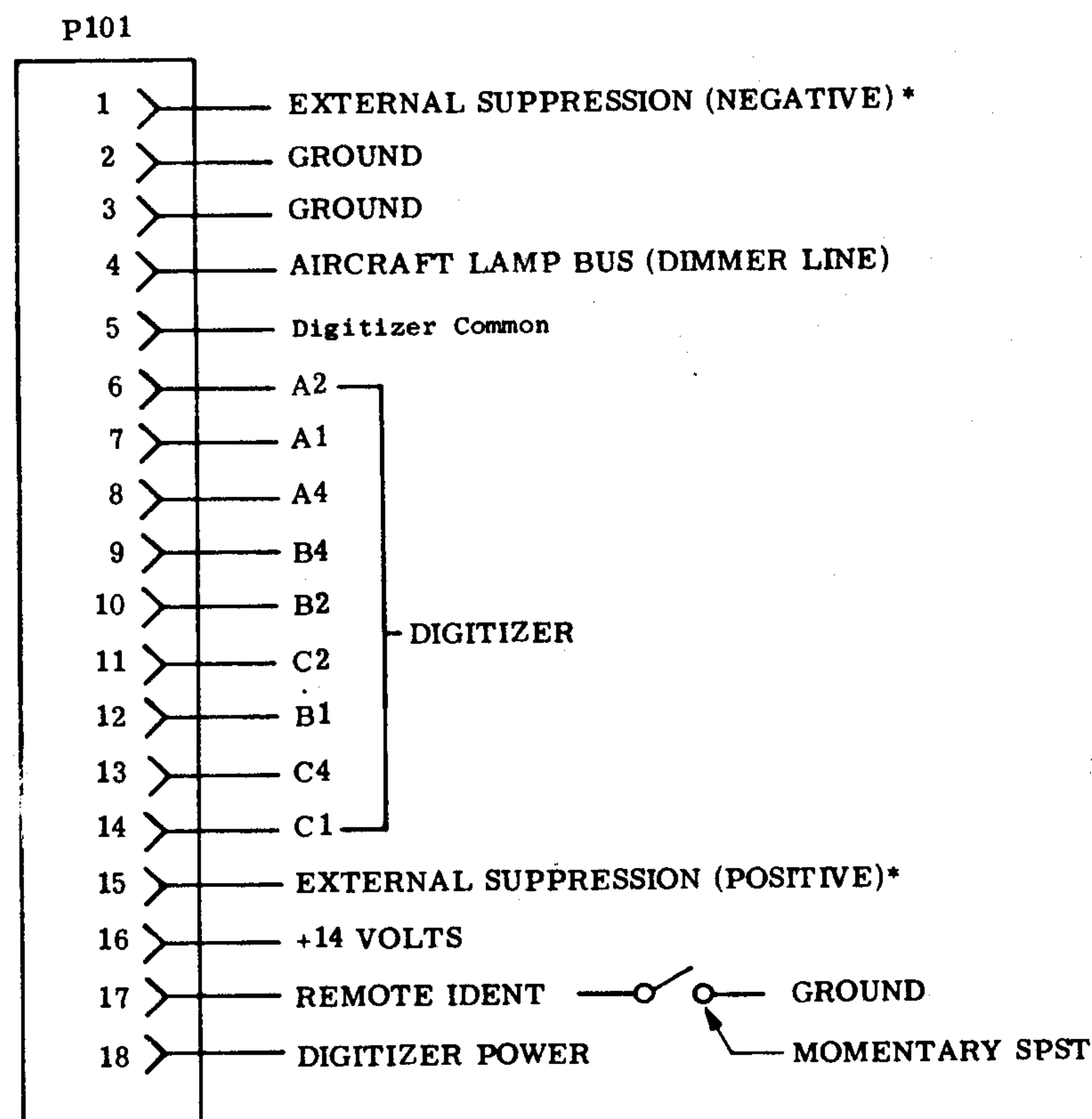

\*TRANSMISSION MAY BE SUPPRESSED BY EITHER:  
a) GROUNDING PIN 1 OR b) APPLYING A POSITIVE  
VOLTAGE TO PIN 15

Dwg No. TP001158A

FIGURE 2-4 POWER AND INTERCONNECT CABLE

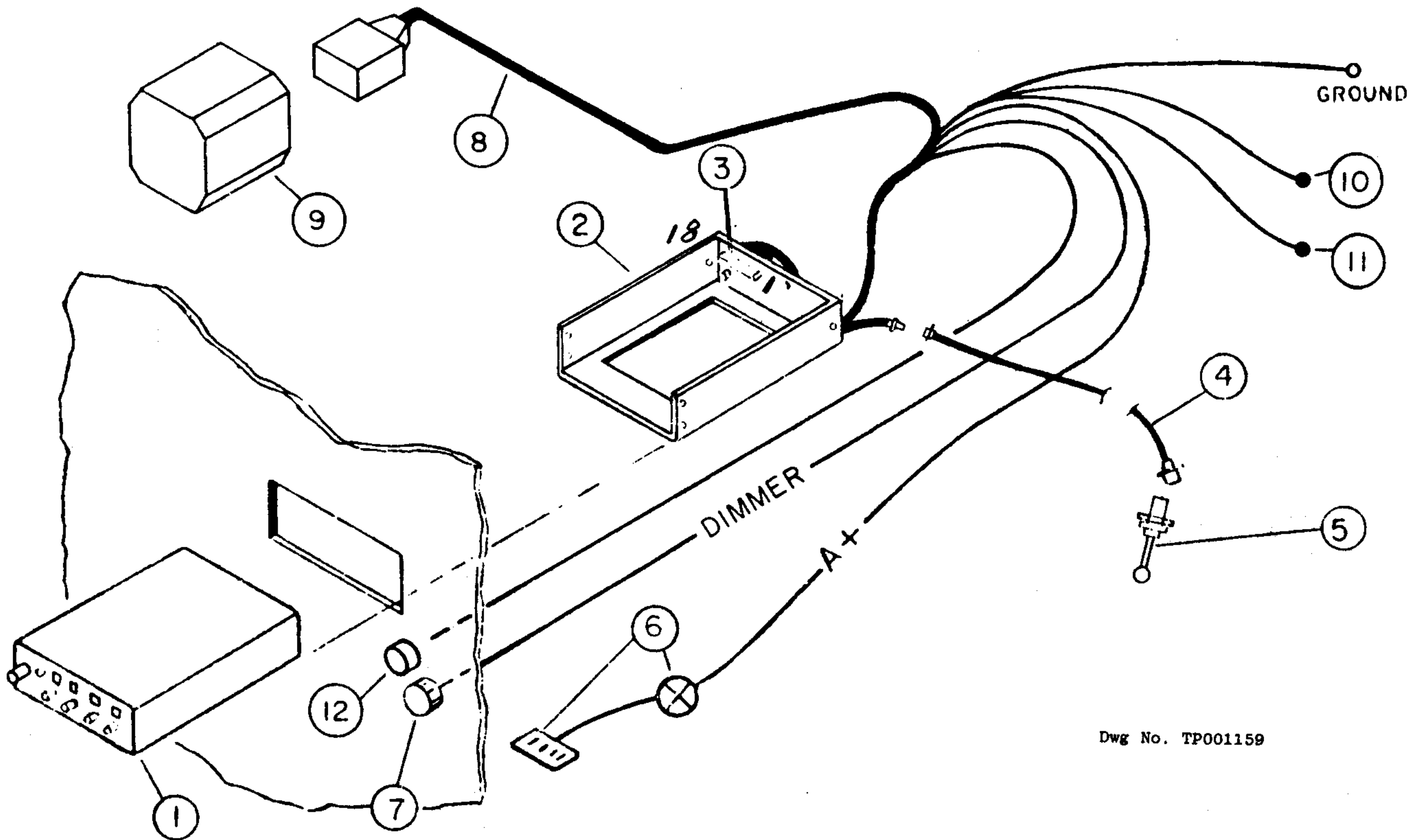

- |  |                              |
|--|------------------------------|
| 1. Transponder                           | 7. Panel Lamp Dimmer         |
| 2. Mounting Tray with Antenna Cable Assy | 8. Altitude Digitizer Cable  |
| 3. Power Connector                       | 9. Altitude Digitizer        |
| 4. Antenna Cablé Extension               | 10. External Suppression (+) |
| 5. Antenna                               | 11. External Suppression (-) |
| 6. Power Supply Bus and Circuit Breaker  | 12. Remote IDENT             |

FIGURE 2-5. ORIENTATION DIAGRAM



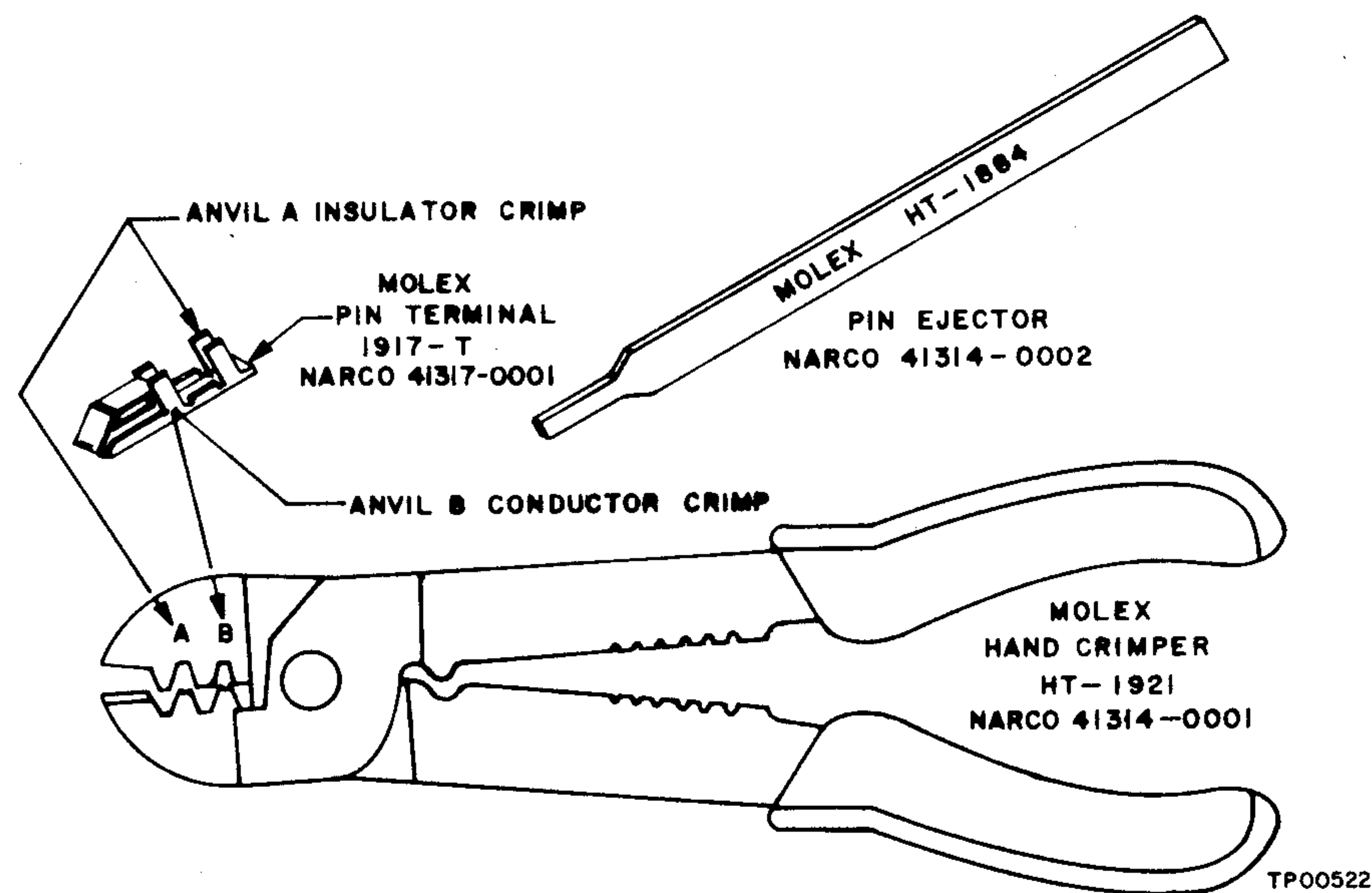

FIGURE 2-6. CRIMPING TOOL

### 2.5.2 Cable Fabrication

1. Strip wire  $5/32$ " for PIN Terminal No. 1917-T.
2. Open tool (engraved side toward you), from the opposite side, place the conductor tab section of the pin on Anvil B. Close tool slightly (until the tabs touch the female jaw).
3. Insert stripped conductor until insulation is level with outside of jaw. Crimp by squeezing handles together until jaws are fully closed or sufficient crimp is made.
4. Move lead and pin to Anvil A. Crimp again until jaws are closed or sufficient crimp is made.
5. If necessary, straighten pin while still being held in the jaw.

### Insertion

1. The PIN terminal may now be inserted into the desired pin location in the translucent connector housing. The pin cannot be inserted upside down. Right-side-up it slides in effortlessly. Be sure to push it all the way in, until a "click" can be felt, heard, or even seen (by turning the translucent housing over).
2. There is no necessity to pull back on the lead itself except to test for the "locking feature", and then only with a moderate pull.

### 2.5.2 Continued

#### Extraction

1. If a pin is erroneously inserted into the wrong housing position, or if at some later time a circuit change is desired, the pin can be removed easily. Slip the flat narrow blade portion of the tool into the mating side of the housing, under the pin. By holding the housing upside down one can see the blade slide in, up to the stop. This action picks up the locking key and allows the lead and pin to slip out of its position using a light pulling action on the lead. Neither pin nor position has been damaged allowing re-insertion in the same or another position.

#### Crimping with Pliers

The lead PIN Terminal connection using the Molex hand crimper provides a superior connection than with pliers. However, with care, a satisfactory connection can be made without the crimper.

1. Strip wire 5/32" for PIN Terminal 1917-T.
2. Using needle nose pliers, fold over conductor tabs firmly onto the conductor, one side then the other.
3. Repeat step 2 for the insulator tabs.

### 2.5.3 28 Vdc Operation

The AT 150 has been designed for 14V operation. Installation in aircraft with 28V electrical systems will require the addition of the external voltage converter, Model MP 10. Refer to Systems paragraph 1.10 for installation details.

2.5.4 Pilot Lamps

Pilot Lamp 14/28v Switch

Commencing with AT 150 Chassis Level Code JB do not change the pilot lamp jumpers!

These Units contain an external 14/28 vdc switch for this purpose. The switch, for proper lamp brilliance, should be set to agree with that of the aircraft's bus voltage.

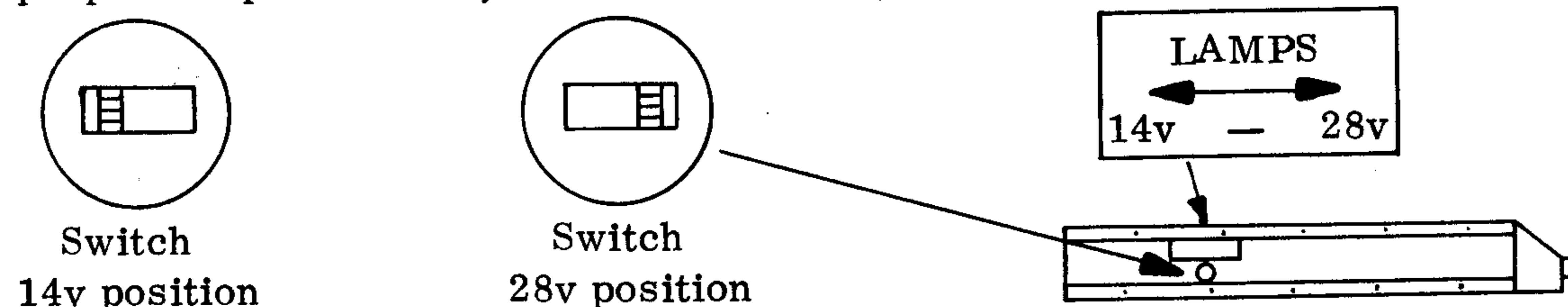

FIGURE 2-7. PILOT LAMP CONVERSION (SWITCH)

Pilot Lamp 14/28v Jumpers (Units without external switch.)

The AT 150 pilot lamps are factory wired for 14v operation. Installation in aircraft with 28v electrical systems will require that the lamp circuitry be wired in series. To connect the lamp circuit for 28v operation, refer to Figure 2-8 and proceed as follows:

- A. Remove the rear cover and then remove the bottom cover.
- B. Unsolder the jumper wire between E415 and E413 and the jumper wire between E414 and E412.
- C. Solder a jumper wire between E412 and E413.
- D. Replace the bottom cover and then replace the rear cover.

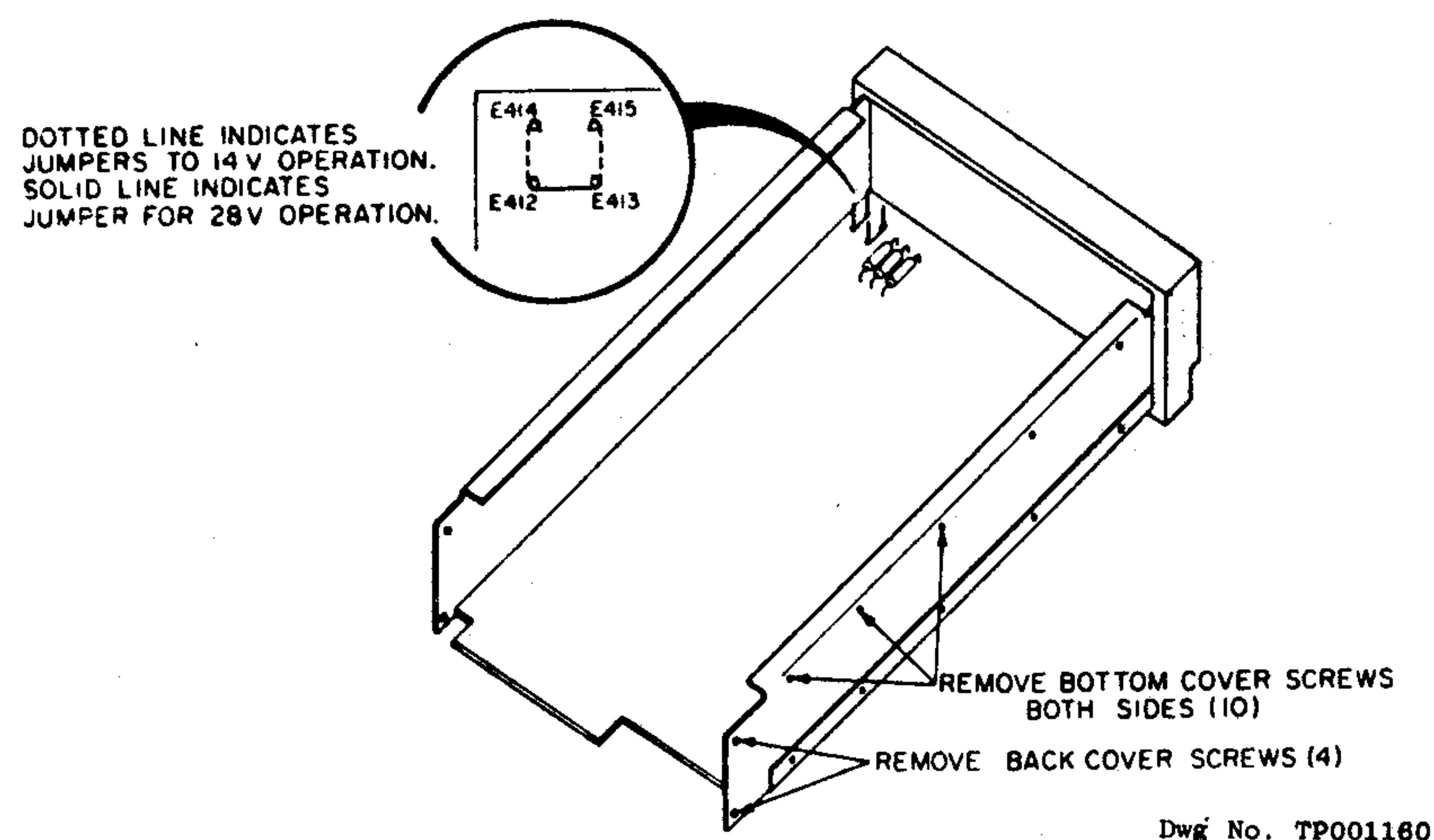

FIGURE 2-8. PILOT LAMP CONVERSION (JUMPERS)



## NARCO AVIONICS AT 150

### 2.5.5 External Suppression

The AT 150 transponder may be externally suppressed by other avionics equipment whose transmissions may be interfered with by simultaneous AT 150 transmissions. P101-15 may be connected to equipment that supply positive suppression pulses. P101-1 may be connected to equipment that supply negative suppression pulses.

In aircraft equipped with dual transponders, P101-1 of both transponders may be connected to a remote SPDT switch which will alternately suppress the transponders by placing the appropriate P101-1 at ground potential. This switch may be located at any convenient place in the cockpit and labeled appropriately.

### 2.5.6 Remote IDENT

P101-17 provides for the connection of remote IDENT switch. This switch should be a momentary SPST type and connected such that activation places P101-17 at ground potential. This switch may be located at any convenient place in the cockpit and labeled appropriately.

### 2.5.7 Altitude Digitizer

P101 pins 5 through 14 provide for the connection of an altitude digitizer. The altitude digitizer, sensing atmospheric pressure, converts pressure/altitude information into digitized altitude data. This data is then transmitted to the control center by the transponder. Narco recommends the Model AR 500 for this application.

## 2.6 POST INSTALLATION TESTS

To certify the installation, FAA Form 337 must be completed. In addition, weight and balance or any operating limitations must be entered into the aircraft logbook. Refer to the current Federal Aviation Regulations for any additional requirements.

Weight	2.3 lbs (1.04 kg)
Power Requirements	1.0 Amperes, Receive
	1.6 Amperes, Transmit
	0.26 Amperes, Pilot Lamps

### 2.6.1 Preflight Tests

A preflight test should be performed using an ATC-600A Transponder and DME test set or equivalent. The test set should be set-up as described in the ATC-600A Operators Manual and following tests should be conducted:

1. Pilot Code
2. Peak Transmitter Power
3. Transmitter Frequency
4. SLS Operation
5. IDENT
6. Percent Reply

In the event that an altitude digitizer has been installed, the altitude digitizer manual should be consulted for proper procedures and the following tests should be conducted:

1. Altitude Code
2. Invalid Altitude Code Output

### 2.6.2 Flight Test

After installation, a flight test should be performed to check overall operation and system compatibility.

#### A. Range Test

The AT 150 should furnish a strong and stable return signal to an interrogating radar facility that is 50 NM away when the aircraft is flying at 6000 feet. At this altitude and distance, fly a flat circle while having an FAA station monitor the transponder return signal. There should be no more than two sweeps of the interrogating radar without a return response.

#### B. Surveillance Approach

Perform an approach to a runway of an airport starting at least 10 NM from the airport served by Airport Surveillance Radar (ASR) having an Air Traffic Control Radar Beacon System (ATCRBS) facility. Alternately, a simulated approach and letdown may be made along a path parallel to, but separated, three to four miles from a vertical plane through the location of the ASR facility. The approach should be made at the normal rate of descent and normal approach and landing configuration for the aircraft and should continue down to an altitude of 200 feet. Not more than one "drop out" should occur for any 10 radar sweeps during final approach.

#### C. Electromagnetic Compatibility

The transponder should not cause the performance of other systems aboard the aircraft to be degraded below their normal capability and transponder operation should not be adversely affected by other equipment.

## 2.7 AIRCRAFT LICENSE REQUIREMENTS

The AT 150 TSO, as installed in the aircraft, requires an Aircraft Radio Station License. This license may be obtained by filing FCC Form 404. The unit may be operated for up to 30 days after filing the FCC Form 404 providing a copy of the FCC Form 404 is kept in the aircraft.

This equipment has been type accepted by the FCC and entered in their list of type accepted equipments as "NARCO AT 150 TSO".