

Narco Avionics

AT165 TSO Transponder

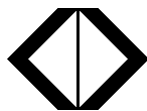

Installation Manual 03609-0620



Narco Avionics Inc.
270 Commerce Drive, Suite 200
Ft. Washington, Pa. 19034
U.S.A.

NOTICE

While every effort has been made by Narco Avionics Inc. to ensure accuracy in the preparation of this Installation Manual, Narco assumes no responsibility for errors or omissions

Narco Avionics can be reached by calling :

Phone : 215-643-2900

FAX : 215-643-0197

Or on the Internet at www.narcoavionics.com

The AT165 is dedicated to John Bail (1929-2003). John , as Vice President of Engineering and later as a consultant, was instrumental in the development of many of Narco's best selling products including the AT165.

Narco Avionics AT165 TSO
TABLE OF CONTENTS

SECTION NUMBER	TITLE	PAGE NUMBER
1.1	GENERAL	1-1
1.1.1	Manual Organization	1-1
1.2	PRODUCT DESCRIPTION	1-1
1.3	PRODUCT SPECIFICATIONS	1-2
1.4	TSO EXPLANATION	1-3
1.4.1	AT165 Antenna	1-3
1.5	UNITS AND ACCESSORIES SUPPLIED	1-3
1.6	OPTIONAL ACCESSORIES	1-4
1.7	MISCELLANEOUS ITEMS REQUIRED BUT <u>NOT</u> SUPPLIED.	1-4
1.8	OPERATOR LICENSE REQUIREMENTS	1-4
1.9	OPERATION	1-5
1.9.1	Function Selector Switch	1-5
1.9.2	CODE SELECTOR/DATA ENTRY	1-6
1.9.3	IDENT	1-6
1.9.4	VFR	1-6
1.9.5	HOLD	1-6
1.9.6	FUNC	1-7
1.9.7	START/STOP	1-7
1.9.8	CRSR/CLR	1-7
2.1	INTRODUCTION	2-1
2.2	PRELIMINARY INSPECTION	2-1
2.2.1	Unpacking	2-1
2.2.2	Electrical Bench Test.	2-2
2.2.2.1	Test Equipment Required.	2-2
2.2.2.2	Test Procedure	2-2
2.3	MECHANICAL INSTALLATION.	2-5
2.3.1	Mounting Tray	2-5
2.3.2	Insertion And Removal Of The AT165	2-5
2.4	ANTENNA INSTALLATION	2-7
2.4.1	Antenna Location And Mounting.	2-7
2.4.2	Antenna Extension Cable.	2-8
2.5	ELECTRICAL INSTALLATION	2-9
2.5.1	Power And Interconnect Cable	2-9
2.5.2	Cable Fabrication	2-11
2.5.3	Pilot Lamps	2-12
2.5.4	External Suppression	2-12
2.5.5	Remote IDENT	2-13
2.5.6	Altitude Digitizer	2-13
2.6	POST INSTALLATION TESTS	2-13
2.6.1	Preflight Tests	2-13
2.6.2	Flight Test	2-14
2.7	AIRCRAFT LICENSE REQUIREMENTS.	2-14
	APPENDIX A – CERTIFICATION DOCUMENTS	
A.1	ENVIRONMENTAL QUALIFICATION FORM	A-1
A.2	CONTINUED AIRWORTHINESS	A-2
R.1	MANUAL REVISION HISTORY	R-1

LIST OF ILLUSTRATIONS

FIGURE NUMBER	TITLE	PAGE NUMBER
1-1	AT165 TSO FRONT PANEL	1-5
2-1	BENCH TEST SET-UP	2-2
2-2	INSTALLATION DIAGRAM	2-6
2-3	AT165 ANTENNA MOUNTING	2-7
2-4	POWER AND INTERCONNECT CABLE	2-9
2-5	ORIENTATION DIAGRAM	2-10
2-6	CRIMPING TOOL	2-11

LIST OF TABLES

TABLE NUMBER	TITLE	PAGE NUMBER
1.1	UNITS AVAILABLE	1-3
1.2	INSTALLATION KIT (3604-0500)	1-4
2.1	ALTITUDE DIGITIZER INPUTS	2-4

1.1 GENERAL

In support of the Narco Avionics AT165 TSO Transponder, this manual provides detailed installation and operation procedures.

"This manual is intended for use only by persons qualified to install equipment in this manual pursuant to current regulatory requirements."

1.1.1 Manual Organization

Organized into two major sections the manual includes the following:

Section 1, Introduction - general information required in planning the installation

Section 2, Installation - detailed procedures for performing the mechanical and electrical installation

1.2 PRODUCT DESCRIPTION

The AT165 TSO is a panel-mounted transponder with additional altitude and timing functions. The AT165 consists of a receiver tuned to the frequency of a ground interrogation station (1030 MHz), logic circuitry to check the validity of the received interrogation and encode a reply containing pertinent identification information, and a transmitter which sends the coded reply to the ground station. When connected to an optional Altitude Digitizer (AR850) coded altitude information will be transmitted to the ground station.

The AT165 utilizes a single knob for error free code entry even in turbulence. Push button controls are used to access and manipulate the added features. The front panel display has two distinct areas, one for the primary transponder functions and the second for the altitude and timing functions.

The AT165 has been designed for 14V or 28V operation. If the AT165 is replacing an existing AT50A, AT150, or AT155 that uses an MP10 or a passive voltage converter these do not have to be removed.

1.3 PRODUCT SPECIFICATIONS

Mechanical

Physical Dimensions and Mounting Refer to appropriate diagram in Section 2
 Weight 1.7lbs. (0.77kg)

Electrical

Power Requirements	13.75 VDC	27.5VDC
Standby	575mA	460mA
Transmit	1.75 A	880mA
OFF (Pilot Lamps)	260mA	260mA
Dimmer Buss	14µA	28µA

Receiver

Frequency 1030 MHz
 Sensitivity Minimum trigger level (MTL) -69 to -74 dBm
 Side-Lobe Suppression (SLS) 99% or greater for signals from 3 dB to 50 dB above MTL
 Dynamic Range Logarithmic pulse response 50 dB or greater above MTL
 Bandwidth -60dB at ± 25 MHz

Decoding Capability

Mode A Pulse pair spaced at 8 ±0.5µs
 Mode C Pulse pair spaced at 21 ±0.5µs

Side-Lobe Suppression

35 µs suppression upon receipt of two pulses spaced 2 ±0.5µs apart.

Encoding Capability

Mode A 4096 reply codes selectable by front panel switches.
 Mode C Altitude reporting to 30,700 feet
 SPIP (Special Position Identification Pulse) An SPIP may be added to mode A for 20 ±5 seconds

Transmitter

Frequency 1090 MHz
 Pulse Power 250 watts nominal, 190 watts minimum

External Interference Suppression (positive)

Pulse Amplitude 5 to 50 volts
 Load on Suppressor 3300 ohms

External Interference Suppression (negative)

Voltage 0.8V (maximum)
 Current 5 mA

1.4 TSO EXPLANATION

The TSO'd AT165 is designed to be instrument panel mounted within the cabin environment of fixed and rotary wing aircraft using piston or turbine single or multi-engines. It will operate and has been tested up to 30,000 feet for installations in non-pressurized as well as pressurized aircraft. This equipment requires direct current power but is designed to be installed in aircraft that have additional on board alternating current sources. Environmental testing was done to RTCA Document DO-160C. The Environmental categories are listed in Appendix A of this document.

1.4.1 AT165 Antenna

The AT165 Antenna meets the requirements of TSO-C74b Class 1, Environmental Category /JA/JAAAXXXXXX.

1.5 UNITS AND ACCESSORIES SUPPLIED

The following two tables may be used to: 1) check the contents of your order and, 2) to order additional Units or components.

TABLE 1.1 UNITS AVAILABLE

Unit Part Number	Unit and Description	Subassembly Part Number
03609-0300	AT165 TRANSPONDER ASSY, Complete with: AT165 Transponder, Tray Assy Antenna Assy Installation Kit	01550-0101 56282-0102 71233-0101 03604-0500

TABLE 1.2. INSTALLATION KIT (03604-0500)

Item	Part Number	Description	Qty
1	81213-0034	SPACER	2
2	41316-0009	CONNECTOR, 18 pin (Molex)	1
3	41317-0001	CONTACT, Crimp type	24
4	82802-0005	WASHER, Lock, Int. Tooth, #6	4
5	82900-0008	NUT, Hex, 6-32	4
6	82969-0004	WASHER, Lock, Split, #4	2
7	82814-0004	SCREW, Bind Hd, 4-40 x 5/16	2
8	82815-0405	SCREW, Bind Hd, 6-32 x 3/8	4
9	41152-0005	CONNECTOR, BNC	2
10	99090-0001	PAD, Spacer	4

1.6 OPTIONAL ACCESSORIES

- A. Altitude Reporter - AR-850, order number 03753-0306.

1.7 MISCELLANEOUS ITEMS REQUIRED BUT NOT SUPPLIED

Refer to Installation Section for additional details.

- A. Sufficient length of #22 and #16 AWG hookup wire.
- B. Molex Hand Crimper, HT-1921, Narco Part Number 41314-0001.
- C. Molex Pin Ejector, HT-1884, Narco Part Number 41314-0002.

1.8 OPERATOR LICENSE REQUIREMENTS

The Telecommunications Act of 1996, effective February 8, 1996 allowed the FCC the ability to eliminate the need for Aircraft Radio Station Licenses for domestic operation. The AT165 installation must comply with current FCC transmitter licensing requirements. To find out current details contact the FCC at 800-322-1117 or check the web at www.fcc.gov. The AT165 owner is responsible for obtaining proper licensing (if needed) before using the transponder.

1.9 OPERATION



FIGURE 1-1 AT 165 FRONT PANEL

1.9.1 FUNCTION SELECTOR SWITCH

The function selector is a four position rotary switch. The four positions are:

- OFF-** Turns off all power to the transponder.
- SBY-** Turns the transponder power supply on. When in **SBY**, the transponder will not reply to any interrogation. **SBY** is used at the request of the air traffic controller to selectivity clear his scope of traffic. When in this mode SBY will be shown on the Code display window.
- ON-** Places the transponder in Mode A, the aircraft identification mode. In addition to the aircraft's identification code, the transponder will also reply to altitude interrogations (Mode C) with discrete signals that do not contain altitude information. When in this mode ON will be shown on the Code display window.
- ALT-** The **ALT** position activates all the necessary circuitry (transponder to optional altitude digitizer and return) to respond to ATC (Air Traffic Control) altitude interrogations and aircraft identification interrogations with standard pressure altitude (29.92 inches Hg). The **ALT** position may be used in aircraft that are not equipped with the optional altitude digitizer, however, the only response will be discrete signals that do not contain altitude information. When in this mode ALT will be shown on the Code display window.

1.9.2 CODE SELECTOR/DATA ENTRY SWITCH

Pressing the Code Selector/Data Entry Switch once enables Transponder Code entry. The left most code digit will begin flashing. Turning the switch selects the code and pushing the switch again moves to the next digit from left to right. Once code selection has started, all four digits must be set before the code entry is completed. A total of 5 pushes completes the code entry process. If the switch is inadvertently pressed, it will stop the code entry process automatically in 10 seconds. The VFR code can subsequently be recalled automatically by pressing the VFR button. Code entry can not be started if the AT165 is in setup, Count Down Timer set, or Altitude Buffer set modes.

1.9.3 IDENT

Pressing the **IDENT** button will activate the SPIP (Special Position Identification Pulse) signal for approximately 20 seconds. This signal will "paint" an instantly identifiable image on the controller's scope. This signal must only be used upon request of a "Squawk IDENT" from the controller. Use at any other time could interfere with another aircraft sending a SPIP. The IDENT legend will appear in the Code window while the Ident signal is being sent.

1.9.4 VFR

Pressing the **VFR** button will cause the squawk code to either change from the user entered code to a VFR code or change back to the user entered code from the currently displayed VFR code. The last used squawk code is automatically recalled when the unit is cycled off and on.

1.9.5 HOLD

Pressing the **HOLD** button will enter the *Altitude Hold* mode and lock the current altitude as the HOLD altitude. The Altitude display area will now show the altitude difference relative to the HOLD altitude in 100ft increments. The altitude display area will flash if the *Altitude Buffer* value is exceeded. Additionally if the audio alert function has been installed, a warning will be heard. The audio warning will be present only while the unit is in the *Altitude Hold* mode. This is a warning only and is not tied to any navigation systems.

Depressing the **HOLD** button for two seconds or longer will allow the setting of the *Altitude Buffer*. The available range is 200ft to 2500ft. Once set, momentarily pressing **HOLD** again will save this buffer value. The buffer value will be retained when the unit is powered off. This mode must be exited before other functions can be accessed. Once started this mode will be exited when it has been inactive for 10 seconds. HOLD again will save this buffer value. The buffer value will be saved when the unit is powered off.

1.9.6 FUNC

Pressing the **FUNC** button cycles the timer display between *Flight Timer*, *Count Up Timer*, and *Count Down Timer*.

Holding the **FUNC** button in for 5 seconds or longer will Flip/Flop the left and right display areas. This function is extremely useful in the unlikely event of an unreadable LCD display. When the unit is turned off it will always restart with the displays in their default locations.

1.9.7 START/STOP

Pressing the **START/STOP** button will independently start or stop the *Count Up* and *Count Down* timers depending on which is currently displayed.

1.9.8 CRSR/CLR

When in *Flight Timer*, depressing the **CRSR/CLR** button for two seconds will reset the *Flight Timer*.
When in *Count Up Timer*, depressing the **CRSR/CLR** button for two seconds will reset the *Count Up Timer*.

When in *Count Down Timer*, with the timer stopped, momentarily pressing the **CRSR/CLR** button once will recall the preset count down time. Momentarily pressing this button again will activate the cursor in the timer window. At this point, changes to the *Count Down Timer* value can be made by using the Code Selector/Data Entry knob.

This page intentionally left blank.

2.1 INTRODUCTION

This section provides the necessary information for the installation of the AT165 TSO and, where required, optional accessories.

2.2 PRELIMINARY INSPECTION

2.2.1 Unpacking

Carefully unpack the Unit and inspect it for any damage that may have occurred during shipment. Refer to Section 1.5, Units and Accessories Supplied, and inventory the contents of the Installation Kit. Refer to Section 1.7, Miscellaneous Items Required but NOT Supplied for a listing of items and equipment needed for proper installation.

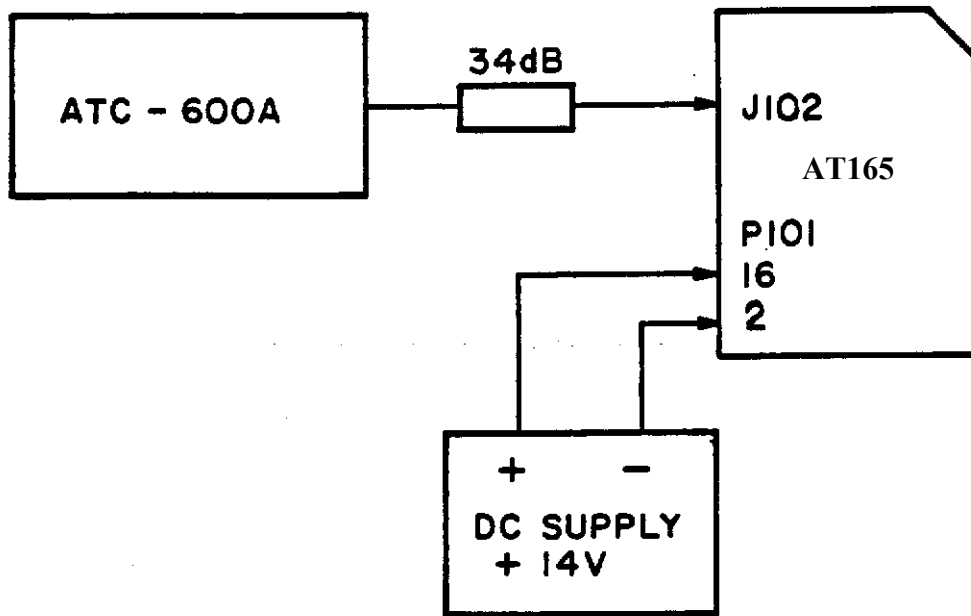

FIGURE 2-1. BENCH TEST SET-UP

2.2.2 Electrical Bench Test

2.2.2.1 Test Equipment Required

- A. Transponder and DME Test Set: IFR Model ATC-600A or equivalent.
- B. 34 dB attenuation pad.

2.2.2.2 Test Procedure

A. Set-Up

- 1. The AT165 should be tested while contained in the mounting tray with the RF cable installed.
- 2. When the AT165 is being interrogated by the ATC-600A, the RCV legend will be ON.

B. Receiver Sensitivity

- 1. Place the AT165 in the ON mode. Place the ATC-600A in the A/C CODE mode.
- 2. Rotate the ATC-600A XPDR SIG. level control full counterclockwise. The % scale of the XPDRRPLY meter should read 100%.
- 3. Rotate the XPDR SIG level control clockwise until the XPDR RPLY meter reads 90%.
- 4. The XPDR SIG level control indicator should be between -69 and -74 dBm. This is the MTL of the transponder.

2.2.2.2 Continued

5. Repeat steps 2, 3, and 4 with the AT165 in the ALT mode and the ATC-600A in the A/C ALT mode. The difference between the MTL readings should not be greater than 1 dBm.

C. SLS Side-Lobe Suppression

1. Place the AT165 in the ON mode. Place the ATC-600A in the A/C CODE mode.
2. Rotate the XPDR SIG. level control full counterclockwise. The XPDR RPLY meter should read 100%.
3. Set the XPDR SIG. level control to 3 dB above MTL level established in step B-4.
4. Set the SLS switch to 0 dB. The XPDR RPLY meter should read zero.
5. Set the SLS switch to 9 dB. The XPDR RPLY meter should read 90% minimum.

D. Code Selection

1. Place the AT165 in the ON mode. Place the ATC-600A to the A/C CODE mode.
2. The ATC-600A numerical display should display the code selected by the AT165. Several different codes should be selected.
3. Consider the AT165 Code Display Digits to be labeled A, B, C, and D (left to right). Digit A should light the ATC-600A Binary Readout lamp A_1 when it is in the 1 position, the A_2 lamp in the 2 position, and the A_1 and A_2 lamps in the 3 position. In each digit position, the sum of the subscripts of the Binary Readout lamps that light should equal the number selected.
4. Repeat the above procedure for digits B, C, and D.

E. Transmitter Frequency

1. Place the AT165 in the ON mode and set the Code to 0000.
2. Place the ATC-600A in the A/C CODE mode and set the POWER/FREQ switch to FREQ.
3. Adjust the GAIN control for a mid-scale reading on the POWER meter.
4. Rotate the XMTR FREQ control for a peak Indication on the POWER meter.
5. At peak, read the deviation from 1090 MHz directly from the XMTR FREQ control dial. The deviation should be no greater than ± 3 MHz.

F. Transmitter Power

1. Place the AT165 in the ON mode and set the Code to 6050.
2. Place the ATC-600A in the A/C CODE mode and set the POWER/FREQ switch to POWER.
3. Read 190 watts (minimum) on the POWER meter.

G. Ident

1. Place the AT165 in the ON mode. Place the ATC-600A in the A/C CODE mode.
2. Momentarily depress the IDENT button on the AT165.
3. The AT165 IDENT legend and the ATC-600A IDENT lamp should be active for approximately 20 ± 5 seconds.

2.2.2.2 Continued

H. Altitude Digitizer Inputs

The following procedure is a functional check of the Altitude Digitizer Inputs P101-6 through P101-14 only. Therefore, the numerical readout and INVALID ALT lamp on the ATC-600A should be ignored.

1. Place the AT165 in the ALT mode. Place the ATC-600A in the A/C ALT mode.
2. Placing an Altitude Digitizer Input at ground potential will activate a corresponding Binary Readout lamp on the ATC-600A. Table 2.1 lists the P101 pin numbers and their corresponding ATC-600A Binary Readout lamps.

TABLE 2.1 ALTITUDE DIGITIZER INPUTS

GROUND P101	ACTIVATE ATC-600A BINARY READOUT LAMP
6	A ₂
7	A ₁
8	A ₄
9	B ₄
10	B ₂
11	C ₂
12	B ₁
13	C ₄
14	C ₁

I. Back Lighting

With voltage applied on the Avionics Buss, applying a voltage to the Dimmer Buss will cause the AT165 backlighting to illuminate. The intensity of the backlighting is controlled by the front panel photocell.

Disconnect the transponder from the Test Set-Up.

2.3 MECHANICAL INSTALLATION

2.3.1 Mounting Tray

The AT165 is supplied with a mounting tray which is designed to mount behind the aircraft instrument panel using four number 6 screws. Figure 2-2 provides a detailed drawing of the tray and the parts of the Installation Kit. This figure also provides all the necessary dimensions for the panel cutout as well as dimensions for mounting brackets locations.

Mounting brackets (4) are not supplied due to the wide range in mounting requirements. Suitable mounting brackets may be fabricated from ordinary sheet metal or angle stock.

To ensure a sturdy mount, rear support for the unit should be provided.

2.3.2 Insertion And Removal Of The AT165

The AT165 is secured to the mounting tray by a hex head ramping screw running from the front panel to the rear of the unit and a self-locking nut attached to the tray rear panel. The access hole for the ramping screw is located on the front panel between the IDENT and VFR buttons (see Figure 1-1).

Slide the unit straight into the tray until the ramping screw contacts the self-locking nut. Using a 5/64" hex wrench, turn the screw clockwise until the mating connector is engaged and the unit is firmly secured in the tray.

CAUTION

DO NOT RAM THE UNIT INTO THE TRAY OR OVER TIGHTEN THE RAMPING SCREW.

To remove the unit, turn the ramping screw counterclockwise until it is clear of the self-locking nut and then pull the unit straight out.

Refer to table 1.2 for installation kit.

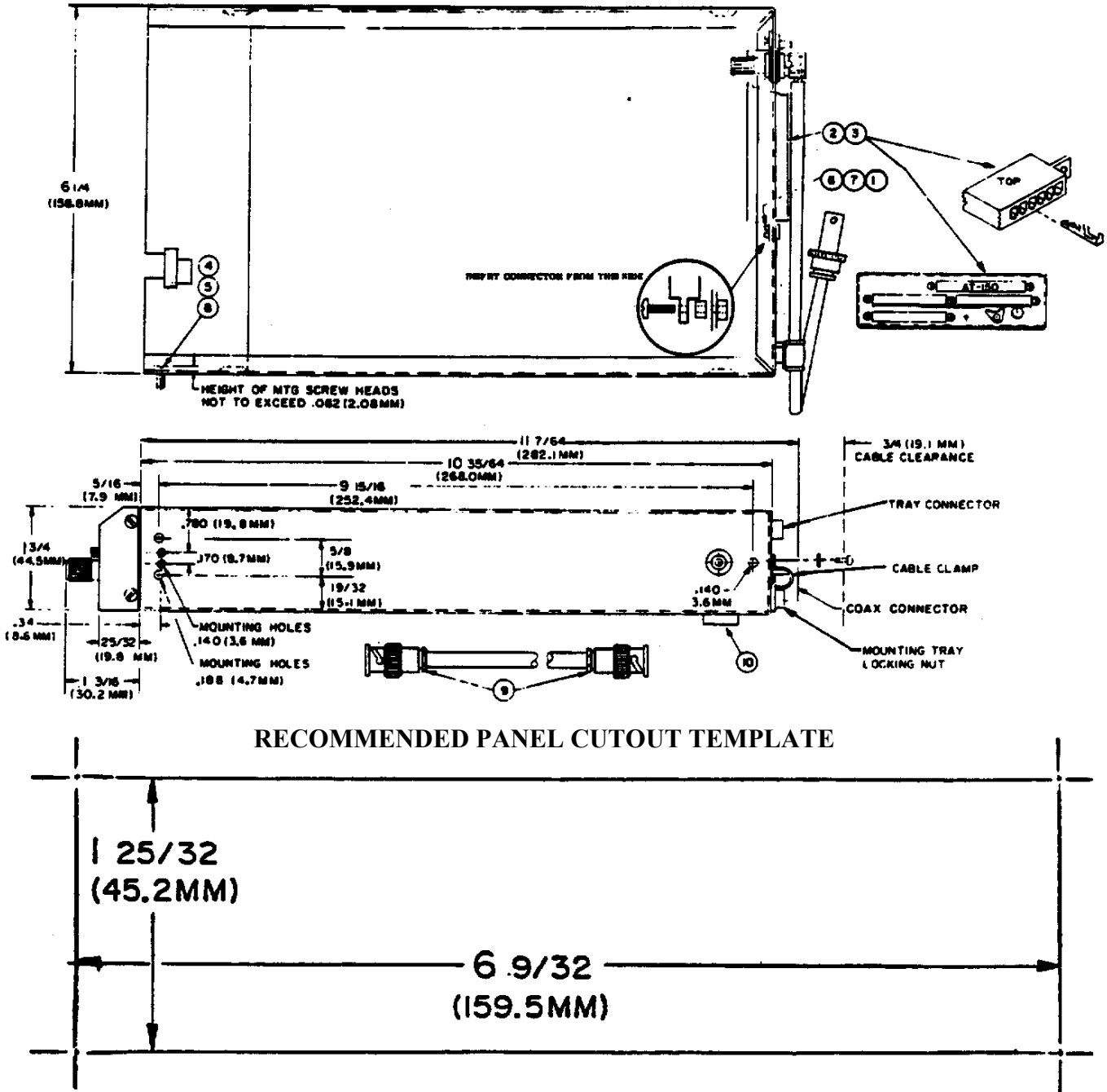

2.4 ANTENNA INSTALLATION

2.4.1 Antenna Location And Mounting

The AT165 Antenna supplied in the Installation Kit should be mounted on the bottom surface of the aircraft and located such that it will be in a vertical position when the aircraft is in level flight. The area surrounding the antenna location should be free of protrusions which could interfere with the line-of-sight characteristics of a UHF signal. The following rules should be observed with regard to the ground plane.

A. Metallic Mounting Surface

Mount the antenna in the center of a 6" (152.4 mm), minimum radius, ground plane. Antenna located near the edge of a ground plane may cause holes in the radiation and reception patterns.

B. Non-Metallic Mounting Surface

Aircraft with fabric, wood, or fiberglass fuselage covering must have a metal ground plane with a 6" (152.4 mm) minimum radius. This could be as simple as aluminum foil cemented inside wood or stiff fiberglass skin, or a doubler plate on a fabric covered aircraft. Such a ground plane should be either well bonded to the airframe, or well insulated from it, to prevent noise problems or erratic operation. Antenna mounting hardware must electrically connect the ground plane to the antenna.

A doubler plate will be needed for an airworthy Installation on most aircraft. Check the airworthiness regulations of the country of aircraft registry for acceptable mounting methods.

Figure 2-3 illustrates the antenna mounted and the necessary minimum clearances. Remove all oxidation, paint, or other finish to permit good electrical contact between the antenna base and the aircraft. Electrical ground will be carried by the mounting hardware.

DO NOT PAINT. The antenna should not be painted or coated with any other finish.

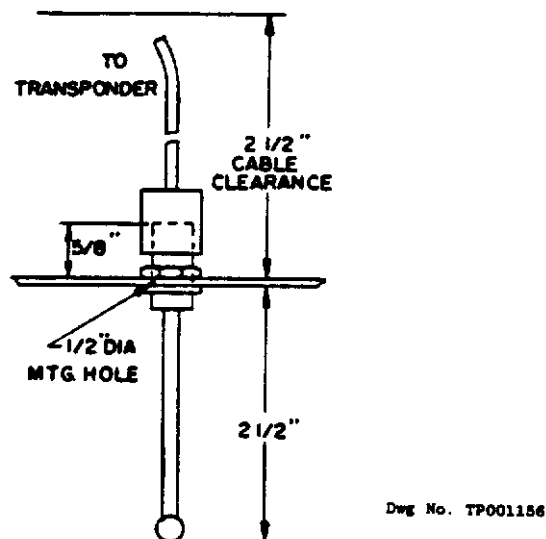

FIGURE 2-3. AT 150 ANTENNA MOUNTING

2.4.2 Antenna Extension Cable

The Installation Kit provides two UG-88U BNC connectors for fabrication of the antenna extension cable. The total length of this cable should not exceed 9 feet (2.7m). Should a cable of greater length be required, a coaxial cable type should be selected whose attenuation does not exceed 2 dB over the entire length.

2.5 ELECTRICAL INSTALLATION

2.5.1 Power And Interconnect Cable

The Installation Kit provides an 18 pin Molex connector along with sufficient pins for fabrication of the power and interconnect cable. Figure 2-4 presents the electrical connections and Figure 2-5 presents a system orientation diagram.

All signal leads should be 22AWG. A+ and ground leads should be 16 AWG. The ground lead should be connected directly to airframe ground.

A 3.0 amp circuit breaker should be provided between the unit and the aircraft power bus.

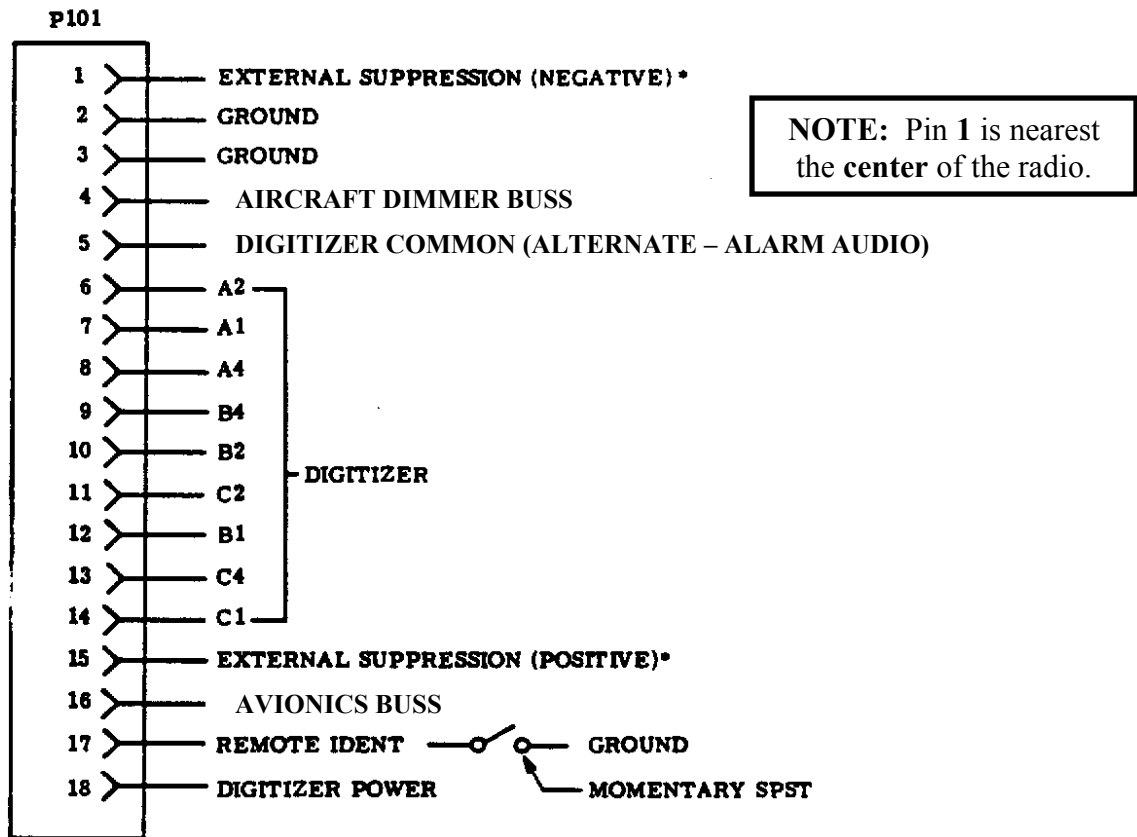

*TRANSMISSION MAY BE SUPPRESSED BY EITHER:
 a) GROUNDING PIN 1 OR b) APPLYING A POSITIVE VOLTAGE TO PIN 15

Dwg No. TP001138A

FIGURE 2-4 POWER AND INTERCONNECT CABLE

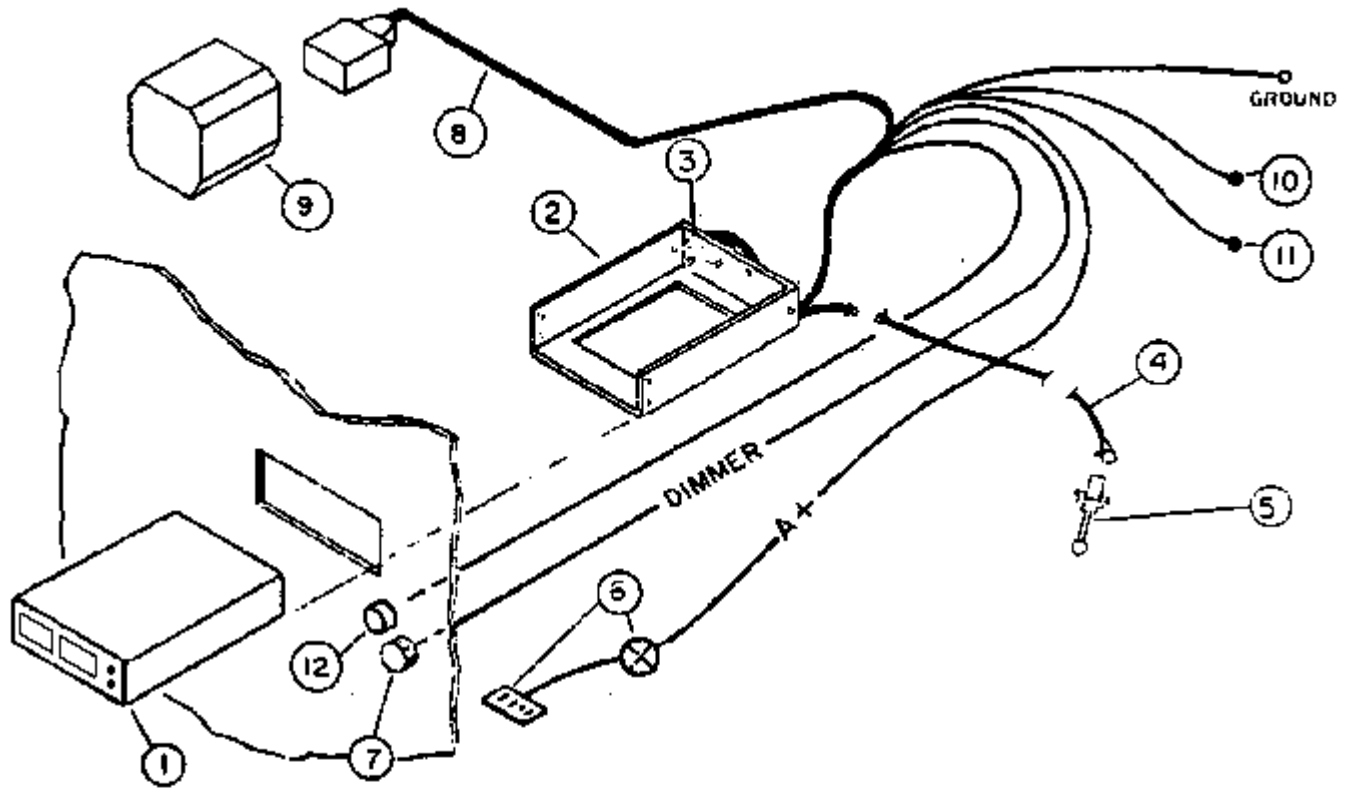

- | | |
|--|------------------------------|
| 1. Transponder | 7. Panel Lamp Dimmer |
| 2. Mounting Tray with Antenna Cable Assembly | 8. Altitude Digitizer Cable |
| 3. Power Connector | 9. Altitude Digitizer |
| 4. Antenna Cable Extension | 10. External Suppression (+) |
| 5. Antenna | 11. External Suppression (-) |
| 6. Power Supply Bus and Circuit Breaker | 12. Remote IDENT |

FIGURE 2-5. ORIENTATION DIAGRAM

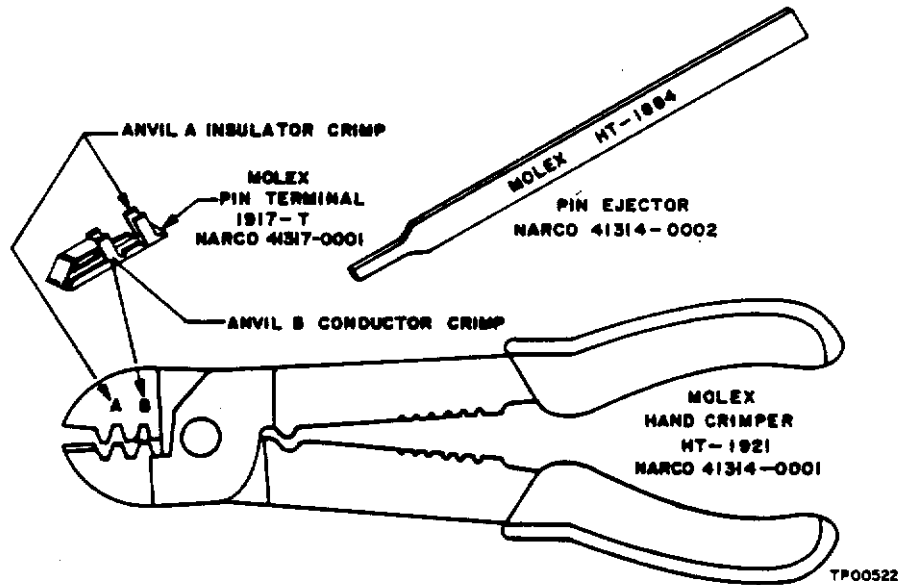

FIGURE 2-6. CRIMPING TOOL

2.5.2 Cable Fabrication

1. Strip wire 5/32" for PIN Terminal No. 1917-T.
2. Open tool (Engraved side toward you), from the opposite side, place the conductor tab section of the pin on Anvil B, Close tool slightly until the tabs touch the female jaw).
3. Insert stripped conductor until insulation is level with outside of jaw. Crimp by squeezing handles together until jaws are fully closed or sufficient crimp is made.
4. Move lead and pin to Anvil A. Crimp again until jaws are closed or sufficient crimp is made.
5. If necessary, straighten pin while still being held in the jaw.
6. Insertion
 - a. The PIN terminal may now be inserted into the desired pin location in the translucent connector housing. The pin cannot be inserted upside down. Right-side-up it slides in effortlessly. Be sure to push it all the way in, until a "click" can be felt, heard, or even seen by turning the translucent housing over.
 - b. There is no necessity to pull back on the lead itself except to test for the "locking feature", and then only with a moderate pull.

2.5.2 Continued

7. Extraction

- a. If a pin is erroneously inserted into the wrong housing position, or if at some later time a circuit change is desired, the pin can be removed easily. Slip the flat narrow blade portion of the tool into the mating side of the housing, under the pin. By holding the housing upside down one can see the blade slide in, up to the stop. This action picks up the locking key and allows the lead and pin to slip out of its position using a light pulling action on the lead. Neither pin nor position has been damaged allowing re-insertion in the same or another position.

8. Crimping with Pliers

The lead PIN Terminal connection using the Molex hand crimper provides a superior connection than with pliers. However, with care, a satisfactory connection can be made without the crimper.

- a. Strip wire 5/32" for PIN Terminal 1917-T.
- b. Using needle nose pliers, fold over conductor tabs firmly onto the conductor, one side then the other.
- c. Repeat step 2 for the Insulator tabs.

2.5.3 Backlighting

Pilot lamp 14/28V OPERATION

The AT165 backlighting is activated when a voltage is present on the Aircraft Dimmer Buss and the Avionics Buss is active (If there is no Dimmer Buss the dimmer pin can be connected to the Avionics Buss).

2.5.4 External Suppression

The AT165 transponder may be externally suppressed by other avionics equipment whose transmissions may be interfered with by simultaneous AT165 transmissions. P101-15 may be connected to equipment that supply positive suppression pulses. P101-1 may be connected to equipment that supply negative suppression pulses.

In aircraft equipped with dual transponders, P101-1 of both transponders may be connected to a remote SPDT switch which will alternately suppress the transponders by placing the appropriate P101-1 at ground potential. This switch may be located at any convenient place in the cockpit and labeled appropriately.

2.5.5 Remote IDENT

P101-17 provides for the connection of remote IDENT switch. This switch should be a momentary SPST type and connected such that activation places P101-17 at ground potential. This switch may be located at any convenient place in the cockpit and labeled appropriately.

2.5.6 Altitude Digitizer

P101 pins 5 through 14 provide for the connection of an altitude digitizer. The altitude digitizer, sensing atmospheric pressure, converts pressure/altitude information into digitized altitude data. This data is then transmitted to the control center by the transponder. Narco recommends the Model AR 850 for this application.

2.5.7 Warning Audio Alert

The AT165 has an optional audio alert for the Count Down Timer and Altitude Hold functions. To use this audio the switch accessed on the right hand side rail must be in the Alarm Audio position. Additionally the AT165 installation wiring must be configured to send the audio to the headphones and/or the speaker.

2.6 POST INSTALLATION TESTS

To certify the installation, FAA Form 337 must be completed. In addition, weight and balance or any operating limitations must be entered into the aircraft logbook. Refer to the current Federal Aviation Regulations for any additional requirements.

Weight	1.7 lbs. (0.77 kg)		
Power Requirements		13.75 VDC	27.5VDC
	Standby	575mA	460mA
	Transmit	1.75 A	880mA
	OFF (Pilot Lamps)	260mA	260mA
	Dimmer Buss	14 μ A	28 μ A

2.6.1 Preflight Tests

A. A preflight test should be performed using an ATC-600A Transponder and DME test set or equivalent. The test set should be set-up as described in the ATC-600A Operators Manual and following tests should be conducted:

1. Pilot Code
2. Peak Transmitter Power
3. Transmitter Frequency
4. SLS Operation
5. IDENT
6. Percent Reply

B. In the event that an altitude digitizer has been installed, the altitude digitizer manual should be consulted for proper procedures and the following tests should be conducted:

1. Altitude Code
2. Invalid Altitude Code Output

2.6.2 SETUP

Starting with the AT165 turned off, hold in the FUNC button while turning the function switch to the SBY position. The AT165 will now be at the contrast adjust screen. Rotating the data entry switch CW or CCW will adjust the display's contrast. Once the desired contrast is achieved pressing the FUNC button will save this setting and continue to the Display mode screen.

The Display mode screen allows three choices for the display: AUTO, POS, and NEG

AUTO – Black letters on a light background switching to light letters on a black background as the ambient light is reduced.

POS- Black letters on a light background.

NEG – Light letters on a black background.

Pressing the FUNC button will save the Display mode setting and continue to the GRAY code input page.

The GRAY code input page shows the current altitude and the status of each of the GRAY code altitude inputs. A filled box indicates a ground on the altitude input. This screen is used as an aid in installation troubleshooting.

Pressing the FUNC button exits the setup procedure.

2.6.3 Flight Test

After installation, a flight test should be performed to check overall operation and system compatibility.

A. Range Test

1. The AT165 should furnish a strong and stable return signal to an interrogating radar facility that is 50 NM away when the aircraft is flying at 6000 feet. At this altitude and distance, fly a flat circle while having a FAA station monitor the transponder return signal. There should be no more than two sweeps of the interrogating radar without a return response.

B. Surveillance Approach

1. Perform an approach to a runway of an airport starting at least 10 NM from the airport served by Airport Surveillance Radar (ASR) having an Air Traffic Control Radar Beacon System (ATCRBS) facility. Alternately, a simulated approach and letdown may be made along a path parallel to, but separated, three to four miles from a vertical plane through the location of the ASR facility. The approach should be made at the normal rate of decent and normal approach and landing configuration for the aircraft and should continue down to an altitude of 200 feet. Not more than one "drop out" should occur for any 10 radar sweeps during final approach.

C. Electromagnetic Compatibility

1. The transponder should not cause the performance of other systems aboard the aircraft to be degraded below their normal capability and transponder operation should not be adversely affected by other equipment.

2.7 AIRCRAFT LICENSE REQUIREMENTS

The AT165 installation must comply with current FCC transmitter licensing requirements. To find out specific details on whether a particular installation requires licensing contact the FCC at 800-322-1117.

If an aircraft license is required, make application for a license on FCC form 404, Application for Aircraft Radio Station License.

The aircraft owner accepts all responsibility for obtaining the proper licensing before using the AT165

This equipment has been type accepted by the FCC and entered in their list of type accepted equipment under the FCC identifier "A9SAT165".

This page intentionally left blank.

APPENDIX A

A.1 ENVIRONMENTAL QUALIFICATION FORM

NOTE : A COPY OF THIS FORM IS TO BE FILED WITH THE OWNER'S AVIONICS RECORDS.

NOMENCLATURE : TRANSPONDER
MODEL : AT165
MANUFACTURER : Narco Avionics Inc.
ADDRESS : 270 Commerce Drive
Fort Washington, PA 19034
USA

CONDITIONS	DO-160C SECTION, PARAGRAPH#	DESCRIPTION OF CONDUCTED TESTS
Temperature and Altitude	4.0	Equipment tested to category "A1C1"
Ground Survival Low Temperature	4.5.1	-55°C
Operating Low Temperature	4.5.1	-20°C
Ground Survival High Temperature	4.5.2	+85°C
Short-Time High Operating Temperature	4.5.2	+75°C
Operating High Temperature	4.5.3	+55°C
In Flight Loss of Cooling	4.5.4	Equipment tested to category "V", Greater than 30 Minutes
Altitude	4.6.1	35,000 feet (10,668 meters)
Decompression	4.6.2	8,000 feet to 35,000 feet Δ within 15 seconds, then maintained for 10 minute minimum duration.
Overpressure	4.6.3	-15,000 feet for 10 minutes
Temperature Variation	5.0	Equipment tested to category "C".
Humidity	6.0	Equipment tested to category "A".
Operational Shocks and Crash Safety	7.0	Equipment tested to operational and crash safety tests.
Operational	7.2	
Crash Safety	7.3	
Vibration	8.0	Equipment tested without shock mounts to Categories M, N and B (DO-160C Table 8-1)
Explosion	9.0	Equipment identified as Category "X", no test required.
Waterproofness	10.0	Equipment identified as Category "X", no test required.
Fluids Susceptibility	11.0	Equipment identified as Category "X", no test required.
Sand and Dust	12.0	Equipment identified as Category "X", no test required.
Fungus	13.0	Equipment identified as Category "X", no test required.
Salt Spray	14.0	Equipment identified as Category "X", no test required.
Magnetic Effect	15.0	Equipment tested to Category "Z"
Power Input	16.0	Equipment tested to Category "B"
Voltage Spike	17.0	Equipment tested to Category "B"
Audio Frequency Susceptibility	18.0	Equipment tested to Category "B"
Induced Signal Susceptibility	19.0	Equipment tested to Category "A"
Radio Frequency Susceptibility	20.0	Equipment tested to Category "T"
Radio Frequency Emission	21.0	Equipment tested to Category "B"
Lightning Induced Transient Susceptibility	22.0	Equipment identified as Category "X", no test required.
Lightning Direct Effects Test	23.0	Equipment identified as Category "X", no test required.
Icing	24.0	Equipment identified as Category "X", no test required.
Other Test		Fire resistance tests were conducted in accordance with Federal Aviation Regulations Part 15, Appendix F.

A.2 CONTINUED AIRWORTHINESS

Other than for regulatory periodic functional checks, the AT165 does not require periodic maintenance. If the AT165 exhibits non-conformal operation, the AT165 should be checked at a qualified service facility.

INSTALLATION
MANUAL REVISION HISTORY

MANUAL REVISION HISTORY

Page Number	Revision Level	Date
i	REV 1.0	MAR 04
ii	REV 1.0	MAR 04
1-1	REV 1.0	MAR 04
1-2	REV 1.0	MAR 04
1-3	REV 1.0	MAR 04
1-4	REV 1.0	MAR 04
1-5	REV 1.0	MAR 04
1-6	REV 1.0	MAR 04
1-7	REV 1.0	MAR 04
1-8	REV 1.0	MAR 04
1-9	REV 1.0	MAR 04
2-1	REV 1.0	MAR 04
2-2	REV 1.0	MAR 04
2-3	REV 1.0	MAR 04
2-4	REV 1.0	MAR 04
2-5	REV 1.0	MAR 04
2-6	REV 1.0	MAR 04
2-7	REV 1.0	MAR 04
A-1	REV 1.0	MAR 04
A-2	REV 1.0	MAR 04
R-1	REV 1.0	MAR 04