

**IO-520-B, BA, BB  
C, CB  
M & MB**

**CONTINENTAL<sup>®</sup> AIRCRAFT ENGINE**

**OPERATION  
AND  
INSTALLATION  
MANUAL**



**TECHNICAL CONTENT ACCEPTED BY THE FAA**

**Publication X30618**

©2011 CONTINENTAL MOTORS, INC.

**AUG 2011**



**Supersedure Notice**

This manual revision replaces the front cover and list of effective pages for Publication Part No. X30618, dated March 1994. Previous editions are obsolete upon release of this manual.

**Effective Changes for this Manual**

|         |                |  |  |
|---------|----------------|--|--|
| 0 ..... | March 1994     |  |  |
| 1 ..... | 31 August 2011 |  |  |
|         |                |  |  |
|         |                |  |  |

**List of Effective Pages**

Document Title: IO-520 Permold Series Engine Operation and Installation Manual  
 Publication Number: X30618 Initial Publication Date: March 1994

| Page                      | Change | Page                     | Change | Page | Change | Page | Change |
|---------------------------|--------|--------------------------|--------|------|--------|------|--------|
| Cover.....                | 1      | 72-00-01 thru 72-00-02.0 |        |      |        |      |        |
| A.....                    | 1      |                          |        |      |        |      |        |
| i thru vi.....            | 0      |                          |        |      |        |      |        |
| 1-00-01 thru 1-00-04 .... | 0      |                          |        |      |        |      |        |
| 2-00-01 thru 2-00-02 .... | 0      |                          |        |      |        |      |        |
| 4-00-01 thru 4-00-02 .... | 0      |                          |        |      |        |      |        |
| 5-00-01 thru 5-00-02 .... | 0      |                          |        |      |        |      |        |
| 6-00-01 thru 6-00-02 .... | 0      |                          |        |      |        |      |        |
| 6-10-01 thru 6-10-06 .... | 0      |                          |        |      |        |      |        |
| 6-20-01 thru 6-20-02 .... | 0      |                          |        |      |        |      |        |
| 12-00-01 thru 12-00-06    | 0      |                          |        |      |        |      |        |
| 14-00-01 thru 14-00-06    | 0      |                          |        |      |        |      |        |
| 15-00-01 thru 15-00-10    | 0      |                          |        |      |        |      |        |
| 15-05-01 thru 15-05-04    | 0      |                          |        |      |        |      |        |
| 15-10-01 thru 15-10-04    | 0      |                          |        |      |        |      |        |
| 15-15-01 thru 15-15-14    | 0      |                          |        |      |        |      |        |
| 70-00-01 thru 70-00-02    | 0      |                          |        |      |        |      |        |

Published and printed in the U.S.A. by Continental Motors, Inc.

Available exclusively from the publisher: P.O. Box 90, Mobile, AL 36601

Copyright © 2011 Continental Motors, Inc. All rights reserved. This material may not be reprinted, republished, broadcast, or otherwise altered without the publisher's written permission. This manual is provided without express, statutory, or implied warranties. The publisher will not be held liable for any damages caused by or alleged to be caused by use, misuse, abuse, or misinterpretation of the contents. Content is subject to change without notice. Other products and companies mentioned herein may be trademarks of the respective owners.

**OPERATOR AND INSTALLATION MANUAL**  
**FOR**  
**IO-520 AIRCRAFT ENGINE**  
**PERMOLD**

**-NOTICE-**

The operator must comply with all the instructions contained in this manual and related publication in order to assure safe and reliable engine performance. Failure to comply will be deemed misuse, thereby relieving the engine manufacturer of responsibility under its warranty.

This manual contains no warranties, either expressed or implied. The information and procedures contained herein provide the operator with technical information and instructions applicable to safe operation.

Refer to the Pilot's Operating Handbook published by the Airframe Manufacturer for operating instructions and specifications relating to your specific aircraft.

**-NOTICE-**

Teledyne Continental Motors (TCM) engine operating instructions are generated prior to and independently of the aircraft operating instructions established by the airframe manufacturer. TCM's operating instructions are developed using factory controlled parameters that are not necessarily the same as those specifications required to satisfy a specific aircraft / engine installation. Because of this difference the aircraft operator should use the airframe manufacturer's operating instructions found in the Pilots Operating Handbook (POH) while operating the aircraft unless otherwise specified by the original airframe manufacturer.

# WARNING

(Please note the following statements from FAA Advisory Circular 20-62C entitled "ELIGIBILITY, QUALITY, AND IDENTIFICATION OF APPROVED REPLACEMENT PARTS"):

3. **BACKGROUND.** An increasing amount of replacement parts (including standard parts), materials, appliances, and instruments are offered for sale as being of aircraft quality when actually the quality and origin of these units are unknown. Users of such units are usually not aware of the potential hazards involved with replacement parts that are **not** eligible for use on certificated aircraft. Frequently such units are deceptively advertised or presented as "**unused**," "**like new**," or "**remanufactured**." This implies that the quality of such units is equal to an original or appropriately repaired or overhauled unit.

The performance rules for replacement of parts and materials used in the maintenance and alteration of U.S. certificated aircraft are specified in Federal Aviation Regulations (FAR) 43.13 and FAR 145.57. The responsibility for the continued airworthiness of the aircraft, which includes the replacement of parts, is the **responsibility** of the owner/operator as outlined in FAR 91.163, FAR 121.363, FAR 123.45, FAR 127.131 and FAR 135.143 (a).

4. **IDENTIFICATION OF THE APPROVED PARTS.** Approved serviceable replacement parts are identified as follows:

- a. By an FAA Form 8130-3 (Formerly FAA Form 186), Airworthiness Approval Tag. An Airworthiness Approval Tag identifies a part or group of parts that have been approved by authorized FAA representatives.
- b. By an FAA Technical Standard Order (TSO) number and identification mark that indicates the part or appliance has been manufactured under the requirements of FAR 37.
- c. By an FAA/PMA symbol, together with the manufacturer's name, trademark or symbol, part number, and the make and model of the type certificated product on which the part is eligible for installation, stamped on the part. An FAA Parts Manufacturer Approval (FAA/PMA) is issued under FAR 21.305. The make and model information may be on a tag attached to the part.
- d. By shipping ticket, invoice, or other document which provides evidence that the part was produced by a manufacturer holding an FAA Approved Production Inspection System issued under FAR 21, Subpart F, or by a manufacturer holding an FAA Production Certificate issued under FAR 21, Subpart G.
- e. By a certificate of airworthiness for export issued by a foreign government under the provisions of FAR 21, Subpart N.

11. **KNOW YOUR SUPPLIER.** It has come to our attention that many reproduced parts and components, particularly instruments which have been manufactured by persons other than the original manufacturer, are available for purchase and installation on U.S. certificated aircraft. Often, an original part is used as a sample to produce duplicates. The reproduced parts appear to be as good as the original part. However, there are many unknown factors to be considered that may not be readily apparent to the purchaser, i.e., heat treating, plating, inspections, tests and calibrations. All too often the faulty part is not discovered until a malfunction or an accident occurs.

12. **SUMMARY.** Aircraft record entries approving the airframe/powerplant for return to service after maintenance or overhaul must be accomplished in accordance with part 43 of the Federal Aviation Regulations (latest revision). The owner/operator, as denoted in paragraph 3 of this advisory circular, is responsible for the continued airworthiness of the aircraft. To assure continued safety in aircraft operation, it is essential that great care be used when inspecting, testing, and determining the acceptability of all parts and materials. Particular caution should be exercised when the identity of materials, parts, and appliances cannot be established or when their origin is in doubt.

# CHAPTER INDEX

| Chapter |  | Page     |
|---------|--|----------|
| 1       | Introduction . . . . .   | 1-00-01  |
| 2       | Tools and Equipment . . . . .  | 2-00-01  |
| 3       | Approved Products . . . . .  | 2-00-01  |
| 4       | Airworthiness Limitations . . . . .                                  | 4-00-01  |
| 5       | Time Limits/Operational Inspections/Engine Troubleshooting . . . . . | 5-00-01  |
| 6       | Unpacking, Deinhibiting, Installation, Testing & Removal . . . . .   | 6-00-01  |
| 12      | Servicing Fluids . . . . .   | 12-00-01 |
| 14      | Engine Preservation and Storage . . . . .                            | 14-00-01 |
| 15      | Operating Procedures . . . . .                                       | 15-00-01 |
| 70      | Standard Practices . . . . .   | 70-00-01 |
| 72      | Engine-Reciprocating . . . . .                                       | 72-00-01 |

INTENTIONALLY

LEFT

BLANK

# FIGURE INDEX

| Figure No. |  | Page     |
|------------|--|----------|
| 6-00-01    | Installation Drawing IO-520-B, BA, BB . . . . .              | 6-00-04  |
| 6-00-02    | Installation Drawing IO-520-C, CB . . . . .                  | 6-00-05  |
| 6-00-03    | Installation Drawing IO-520-M, MB . . . . .                  | 6-00-06  |
| 12-00-01   | General IO-520 Permold Series Oil Servicing Points . . . . . | 12-00-02 |
| 15-15-01   | Fuel Flow vs. BHP for IO-520-B,BA & BB . . . . .             | 15-15-05 |
| 15-15-02   | Sea Level Performance Curves for IO-520-B,BA & BB . . . . .  | 15-15-06 |
| 15-15-03   | Altitude Performance Curves for IO-520-B,BA & BB . . . . .   | 15-15-07 |
| 15-15-04   | Fuel Flow vs. BHP for IO-520-C & CB . . . . .                | 15-15-08 |
| 15-15-05   | Sea Level Performance Curves for IO-520-C & CB . . . . .     | 15-15-09 |
| 15-15-06   | Altitude Performance Curves for IO-520-C & CB . . . . .      | 15-15-10 |
| 15-15-07   | Fuel Flow vs. BHP for IO-520M & MB . . . . .                 | 15-15-11 |
| 15-15-08   | Sea Level performance Curves for IO-520M & MB . . . . .      | 15-15-12 |
| 15-15-09   | Altitude Performance Curves for IO-520M & MB . . . . .       | 15-15-13 |

INTENTIONALLY

LEFT

BLANK



# CHAPTER 1

## INTRODUCTION

### Section Index

| <b>Section</b> |                                | <b>Page</b> |
|----------------|--------------------------------|-------------|
| 1-00-00        | Introduction . . . . .         | 1-00-02     |
| 1-00-01        | Scope . . . . .                | 1-00-02     |
| 1-00-02        | Related Publications . . . . . | 1-00-03     |

## 1-00-00 INTRODUCTION

The Operator's and Installation Manual contains the information necessary to operate and assist installation of an aircraft engine.

The Operator's and Installation Manual is prepared in accordance with the General Aviation Manufacturer's Association (GAMA) format. The GAMA format utilized a set chapter numbering system. Airframe related chapters will not appear in powerplant manuals. Only chapters that are applicable to a manual's purpose will appear in that manual.

A description of the format numbering system is located in the "Related Publications" section of this manual.

For a list of chapters contained in this manual refer to the Table of Contents.

In producing this publication, considerable effort has been put forth to provide grammatically clear and accurate information. Teledyne Continental Motors solicits the user's assistance in providing information relating to changes that the user may suggest. This information should be forwarded to:

Teledyne Continental Motors  
Aircraft Products  
P.O. Box 90  
Mobile, Alabama 36601  
Attn: Publications Department

## 1-00-01 SCOPE

Requirements, cautions and warnings regarding operation of this engine are not intended to impose undue restrictions, but are intended to enable the pilot to obtain maximum performance from the engine in accordance with safety and efficiency. Abuse, misuse, or neglect of any piece of equipment can cause eventual engine malfunction and stoppage. Failure to observe the instructions contained in this manual constitutes unauthorized operation in areas unexplored during development or in areas which experience has proved to be undesirable or detrimental.

Notes, Cautions and Warnings are included throughout this manual. Application is as follows:

NOTE. . .Special interest information which may facilitate the operation of equipment.

*CAUTION. . .Information issued to emphasize certain instructions or to prevent possible damage to engine, accessories, and personnel.*

**WARNING. . .Information which, if disregarded, may result in severe damage to or destruction of the engine or endangerment to personnel.**

## 1-00-02 RELATED PUBLICATIONS

The Operator's and Installation, Parts, Maintenance and Overhaul manuals all contain the GAMA standardized format numbering system. Subject matter is cross referenced between the manuals by chapter and section numbers.

Example:

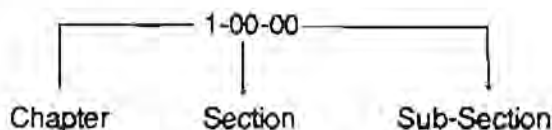

The following is a listing of relating engine and accessory publications.

1. Overhaul Manual, Form X30626A.
2. Maintenance Manual, Form X30625A.
3. Parts Catalog, Form X30624A.
4. Operator's and Installation Manual, Form X30618.
5. TCM Service Bulletins, Complete Set.
6. Fuel Injection Manual, Form X30593A.
7. Starter Service Instruction Form X30592.
8. TCM Ignition Systems Master Service Manual, Form X40000.
9. Alternator Service Instructions. Form X30531-3.

The above publications can be ordered through your Teledyne Continental Motors Distributor or ordered directly, if prepaid, from:

Teledyne Continental Motors  
Aircraft Products  
P. O. Box 90  
Mobile, AL 36601

For price information see TCM Optional and Current Publications Service Bulletins, M92-2 and M92-3, or current revision as applicable.

10. Slick Ignition Systems Master Service Manual, Form F-1100. This manual can be ordered from:

Slick Aircraft Products  
Unison Industries  
530 Blackhawk Park Avenue  
Rockford, Illinois 61104  
Tel (815) 965-4700  
Attn: Subscription Department

INTENTIONALLY

LEFT

BLANK

## **CHAPTER 2**

### **TOOLS AND EQUIPMENT**

Refer to IO-520 Permold Series Maintenance Manual Form X30625A or Overhaul Manual Form X30626A Chapter 2 as applicable.

## **CHAPTER 3**

### **APPROVED PRODUCTS**

Approved lubricants, sealants, paints, silk thread and lockwire are located in Chapter 3 of the IO-520 Maintenance Manual, Form X30625A, and Overhaul Manual, Form X30626A.

See section 1-00-02 Related Publications for ordering information on any of the above listed manuals.

INTENTIONALLY

LEFT

BLANK

## CHAPTER 4

### AIRWORTHINESS LIMITATION

The Airworthiness Limitations Section is F.A.A. Approved and specifies maintenance required by the Federal Aviation Regulations unless an alternative program has been F.A.A. Approved. This section is part of the type design of the IO520 engine pursuant to certification requirements of the Federal Aviation Regulations.

1. Mandatory Replacement Times.

Subject to additional information contained in F.A.A. Approved Service Bulletins issued after the date of certification, the IO-520 engine does not contain any components having mandatory replacement times required for type certification.

2. Mandatory Inspection Intervals.

Subject to additional information contained in F.A.A. Approved Service Bulletins issued after the date of certification, 50 hours and 100 hour inspections as described in the IO-520 Maintenance and Operator's Manual and inspections mandated by the Federal Aviation Regulations are required for type certification.

3. Other Related Procedures.

Subject to additional information contained in F.A.A. Approved Service Bulletins and Related Publications in Section 1-00-02 issued after the date of certification, the IO-520 engine does not have any inspection-related or replacement time-related procedures required for type certification.

4. Distribution of Changes to Airworthiness Limitations.

Changes to Airworthiness Limitations section constitute changes to the type design of the IO-520 engine and require F.A.A. approval pursuant to Federal Aviation Regulations. Such changes will be published in F.A.A. Approved Service Bulletins, which are furnished to subscribers to TCM Service Bulletins and can be obtained by writing TCM, P.O. Box 90, Mobile, Alabama 36601.

INTENTIONALLY

LEFT

BLANK



**CHAPTER 5**  
**TIME LIMITS/OPERATIONAL INSPECTIONS/ENGINE**  
**TROUBLESHOOTING**

Refer to the IO-520 Permold Series Maintenance manual Form X30625A Chapter 5.  
See section 1-00-02 related publications for ordering information.

INTENTIONALLY

LEFT

BLANK

## CHAPTER 6

# UNPACKING, DEINHIBITING, INSTALLATION AND TESTING

### Section Index

| Section |  | Page    |
|---------|--|---------|
| 6-00-00 | General . . . . .                          | 6-00-02 |
| 6-00-01 | Unpacking . . . . .                        | 6-00-02 |
| 6-00-02 | Ground Handling . . . . .                  | 6-00-02 |
| 6-00-03 | Crating and Shipping . . . . .             | 6-00-02 |
| 6-10-01 | Preparation for Service . . . . .          | 6-10-01 |
| 6-10-02 | Engine Installation Instructions . . . . . | 6-10-02 |
| 6-20-01 | Preflight and Run-Up . . . . .             | 6-20-01 |
| 6-20-02 | Flight Testing . . . . .                   | 6-20-01 |

## 6-00-00 GENERAL

Technicians involved with engine preparation and installation into the airframe must possess a detailed knowledge of safe procedures used in engine servicing and the operation of ground support equipment.

The engine must have a detailed visual inspection prior to installation in the airframe.

## 6-00-01 UNPACKING

Packaging Category "A" (Cardboard Container)

1. Cut steel banding straps securing the container.

*CAUTION...Straps may spring loose when cut.*

2. Remove the staples from the base of the cardboard cover.
3. Lift cardboard cover vertically and remove.
4. Attach a hoist to the engine lifting eye, located at the top of the crankcase backbone. Take up slack on the hoist, then cut the steel banding straps holding the engine to the base. Lift the engine vertically and install on a transportation stand or dolly.

*CAUTION...Straps may spring loose when cut.*

Packaging Category "B" (Wooden or Plastic Container)

1. Remove the attaching hardware from the base.
2. Lift the wooden cover vertically and remove.
3. Open the moisture proof plastic bag.
4. Attach a hoist to the engine lifting eye located at the top of the crankcase backbone. Take up slack on the hoist, prior to loosening the engine mount bolts; then remove the bolts from the shipping shock mounts. Lift the engine vertically and install on a transportation stand or dolly.

## 6-00-02 GROUND HANDLING

After engine is removed from container (attached to hoist) proceed with care. Do not let engine front, rear, sides or bottom come in contact with any obstructions as the extreme weight may cause damage to the engine or components. If contact has occurred, inspect for obvious or consequential damage.

## 6-00-03 CRATING AND SHIPPING

Category "A" (cardboard container). Lower engine onto container base and attach with metal banding straps. Install and attach container cover.

Category "B" (wooden container). Lower engine onto container base. Attach engine using shock mounts and bolts cover engine with plastic bag. Install and attach container cover to base.

## 6-10-01 PREPARATION FOR SERVICE

If the engine is **not** to be installed within five (5) days after removal of shipping plugs, it must be represerved in accordance with procedures listed in Chapter 14.

If the engine is to be installed within five (5) days after unpacking, remove the shipping plugs installed in the lower spark plug holes and turn the crankshaft through at least two complete revolutions in order to remove the cylinder preservation oil from the cylinder. Remove the shipping plugs installed in the upper spark plug holes and inspect the cylinder bores with a borescope for rust or contamination. Contact your Teledyne Continental Motors Distributor if any abnormal condition is noted.

Install the upper spark plugs finger tight and torque the lower spark plugs to 300-360 in. lbs. Do not lubricate spark plug threads prior to installation.

NOTE...Remove all protective plugs. Drain preservative from oil sump. Service the lubrication system with mineral (non-detergent) oil or Corrosion Preventive oil corresponding to MIL-C-6529 Type II. See Chapter 12 for sump capacity.

Remove the shipping plate from the propeller governor pad forward of number 6 cylinder. Lubricate the governor shaft splines with engine oil; install a new gasket and then install the propeller governor control. Attach with plain washers, new lock washer, and torque the nuts in accordance with aircraft's Manufacturer's recommendation.

*CAUTION...Align spline of governor drive gear and assure that the governor is fully seated to the crankcase prior to installing the attaching hardware. This will eliminate the possibility of misalignment forcing the drive gear over the camshaft gear, requiring engine disassembly.*

Optional Accessories: Optional accessories such as hydraulic pumps, vacuum pumps, etc., may be installed on the accessory drive pads located on the upper rear portion of the crankcase. Remove the accessory drive covers and install new gaskets. Install accessories in accordance with the airframe manufacturer's instructions.

**WARNING...Because oil pressure is applied to the face of the accessory drive pads, proper installation procedures and materials must be used to prevent oil loss.**

Install all airframe manufacturer required cooling baffles, hoses, fittings, brackets and ground straps in accordance with airframe manufacturers installation instructions.

**6-10-02 ENGINE INSTALLATION INSTRUCTIONS (See Figure 6-10-01 thru 6-10-03)**

Install in accordance with airframe manufacturer's instructions and the following generalized instructions. The engine must be hoisted using the lifting eye bracket.

1. Torque fasteners as required by the airframe manufacturer.
2. Safety wire bolts as required by airframe manufacturer's instructions.
3. Re-torque hardware that was loosened to facilitate installation.

*CAUTION...Remove all protective covers, plugs, caps and identification tags as each item is connected or installed.*

*NOTE...See airframe manufacturer's instructions for engine to airframe connections.*

**WARNING...The aircraft fuel tanks and lines must be purged to remove all contamination prior to installation of the main fuel inlet line to the fuel pump. Failure to comply can cause erratic fuel injection system operation and malfunction to its components.**

**WARNING...Do not install the ignition harness "B" nuts on the spark plugs until the propeller installation is completed and the ignition switch system has been determined to be functioning properly. Failure to comply will result in bodily injury when the propeller is rotated during installation.**

4. Install the approved propeller in accordance with the airframe manufacturer's instructions.

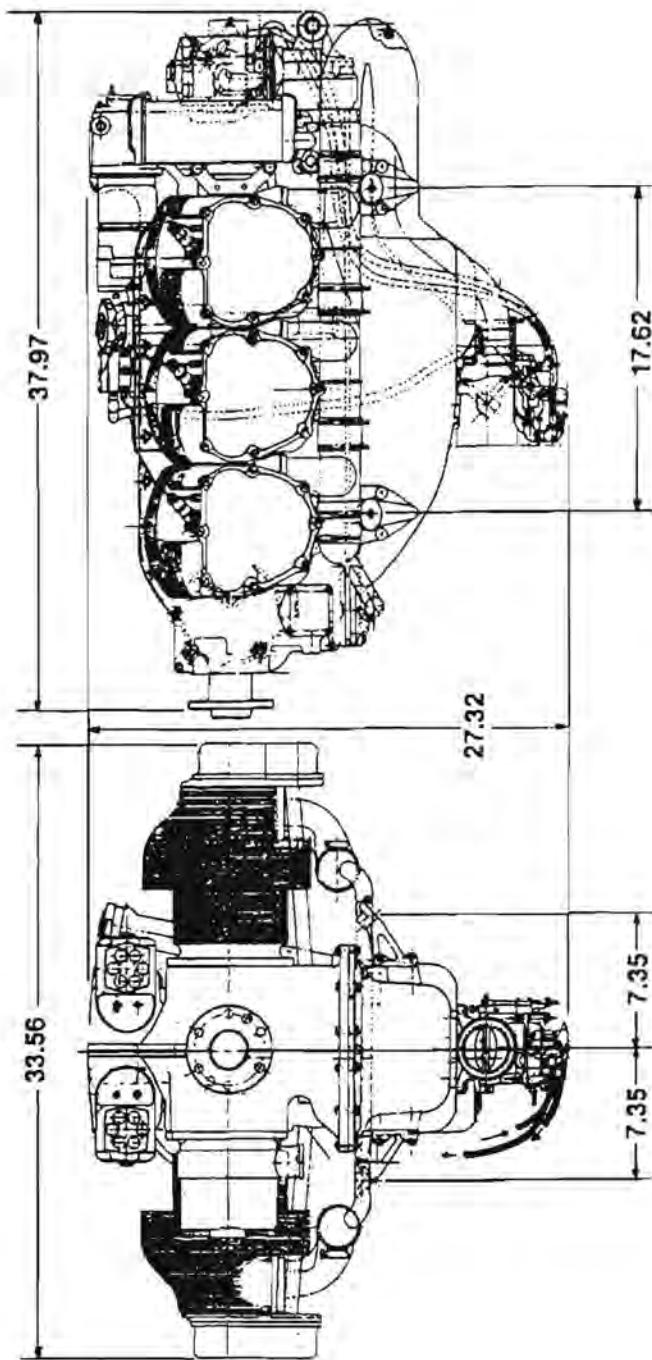

FIGURE 6-10-01. INSTALLATION DRAWING IO-520-B,BA,BB

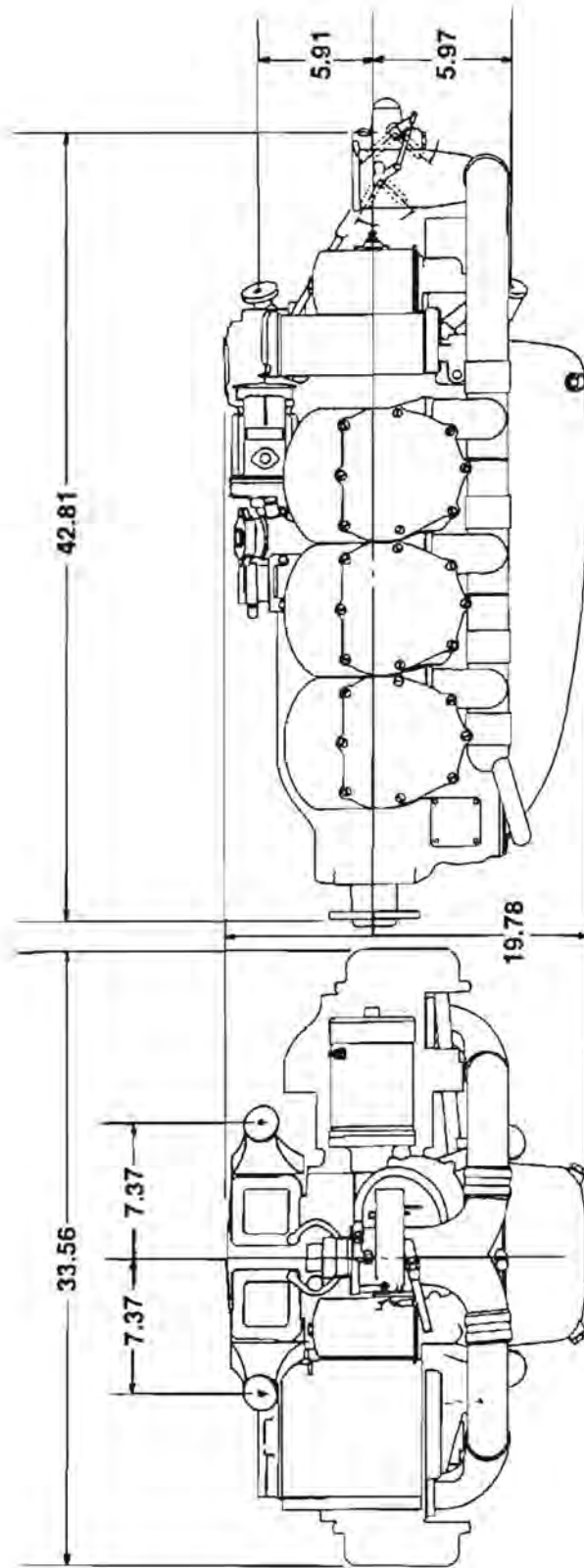

FIGURE 6-10-02. INSTALLATION DRAWING IO-520-C,CB



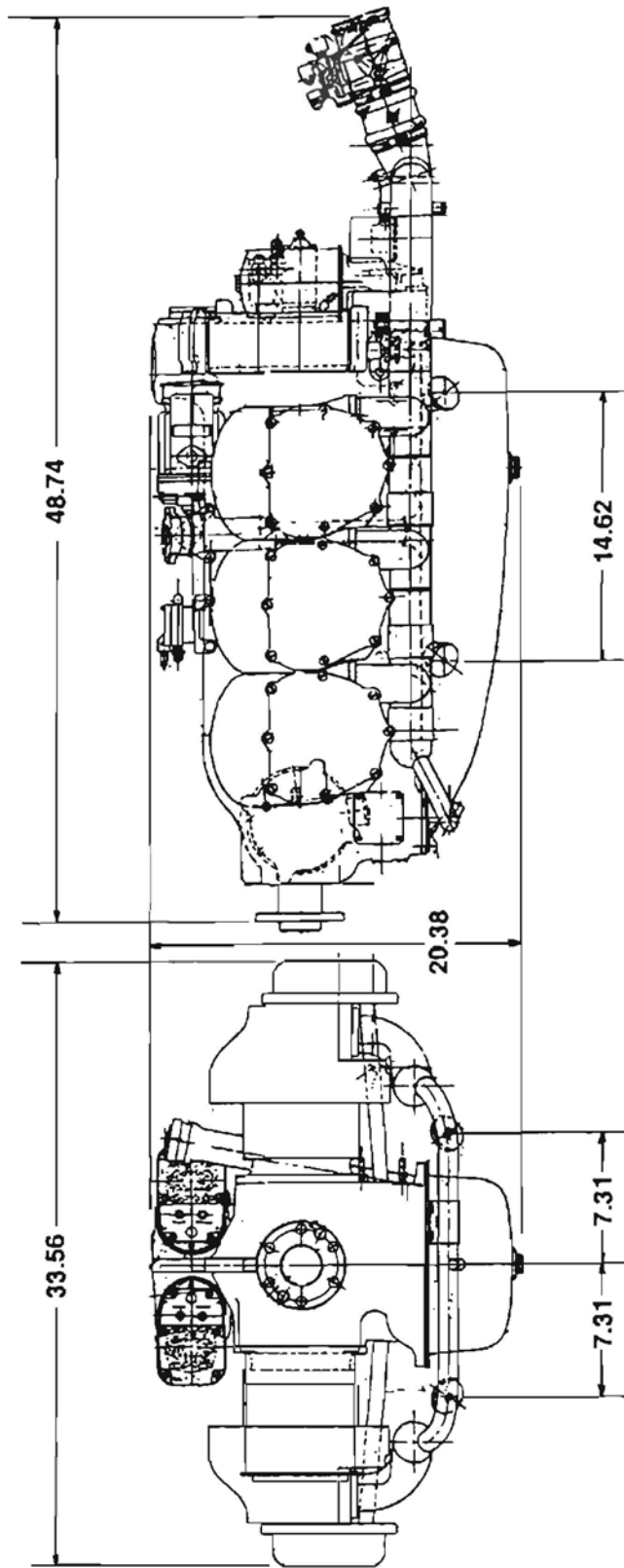

FIGURE 6-10-03. INSTALLATION DRAWING IO-520-M,MB

INTENTIONALLY

LEFT

BLANK

## 6-20-01 PREFLIGHT AND RUN-UP

The engine lubrication system must be pre-oiled prior to starting. This can be accomplished using a pressure oiling system installed into a main oil gallery or the oil pump. An acceptable alternate method is to use the engine starter to motor the engine with the spark plugs removed until an oil pressure indication is noted.

*CAUTION...Adhere to operating limits in Section 15-15-10 during flight testing.*

*CAUTION...Recheck the oil level in the sump if the pre-oiling method was used. Do not operate the engine with more or less than the required oil sump capacity. (See Operating Limits.)*

If the magneto attaching nuts were loosened or the magnetos rotated during engine installation, magneto to engine timing must be adjusted to specification prior to starting.

Install and torque the upper spark plugs to 300-360 in. lbs. Install the ignition harness "B" nuts to the spark plugs, nuts are identified for position, i.e. "1T" for number one top spark plug etc..

Start the engine in accordance with the procedures listed in SB 89-7 Rev. 1 or subsequent revision as applicable or the airframe manufacturer's operator's manual.

The engine has been tested at the factory and requires no further high power break-in on the ground. High power ground operation can be detrimental to cylinders, pistons, valves and rings.

**WARNING...Although the engine fuel system was adjusted at engine test the fuel system must be checked and adjusted in accordance with applicable TCM Overhaul Manual and current Service Bulletins when the engine is first installed into the aircraft to ensure proper operation. All discrepancies must be corrected prior to test flight.**

## 6-20-02 FLIGHT TESTING (Refer to Section 15-15-10 for Operating Data)

- The engine was tested prior to leaving the factory however, a short flight test is recommended to assure that the piston rings have seated and that no induction system, exhaust system, oil or fuel system leaks exist prior to releasing the aircraft for normal service.

*CAUTION...Adhere to operating limits in Section 15-15-10 during flight testing.*

Ambient air and engine operating temperatures are of major concern during this test flight. Accomplish a normal pre-flight run-up in accordance with the aircraft flight manual. Conduct a normal take-off with full power and monitor the fuel flow, RPM, oil pressure, cylinder head temperatures and oil temperatures. Reduce to climb power in accordance with the flight manual and maintain a shallow climb attitude to gain optimum airspeed and cooling. Rich mixture should be used for all operations except leaning for field elevation (where applicable) and leaning for cruise economy. Leaning operations should be performed in accordance with the airframe manufacturer's instructions.

Level flight cruise should be at 75% power with best power or richer mixture for the first hour of operation. During the second hour alternate power settings between 65% and 75% power with the appropriate best power mixture settings.

The descent should be made at low cruise power settings, with careful monitoring of engine pressures and temperatures. Avoid long descents with cruise RPM and manifold pressure below 18" Hg.; if necessary decrease the RPM sufficiently to maintain manifold pressure.

Any abnormal conditions detected during test flight must be corrected and any final adjustments must be accomplished prior to releasing the aircraft for normal service.

INTENTIONALLY

LEFT

BLANK

# CHAPTER 12

## SERVICING FLUIDS

### Section Index

| Section  |  | Page     |
|----------|--|----------|
| 12-00-01 | Servicing Oil . . . . .                    | 12-00-02 |
| 12-00-02 | Approved Engine Lubricating Oils . . . . . | 12-00-04 |
| 12-00-03 | Servicing Engine Fuel . . . . .            | 12-00-05 |

## 12-00-01 SERVICING OIL

The oil system must be serviced with the oil grades specified in this section and products conforming to MHS-24 or MHS-25. Refer to Section 12-00-02. It is essential that the required oil capacity be maintained.

A certain amount of oil consumption is normal. Consult section 15-15-01 of this manual to determine the acceptable rate of oil consumption. If excessive consumption or any abrupt change in rate of consumption is detected, this condition must be corrected before further flight.

Maintain the engine compartment, nacelle and the fuselage adjacent to the nacelle in a clean condition in order that an oil leak can be detected and corrected before further flight.

**WARNING...** Engine operation with no oil or severely reduced oil levels will cause engine malfunction or failure.

**CAUTION...** A greater number of funnel type quart oil containers incorporate a styrofoam seal. Do not puncture this seal and attempt servicing without totally removing the seal. Servicing an engine while this seal is still partially attached may result in ingestion of this seal into the engine and possible engine malfunction.

1. Check oil level before each flight and maintain oil level at the required capacity.
2. Examine the engine nacelle, engine compartment and adjacent area for oil leaks. Determine source and correct before further flight.
3. Ensure that the oil gage rod (dip stick) and filler cap are properly secured after servicing.

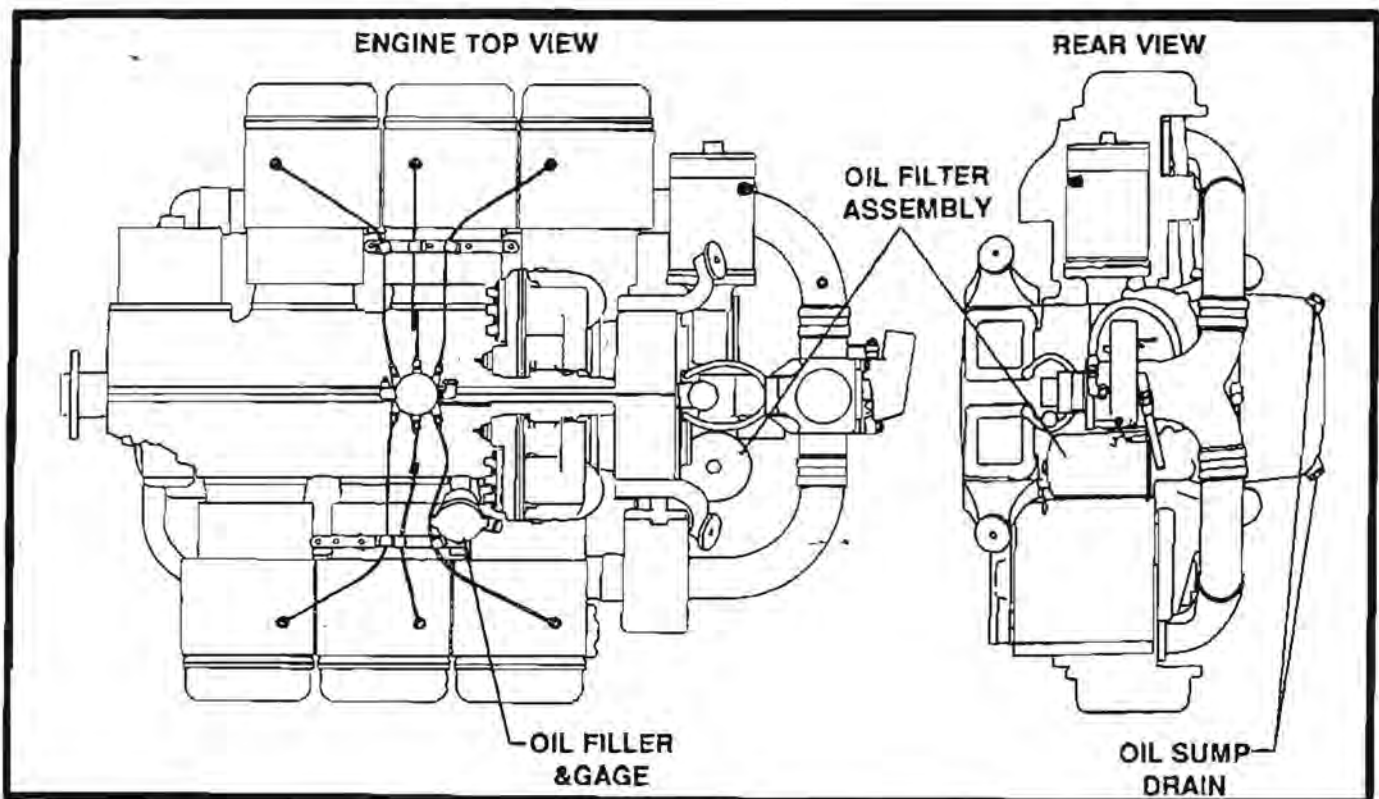

FIGURE 12-00-01. GENERAL IO-520 PERMOLD SERIES OIL SERVICING POINTS

During engine oil change, oil should be drained into an appropriate container and disposed of properly.

*CAUTION...Petroleum base aviation engine oil is flammable and should be stored in a well ventilated area away from any heat source.*

During servicing, if any oil is spilled it should be cleaned from the engine and nacelle.

Use only lubricating oils conforming to TCM specification MHS-24 or MHS-25. Refer to latest revision as applicable. See approved products on next page.

|   |                |
|---|----------------|
| Oil Sump Capacity: (U.S. Quarts) (All IO-520-Permold) . . . . . | 12 Quarts      |
| IO-520-B, BA, BB  |                |
| Usable Oil - Quarts 18° Nose Up . . . . .                       | 10.0           |
| Usable Oil - Quarts 14° Nose Down . . . . .                     | 10.0           |
| IO-520-C, CB  |                |
| Usable Oil - Quarts 20° Nose Up . . . . .                       | 6.5            |
| Usable Oil - Quarts 15° Nose Down . . . . .                     | 6.5            |
| IO-520-M, MB  |                |
| Usable Oil - Quarts 26° Nose Up . . . . .                       | 6.1            |
| Usable Oil - Quarts 13.5° Nose Down . . . . .                   | 6.1            |
| Oil Seasonal Weight   |                |
| All Temperatures . . . . .                                      | 15W50<br>20W50 |
| Below 40°F. Ambient Air (Sea Level) . . . . .                   | SAE30 or 10W30 |
| Above 40°F. Ambient Air (Sea Level) . . . . .                   | SAE 50         |

12-00-02 APPROVED ENGINE LUBRICATING OILS

Use only lubricating oils conforming to TCM specification MHS-24 or MHS-25, lubricating oil, ashless dispersant. The marketers of the aviation lubricating oils listed below have supplied data to TCM indicating their products conform to all the requirements of TCM Specification MHS-24 or MHS-25.

In listing the products names, TCM makes no claim of verification of marketer's statements or claims. Listing is made in the order in which the data was received by TCM and is provided only for the convenience of the users.

*CAUTION...The airframe manufacturer furnishes certain parts which depend on engine oil for lubrication and may restrict the use of some lubricating oils.*

| Supplier                        | Brand   |
|---------------------------------|---|
| MHS-25<br>Mobil Oil Company     | Mobil AV 1  |
| MHS-24<br>BP Oil Corporation    | BP Aero Oil   |
| Castrol Limited (Australia)     | Castrolaero AD Oil  |
| Chevron U.S.A. Inc.             | Chevron Aero Oil  |
| Continental Oil                 | Conco Aero S  |
| Delta Petroleum Company         | Delta Avoil Oil   |
| Exxon Company, U.S.A.           | Exxon Aviation Oil EE   |
| Gulf Oil Company                | Gulfpride Aviation AD   |
| Mobil Oil Company               | Mobil Aero Oil  |
| NYCO S.A.                       | TURBONYCOIL 3570  |
| Pennzoil Company                | Pennzoil Aircraft Engine Oil  |
| Phillips Petroleum Company      | Phillips 66 Aviation Oil, Type A  |
| Phillips Petroleum Company      | *X/C Aviation Multiviscosity Oil<br>SAE 20W50, SAE 20W60                              |
| Quaker State Oil & Refining Co. | Quaker State AD Aviation Engine Oil   |
| Red Ram Limited (Canada)        | Red Ram X/C Aviation Oil 20W50  |
| Shell Australia                 | Aeroshell (R) W   |
| Shell Canada Limited            | Aeroshell Oil W, Aeroshell Oil W 15W50<br>Anti-Wear Formulation Aeroshell Oil W 15W50 |
| Shell Oil Company               | Aeroshell Oil W, Aeroshell Oil W 15W50<br>Anti-Wear Formulation Aeroshell Oil W 15W15 |
| Sinclair Oil Company            | Sinclair Avoil  |
| Texaco Inc.                     | Texaco Aircraft Engine Oil - Premium AD   |
| Total France                    | Total Aero DM 15W50   |
| Union Oil Company of California | Union Aircraft Engine Oil HD  |

\*NOTE... This does not include X/C II Aviation Oil.

NOTE... For further information see TCM Service Bulletin M87-12R1 or current revision as applicable.



**12-00-03    SERVICING ENGINE FUEL**

Fuel Aviation Minimum Grade . . . . . 100LL (Blue) or 100 (Green)

**WARNING...The use of lower octane rated fuel will result in destruction of an engine the first time high power is applied. This would most likely occur on takeoff. If the aircraft is inadvertently serviced with the wrong grade of fuel, then the fuel must be completely drained and the tank properly serviced.**

For aircraft fueling procedure, see the applicable aircraft manufacturer's instructions (Fueling Procedure and Fueling Point).

INTENTIONALLY

LEFT

BLANK

**CHAPTER 14**  
**ENGINE PRESERVATION AND**  
**STORAGE**

**Section Index**

| <b>Section</b> |  | <b>Page</b> |
|----------------|--|-------------|
| 14-00-00       | General . . . . .                                  | 14-00-02    |
| 14-00-01       | Engine Preservation . . . . .                      | 14-00-02    |
| 14-00-02       | Fiyable Storage (5 to 30 days) . . . . .           | 14-00-02    |
| 14-00-03       | Temporary Storage (up to 90 days) . . . . .        | 14-00-03    |
| 14-00-04       | Indefinite Storage . . . . .                       | 14-00-04    |
| 14-00-05       | Returning Engine To Service . . . . .              | 14-00-05    |
| 14-00-06       | Indefinite Storage Inspection Procedures . . . . . | 14-00-06    |

## 14-00-00 GENERAL

The following procedures are a general recommendation for our customers. Since local weather conditions differ and Teledyne Continental Motors has no control over the application, more stringent procedures may be required. Rust and corrosion prevention are the owner's responsibility.

## 14-00-01 ENGINE PRESERVATION

Engines in aircraft that are flown only occasionally tend to exhibit cylinder wall corrosion more than engines in aircraft that are flown frequently.

Of particular concern are new engines or engines with new or freshly honed cylinders after a top or major overhaul. In areas of high humidity, there have been instances where corrosion has been found in such cylinders after an inactive period of only a few days. When cylinders have been operated for approximately 50 hours, the varnish deposited on the cylinder walls offers some protection against corrosion. Hence, a two step program for flyable storage category is required.

Obviously, proper steps must be taken on engines used infrequently to lessen the possibility of corrosion. This is especially true if the aircraft is based near the sea coast or in areas of high humidity and flown less than once a week.

In all geographical areas the proven method of preventing corrosion of the cylinders and other internal parts of the engine is to fly the aircraft at least once a week, long enough to reach normal operating temperatures which will vaporize moisture and other by-products of combustion. However, if circumstances do not permit this required procedure, TCM has listed three reasonable minimum preservation procedures that, if implemented, will minimize the possibilities of rust and corrosion. It is the owner's responsibility to choose a program that is viable to the particular aircraft's mission.

Aircraft engine storage recommendations are broken down into the following categories:

| Section  |                                   |
|----------|-----------------------------------|
| 14-00-02 | Flyable Storage (5 to 30 days)    |
| 14-00-03 | Temporary Storage (up to 90 days) |
| 14-00-04 | Indefinite Storage                |

## 14-00-02 FLYABLE STORAGE (Program I or II)

Program I - Engines or cylinders with less than 50 operating hours:

- a. Propeller pull thru every 5 days as described in paragraph 2 below and
- b. Fly every 15 days as described in paragraph 3 below.

Program - II Engines or cylinders with more than 50 operating hours if not flown weekly:

- a. Propeller pull thru every 7 days as described in paragraph 2 below and
- b. Fly every 30 days as described in paragraph 3 below.

1. Service aircraft per normal airframe manufacturer's instructions.
2. The propeller should be rotated by hand without running the engine. For 6 cylinder straight drive engines, rotate the propeller six revolutions. Stop the propeller 45° to 90° from the original position.

**WARNING...To prevent possibility of serious bodily injury or death, before moving the propeller accomplish the following:**

- a. **Verify magneto switches are "OFF".**
  - b. **Throttle position "CLOSED".**
  - c. **Mixture control "IDLE-CUT-OFF".**
  - d. **Set brakes and block aircraft wheels.**
  - e. **Assure that aircraft tie-downs are installed and verify that the cabin door latch is open.**
  - f. **Do not stand within the arc of the propeller blades while turning the propeller.**
3. The aircraft should be flown for thirty (30) minutes reaching, but not exceeding, normal oil and cylinder temperatures. If the aircraft cannot be flown it should be preserved in accordance with the instructions set forth in Temporary Storage section 14-00-03 or Indefinite Storage section 14-00-04. Ground running is not an acceptable substitute for flying.

It is necessary that for future reference the propeller pull thru and flight time be recorded and verified in the engine maintenance record/log with the date, time and signature of the individual performing these procedures.

#### **14-00-03 TEMPORARY STORAGE (up to 90 days)**

1. Preparation for storage.
  - a. Remove the top spark plug and spray atomized preservative oil (Lubrication Oil-Contact and Volatile Corrosion-Inhibited, MIL-L-46002, Grade 1) at room temperature through upper spark plug hole of each cylinder with the piston in approximately the bottom dead center position. Rotate crankshaft as opposite cylinders are sprayed. Stop crankshaft with none of the pistons at top dead center.

NOTE...Shown below is the preservative oil recommended for use in Teledyne Continental engines for temporary and indefinite storage:

MIL-L-46002, Grade 1 Oil

NOX RUST VC1-105      May be purchased through:  
Rock Island Lubricant & Chemical Co.  
P.O. Box 5015  
1320 1st Street  
Rock Island, Illinois 61204  
1-800-522-1150

- b. Re-spray each cylinder. To thoroughly cover all surfaces of the cylinder interior, move the nozzle or spray gun from the top to the bottom of the cylinder.
- c. Install spark plugs.
- d. Spray preservative oil (approximately two ounces) through the oil filler tube.
- e. Seal all engine openings exposed to the atmosphere using suitable plugs or moisture resistant tape.

- f. Engines with propellers installed that are preserved for storage in accordance with this section should have a tag affixed to each propeller in a conspicuous place with the following notation on the tag: "DO NOT TURN PROPELLER - ENGINE PRESERVED" PRESERVATION DATE \_\_\_\_\_.

NOTE ...If the engine is not returned to flyable status on or before the expiration of 90 days, it must be preserved in accordance with the Indefinite Storage procedures set forth in section 14-00-04 below.

## 2. Preparation for Service

- a. Remove seals, tape, paper and streamers from all openings.
- b. With bottom spark plugs removed, rotate the propeller by hand several revolutions to remove preservative oil; re-install spark plugs.

**WARNING...To prevent possibility of serious bodily injury or death, before moving the propeller accomplish the following:**

- a. Verify magneto switches are "OFF".
  - b. Throttle position "CLOSED".
  - c. Mixture control "IDLE-CUT-OFF".
  - d. Set brakes and block aircraft wheels.
  - e. Assure that aircraft tie-downs are installed and verify that the cabin door latch is open.
  - f. Do not stand within the arc of the propeller blades while turning the propeller.
- c. Conduct a normal engine start.
  - d. Give the aircraft a thorough cleaning and visual inspection. Conduct a test flight per airframe manufacturer's recommendation.

## 14-00-04 INDEFINITE STORAGE

### 1. Preparation for storage.

- a. Drain the engine oil and refill with MIL-C-6529 Type II (Aeroshell Fluid 2F or equivalent). The aircraft should be flown for thirty (30) minutes reaching, but not exceeding normal oil and cylinder temperatures. Allow engine to cool to ambient temperature. Accomplish steps "1.a." and "1.b." of Temporary Storage.

NOTE...MIL-C-6529 Type II may be formulated by thoroughly mixing one part compound MIL-C-6529 Type I (Esso Rust-Ban 628, Cosmoline No. 1223 or equivalent) with three parts new lubricating oil of the grade recommended for service (all at room temperature). Single grade oil is recommended.

- b. Apply preservative to engine interior by spraying MIL-L-46002, Grade I oil (approximately two ounces) through the oil filler tube.
- c. Install dehydrator plugs MS27215-1 or -2 in each of the top spark plug holes making sure that each plug is blue in color when installed. Protect and support the spark plug leads with AN-4060 protectors.
- d. The TCM fuel injection system does not require any special preservation preparation.

- e. Place a bag of desiccant in the exhaust pipes and seal the openings with moisture resistant tape.
- f. Seal the cold air inlet to the heater muff with moisture resistant tape to exclude moisture and foreign objects.
- g. Seal the engine breather by inserting a dehydrator MS2721 5-2 plug in the breather hose and clamping in place.
- h. Attach a red streamer to each place on the engine where bags of desiccant are placed. Either attach red streamers outside of the sealed area with tape or to the inside of the sealed area with safety wire to prevent wicking of moisture into the sealed area.
- i. Engines with propellers installed that are preserved for storage in accordance with this section should have each propeller tagged in a conspicuous place with the following notation on the tag: "DO NOT TURN PROPELLER - ENGINE PRESERVED", - PRESERVATION DATE \_\_\_\_\_

**14-00-05 PROCEDURES NECESSARY FOR RETURNING AN ENGINE TO SERVICE ARE AS FOLLOWS:**

1. Remove the cylinder dehydrator plugs and all paper, tape, desiccant bags and streamers used to preserve the engine.
2. Drain the corrosion preventive mixture and re-service with recommended lubricating oil.

*CAUTION... When returning the aircraft to service do not use the oil referenced in section 14-00-04 for more than 25 hours.*

3. With bottom plugs removed, rotate propeller by hand to clear excess preservative oil from cylinders.

**WARNING...To prevent possibility of serious bodily injury or death, before moving the propeller accomplish the following:**

- a. Verify magneto switches are "OFF".
  - b. Throttle position "CLOSED".
  - c. Mixture control "IDLE-CUT-OFF".
  - d. Set brakes and block aircraft wheels.
  - e. Assure that aircraft tie-downs are installed and verify that the cabin door latch is open.
  - f. Do not stand within the arc of the propeller blades while turning the propeller.
4. Re-install the spark plugs and rotate the propeller by hand through the compression strokes of all the cylinders to check for possible liquid lock. Start the engine in the normal manner.
  5. Clean aircraft thoroughly and conduct a visual inspection of the aircraft. Conduct a test flight per airframe manufacturer's instructions.

## 14-00-06 INDEFINITE STORAGE INSPECTION PROCEDURES

1. Aircraft prepared for Indefinite Storage must have the cylinder dehydrator plugs visually inspected every 15 days. The plugs should be changed as soon as they indicate other than a dark blue color. If the dehydrator plugs have changed color in one-half or more of the cylinders, all desiccant material on the engine should be replaced.
2. The cylinder bores of all engines prepared for Indefinite Storage must be re-sprayed with corrosion preventive mixture every six months, or more frequently if bore inspection indicates corrosion has started earlier than six months. Replace all desiccant and dehydrator plugs. Before spraying, the engine should be inspected for corrosion as follows. Inspect the interior of at least one cylinder through the spark plug hole. If the cylinder shows start of rust, spray cylinder corrosion preventive oil conforming to MIL-L-46002, Grade 1 and rotate propeller by hand over six times, then re-spray all cylinders. Remove at least one rocker box cover and inspect the valve mechanism for any type of corrosion.

**WARNING...**To prevent possibility of serious bodily injury or death, before moving the propeller accomplish the following:

- a. Verify magneto switches are "OFF".
- b. Throttle position "CLOSED".
- c. Mixture control "IDLE-CUT-OFF".
- d. Set brakes and block aircraft wheels.
- e. Assure that aircraft tie-downs are installed and verify that the cabin door latch is open.
- f. Do not stand within the arc of the propeller blades while turning the propeller.

*CAUTION...* When returning the aircraft to service do not use the oil referenced in section 14-00-04 for more than 25 hours.

The above procedures are general specifications for rust and corrosion prevention. Since local weather conditions differ and Teledyne Continental Motors has no control over the application, more stringent procedures may be required. Rust and corrosion prevention are the owner's responsibility.



# CHAPTER 15 ENGINE OPERATING PROCEDURES

## NORMAL OPERATING PROCEDURES

### Section Index

| Section  |                                       | Page     |
|----------|---------------------------------------|----------|
| 15-00-00 | General . . . . .                     | 15-00-03 |
| 15-00-01 | Prestarting . . . . .                 | 15-00-03 |
| 15-00-02 | Starting . . . . .                    | 15-00-03 |
| 15-00-03 | Cold Starts . . . . .                 | 15-00-04 |
| 15-00-04 | Flooded Engine . . . . .              | 15-00-04 |
| 15-00-05 | Hot Starts . . . . .                  | 15-00-04 |
| 15-00-06 | Ground Warm Up . . . . .              | 15-00-04 |
| 15-00-07 | Pre Takeoff Check . . . . .           | 15-00-05 |
| 15-00-08 | Power Control . . . . .               | 15-00-06 |
| 15-00-09 | Takeoff . . . . .                     | 15-00-07 |
| 15-00-10 | Climb . . . . .                       | 15-00-07 |
| 15-00-11 | Cruise . . . . .                      | 15-00-08 |
| 15-00-12 | Descent . . . . .                     | 15-00-08 |
| 15-00-13 | Landing . . . . .                     | 15-00-08 |
| 15-00-14 | Engine Shutdown . . . . .             | 15-00-09 |
| 15-00-15 | Operational Troubleshooting . . . . . | 15-00-09 |

### EMERGENCY PROCEDURES

|          |  |          |
|----------|--|----------|
| 15-05-01 | Engine Fires During Start . . . . .      | 15-05-01 |
| 15-05-02 | General In-Flight Information . . . . .  | 15-05-01 |
| 15-05-03 | Engine Roughness . . . . .               | 15-05-01 |
| 15-05-04 | High Cylinder Head Temperature . . . . . | 15-05-02 |
| 15-05-05 | High Oil Temperature . . . . .           | 15-05-02 |
| 15-05-06 | Low Oil Pressure . . . . .               | 15-05-02 |
| 15-05-07 | In-Flight Restarting . . . . .           | 15-05-02 |
| 15-05-08 | Engine Fire in-Flight . . . . .          | 15-05-03 |

## ABNORMAL ENVIRONMENTAL CONDITIONS

| Section  |  | Page     |
|----------|--|----------|
| 15-10-00 | General . . . . .                              | 15-10-01 |
| 15-10-01 | Cold Weather Operation . . . . .               | 15-10-01 |
| 15-10-02 | Preheating . . . . .                           | 15-10-01 |
| 15-10-03 | Hot Weather Operation . . . . .                | 15-10-03 |
| 15-10-04 | Ground Operation At High Altitude Airports . . | 15-10-04 |

## ENGINE PERFORMANCE AND CRUISE CONTROL

|          |   |          |
|----------|---|----------|
| 15-15-01 | Operating Data . . . . .                      | 15-15-01 |
| 15-15-02 | Cruise Control By Performance Curve . . . . . | 15-15-02 |
| 15-15-03 | Cruise Control By EGT . . . . .               | 15-15-02 |
| 15-15-04 | Table of Performance Curves . . . . .         | 15-15-03 |

## 15-00-00 GENERAL

*CAUTION...This section pertains to operation under standard environmental conditions. The pilot should thoroughly familiarize himself with Section 15-10, Abnormal Environmental Conditions. Whenever such abnormal conditions are encountered or anticipated, the procedures and techniques for normal operation should be tailored accordingly.*

The life of your engine is determined by the care it receives. Follow the instructions contained in this manual carefully.

The engine received a run-in operation before leaving the factory. Therefore, no break-in schedule is required. Straight mineral oil (MIL-C-6529 Type II) should be used for the first oil change period (25 hours).

The minimum grade aviation fuel for this engine is 100LL (Blue) or 100 (Green). If the minimum grade required is not available, use a higher rating. Never use a lower rated fuel.

**WARNING...The use of a lower octane rated fuel will cause pre-ignition and/or detonation which can damage an engine the first time high power is applied, possibly causing engine failure. This would most likely occur on takeoff. If the aircraft is inadvertently serviced with the wrong grade of fuel, then the fuel must be completely drained and the tank properly serviced prior to engine operation.**

### 15-00-01 PRESTARTING (Refer to Pilot's Operating Handbook for Prestarting Procedures)

Before each flight the engine and propeller must be examined for damage, oil or fuel leaks, security and proper servicing.

**WARNING...Before moving the propeller by hand, insure the magneto circuit is functioning properly and the switch is in the "OFF" position. Moving the propeller by hand with a malfunctioning magneto or ignition circuit may cause the engine to kick over or start resulting in injury to personnel.**

### 15-00-02 STARTING (Refer to Pilot's Operating Handbook for Starting Procedures)

**WARNING...Overpriming can cause hydro static lock and subsequent engine malfunction.**

*CAUTION...If engine is hot, press starter button first, then turn auxiliary fuel pump as instructed by the airframe manufacturer.*

*CAUTION...Release starter switch as soon as engine fires. Never engage the starter while the propeller is still turning. If the starter has been engaged for 30 seconds and the engine has not been started, release the starter switch and allow the starter motor to cool for 3 to 5 minutes before another starting attempt is made.*

**NOTE...Check oil pressure frequently. Oil pressure indication must be noted within 30 seconds in normal weather. If no pressure is noted within the specified time, stop the engine and investigate the cause.**

*CAUTION...Operation of the engine without oil pressure may result in engine malfunction or failure.*

**15-00-03 COLD STARTS (Refer to Pilot's Operating Handbook)**

Use the same procedure as for normal start. After the engine begins running, it may be necessary to operate the primer intermittently for a few seconds in order to prevent the engine from stopping.

**15-00-04 FLOODED ENGINE (Refer to Pilot's Operating Handbook)**

**Allow all fuel to drain from Intake system before attempting to start a flooded engine.**

**WARNING...Starting an engine with a flooded intake system will result in hydrostatic lock and subsequent engine malfunction or failure.**

**15-00-05 HOT STARTS (Refer to Pilot's Operating Handbook)**

For several minutes (10 to 45) after stopping a hot engine, heat soaked fuel injection components, (especially the fuel injection pump) may cause vaporization of fuel in the components resulting in difficulty restarting the engine. To eliminate this difficulty, the following procedures must be used to cool the fuel pump and lines prior to restart.

Turn fuel selector to "ON". Bring throttle to the "CLOSED" position. Put mixture control to the "Idle Cut Off" position and run boost pump for 15 to 20 seconds. Turn boost pump "OFF". Perform a normal start procedure. See Section 15-00-02.

**15-00-06 GROUND WARM-UP**

Teledyne Continental aircraft engines are aircooled and are dependent on the forward speed of the aircraft for cooling. To prevent overheating, it is important that the following rules be observed.

1. Head the aircraft into the wind.
2. Operate the engine on the ground with the propeller in "Full Increase" RPM position.
3. Avoid prolonged idling at low RPM. Fouled spark plugs can result from this practice.
4. Leave mixture in "Full Rich". See "Ground Operation at High Altitude Airports" Section 15-10-04, for exceptions.
5. Warm-up engine at 900-1000 RPM.

**15-00-07 PRE-TAKEOFF CHECK (Refer to Pilot's Operating Handbook)**

1. Maintain engine speed at approximately 900 to 1000 RPM for at least one minute in warm weather, and as required during cold weather (see Section 15-10-01) to assure adequate lubrication.
2. Advance throttle slowly until tachometer indicates an engine speed of approximately 1200 RPM. Allow additional warm-up time at this speed depending on ambient temperature. This time may be used for taxiing to takeoff position. The minimum allowable oil temperature for run-up is 75°F.

*CAUTION...Do not operate the engine at run-up speed unless oil temperature is 75°F minimum and oil pressure is within specified limits of 30-60 PSI.*

*CAUTION...Operation of the engine at too high a speed before reaching minimum oil temperature may cause loss of oil pressure and engine damage.*

3. Perform all ground operations with cowling flaps, if installed, full open with mixture control in "FULL RICH" position and propeller control set for maximum RPM (except for brief testing of propeller governor).
4. Restrict ground operations to the time necessary for warm-up and testing.
5. Increase engine speed to 1700 RPM only long enough to perform the following checks:
  - a. Check magnetos: Move the ignition switch first to "R" position and note engine RPM. Then move switch back to "BOTH" position to clear the other set of spark plugs. Then move the switch to "L" position and note RPM. The difference between the two magnetos operated individually should not differ more than 50 RPM with a maximum drop for either magneto of 150 RPM. Observe engine for roughness during this check.

**WARNING...Absence of RPM drop when checking magnetos may indicate a malfunction in the ignition circuit resulting in a hot magneto. Should the propeller be moved by hand (as during preflight) the engine may start and cause injury to personnel. This type of malfunction must be corrected prior to continued operation of the engine.**

*CAUTION...Do not underestimate the importance of pre-takeoff magneto check. When operating on single ignition, some RPM drop should be noted. Normal indications are 25-75 RPM drop and slight engine roughness as each magneto is switched off. An RPM drop in excess of 150 RPM may indicate a faulty magneto or fouled spark plugs.*

Minor spark plug fouling can usually be cleared as follows:

- (1) Magnetos - Both On.
- (2) Throttle - 2200 RPM.
- (3) Mixture - Move toward idle cutoff until RPM peaks and hold for ten seconds. Return mixture to full rich.
- (4) Magnetos - Recheck.

If the engine is not operating within specified limits, it must be inspected and repaired prior to continued operation of the engine.

*CAUTION...Avoid prolonged single magneto operation to preclude fouling of the spark plugs.*

- b. Check throttle and propeller operation.

Move propeller governor control toward low RPM position and observe tachometer. Engine speed should decrease to minimum governing speed or as specified by the Airframe Manufacturer. Return governor control to high speed position. Repeat this procedure two or three times to circulate warm oil into the propeller hub.

Where applicable move propeller control to "feather" position. Observe for RPM drop below minimum governing RPM. Then return control to "full increase" RPM position in accordance with the airframe manufacturer's instructions.

*CAUTION...Do not operate the engine at a speed in excess of 2000 RPM longer than necessary to test operation and observe engine instruments. Proper engine cooling depends upon forward speed of the aircraft. Discontinue testing if temperature or pressure limits are approached.*

6. Instrument Indications. (Refer to Pilot's Operating Handbook)

#### 15-00-08 POWER CONTROL

When increasing power, first increase the RPM with the propeller control and then increase manifold pressure with throttle. When decreasing power, throttle back to desired manifold pressure and then adjust to the desired RPM. Readjust manifold pressure after final RPM setting.

**15-00-09 TAKEOFF (Refer to Airframe Manufacturer's recommendations.)**

1. Position mixture to "FULL RICH". Where installed, cowl flaps must be positioned as specified by airframe manufacturer.
2. Position fuel boost pump switch as instructed by airframe manufacturer.
3. Use full throttle to obtain rated power for takeoff. During takeoff, observe manifold pressure, RPM, fuel flow, engine temperature and oil pressure. All must be within normal limits.

**NOTE...**For operation from fields at higher altitudes, operation must be conducted with the mixture control leaned for maximum performance as defined by charts in section 15-15-04 or by an appropriately marked fuel pressure gauge. A leaner than full rich mixture may be required to eliminate engine roughness.

**CAUTION...***Cylinder head and oil temperatures must never be allowed to exceed the limitations specified. Near-maximum temperatures should occur only when operating under adverse conditions, such as high power settings, low airspeed, extreme ambient temperature, etc.. Steps should be taken to reduce such temperatures as soon as possible. If excessive temperatures are noted and cannot be explained, or if abnormal cowl flap and/or mixture settings are required to maintain temperatures, then an inspection must be performed to determine the cause. Possible causes of high temperatures may include broken or missing baffles, inoperative cowl flaps, sticking oil temperature control unit, or restricted fuel nozzle jets (resulting in lean-running cylinders). Faulty instruments or thermocouples may cause erroneously high (or low) temperature indications. Refer to 15-00-15 of this manual and/or the aircraft overhaul manual for trouble shooting procedures.*

**15-00-10 CLIMB (Refer to Airframe Manufacturer's recommendations.)**

1. Recommended power for normal climb is 75%.
2. Climb at 75% power and above must be done at "FULL RICH" mixture setting with cowl flaps, if installed, set to maintain proper cylinder head and oil temperature.
3. During climb (immediately after takeoff) observe manifold pressure, RPM, fuel flow, engine temperature and oil pressure. All should be within limits.

**NOTE...**When the aircraft has been configured for climbout, reduce engine power. If power settings of greater than 75% Normally Rated Power (NRP) must be used, particular attention must be given to cylinder head, EGT, and oil temperatures, and mixture must be "FULL RICH".

**WARNING...**At power settings above 75% NRP, do not use the EGT gage as an aid to mixture adjustment. If you attempt to determine the "peak" EGT while the engine is operating at high power, burned valves, detonation, and engine failure can occur.

**15-00-11 CRUISE (Refer to Airframe Manufacturer's recommendations.)**

1. Set manifold pressure and RPM for cruise power selected.
2. After engine temperatures have stabilized at cruise condition (usually within 5 minutes), adjust mixture to lean cruise condition according to Section 15-15-03 of this manual.

NOTE...During high ambient temperature, a very low fluctuation in fuel flow may appear in the early flight stages, which is caused by excess vapor. If this occurs, operate the fuel boost pump as recommended by the airframe manufacturer.

3. When a lean mixture setting is used, for cruise, and increased power is desired, the mixture control must be returned to the richer setting before changing the throttle or propeller setting. When reducing power, retard throttle and then adjust RPM and mixture.
4. If it is necessary to retard the throttles at altitudes above 10,000 Ft., leaning of the fuel mixture may also be necessary to maintain satisfactory engine operation. The mixture must be returned to the richer setting before the throttle is returned to the high power position.

NOTE...Exhaust gas temperature may be used as an aid for mixture setting. Refer to Section 15-15-03 for leaning information.

**15-00-12 DESCENT (Refer to Airframe Manufacturer's recommendations)**

Descent from high altitude is to be accomplished at cruise power settings and mixture control positioned for engine smoothness.

*CAUTION...Rapid descents at high RPM and idle manifold pressure setting are to be avoided.*

During descent, monitor cylinder and oil temperature and maintain above the minimum specified limits.

NOTE...Avoid long descents at low manifold pressure as the engine can cool excessively and may not accelerate satisfactorily when power is reapplied. If power must be reduced for long periods, adjust propeller to minimum governing RPM and set manifold pressure no lower than necessary to obtain desired performance. If the outside air is extremely cold, it may be desirable to add drag to the aircraft in order to maintain engine power without gaining excess airspeed. Do not permit cylinder temperature to drop below 300°F for periods exceeding five (5) minutes.

**15-00-13 LANDING (Refer to Airframe Manufacturer's recommendations.)**

1. In anticipation of a go around and the need for high power settings, the mixture control must be set in the "FULL RICH" position before landing.

NOTE...Advance mixture slowly toward "FULL RICH". If engine roughness occurs, as may happen at very low throttle settings and high RPM, it may be desirable to leave the mixture control in a leaner than full rich position until the throttles are advanced above 15 inches of manifold pressure.

2. Operate the boost pump as instructed by the airframe manufacturer.



## 15-00-14 ENGINE SHUTDOWN

1. If boost pump has been on for landing, turn to "OFF".
2. Place mixture control in "IDLE CUTOFF".
3. Turn magnetos "OFF" after propeller stops rotating.

**WARNING...Do not turn the propeller while the Ignition switch is in the "BOTH", "LEFT" or "RIGHT" position. This could start the engine and cause serious bodily injury or death. Do not turn the propeller on a hot engine, even though the ignition switch is "OFF" position. The engine could "KICK" as a result of auto-ignition of small amount of fuel remaining in the cylinders.**

## 15-00-15 OPERATIONAL TROUBLESHOOTING

General Information.

**WARNING...If during pre-flight check, engine warm up, any operational limit abnormalities occur, abort take-off, return to aircraft maintenance facility and have symptoms investigated and corrected by qualified personnel before flight.**

The troubleshooting chart that follows will discuss some symptoms and corrections that can be corrected on the ground and in-flight. Other situations are discussed in the engine maintenance manual, X30625A.

## OPERATIONAL TROUBLE SHOOTING CHART.

This Troubleshooting chart is provided as a guide. Review all probable causes given, then check other listings of troubles with similar symptoms.

| TROUBLE                                | PROBABLE CAUSE   | CORRECTION   |
|--|--|--|
| Engine Will Not Run at Idling Speed    | Propeller levers set in high pitch (Decrease RPM)              | Use low pitch (Increase RPM) position for all ground operation.                                    |
| Rough Idling                           | Mixture levers set for improper mixture                        | Use FULL RICH position for all ground operation.   |
| Engine Runs Too Lean at Cruising Power | Improper manual leaning procedure                              | Refer to Section 15-15-04 for proper fuel flow settings.   |
| High Cylinder Head Temperature         | Lean fuel/air mixture due to improper manual leaning procedure | Refer to Section 15-15-04 for proper fuel flow settings.   |
| Fluctuating Fuel Pressure              | Vapor in fuel system. Excessive fuel temperature               | Operate auxiliary pump if equipped and purge system.   |
| High Oil Temperature Indication        | Prolonged ground operation                                     | Limit ground operation to a minimum.   |
| Poor Idle Cut-Off                      | Engine receiving fuel after engine shutdown                    | Check mixture control is in full idle cut-off. Check auxiliary pump is off.                        |
| Slow Acceleration On A Hot Day         | Mixture Too Rich   | Momentarily pull mixture control back until engine acceleration picks up, then set proper mixture. |

### 15-05-01 ENGINE FIRE DURING START(Refer to Airframe Manufacturer's recommendations.)

If flames are observed in the induction or exhaust system during engine starting, proceed as follows:

1. Mixture Control - Move to the idle cut-off position.
2. Throttle Control - Move to the full open position.
3. Starter Switch - Hold in the cranking position until fire is extinguished.
4. Inspect for and repair damage before further flight.

### 15-05-02 GENERAL IN-FLIGHT INFORMATION

If a malfunction should occur in flight, certain remedial actions may eliminate or reduce the problem. Some malfunctions which might conceivably occur are listed in this chapter. Recommended corrective action is also included. However, it should be recognized that no single procedure will necessarily be applicable to every situation.

A thorough knowledge of the aircraft and engine systems will be an invaluable asset to the pilot in assessing a given situation and dealing with it appropriately.

### 15-05-03 ENGINE ROUGHNESS

Observe engine area for visible damage or evidence of smoke or flame. Extreme roughness may be indicative of a propeller blade problem. If any of these are noted, follow airframe manufacturer's instructions.

1. Mixture - Adjust as appropriate to power setting being used. Do not immediately go to Full Rich as the roughness may be caused by an overrich mixture.
2. Magneto Switch - Check "Both" or "On".

If engine roughness does not disappear after the above, the following steps should be taken to evaluate the ignition system.

1. Throttle - Reduce power until roughness becomes minimal.
2. Perform Magneto Check - If engine smooths out while running on single ignition, adjust power as necessary. Do not operate the engine in this manner any longer than absolutely necessary. The airplane should be landed as soon as practical for engine repairs.

If no improvement in engine operation is noted while operating on either magneto alone, return magneto switch to "Both" or "On".

*CAUTION...The engine may quit completely when one magneto is switched off if the other magneto is faulty. If this happens, close throttle to idle and move mixture to idle cutoff before turning magnetos on. This will prevent a severe backfire. When magnetos have been turned back on, advance mixture and throttle to previous setting.*

**WARNING...**If roughness is severe or if the cause cannot be determined, engine failure may be imminent. In this case, it is recommended that the airframe manufacturer's emergency procedure be employed. In any event, further damage may be minimized by operating at a reduced power setting.

## ABNORMAL ENGINE INSTRUMENT INDICATIONS

### 15-05-04 HIGH CYLINDER HEAD TEMPERATURE

1. Cowl Flaps - Open.
2. Mixture - Adjust to proper fuel flow for power being used.
3. Airspeed - Increase.

If temperature cannot be maintained within limits, reduce power, land as soon as practical and have the malfunction evaluated and repaired before further flight.

### 15-05-05 HIGH OIL TEMPERATURE

**NOTE...**Prolonged high oil temperature indications will usually be accompanied by a drop in oil pressure. If oil pressure remains normal, a high temperature indication may be caused by a faulty gage or thermocouple. If the oil pressure drops as temperature increases, proceed as follows:

1. Cowl Flaps - Open.
2. Airspeed - Increase.
3. Power - Reduce if steps 1 and 2 do not lower oil temperature.

**CAUTION...***If these steps do not restore oil temperature to normal, an engine failure or severe damage can result. In this case it is recommended that the airframe manufacturer's emergency instructions be followed.*

### 15-05-06 LOW OIL PRESSURE

- If the oil pressure drops without apparent reason from a normal indication of 30 to 60 psi, monitor temperature and pressure closely, land as soon as possible and have the engine inspected at termination of the flight.

**WARNING...***If oil pressure drops below 30 PSI, an engine failure should be anticipated and the airframe manufacturer's instructions should followed.*

### 15-05-07 IN-FLIGHT RESTARTING (Refer to Airframe Manufacturer's Instructions for emergency / Inflight restarting.)

**CAUTION...***Do not shutdown an engine for practice or training purposes. Whenever engine failure is to be simulated, it should be done by reducing power.*

**CAUTION...***A few minutes exposure to temperatures and airspeed at flight altitudes can have the same effect on an inoperative engine as hours of cold-soak in sub-Arctic conditions. If the engine must be restarted, consideration should be given to descending to warmer air. Closely monitor for excessive oil pressure as the propeller is unfeathered. Allow the engine to warm up at minimum governing RPM and 15 inches of manifold pressure.*

**15-05-08 ENGINE FIRE IN-FLIGHT (Refer to Airframe Manufacturer's Instructions)**

1. Fuel Selector - Turn to the Off Position.
2. Mixture Control - Place in the Idle Cut-Off Position.
3. Throttle Control - Place in the Closed Position.
4. Propeller Control
  - a. Non-Feathering Type Propeller - Full Decrease RPM Position.
  - b. Feathering Type Propeller - Feather Position.
5. Magneto Switch - Place Both in the "OFF" position.
6. Follow airframe manufacturer's instructions for emergency/forced landing.

INTENTIONALLY

LEFT

BLANK

## ABNORMAL ENVIRONMENTAL CONDITIONS

### 15-10-00 GENERAL

Three areas of operation require special attention, (a) extreme cold weather, (b) extreme hot weather and (c) high density altitude ground operation.

### 15-10-01 COLD WEATHER OPERATION (Ambient Temperature Below Freezing)

NOTE...Prior to operation and/or storage in cold weather assure engine oil viscosity is SAE 30, 10W30, 15W50 or 20W50. In the event of temporary cold weather operation, consideration should be given to hangaring the aircraft between flights.

Engine starting during extreme cold weather is generally more difficult than during normal temperature conditions. Cold soaking causes the oil to become thicker (more viscous), making it more difficult for the starter to crank the engine. This results in a slow cranking speed and an abnormal drain on the battery capacity. At low temperatures, gasoline does not vaporize readily, further complicating the starting procedure.

False starting (failure to continue running after starting) often results in the formation of moisture on spark plugs due to condensation. This moisture can freeze and must be eliminated either by applying heat to the engine or removing and cleaning the spark plugs.

### 15-10-02 PREHEATING

The use of preheat and auxiliary power unit (APU) is required to facilitate starting during cold weather and is required when the engine has been cold soaked at temperatures of 25°F, and below in excess of 2 hours.

The following procedures are required for preheating, starting, warm-up, run-up and takeoff.

1. Select a high volume hot air heater. Small electric heaters which are inserted into the cowling opening do not appreciably warm the oil and may result in superficial preheating.

**WARNING...Superficial application of preheat to a cold-soaked engine can cause damage to the engine.**

A minimum of preheat application may warm the engine enough to permit starting but will not de-congeal oil in the sump, lines, cooler, filter, etc.

**WARNING...Congealed oil may require considerable preheat. The engine may start and apparently run satisfactorily, but can be damaged from lack of lubrication due to congealed oil in various parts of the system. The amount of damage will vary and may not become evident for many hours. On the other hand, the engine may be severely damaged and could fall shortly following application of high power.**

Proper procedures require thorough application of preheat to all parts of the engine. Hot air must be applied directly to the oil sump and external oil lines as well as the cylinders, air intake and oil cooler. Excessively hot air can damage non-metallic components such as seals, hoses and drive belts, so do not attempt to hasten the preheat process.

**WARNING...Ensure that magneto switch is off and mixture is in idle cut-off.**

Before starting is attempted, turn the engine by hand or starter until it rotates freely. After starting, observe carefully for high or low oil pressure and continue the warm-up until the engine operates smoothly and all controls can be moved freely. Do not close the cowl flaps to facilitate warm-up as hot spots may develop and damage ignition wiring and other components.

2. Apply hot air primarily to the oil sump and filter area. The oil drain plug door or panel may provide access to these areas. Continue to apply heat for 15 to 30 minutes and turn the propeller by hand through 6 or 8 revolutions at 5 or 10 minute intervals.

**WARNING...To prevent possibility of serious bodily injury or death, before moving the propeller accomplish the following:**

- a. Verify magneto switches are "OFF".
  - b. Throttle position "CLOSED".
  - c. Mixture control "IDLE-CUT-OFF".
  - d. Set brakes and block aircraft wheels.
  - e. Assure that aircraft tie-downs are installed and verify that the cabin door latch is open.
  - f. Do not stand within the arc of the propeller blades while turning the propeller.
3. Periodically feel the top of the engine and when some warmth is noted apply heat directly to the upper portion of the engine for approximately five minutes. This will provide sufficient heating of the cylinders and fuel lines to promote better vaporization for starting. Occasionally transfer the source of heat from the sump to the upper part of the engine.
  4. Start the engine immediately after completion of the preheating process. Since the engine will be warm, use normal starting procedure.

**NOTE...Since the oil in the oil pressure gage line may be congealed, as much as 30 seconds may elapse before oil pressure is indicated. If oil pressure is not indicated within one minute, shut the engine down and determine the cause.**

5. Operate the engine at 1000 RPM or less until an increase in oil temperature is indicated before increasing RPM. Monitor oil pressure closely during this time and be alert for a sudden increase or decrease. Retard throttle, if necessary to maintain oil pressure below 100 psi. If oil pressure drops suddenly to less than 30 psi, shut down the engine and inspect the lubrication system. If no damage or leaks are noted, preheat the engine for an additional 10 to 15 minutes before restarting.



6. Before takeoff, run up the engine to 1700 RPM. If necessary approach this RPM in increments to prevent oil pressure from exceeding 100 psi.

At 1700 RPM, adjust the propeller control to Full Decrease RPM until minimum governing RPM is observed, then return the control to Full Increase RPM. Repeat this procedure three or four times to circulate warm oil into the propeller dome. If the airframe manufacturer recommends checking the propeller feathering system, move the control to the Feather position but do not allow the RPM to drop more than 300 RPM below minimum governing speed.

NOTE...Continually monitor oil pressure during run up.

7. Check magnetos in the normal manner.
8. When the oil temperature has reached 100°F and oil pressure does not exceed 70 psi at 2500 RPM, the engine has been warmed sufficiently to accept full rated power.

*CAUTION...Do not close the cowl flaps in a attempt to hasten engine warm-up.*

NOTE...Fuel flow will probably be on the high limit. However, this is normal and desirable since the engine will be developing more horsepower at substandard ambient temperatures.

### 15-10-03 HOT WEATHER OPERATION (Ambient Temperature in Excess of 90°F)

*CAUTION...When operating in hot weather areas, be alert for higher than normal levels of dust, dirt, or sand in the air. Inspect air filters frequently and be prepared to clean or replace them if necessary. Weather conditions can lift damaging levels of dust and sand high above the ground. If the aircraft is flown through such conditions, an oil change is recommended as soon as possible. Do not intentionally operate the engine in dust and/or sand storms. The use of dust covers on the cowling will afford additional protection for a parked aircraft.*

Flight operation during hot weather usually presents no problem since ambient temperatures at flight altitudes are seldom high enough to overcome the cooling system used in modern aircraft design. There are, however, three areas of hot weather operation which will require special attention on the part of the operator. These are: (1) starting a hot engine (2) ground operation under high ambient temperature conditions and (3) takeoff and initial climbout.

1. **Starting A Hot Engine.** After an engine is shutdown, the temperature of its various components will begin to stabilize. The hotter parts such as cylinders and oil will cool, while other parts will begin to heat up due to lack of air flow, heat conduction, and heat radiation from those parts of the engine which are cooling. At some point following engine shutdown the entire unit will stabilize near the ambient temperature. The time period will be determined by temperature and wind conditions and may be as much as several hours. Heat soaking is generally at the extreme from 30 minutes to one hour following shutdown. During this time, the fuel system will heat up causing the fuel in the pump and lines to "boil" or vaporize. During subsequent starting attempts the fuel pump will initially be pumping some combination of fuel and fuel vapor. At the same time, the injection nozzle lines will be filled with varying amounts of fuel and vapor. Until the entire fuel system becomes filled with liquid fuel, difficult starting and unstable engine operation can normally be expected.

Another variable affecting the fuel vapor conditions is the state of the fuel itself. Fresh fuel contains a concentration of volatile ingredients. The higher this concentration the more readily the fuel will vaporize and the more severe will be the problems associated with vapor in the fuel system. Time, heat or exposure to altitude will "age" aviation gasoline as these volatile ingredients tend to dissipate. This reduces the tendency of fuel to vaporize. Starting problems may occur if the volatility is not sufficient for adequate fuel vaporization.

The operator, by being cognizant of these conditions, can take certain steps to cope with problems associated with hot weather/hot engine starting. The primary objective should be that of permitting the system to cool. Reducing ground operation to a minimum is desired to keep engine temperatures down. Cowling flaps should be opened fully while taxiing. The aircraft should be parked so as to face into the wind to take advantage of the cooling effect. Restarting attempts will be the most difficult from 30 minutes to one hour after shutdown. Following that interval fuel vapor will be less pronounced and normally will present less of a restart problem.

2. **Ground Operation In High Ambient Temperature Conditions.** Oil and cylinder temperatures should be monitored closely during taxiing and engine run up. Operate with cowling flaps full open. Do not operate the engine at high RPM except for necessary operational checks. If takeoff is not to be made immediately following engine run up, the aircraft should be faced into the wind with the engine idling at 900-1000 RPM. It may be desirable to operate the fuel boost pumps to assist in suppressing fuel vaporization and provide more stable fuel pressure during taxiing and engine run up. Refer to aircraft Pilot's Operating Handbook concerning operation of boost pump.
3. **Take-off And Initial Climbout.** Do not operate at maximum power any longer than necessary to establish the climb configuration recommended by the aircraft manufacturer. Temperatures should be closely monitored and sufficient airspeed maintained to provide cooling of the engine.

*CAUTION...Reduced engine power will result from higher density altitude associated with high temperature.*

#### 15-10-04 GROUND OPERATION AT HIGH ALTITUDE AIRPORTS

Idle fuel mixture may be rich at high altitudes. Under extreme conditions, it may be necessary to manually lean the mixture in order to sustain engine operation at low RPM. When practical, operate the engines at higher idling speed.

- If higher than desired temperatures are experienced during the climb phase the pilot may elect to establish a lower angle of attack, or higher climb speed, consistent with safety and thereby provide increased cooling for engine.

**15-15-01 OPERATING DATA**

**Crankshaft Speed - RPM**

|  |      |
|--|------|
| Rated Maximum Continuous Operation . . . . .                       | 2700 |
| Rated Maximum Take-Off (IO-520-B,BA,BB,C,CB,M,MB) . . . . .        | 2700 |
| Recommended Max. for Cruising (IO-520-B,BA,BB,C,CB,M,MB) . . . . . | 2500 |

**Intake Manifold Pressure (In. Hg.)**

|  |                        |
|--|------------------------|
| Maximum Take-Off . . . . .                         | Full Throttle          |
| Maximum Continuous . . . . .                       | 28.8                   |
| Recommended Continuous Max. for Cruising . . . . . | See Performance Charts |

Fuel Control System . . . . . TCM Continuous Flow Injection

Fuel-Avia. Gasoline-Min Grade . . . . . 100LL (Blue) or 100 (Green)

Oil Specification . . . . . (Refer to Chapter 12 for Spec. MHS24F)

|  |                  |
|--|------------------|
| All Temperatures . . . . .               | 15W-30<br>20W-50 |
| Below 40°F Ambient (Sea Level) . . . . . | SAE 30 or 10W-50 |
| Above 40°F Ambient (Sea Level) . . . . . | SAE 50           |

**Oil Pressure**

|                                 |          |
|---------------------------------|----------|
| Idle, Minimum psi . . . . .     | 10       |
| Normal Operation, psi . . . . . | 30 to 60 |

**Oil Sump Capacity (U.S. Qts.)**

|                                   |    |
|-----------------------------------|----|
| IO-520B,BA,BB,C,CB,M,MB . . . . . | 12 |
|-----------------------------------|----|

Oil Level . . . . . \*

Oil Consumption (Lb/BHP/Hr. @ Max. rated power and RPM) . . . . .  $.006 \times \frac{\% \text{ POWER}}{100}$

**Oil Temperature Limits**

|                                |       |
|--------------------------------|-------|
| Minimum for Take-Off . . . . . | 75°F  |
| Maximum Allowable . . . . .    | 240°F |
| Recommended Cruising . . . . . | 170°F |

**Ignition Timing (Compression stroke, breaker opens)**

|                                      |     |
|--------------------------------------|-----|
| Right Magneto, degrees BTC . . . . . | 22° |
| Left magneto, degrees BTC . . . . .  | 22° |

**Cylinder Head Temperature\*\***

|                          |       |
|--------------------------|-------|
| Max. Cruise . . . . .    | 380°F |
| Max. Allowable . . . . . | 460°F |

\* Oil level is indicated by "calibration" marks on dip stick.  
 \*\*Bayonet thermocouple AS234 with AS236 adapter.

The curves in this chapter represent uninstalled performance and are provided as a reference in establishing power conditions for takeoff, climb and cruise operation. Refer to airframe manufacturer's flight manual for tabular climb and cruise data.

#### 15-15-02 CRUISE CONTROL BY PERFORMANCE CURVE

1. Set manifold pressure and RPM at cruise power selected.
2. To determine actual horsepower, employ the following procedure:
  - a. Correct horsepower for inlet air temperature as follows:

(TS) = Standard Altitude Temperature  
(1) Add 1% for each 10°F below TS.  
(2) Subtract 1% for each 10° F above TS
3. Adjust the mixture control to lean out fuel flow for cruise settings according to applicable fuel flow vs. brake horsepower curve.

*CAUTION...When increasing power, enrich mixture, advance RPM and adjust throttle in that order. When reducing power, retard throttle. Then, adjust RPM and mixture.*

*NOTE...It may be necessary to make minor readjustments to fuel flow (mixture) after changing RPM.*

#### 15-15-03 CRUISE CONTROL BY EGT

If exhaust gas temperature indicator is used as an aid to leaning proceed as follows:

1. Adjust RPM and manifold pressure for desired cruise setting.
2. Slowly move mixture control toward "lean" while observing EGT gage. Note position on the instrument where the needle "peaks" or starts to drop as mixture is leaned further.
3. At cruise settings between 65% and 75% advance mixture control toward "rich" until EGT is 25°F. colder than peak. At cruise setting below 65% engine may be operated at peak EGT.

*CAUTION...Do not attempt to adjust mixture by use of EGT at setting above 75% of maximum power. Also, remember that engine power will change with ambient conditions. Changes in altitude or outside air temperature will require adjustments in manifold pressure and fuel flow. (Refer to Charts Fuel Flow Vs. BHP).*

Gage fuel flow should fall between the maximum and minimum values on the curve. If not, the fuel injection system or instrumentation (including tachometer, manifold pressure, fuel flow gage or EGT system) should be checked for maladjustments or calibration error.

## FIGURE INDEX

| Figure No.      |   | Page     |
|-----------------|---|----------|
| Figure 15-15-01 | Fuel Flow Vs. BHP for IO-520-B,BA & BB . . . . .            | 15-15-05 |
| Figure 15-15-02 | Sea Level Performance Curves for IO-520-B,BA & BB . . . . . | 15-15-06 |
| Figure 15-15-03 | Altitude Performance Curves for IO-520-B,BA & BB . . . . .  | 15-15-07 |
| Figure 15-15-04 | Fuel Flow Vs. BHP for IO-520-C & CB . . . . .               | 15-15-08 |
| Figure 15-15-05 | Sea Level Performance Curves for IO-520-C & CB . . . . .    | 15-15-09 |
| Figure 15-15-06 | Altitude Performance Curves for IO-520-C & CB . . . . .     | 15-15-10 |
| Figure 15-15-07 | Fuel Flow Vs. BHP for IO-520-M & MB . . . . .               | 15-15-11 |
| Figure 15-15-08 | Sea Level Performance Curves for IO-520-M & MB . . . . .    | 15-15-12 |
| Figure 15-15-09 | Altitude Performance Curves for IO-520-M & MB . . . . .     | 15-15-13 |

INTENTIONALLY

LEFT

BLANK

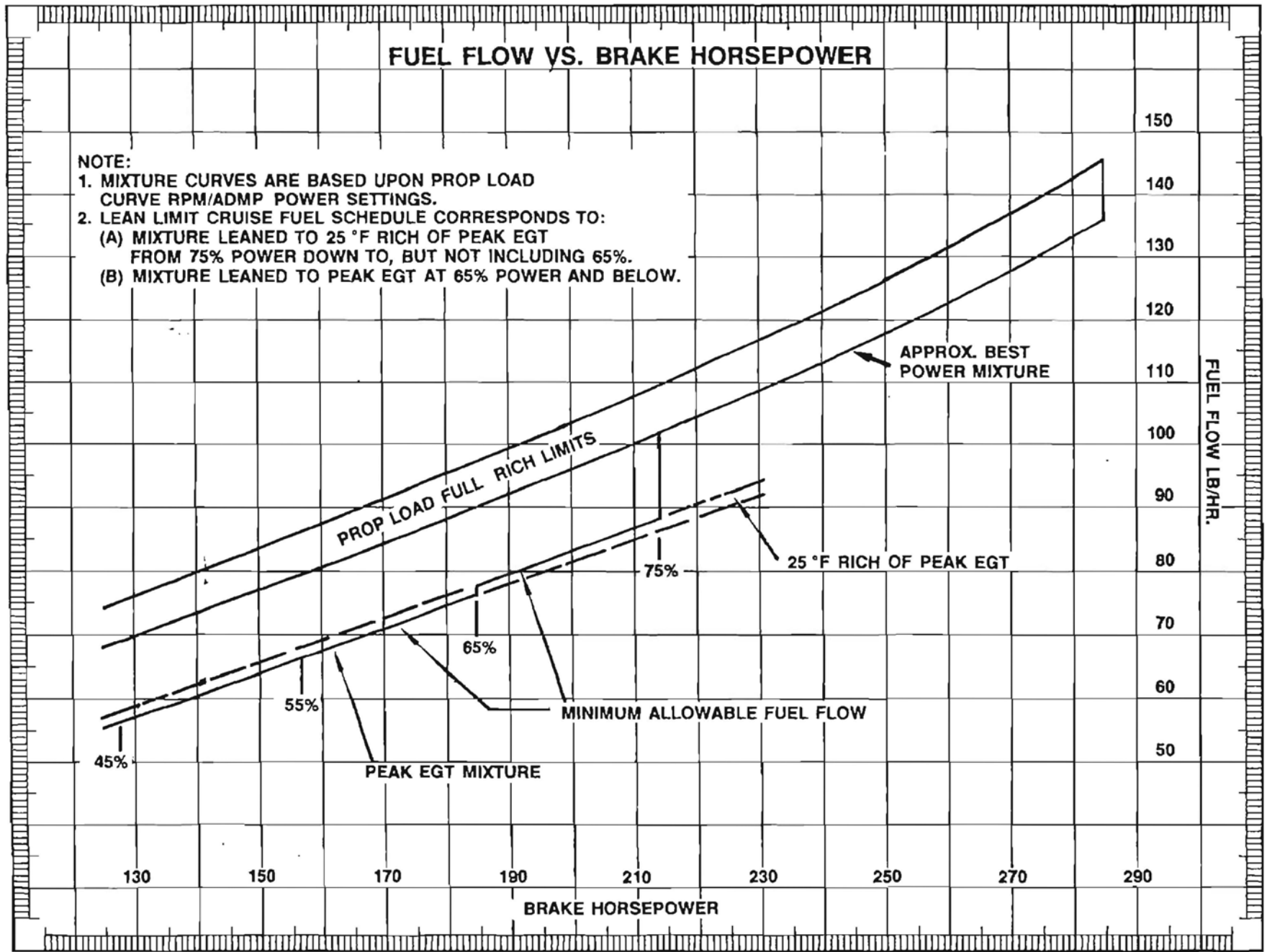

Figure 15-15-01. Fuel Flow Vs. BHP for IO-520-B,BA & BB

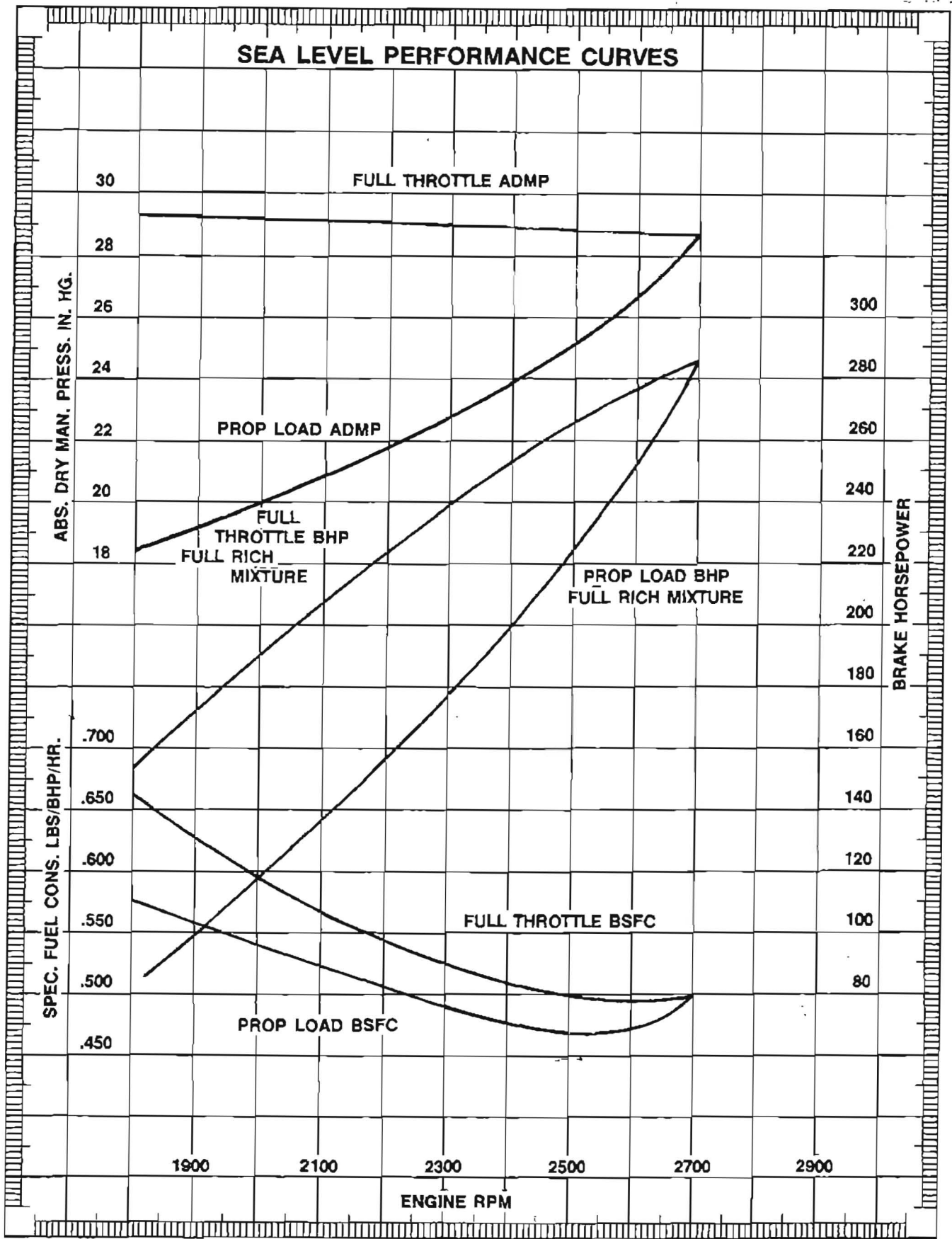

Figure 15-15-02. Sea Level Performance Curves for IO-520-B,BA & BB



Figure 15-15-03. Altitude Performance Curves for IO-520-B, BA & BB

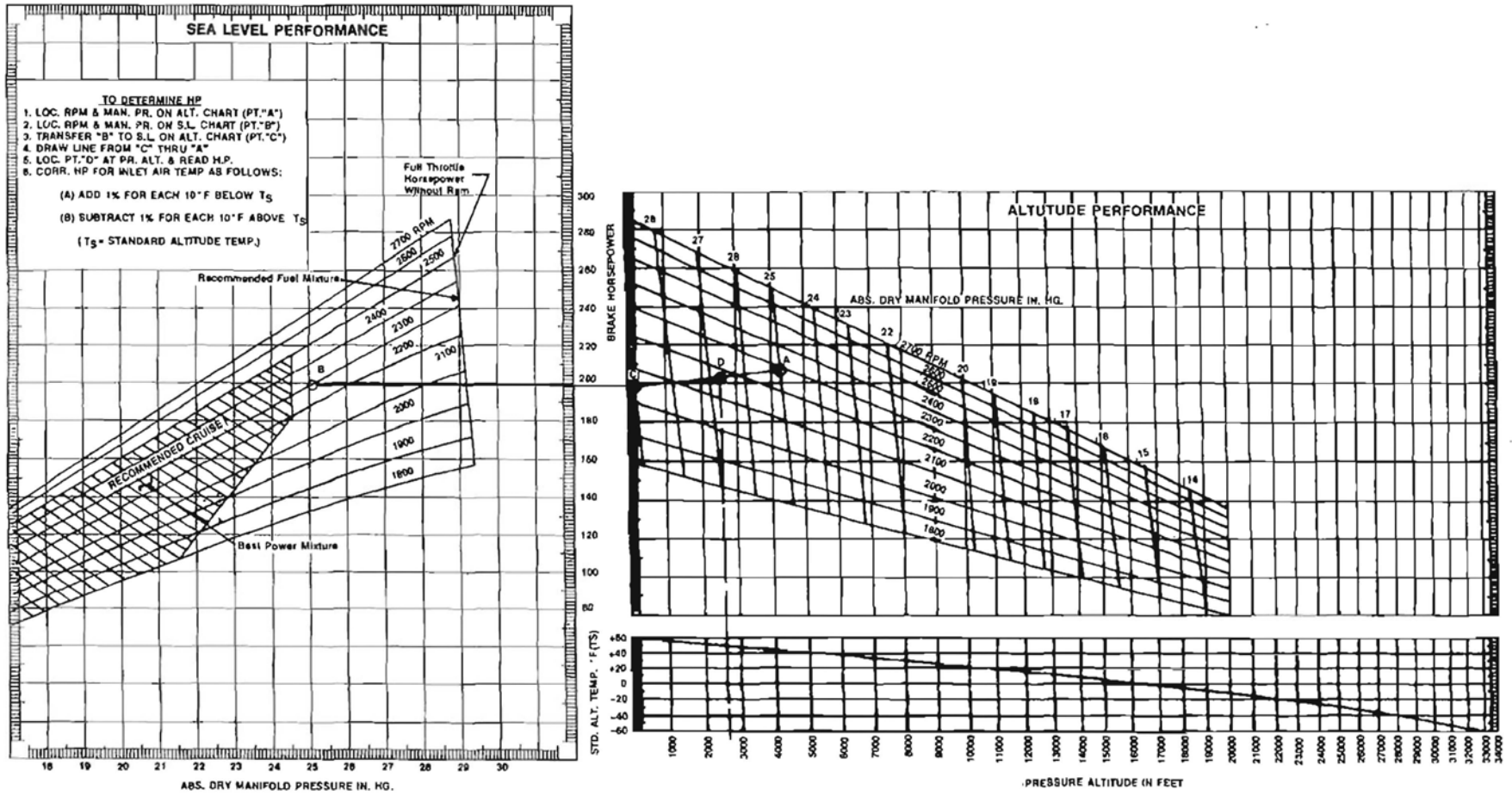
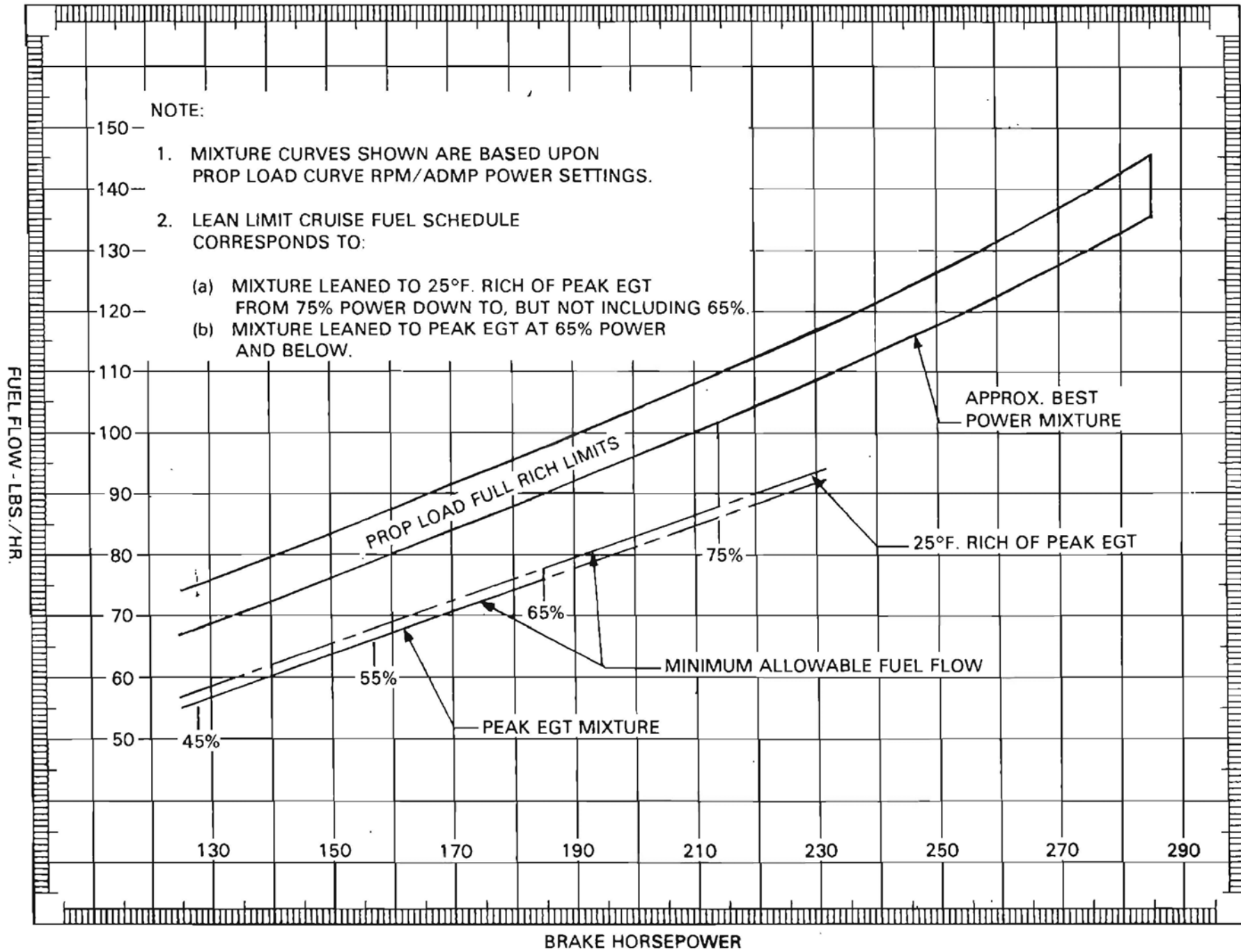

Figure 15-15-04 Fuel Flow Vs. BHP for IO-520-C & CB



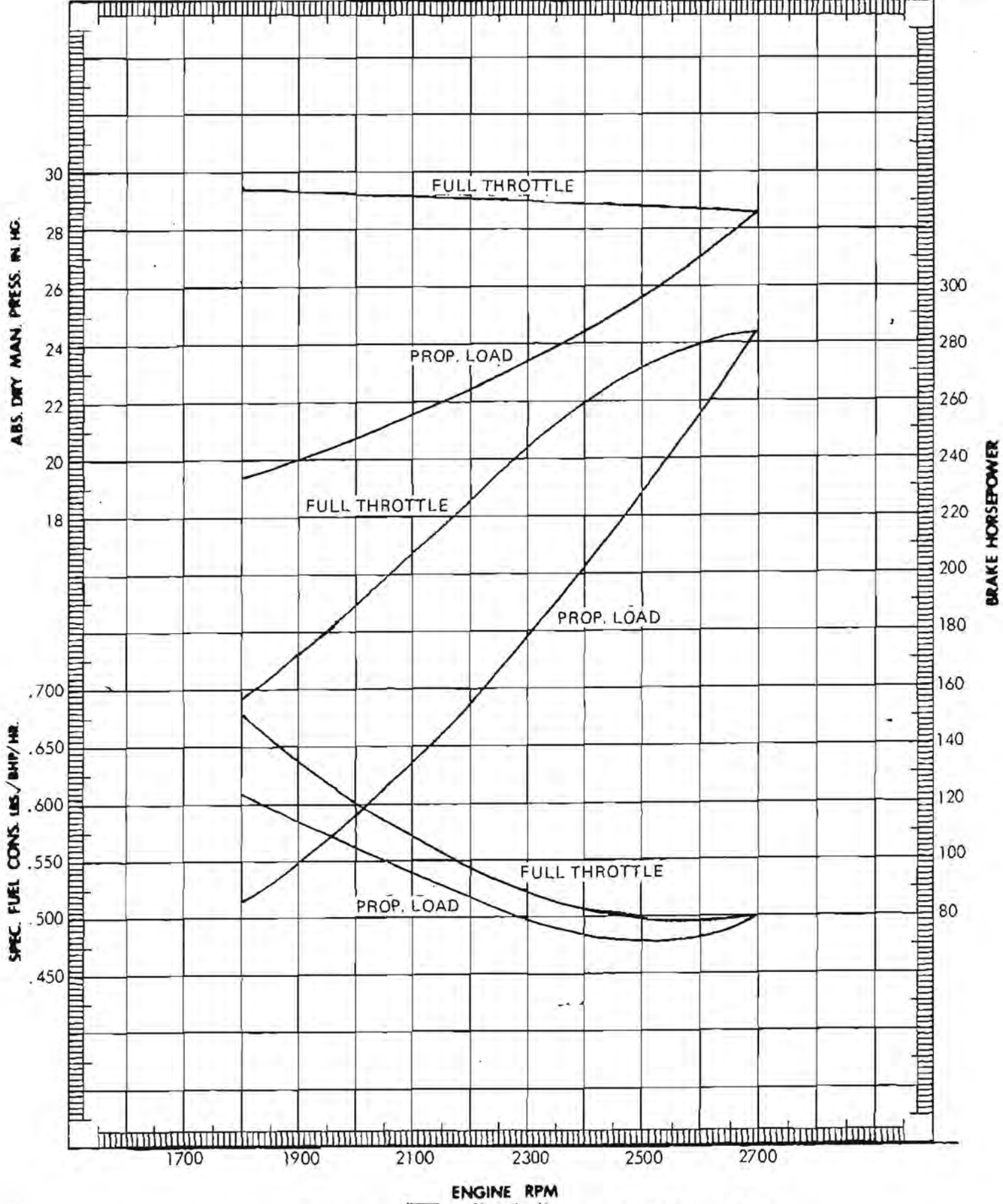
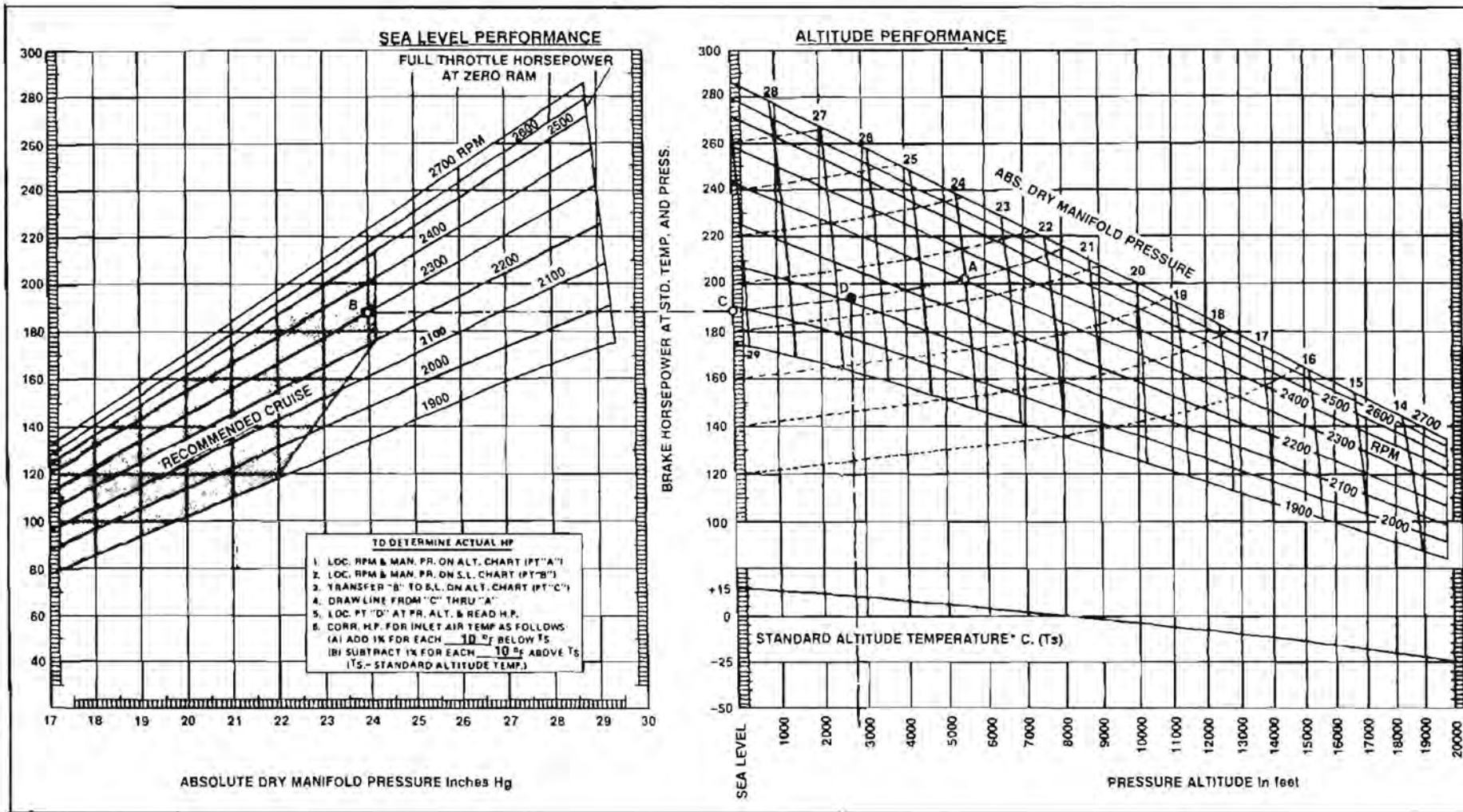

Figure 15-15-05 Sea Level Performance Curves for IO-520-C & CB

Figure 15-15-06 Altitude Performance Curves for IO-520-C & CB



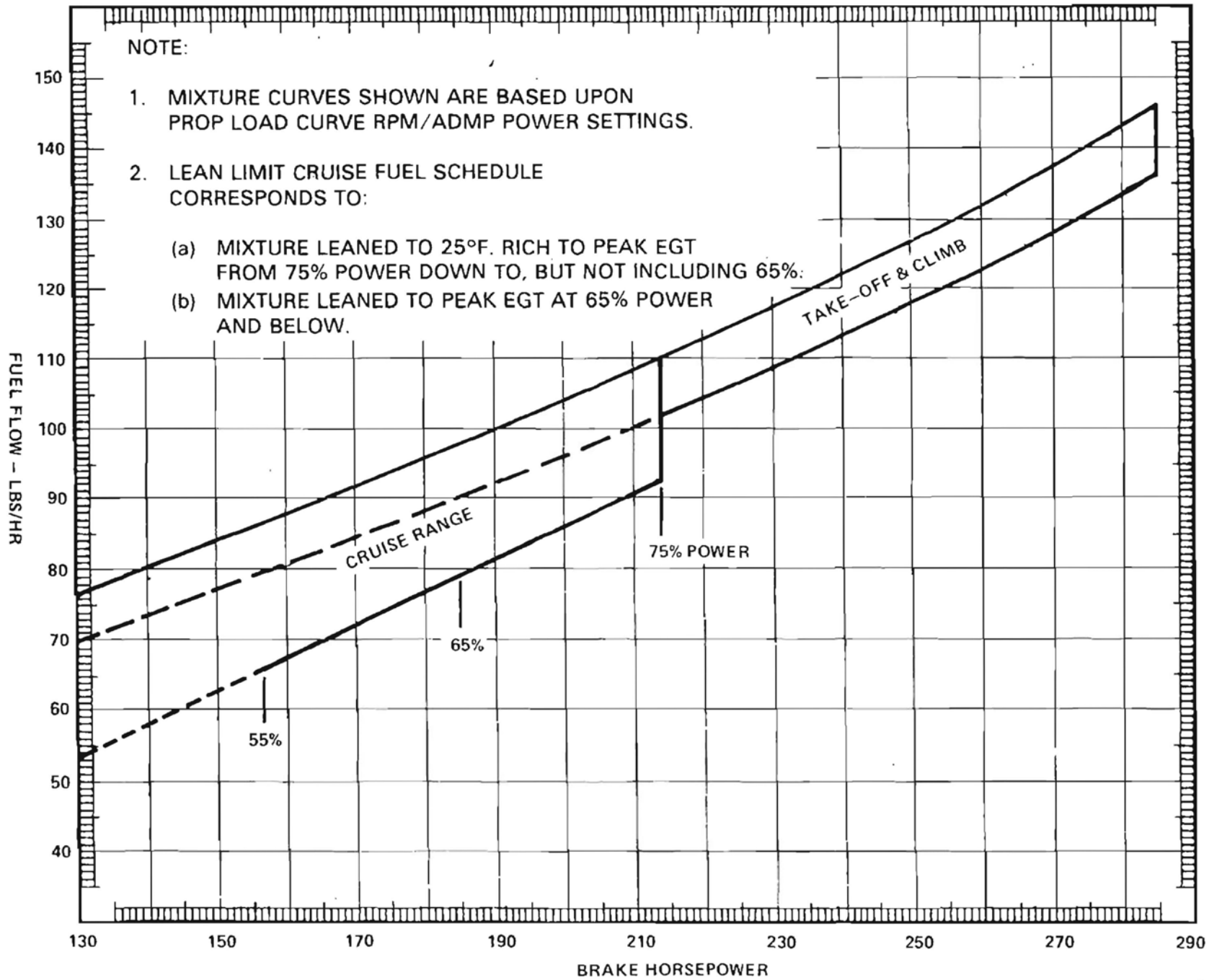

Figure 15-15-07. Fuel Flow Vs. BHP for IO-520-M & MB

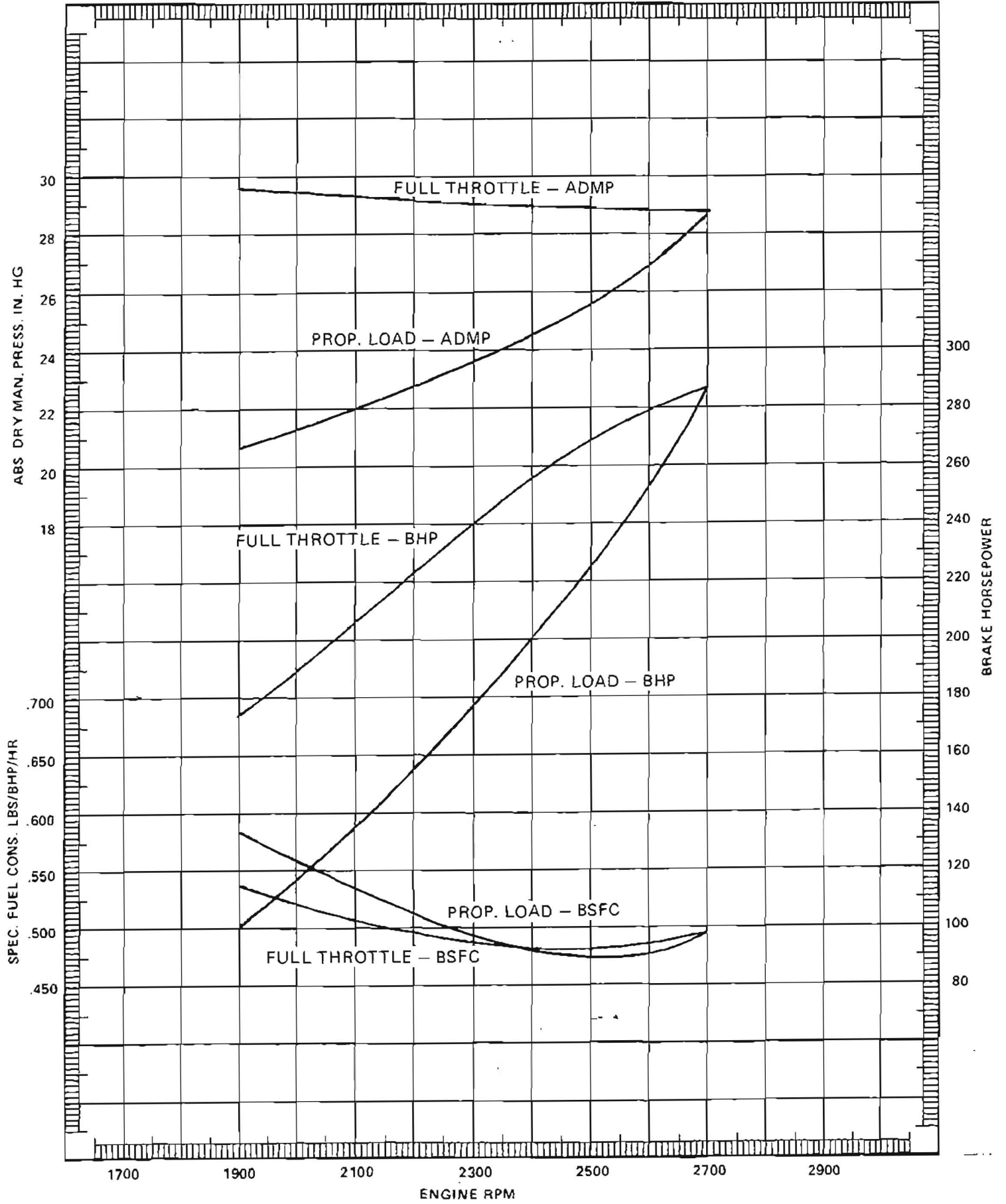
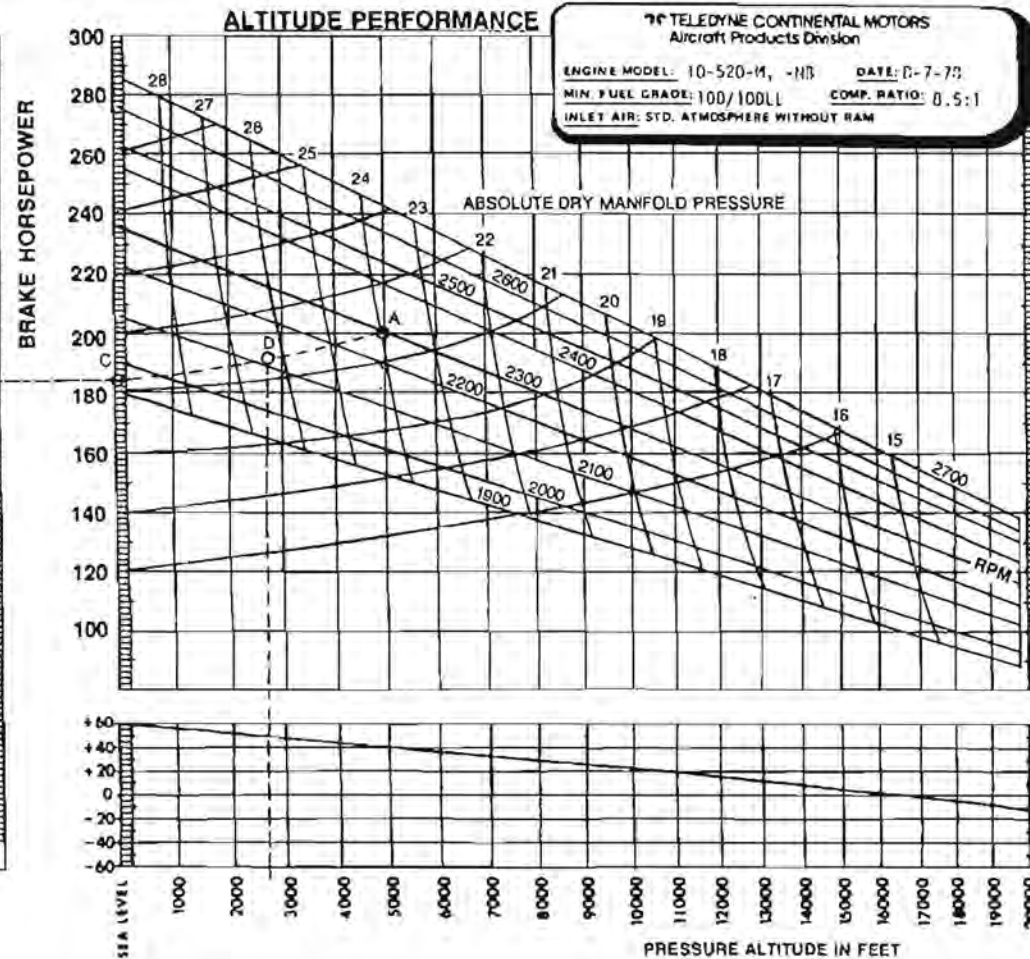
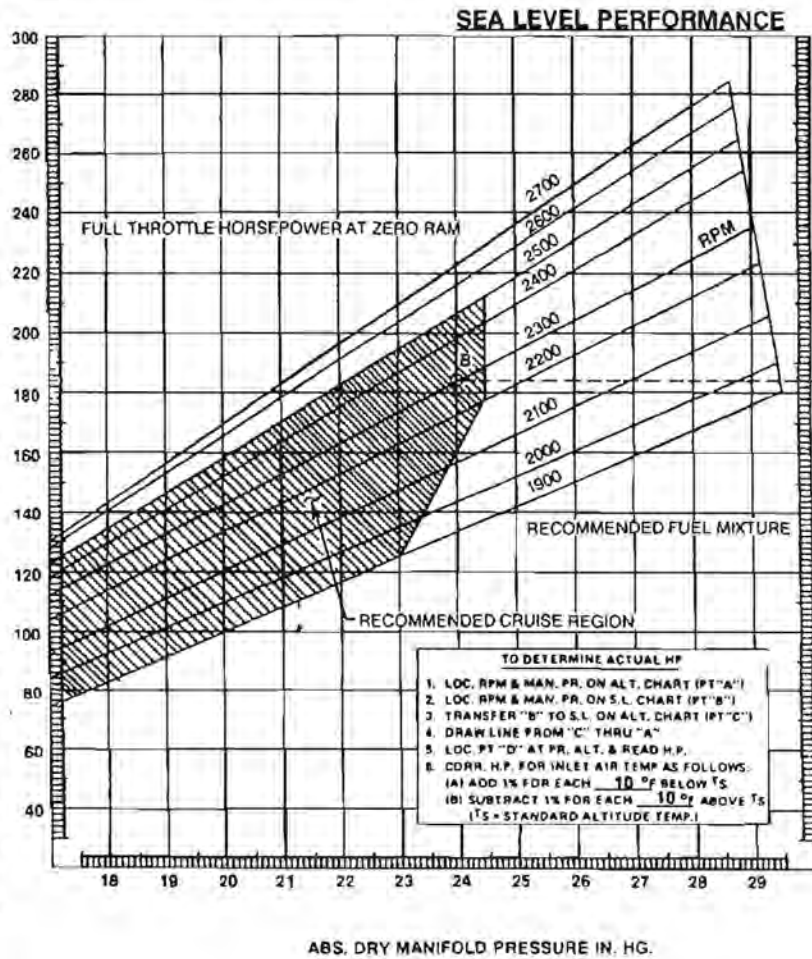

Figure 15-15-08. Sea Level performance Curves for IO-520-M & MB

Figure 15-15-09. Altitude Performance Curves for IO-520-M & MB



INTENTIONALLY

LEFT

BLANK



## **CHAPTER 70 STANDARD PRACTICES**

Refer to the IO-520 Permold Series Maintenance Manual Form X30626A Chapter 70. See section 1-00-02 Related Publications for ordering information.

INTENTIONALLY

LEFT

BLANK

## **CHAPTER 72 ENGINE RECIPROCATING**

Refer to the IO-520 Permold Series Maintenance Manual Form X30626A or Overhaul Manual Form X30627A Chapter 72. See section 1-00-02 related publications for ordering information.

INTENTIONALLY

LEFT

BLANK





**Continental Motors, Inc.**  
**[www.continentalmotors.aero](http://www.continentalmotors.aero)**