

IGNITION SWITCHES STARTER SWITCHES AND DOOR LOCK KITS

CONTINENTAL[®] IGNITION SYSTEMS

SERVICE SUPPORT MANUAL



Publication X43002-1

©2011 CONTINENTAL MOTORS, INC.

AUG 2011

Intentionally Left Blank

WARNING

(Please note the following statements from FAA Advisory Circular 20-62C entitled "ELIGIBILITY, QUALITY, AND IDENTIFICATION OF APPROVED REPLACEMENT PARTS"):

3. **BACKGROUND.** An increasing amount of replacement parts (including standard parts), materials, appliances, and instruments are offered for sale as being of aircraft quality when actually the quality and origin of these units are unknown. Users of such units are usually not aware of the potential hazards involved with replacement parts that are **not** eligible for use on certificated aircraft. Frequently such units are deceptively advertised or presented as "**unused**," "**like new**," or "**remanufactured**." This implies that the quality of such units is equal to an original or appropriately repaired or overhauled unit.

The performance rules for replacement of parts and materials used in the maintenance and alteration of U.S. certificated aircraft are specified in Federal Aviation Regulations (FAR) 43.13 and FAR 145.57. The responsibility for the continued airworthiness of the aircraft, which includes the replacement of parts, is the responsibility of the owner/operator as outlined in FAR 91.163, FAR 121.363, FAR 123.45, FAR 127.131 and FAR 135.143 (a).

4. **IDENTIFICATION OF THE APPROVED PARTS.** Approved serviceable replacement parts are identified as follows:

- a. By an FAA Form 8130-3 (Formerly FAA Form 186), Airworthiness Approval Tag. An Airworthiness Approval Tag identifies a part or group of parts that have been approved by authorized FAA representatives.
- b. By an FAA Technical Standard Order (TSO) number and identification mark that indicates the part or appliance has been manufactured under the requirements of FAR 37.
- c. By an FAA/PMA symbol, together with the manufacturer's name, trademark or symbol, part number, and the make and model of the type certificated product on which the part is eligible for installation, stamped on the part. An FAA Parts Manufacturer Approval (FAA/PMA) is issued under FAR 21.305. The make and model information may be on a tag attached to the part.
- d. By shipping ticket, invoice, or other document which provides evidence that the part was produced by a manufacturer holding an FAA Approved Production Inspection System issued under FAR 21, Subpart F, or by a manufacturer holding an FAA Production Certificate issued under FAR 21, Subpart G.
- e. By a certificate of airworthiness for export issued by a foreign government under the provisions of FAR 21, Subpart N.

11. **KNOW YOUR SUPPLIER.** It has come to our attention that many reproduced parts and components, particularly instruments which have been manufactured by persons other than the original manufacturer, are available for purchase and installation on U.S. certificated aircraft. Often, an original part is used as a sample to produce duplicates. The reproduced parts appear to be as good as the original part; however, there are many unknown factors to be considered that may not be readily apparent to the purchaser, i.e., heat treating, plating, inspections, tests and calibrations. All too often the faulty part is not discovered until a malfunction or an accident occurs.

12. **SUMMARY.** In accordance with FAR's, certification of materials, parts, and appliances for return to service, for use on aircraft, is the responsibility of the person or agency who signs the approval. The owner/operator, as denoted in paragraph 3 of this advisory circular, is responsible for the continued airworthiness of the aircraft. To assure continued safety in aircraft operation, it is essential that great care be used when inspecting, testing, and determining the acceptability of all parts and materials. Particular caution should be exercised when the identity of materials, parts, and appliances cannot be established or when their origin is in doubt.

System Support Manual

IGNITION/STARTER SWITCHES AND DOOR LOCK KITS

TABLE OF CONTENTS

WARNING	ii
INTRODUCTION	iv
DESCRIPTION AND OPERATION	v
DISASSEMBLY	1
Disassemble Ignition/Starter Switches	1
Disassemble Type GM Switches	1
Disassemble Door Locks	1
CLEANING AND INSPECTION	1
ASSEMBLY	2
Assemble Ignition/Starter Switches	2
Assemble GM Type Switches	2
TESTING	3
Testing Ignition/Starter Switches	3
Testing GM Type Switches	3
Testing Door Locks	3
INSTALLATION	4
ILLUSTRATED PARTS LIST	5
Equipment Covered	5
Ignition Switches	6
Switch and Door Lock Kits	8
Numerical Parts List	10
Superseded and Discontinued Items	11

Ignition Switch Leading Particulars

Contacts	Rated to handle magneto primary voltage and/or 24 volts DC, 5 amps
Insulation Test	1,000 volts DC to ground. Use 11-8950-2 High Tension Lead Tester Kit.
Lever Type Switch	Has removable lever to facilitate mounting
Key Type Switch	Has disc tumbler lock with removable key. Available with matching door locks.
Corrosion Resistance	50 hr salt test per Fed. Spec. QQ-M-151-A
Lubrication	Cramolin Paste Type 20Kd
Mounting	Adjustable for panel thickness to .312 in.
Position Indicating Dial	Available as desired
Weight	7 oz.
Housing	Die cast

System Support Manual

IGNITION/STARTER SWITCHES AND DOOR LOCK KITS

INTRODUCTION

GENERAL

- A. This manual provides complete maintenance instructions with illustrated parts list for Ignition/Starter Switches and Door Lock Kits, manufactured by Teledyne Continental Motors, Aircraft Products, Mobile, Alabama 36601. TCM Ignition Switches control magneto operation. Many switches also include controls for starting and electric primer circuits. Door locks are used to secure cabin doors and/or baggage compartment doors. Switch and door lock kits incorporate matching lock mechanisms and are operated by a single key for maximum convenience.
- B. This manual is subdivided with sub-heads as listed in the Table of Contents. Revision service may be provided by ordering Master Service Manual Form X40000. TCM Ignition Systems Service Bulletins included in Master Service Manual provide current information related to service, maintenance and technical support of the product. Service Bulletins 583 and 615 have been incorporated into this manual. This manual may be included in Chapter 74-30 of applicable GAMA format publications.
- C. These instructions do not cover all details or variations in equipment nor do they provide for every possible contingency to be met in connection with installation, operation, or maintenance. Should further information be desired or particular problems arise which are not covered sufficiently for purchaser's purpose, contact

**Table 1
Abbreviations**

US Standard Unit	Abbreviation
Degrees Fahrenheit	°F
Inch	in.
Pound Inches	lb in.
Pound Force	lbf
Pound (Mass)	
Pounds per Hour	pph
Pounds per Square Inch, Absolute	psia
Pounds per Square Inch Gage	psig
Feet	ft
Gallons	gal
Ounces	oz

your local TCM distributor or TCM field representative. Requests for copies of Teledyne Continental Aircraft Engine Service publications should be made through your distributor or Teledyne Continental Motors, P. O. Box 90, Mobile, AL 36601, Attn: Publications Department.

- D. Good standard shop practices and safety precautions should be observed at all times to avoid damage to equipment and or injury to personnel.
- E. All maintenance instructions in this manual have been shop verified. Shop verified procedures are those by which the manufacturer has accomplished all Disassembly, Assembly, Testing and Fault Isolation by performing the functions described in this manual on equipment identical in configuration to that described.
- F. Dimensions are given in Standard Units. For reference, abbreviations used are listed in Table 1.
- G. Numbers in parentheses following part nomenclature refer to item numbers in illustrated Parts List Figure 1 and 2 unless otherwise specified. Example: (1-5) is item 5 in IPL Figure 1; (2-1) is item 1 in IPL Figure 2.

Recommendations, cautions and warnings regarding maintenance of this equipment are not intended to impose undue restrictions. They are inserted to obtain maximum performance from the equipment in accordance with safety and efficiency. Abuse, misuse, or neglect of any piece of equipment can cause eventual failure. For an aircraft engine it is obvious that a failure may have disastrous consequences. Failure to observe the instructions contained in this manual constitutes unauthorized operation in areas unexplored during development of the engine, or in areas in which experience has proved to be undesirable or detrimental.

NOTES, CAUTIONS and WARNINGS are included throughout this manual. Application is as follows:

NOTE. . . Special interest information which may facilitate the operation of equipment.

CAUTION. . . Information issued to emphasize certain instructions or to prevent possible damage to engine or accessories.

WARNING. . . Information which, if disregarded, may result in severe damage to or destruction of the engine or endangerment to personnel.

System Support Manual

IGNITION/STARTER SWITCHES AND DOOR LOCK KITS

DESCRIPTION AND OPERATION

GENERAL

A. Ignition switches manufactured by Teledyne Continental Motors, Aircraft Products, Mobile, Alabama 36601 are designed to provide control of magneto operation. Optional starter solenoid control, electrical primer control, and key or lever designs are available as shown in Figure 1.

B. The various switch position functions are listed below*.

OFF Both magnetos inoperative

R Right magneto operating
Left magneto inoperative

L Left Magneto operating
Right magneto inoperative

BOTH Both magnetos operative

START Battery terminal connected to starter solenoid through start terminal. Right magneto may be grounded with jumper between right terminals. Left magneto main and retard contacts may be connected to starting vibrator output. Spring return to both position.

PUSHTOPRIME Allows aircraft to be electrically primed either in BOTH or START position. Spring loaded to normally open circuit position.

C. Typical ignition switch mounting dimensions are shown in Figure 2. Dimensions are in inches.

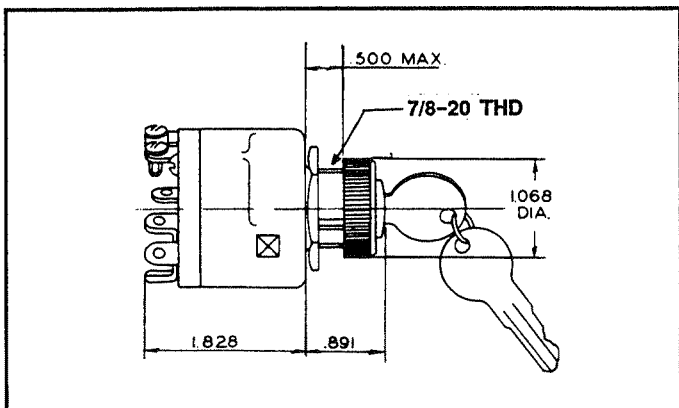

Figure 2. Switch Dimensions

Twist to Start

10-357200-1
with 2 Keys

10-357200-12
with 2 Cessna Keys

10-357230-1
Lever Type

10-357260-1
Lever Type, without
Lever

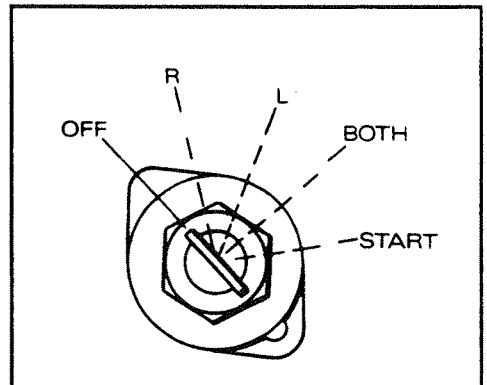

Push to Start

10-357210-1
with 2 Keys

10-357210-9
with 3 Keys

10-357240-1
Lever Type

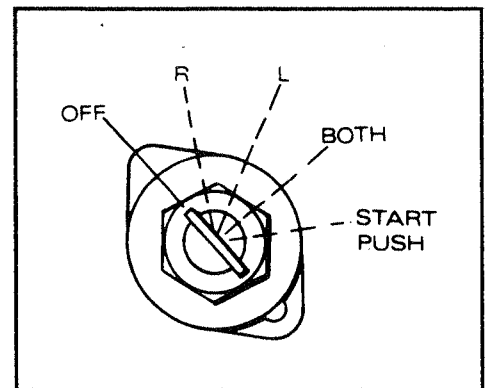

Twist to Start Push to Prime

10-357220-1
with 2 Keys

10-357250-1
Lever Type

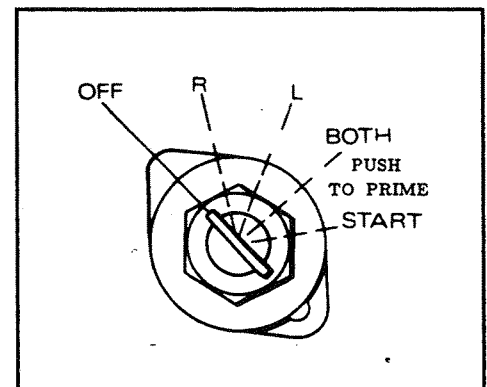

GM Type

10-357290-1
with 2 Keys

10-357290-13
with 2 Cessna Keys

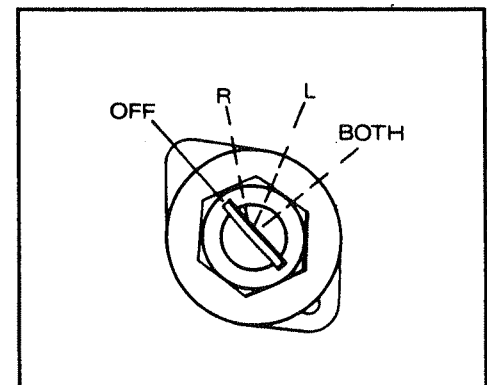

Figure 1. Switch Functions

System Support Manual

IGNITION/STARTER SWITCHES AND DOOR LOCK KITS

- D. Ignition switch placard indicator dials are available for each type of switch.
- E. Door locks are supplied in kits as listed in Illustrated Parts List. Door locks supplied with key-actuated switches are actuated by the same key. Door locks listed in Illustrated Parts List are also available separately and, when purchased this way, will have their own key. If a door lock or switch becomes damaged, a new one may be purchased separately.

MAINTENANCE RECOMMENDATIONS

- A. Ignition switch maintenance is conducted on an on-condition basis. Whenever access allows, components should be inspected for positive operation, wear, binding, looseness or burning. Replace components as necessary.
- B. For key operated switches, due to the danger of removing the key from the switch in other than the "OFF" position, switch locks (1-20) utilizing keys marked with PK number code listed in Table 2 marked as shown in Figure 3 should be removed and replaced at customer's earliest convenience. If key is not marked with PK number code, refer to outside face of any matching door locks.

Table 2

KEY PK NUMBER CODES
PK-502, 503, 504, 506, 507, 511, 512, 513, 523, 524, 525, 528, 530, 532, 533, 536, 537, 539, 544, 551, 553, 563, 565, 572, 573
PK-605, 606, 613, 616, 617, 618, 627, 639, 641, 642, 643, 646, 648, 650, 653, 657, 660, 667, 682
PK-722, 729, 731, 734, 735, 736, 738, 743, 744, 745, 755, 756, 758, 760, 763, 765, 766, 767, 773, 774, 777, 784, 786, 798
PK-800, 805, 807, 814, 846, 848, 850, 852, 853, 855, 860, 862, 869, 872, 873, 876, 880, 881, 882, 884, 887, 889, 890, 891, 894
PK-901, 914, 916, 921, 922, 923, 930, 956, 963, 966, 967, 968, 970, 971, 978, 985, 990, 992, 996, 997, 999

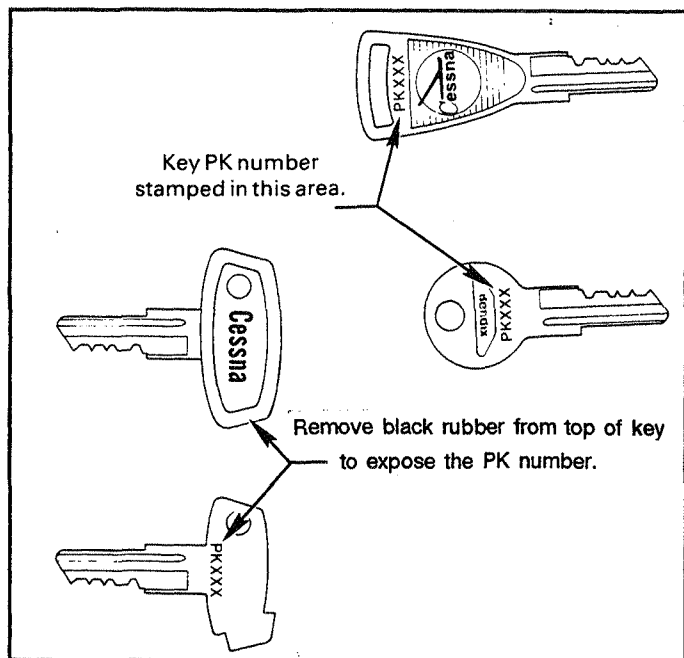

Figure 3. PK Number Location

- C. For all switches with start position, to ensure positive grounding of magnetos when in "OFF" position, old support (1-2) should be replaced with current design support (1-2) at customer's earliest convenience. Current design support includes oversize rivet head as shown in Figure 4. Current support (1-2) is identified with white paint mark on terminal lug side of support.

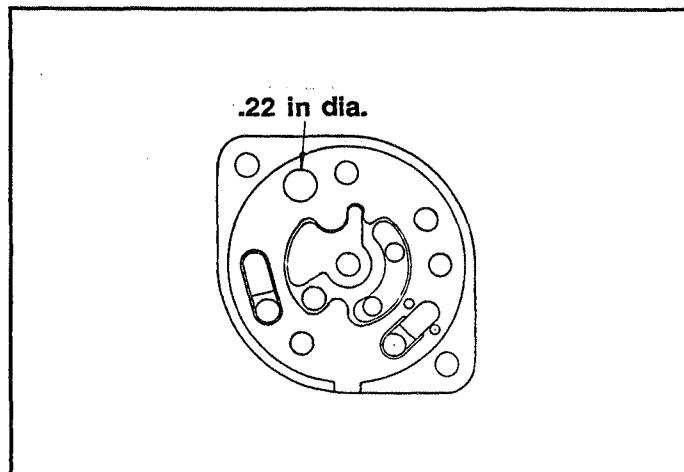

Figure 4. Current Support (1-2) Ignition/Starter Switches

System Support Manual

IGNITION/STARTER SWITCHES AND DOOR LOCK KITS

MAINTENANCE INSTRUCTIONS

DISASSEMBLY

NOTE:

Complete disassembly is not necessary in all instances. Only disassemble switch to the extent necessary for repairs.

A. Disassemble Ignition/Starter Switches:

- (1) On switches which incorporate a lever, remove lever (1-15) by removing screw (1-13) and lockwasher (1-14) from shaft (1-18). Remove nut (1-16 or 1-17) and dial (1-22) if used. Remove switch from panel and remove all wires from switch terminals. (On key actuated switches begin disassembly with removal of nut (1-16 or 1-17) and dial (1-22) if used.)
- (2) Remove self-tapping screws (1-1) and pull off support (1-2). Take out switch contacts (1-3) and spring (1-4). Remove self-tapping screw (1-1), lockwasher (1-5) and plain washer (1-6) from center of rotor (1-7).
- (3) Remove lock assembly (1-20) or shaft (1-18) from front of switch. Pull rotor (1-7) from housing (1-21). Lift spring (1-11) and retainer (1-12) from rotor (1-7).
- (4) The 10-357210 series switches incorporate a bushing (1-19) on end of lock assembly. Slide bushing from end of this assembly.
- (5) If used, pull pin (1-8) from rotor (1-7). Remove bracket (1-9) and spring (1-10, 1-10a).

B. Disassemble Type GM Switches (10-357290 Series):

- (1) Remove knurled nut (1-16) and dial (1-22) from switch. Remove switch from panel and disconnect wires from terminals by removing nuts (1-28) and lock washers (1-5a). Remove hex nut (1-17). Remove two screws (1-1) which secure switch contact support (1-2) to housing (1-21). Lift two contact brackets (1-9) and coil springs (1-10a) from switch rotor (1-7a). Remove screw (1-1), lock washer (1-5a) and flat washer (1-6a) which secure rotor (1-7a) to switch lock assembly (1-20). Switch lock assembly can now be removed from the housing.

C. Door Locks

Do not attempt disassembly of door locks.

CLEANING AND INSPECTION

- A. Clean all switch parts thoroughly with trichlorethylene or other suitable solvent.
- B. Inspect switch rotor (1-7) and contact support (1-2, 1-2a) for cracks and check contact surfaces for grooves or excessive wear. Inspect switch contact bracket (1-9) and switch contacts (1-3, 1-3a) for excessive wear, corrosion or deformation.
- C. Inspect lock assembly and key (1-20) for wear. When key is inserted, the brass tumblers should be flush with barrel. Small extensions may be filed off, or a new key may correct this condition.
- D. If positioning spring, which is in switch housing (1-21), is broken, has weak spring tension or shows signs of considerable wear, replace switch housing (1-21).

System Support Manual

IGNITION/STARTER SWITCHES AND DOOR LOCK KITS

ASSEMBLY

NOTE:

During assembly, sparingly apply Cramolin paste type 20Kd* to contact (1-3) face, to bracket (1-9) contact surfaces and to contact side of support (1-2, 1-2a) assemblies. A dab of this paste may also be applied to positioning spring in housing (1-21) and to lock (1-20) key teeth.

A. Assemble Ignition/Starter Switches

- (1) If used, assemble spring (1-10), bracket (1-9) and pin (1-8) into rotor (1-7).
- (2) Assemble radial tang of spring (1-11) into rotor (1-7) groove.
- (3) Assemble spring retainer (1-12) hole onto axial tang of spring (1-11) with boss on retainer (1-12) towards rotor (1-7). Wind retainer (1-12) counter-clockwise until retainer arm rests in recess in rotor (1-7).
- (4) Orient rotor (1-7) assembly so ridged portion aligns with positioning spring in housing (1-21). Refer to Figure 5. Seat rotor (1-7) completely into housing (1-21).
- (5) Assemble bushing (1-19) (if used), lock plug (1-20) or shaft (1-18) into housing (1-21) and rotor (1-7) assembly. Chamfered edges on lock plug (1-20) and shaft (1-18) allow parts to be assembled only one way. During assembly, support rotor (1-7) with fingers to prevent pushing it back out of housing (1-21). Assemble washer (1-6), lockwasher (1-5) and screw (1-1) into rotor (1-7) and lock plug (1-20) or shaft (1-18). Tighten and adjust screw (1-1) to allow no binding during switch operation and minimal end play. If this is not possible, replace lock plug (1-20) or shaft (1-18).
- (6) Insert springs (1-4) into recesses in rotor (1-7). Assemble contacts (1-3) onto springs (1-4). Align boss in support (1-2) with notch in housing (1-21) and assemble with two screws (1-1).
- (7) Test switch in accordance with Testing procedures.

B. Assemble GM Type Switches

- (1) Assemble contacts (1-3a, 1-3b), screws (1-25, 1-26), washers (1-27, 1-5a) and nuts (1-28) onto support (1-2a). Apply 8-11 lb. in. torque to each inner nut (1-28).
- (2) Align rotor (1-7a) in housing (1-21) as shown in Figure 5. Seat rotor (1-7a) completely into housing (1-21).
- (3) Insert lock plug (1-20) into rotor (1-7a) and assemble screw (1-1), lock washer (1-5a) and washer (1-6a) into rotor (1-7a) and lock plug

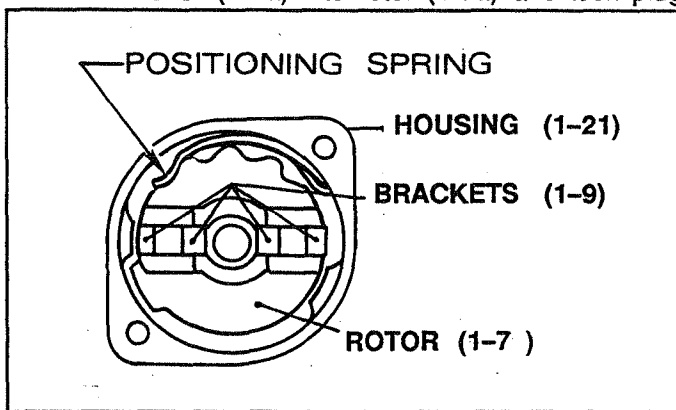

Figure 5. Proper Positioning of Rotor

- (1-20) tighten and adjust screw (1-1) to allow no binding during switch operation and minimal end play. If this is not possible, replace lock plug (1-20).
- (4) Assemble springs (1-10a) and brackets (1-9) into rotor (1-7a). Brackets (1-9) should slide freely into and out of rotor (1-7a) and should be aligned as shown in Figure 5.
- (5) Align boss on support (1-2a) with notch in housing (1-21) and assemble with two screws (1-1).
- (6) Test switch in accordance with Testing procedures.

*Cramolin Paste Type 20Kd available in 1 oz. can, Catalog No. P-200-K1, from Caig Laboratories, 1775-0 Industrial Ave. (P. O. Box J), Escondido, CA 92025-0051.

System Support Manual

IGNITION/STARTER SWITCHES AND DOOR LOCK KITS

TESTING

GENERAL:

Following assembly, test switch for positive operation. Action must be smooth, without sticking. Keys must be removable in only the "OFF" position. Test switch electrical operation as described in paragraph A and B below. If switch fails tests, check for incorrect assembly or bent switch contact brackets.

A. Testing Ignition/Starter Switch

- (1) Using the 11-8950-2 Tester or equivalent, check for continuity between each terminal and all other terminals, and between each terminal and housing, in all switch positions. Table 3 indicates terminals which shall have continuity. If there is continuity between any other terminals and/or housing, the switch shall be rejected. It is not necessary to check continuity between the two terminals at R.

NOTE:

Lower "R" terminal is grounded in start position. See Figure G.

- (2) Using the 11-8950-2 Tester or equivalent, make a high voltage test of insulation resistance between each terminal and all others that are open circuited, and between each terminal and housing in all switch positions.

NOTE:

Unless switch is push-to-prime type, PR terminal is not used.

Switch Position	Continuity Between Terminals:
OFF	R and GRD; L and GRD; S and PR (Push to Prime)
RIGHT	L and GRD
LEFT	R and GRD
BOTH	No Continuity
START	BAT and S; R and GRD; L, LR and BO
PUSH TO PRIME (BOTH POSITION)	BAT and PR
PUSH TO PRIME (START POSITION)	BAT, S and PR; R and GRD (Terminal Lug (1-23) installed); L, LR and BO

Table 3. Ignition/Starter Switch Logic

B. Testing GM Type Switches

- (1) Using 11-8950-2 tester or equivalent, check for continuity as shown in Table 4.
- (2) Perform high voltage insulation test as described in paragraph A(2) above.

C. Replace door lock or key if lock binds during operation or if key is removable in intermediate positions.

Key Position	Continuity To GROUND	
	Left	Right
OFF	X	X
R	X	-
L	-	X
BOTH	-	-

Table 4. GM Type Switch Logic

System Support Manual

IGNITION/STARTER SWITCHES AND DOOR LOCK KITS

INSTALLATION

- A. Using the pertinent illustration in Figure 6, connect wires to their proper terminals using screws (1-24) or nuts and lock washers (1-28, 1-5a). If right magneto is to be grounded during start, attach lug terminal (1-23) across terminals nearest the "R" mark.

Connections to the terminals are as follows:

GRD	Ground
R	Right Magneto "P" Lead
L	Left Magneto "P" Lead
LR	Left Magneto Retard Lead
BO	Booster Output (Starting Vibrator)
S	Starter Solenoid
BAT	Battery
PR	Primer Solenoid (Used only on switches with "push to prime" feature incorporated.)

- B. Lever (1-15) must be removed prior to installation of lever type switches. To remove lever (1-15), remove screw (1-13) and lock washer (1-14) and pull lever (1-15) straight off.
- C. Following lever removal, installation procedures for lever and key type are the same. The switches are installed from the rear of panel through a 15/16 inch hole with an alignment lug which fits in groove in switch housing. Recommended maximum panel thickness is 0.312 inches.
- D. Remove knurled nut (1-16), and seat hex nut (1-17) as close as possible to switch housing.
- E. Insert switch assembly through hole in panel with keyway in switch aligned with lug. If it is desirable to install a position indicating dial (1-22) it must be installed over and aligned with the keyway in the threaded end of housing extending from control panel.
- F. Tighten round knurled nut (1-16) over threaded portion of switch. If possible secure switch firmly in place by tightening hex nut (1-17) against rear of panel. Complete assembly is shown in Figure 7.

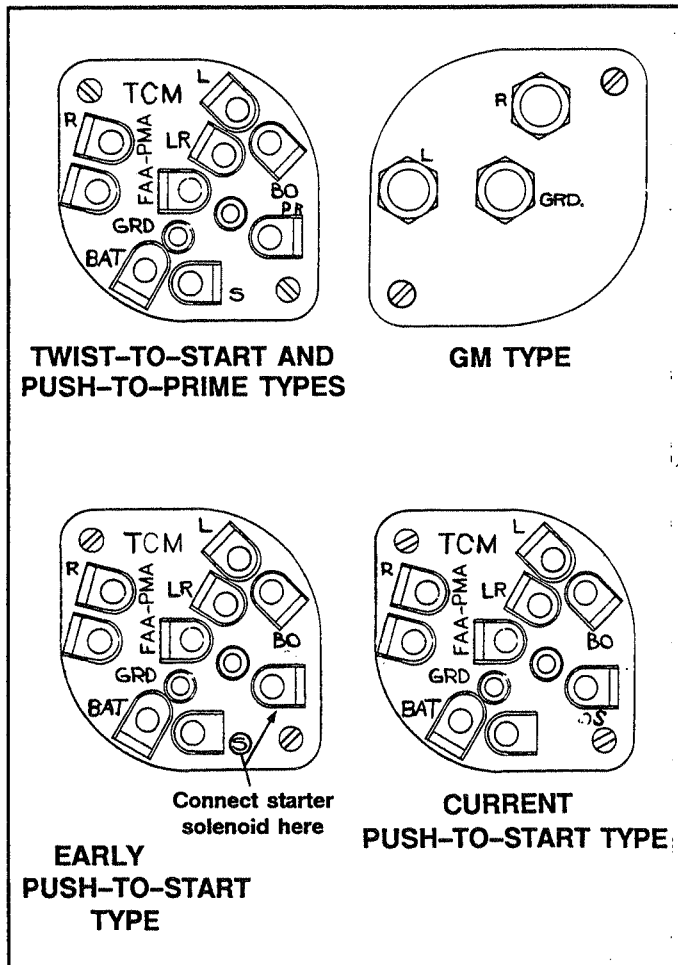

Figure 6. Switch Terminal Locations

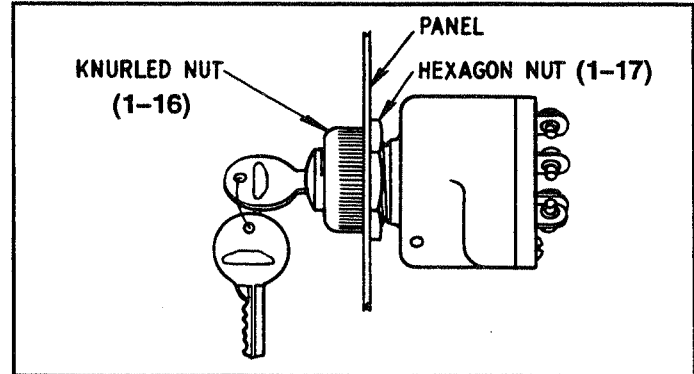

Figure 7. Side View of Mounted Switch

System Support Manual

IGNITION/STARTER SWITCHES AND DOOR LOCK KITS

IGNITION SWITCHES IGNITION SWITCH AND DOOR LOCK KITS DOOR LOCK KITS

IPL TABLE 1: EQUIPMENT COVERED

Part No.	Description	See IPL Fig.	No. Keys
10-357200-1	Switch Only, Key Type, Twist to Start	1	2
10-357200-10	Switch and Door Lock Kit	2	4
10-357200-11	Switch and Door Lock Kit	2	4*
10-357200-12	Switch Only, Key Type, Twist to Start	1	2*
10-357200-29	Switch and Door Lock Kit	2	2
10-357200-30	Switch and Door Lock Kit	2	2
10-357200-31	Switch and Door Lock Kit	2	2
10-357200-35	Switch and Door Lock Kit	2	2
10-357200-36	Switch and Door Lock Kit	2	2
10-357200-37	Switch and Door Lock Kit	2	2
10-357210-1	Switch Only, Key Type, Push to Start	1	2
10-357210-9	Switch Only, Key Type, Push to Start	1	3
10-357210-10	Switch and Door Lock Kit	2	2
10-357210-16	Switch and Door Lock Kit	2	2
10-357210-17	Switch and Door Lock Kit	2	2
10-357210-18	Switch and Door Lock Kit	2	2
10-357220-1	Switch Only, Key Type, Twist to Start, Push to Prime	1	2
10-357230-1	Switch Only, Lever Type, Twist to Start	1	-
10-357240-1	Switch Only, Lever Type, Push to Start	1	-
10-357250-1	Switch Only, Lever Type, Twist to Start, Push to Prime	1	-
10-357260-1	Switch Only, Lever Type (Without Lever), Twist to Start	1	-
10-357290-1	Switch Only, Key Type, GM (No Start Position)	1	2
10-357290-8	Switch and Door Lock Kit	2	2
10-357290-9	Switch and Door Lock Kit	2	4*
10-357290-10	Switch and Door Lock Kit	2	4*
10-357290-13	Switch Only, Key Type, GM (No Start Position)	1	2*
10-357509	Door Lock Kit	2	2
10-357703	Door Lock Kit	2	2
10-357704	Door Lock Kit	2	2

* Keys marked "CESSNA"

System Support Manual

IGNITION/STARTER SWITCHES AND DOOR LOCK KITS

IPL TABLE 2: IGNITION SWITCHES

Fig. & Item	Description	Part Number											
			10-357200-1	10-357200-12	10-357210-1	10-357210-9	10-357220-1	10-357230-1	10-357240-1	10-357250-1	10-357260-1	10-357290-1	10-357290-13
1-1	. Screw	10-126665	3	3	3	3	3	3	3	3	3	3	3
1-2	. Support Kit	10-357510	1	1			1	1			1	1	
	. Support Kit	10-357515			1	1				1			
1-2a	. Support Assembly ¹	10-51110										1	1
1-3	. Contact	*	3	3	3	3	3	3	3	3	3		
1-3a	. Contact, Long	*										1	1
1-3b	. Contact, Short	*										1	1
1-4	. Spring	*	3	3	3	3	3	3	3	3	3		
1-5	. Washer	*	1	1	1	1	1	1	1	1	1		
1-5a	. Washer, Lock	*										7	7
1-6	. Washer	*	1	1	1	1	1	1	1	1	1		
1-6a	. Washer	*										1	1
1-7	. Rotor	*	1	1				1			1		
	. Rotor	*			1	1	1		1	1			
1-7a	. Rotor	*										1	1
1-8	. Pin	*			1	1	1		1	1			
1-9	. Bracket	*			2	2	2		2	2		2	2
1-10	. Spring	*			1	1	1		1	1			
1-10a	. Spring, Contact	*										2	2
1-11	. Spring	*	1	1	1	1	1	1	1	1	1		
1-12	. Retainer - Spring	*	1	1	1	1	1	1	1	1	1		
1-13	. Screw	*						1	1	1	1		
1-14	. Washer	*						1	1	1	1		
1-15	. Lever	*						1	1	1			
1-16	. Nut	*	1	1	1	1	1	1	1	1		1	1
1-17	. Nut	*	1	1	1	1	1	1	1	1	1	1	1
1-18	. Shaft	*						1			1		
	. Shaft	*								1			
	. Shaft	*							1				
1-19	. Bushing	*			1	1							
1-20	. Switch Lock (w/3 Standard Keys)	*				1							
	. Switch Lock (w/2 Cessna Keys)	*		1									1
	. Switch Lock (w/2 Standard Keys)	*	1									1	
	. Switch Lock (w/2 Standard Keys)	*			1								
	. Switch Lock (w/2 Standard Keys)	*					1						
1-21	. Housing - Switch	*	1	1	1	1	1	1	1	1	1	1	1
1-22	. Dial	10-51127											
	Dial (Twist to Start)	10-126676	**	**				**	**		**	1	1
	Dial (Twist to Start/Prime)	10-126694					**	**	**	**			
	Dial (Push to Start)	10-187468			**	**			**	**			
1-23	. Terminal - Lug	10-126656	1	1	1	1	1	1	1	1	1		
1-24	. Screw Lock Washer	10-126648	9	9	8	8	9	9	8	9	9		
1-25	. Screw ¹	*										1	1
1-26	. Screw ¹	*										2	2
1-27	. Washer ¹	*										3	3
1-28	. Nut ¹	*										6	6

1 ITEMS 25 THROUGH 5a (QTY 6) INCLUDED WITH ITEM 2a

* NOT AVAILABLE AS A SPARE. SHOULD REPLACEMENT BE NECESSARY, REPLACE ENTIRE SWITCH.

** DIAL NOT SUPPLIED WITH SWITCH, PURCHASE SEPARATELY AS INDICATED.

System Support Manual

IGNITION/STARTER SWITCHES AND DOOR LOCK KITS

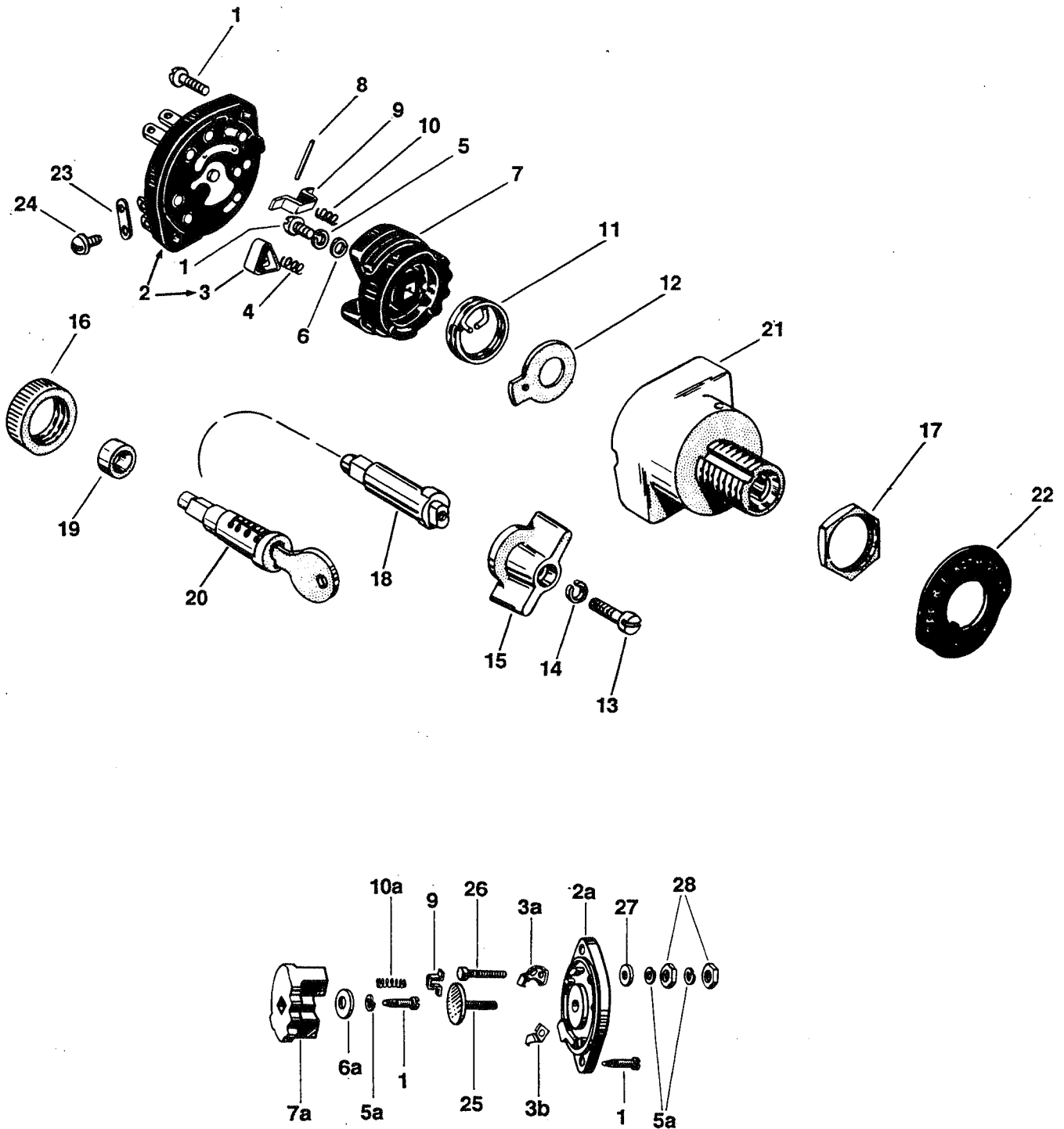

IPL Figure 1. Exploded View of Switches

System Support Manual

IGNITION/STARTER SWITCHES AND DOOR LOCK KITS

IPL TABLE 3. IGNITION SWITCH AND DOOR LOCK KITS

Fig. & Item	Description	Part Number	10-357200-10	10-357200-11	10-357200-29	10-357200-30	10-357200-31	10-357200-35	10-357200-36	10-357200-37	10-357210-10	10-357210-16	10-357210-17	10-357210-18	10-357290-8	10-357290-9	10-357290-10	10-357509	10-357703	10-357704	
			2-1	. Ignition Switch . Ignition Switch . Ignition Switch . Ignition Switch . Ignition Switch	10-357200-1 10-357200-12* 10-357210-1 10-357290-1 10-357290-13*	1	1	1	1	1	1	1	1	1	1	1	1	1	1	1	
2-2	. Dial . Dial	10-126676 10-187468	**	**	1	1	1	1	1	1	1	1	1	1							
2-3	. Door Lock and 2 Keys 180°	10-357205*		2												1	2				
2-3a	. Door Lock and 2 Keys 90°	10-357496			1	1	1					1	1	1					1		
2-3b	. Door Lock and 2 Keys 180°	10-357596							1	2										2	1
2-3c	. Door Lock and 2 Keys 90°	10-357597						1	1	1										1	1
2-3d	. Door Lock and 2 Keys 180°	10-377008	1																		
2-3e	. Door Lock and 2 Keys 180°	10-377009	1																		
2-3f	. Door Lock and 2 Keys 180°	10-377028				1	2				2		1	2	2			2			

* Keys marked "CESSNA"
** Dial not supplied with kit.

System Support Manual

IGNITION/STARTER SWITCHES AND DOOR LOCK KITS

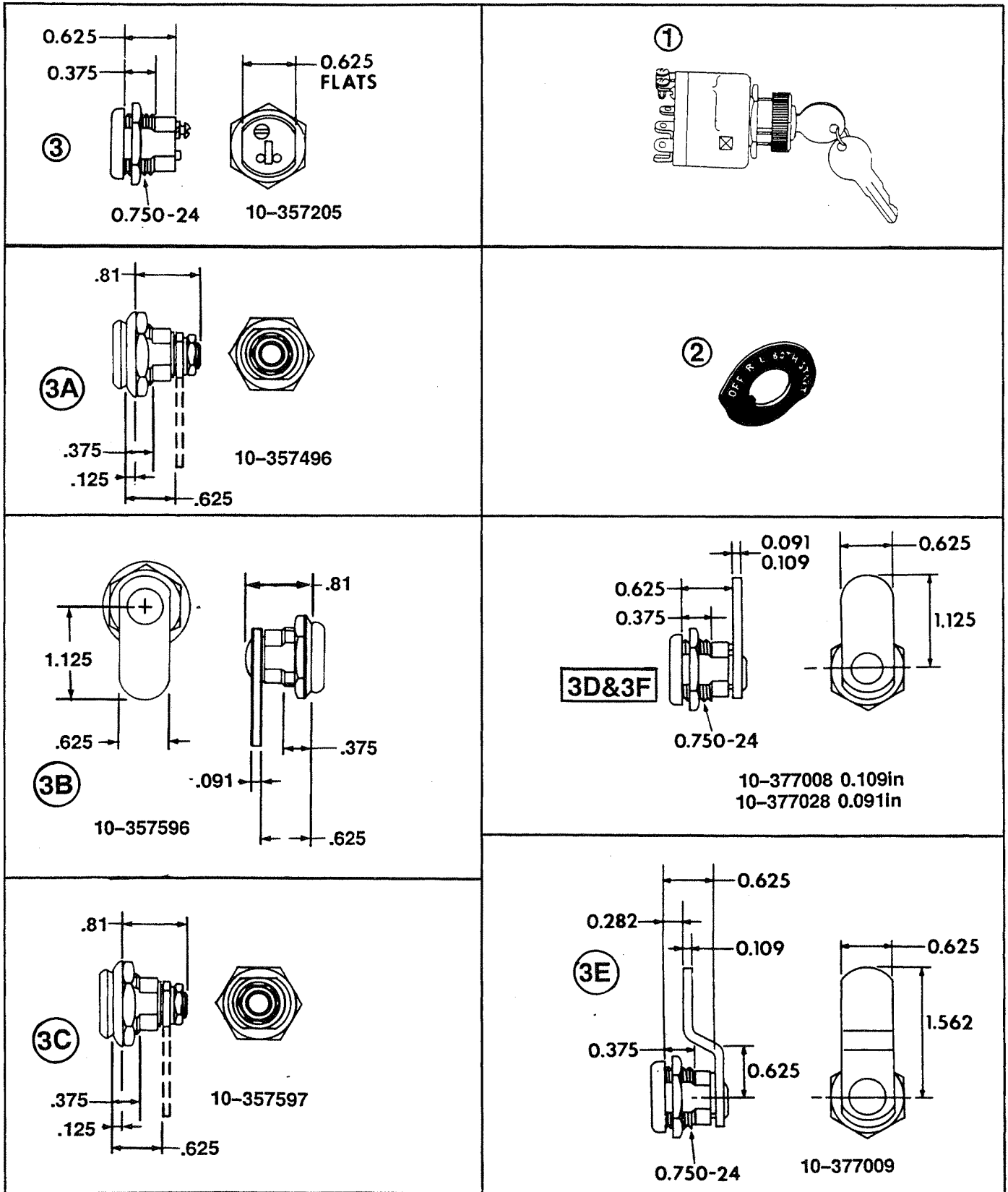

IPL Figure 2. Ignition Switch and Door Lock Kits

System Support Manual
IGNITION/STARTER SWITCHES AND DOOR LOCK KITS

IPL TABLE 4. IGNITION SWITCH AND DOOR LOCK KITS
NUMERICAL PARTS LIST

Part Number	Nomenclature	Figure and Item No.
10-51110	Support	1-2a
10-51127	Dial	1-22
10-126648	Screw and Lock Washer	1-24
10-126656	Terminal - Lug	1-23
10-126665	Screw	1-1
10-126676	Dial (Twist to Start)	1-22
10-126694	Dial (Twist to Start/Push to Prime)	1-22
10-187468	Dial (Push to Start)	1-22
10-357205	Door Lock and 2 Keys	2-3
10-357496	Door Lock and 2 Keys	2-3a
10-357510	Support Kit	1-2
10-357515	Support Kit	1-2
10-357596	Door Lock and 2 Keys	2-3b
10-357597	Door Lock and 2 Keys	2-3c
10-377008	Door Lock and 2 Keys	2-3d
10-377009	Door Lock and 2 Keys	2-3e
10-377028	Door Lock and 2 Keys	2-3f

System Support Manual

IGNITION/STARTER SWITCHES AND DOOR LOCK KITS

IPL TABLE 5: SUPERSEDED AND DISCONTINUED ITEMS

OLD P/N	SUPERSEDED BY	OLD P/N	SUPERSEDED BY
10-32890-1	*	10-357200-19	*
10-34365	*	10-357200-21	*
10-51104	*	10-357210-2	*
10-51104-1	10-357290-1	10-357210-3	*
10-51150-1	*	10-357210-4	*
10-51150-2	*	10-357210-5	*
10-51160	*	10-357210-6	*
10-51180-1	*	10-357210-7	*
10-81388-1	*	10-357210-8	*
10-126630-1	10-357230-1	10-357210-11	*
10-126630-4	*	10-357230-2	*
10-126660-1	10-357250-1	10-357260-2	*
10-126660-4	*	10-357260-3	*
10-126680-1	10-357220-1	10-357260-4	*
10-126680-2	10-357210-1	10-357260-5	*
10-126680-6	*	10-357260-6	*
10-126690-1	10-357200-1	10-357260-7	*
10-126690-2	*	10-357270-1	*
10-126690-4	*	10-357270-2	*
10-126690-6	*	10-357270-3	*
10-126690-8	*	10-357270-4	*
10-126690-11	*	10-357270-5	*
10-126690-12	*	10-357270-6	*
10-126690-13	*	10-357270-7	*
10-126690-14	*	10-357270-8	*
10-126690-15	*	10-357270-9	*
10-157440-1	*	10-357270-10	*
10-157440-2	*	10-357270-11	*
10-157440-3	*	10-357280-1	*
10-157440-4	*	10-357280-2	*
10-157440-21	*	10-357290-2	*
10-357200-2	*	10-357290-3	*
10-357200-3	*	10-357290-4	*
10-357200-4	*	10-357290-5	*
10-357200-5	*	10-357290-6	*
10-357200-6	*	10-357290-7	*
10-357200-7	*	10-357290-11	*
10-357200-8	*	10-357290-14	*
10-357200-9	*	10-357290-15	*
10-357200-13	*	10-357290-16	*
10-357200-14	*	10-357310-1	*
10-357200-15	*	10-357310-2	*
10-357200-16	*	10-357310-3	*
10-357200-17	*	10-357310-4	*
		10-357310-5	*

* Superseding P/N may be supplied upon request.



Continental Motors, Inc.
www.continentalmotors.aero