



**Chapter 1. INTRODUCTION**  
**CONTENTS**

**Chapter 1. Introduction..... 1-1**

1-1. Scope and Purpose of This Manual ..... 1-2

    1-1.1. Advisories ..... 1-2

    1-1.2. Using this Manual..... 1-2

    1-1.3. Compliance ..... 1-3

    1-1.4. Order of Precedence ..... 1-4

1-2. Publications ..... 1-5

    1-2.1. Service Documents ..... 1-5

    1-2.2. Related Publications ..... 1-6

    1-2.3. Publication Access..... 1-7

    1-2.4. Publication Changes ..... 1-7

1-3. TCM Contact Information ..... 1-8

**LIST OF TABLES**

Table 1-1. Related Publications ..... 1-6

## 1-1. Scope and Purpose of This Manual

This manual provides instructions for installing and operating the following turbocharged aircraft engines, referred to collectively as the “TSIO-550 Series” engines, manufactured by Teledyne Continental Motors (TCM):

- TSIO-550-B
- TSIO-550-C
- TSIO-550-E
- TSIO-550-G

Instructions in this manual are specific to the TSIO-550 Series engines. For information specific to other TCM engine series, accessories, or the airplane, refer to the appropriate manual. Chapters are arranged in sequential order to install, test, and operate the engine.

Chapter 2 contains engine description and specifications. Chapter 4 provides installation instructions and illustrations for installing the engine. Chapter 5 identifies inspection, service intervals, and operational tests. Chapter 6 contains engine storage instructions and steps to return a stored engine to operation. Chapter 7 provides supplemental information for the airplane flight manual (AFM) and pilot operating handbook (POH) in regards to specific engine operating procedures. Appendix A contains a glossary of common terms and acronyms used throughout the manual; Appendix B provides torque specifications, and Appendix C contains standard maintenance practices.

### 1-1.1. Advisories

This manual utilizes three types of advisories; defined as follows:

#### **WARNING**

**A warning emphasizes information which, if disregarded, could result in severe injury to personnel or equipment failure.**

*CAUTION: Emphasizes certain information or instructions, which if disregarded, may result in damage to the engine or accessories.*

**NOTE:** Provides special interest information, which may facilitate performance of a procedure or operation of equipment.

Warnings and cautions precede the steps to which they apply; notes are placed in the manner which provides the greatest clarity. Warnings, cautions, and notes do not impose undue restrictions. Failure to heed advisories will likely result in the undesirable or unsafe conditions the advisory was intended to prevent. Advisories are inserted to ensure maximum safety, efficiency, and performance. Abuse, misuse, or neglect of equipment can cause eventual engine malfunction or failure.

### 1-1.2. Using this Manual

This manual, the Maintenance and Overhaul Manual, applicable service documents, and other related publications constitute the Instructions for Continued Airworthiness (ICAs) prepared by TCM and approved by the FAA. TCM prepared this manual in a user-



friendly format suited equally for electronic viewing and print. Figures in this manual are for reference only, depicting the most prominent configuration in the engine series. Consult the parts catalogs for an illustrated parts breakdown of your specific engine and each subsystem.

Teledyne Continental Motors (TCM) provides Instructions for Continued Airworthiness based on the design, testing, and certification of engines and parts for which TCM is the holder of the Type Certificate (TC) or Parts Manufacturing Approval (PMA) issued by the Federal Aviation Administration (FAA).

**WARNING**

**Instructions in TCM manuals are applicable *only* to engines and parts supplied by TCM. TCM ICAs *should not* be used for non-TCM parts.**

Installation of non-TCM parts on a TCM engine constitutes a deviation from TCM type-design criteria. TCM has not participated in design, test, or certification of any non-TCM parts. TCM does not provide product manufacturing specifications to aftermarket parts manufacturers and accepts no liability for the suitability, durability, longevity, or safety of such parts installed on TCM engines. Installation of non-TCM parts on a TCM engine must be performed using Instructions for Continued Airworthiness prepared by the manufacturer and approved by the FAA for the subject installation.

### 1-1.3. Compliance

The owner/operator and designated mechanic are responsible for ensuring the engine is maintained in an airworthy condition, including compliance with applicable service documents and FAA Airworthiness Directives. Engine service life is calculated based on compliance with the aircraft and engine manufacturer's required instructions, inspections, and maintenance schedule. Failure to comply may void the engine warranty.

**WARNING**

**Prior to authorizing engine installation or maintenance, the owner must ensure the mechanic meets the requirements of FAR 65 and must comply with FAR parts 43, 91, and 145, as applicable.**

Except for FAR part 43.3 authorized owner maintenance, TCM ICAs are written for exclusive use by FAA (or equivalent authority) licensed mechanics or FAA (or equivalent authority) certified repair center employees working under the supervision of an FAA licensed mechanic. Information and instructions contained in this manual anticipate the user possesses and applies the knowledge, training, and experience commensurate with the requirements to meet the prerequisite FAA license and certification requirements. No other use is authorized.

**WARNING**

**Failure to comply with ICAs may result in injury or subsequent engine failure. Pursuant to Federal Aviation Regulation (FAR) § 43.13, each person performing maintenance, alteration or preventive maintenance on an engine or accessory must use methods, techniques and practices set forth in the Instructions for Continued Airworthiness or other methods, techniques, and practices acceptable to the Administrator.**

This manual must be used in conjunction with FAA Advisory Circular 43.13-1B “Acceptable Methods, Techniques, and Practices” as well as Teledyne Continental Motors Maintenance and Overhaul Manual, service documents, related publications and accessory manufacturer’s instructions. Pursuant to Federal Aviation Regulation (FAR) §43.13, each person performing maintenance, alteration, or preventive maintenance on the engine or accessories must use methods, techniques, and practices prescribed in the ICAs.

**1-1.4. Order of Precedence**

Teledyne Continental Motors (TCM) engine operating instructions are generated prior to and independently of the aircraft operating instructions. TCM operating instructions are developed using factory controlled parameters that are not necessarily the same as those specifications required to satisfy a specific aircraft/engine installation.

**WARNING**

**The aircraft operator must use the airframe manufacturer’s operating instructions found in the Airplane Flight Manual/ Pilot’s Operating Handbook (AFM/POH) while operating the aircraft unless the AFM/POH directs otherwise.**

Refer to the AFM/POH published by the airframe manufacturer for operating instructions and specifications relative to your aircraft.

**WARNING**

**New or updated Instructions for Continued Airworthiness may be contained in TCM service documents. Service documents applicable to the engine or accessories within the scope of this manual must be consulted and complied with prior to performing any installation, maintenance, or overhaul function.**

New information contained in service documents may override the instructions contained in this manual. Prior to commencing engine maintenance, consult TCMLINK to verify the current status of the ICAs relating to the intended procedure.



## 1-2. Publications

### 1-2.1. Service Documents

Six categories of Service Documents may be issued by TCM ranging from mandatory (Category 1) to informational (Category 6). Definitions of the categories are listed below:

NOTE: Upon FAA approval, all TCM service documents are published and available on TCMLINK. Service Documents which contain updates to the Instructions for Continued Airworthiness must be inserted in the affected manual until such time the manual is revised to include the Service Document Instructions or the Service Document is cancelled or superseded. Affected manuals will be referenced in all Service Documents containing updates to the manufacturer's Instructions for Continued Airworthiness.

#### **Category 1: Mandatory Service Bulletin (MSB)**

Used to identify and correct a known or suspected safety hazard which has been incorporated in whole or in part into an Airworthiness Directive (AD) issued by the FAA or have been issued at the direction of the FAA by the manufacturer requiring compliance with an already-issued AD (or an equivalent issued by another country's airworthiness authority). May contain updates to TCM's Instructions for Continued Airworthiness to address a safety issue.

#### **Category 2: Critical Service Bulletin (CSB)**

This category identifies a condition that threatens continued safe operation of an aircraft, persons or property on the ground unless some specific action (inspection, repair, replacement, etc.) is taken by the owner or operator. Documents in this category are candidates for incorporation into an FAA Airworthiness Directive. May contain updates to TCM's Instructions for Continued Airworthiness to address a safety issue.

#### **Category 3: Service Bulletin (SB)**

Information which the product manufacturer believes may improve the inherent safety of an aircraft or aircraft component; this category includes the most recent updates to Instructions for Continued Airworthiness.

#### **Category 4: Service Information Directive (SID)**

The manufacturer directs the owner/operator/mechanic in the use of a product to enhance safety, maintenance or economy. May contain updates to TCM's Instructions for Continued Airworthiness in the form of maintenance procedures or specifications.

#### **Category 5: Service Information Letter (SIL)**

This category includes all information (not included in categories 1 through 4) that may be useful to the owner/operator/technician. May contain updates to TCM's Instructions for Continued Airworthiness for optional component installations, which are not covered in the Applicable Operator, Maintenance, or Overhaul Manuals.

#### **Category 6: Special Service Instruction (SSI)**

This category is used to address an issue limited to specific model and/or serial number engines. TCM will distribute SSI notification directly to the affected engine's owners. SSIs will not be included in the general service document set but will be made available through



TCM Customer Service to owners of the affected engines only. An SSI may contain updates to the Instructions for Continued Airworthiness applicable to the listed engines.

**1-2.2. Related Publications**

The chart below lists related publications, source, and accessibility relevant to installing TSIO-550 Series engines.

**WARNING**

**Use only the latest revision of all publications. Using superseded information jeopardize engine airworthiness.**

| Table 1-1. Related Publications  |                      |                       |                |                             |
|--|----------------------|-----------------------|----------------|-----------------------------|
| Publication  | Supplied With Engine | Internet via TCMLINK* | Order From TCM | Available From Manufacturer |
| <b>TCM Publications</b>  |                      |                       |                |                             |
| Maintenance and Overhaul Manual (M-18)   | No                   | Yes                   | Yes            | N/A                         |
| Starter Service Instructions (X30592)  | No                   | Yes                   | Yes            | N/A                         |
| Lightweight Starter Service Instructions (STR-01)  | No                   | Yes                   | Yes            | N/A                         |
| Alternator Service Instructions (X30531-3)   | No                   | Yes                   | Yes            | N/A                         |
| TCM Ignition System Master Service Manual (X40000)   | No                   | Yes                   | Yes            | N/A                         |
| Parts Catalogues   | No                   | Yes                   | No             | N/A                         |
| Detailed Model Specifications  | No                   | No                    | Yes            | N/A                         |
| Service Documents  | No                   | Yes                   | Yes            | N/A                         |
| Material Handling Specifications (MHS)   | No                   | No                    | Yes            | N/A                         |
| <b>Supplier Bulletins</b>  |                      |                       |                |                             |
| FAA Airworthiness Directives   | No                   | Yes                   | No             | N/A                         |
| Accelagold   | No                   | Reference             | No             | Yes                         |
| Emhart Fastening Technologies  | No                   | Reference             | No             | Yes                         |
| Slick Aircraft Products  | No                   | No                    | No             | Yes                         |
| <b>Accessory Documents</b>   |                      |                       |                |                             |
| Slick Ignition Systems Service Index (Form F-1100)   | No                   | No                    | No             | Yes                         |
| Kelly Aerospace Power Systems Overhaul Manual Vol I & II, Aircraft Turbocharger (400600-0000)  | No                   | No                    | No             | Yes                         |
| Kelly Aerospace Power Systems Troubleshooting Performance Guide (400888-0000)  | No                   | No                    | No             | Yes                         |
| Kelly Aerospace Power Systems Aircraft Turbocharger Valves and Controls Overhaul Manual (400999-0000)  | No                   | No                    | No             | Yes                         |
| Kelly Aerospace Power Systems Alternator Overhaul (OE-A2)  | No                   | Reference             | No             | Yes                         |
| Kelly Aerospace Power Systems Lightweight Series Alternator Overhaul Manual (ES1010-1/2)   | No                   | Reference             | No             | Yes                         |
| Kelly Aerospace Power Systems Lightweight Series Gear Driven Alternator Overhaul Manual (ES1011)   | No                   | Reference             | No             | Yes                         |
| *TCMLINK Information Services® provides 24-hour-a-day access via the Internet. If you are a TCMLINK subscriber, you can access TCMLINK to confirm and review the latest revision of this manual. If you have not subscribed to TCMLINK through TCM and are using hardcopies, contact TCM listed in the "TCM Contact Information" section of this chapter to confirm that you have the latest revision of the manual. |                      |                       |                |                             |



### 1-2.3. Publication Access

TCMLINK Alpha Services, Information Services, Aviator Services, and FBO Services programs provide an array of benefits including access to electronic versions of TCM technical publications (manuals, service documents, and parts catalogs) via the Internet. Aviator Services and Alpha Services memberships are free to TCM engine owners. FBO and Information Services are available with a paid subscription fee. Contact a TCM distributor to discuss service subscription options and pricing or visit our website (See Contact Information).

Printed TCM publications may be ordered through Teledyne Continental Motors authorized distributors or via the Internet at TCMLINK. Your TCM printed document purchase includes three years of updates at no extra charge. Use “TCM Contact Information”, or our Internet website.

### 1-2.4. Publication Changes

The instructions in this manual represent the best and most complete information available at the time of publication. Product or process improvements may trigger changes to existing product design specifications or procedures contained in publications. As new technical information becomes available, TCM will deliver the updated information to the customer in the most expedient manner.

#### **WARNING**

**New information may be contained in Teledyne Continental Motors service documents. Service documents applicable to engines and accessories within the scope of this manual must be complied with as defined in these documents. This manual, together with TCM’s Maintenance and Overhaul Manual (M-18 and other related publications noted constitute the Instructions for Continued Airworthiness (ICAs) prepared by Teledyne Continental Motors and approved by the Federal Aviation Administration (FAA).**

Teledyne Continental Motors releases publication changes in the form of either change pages or complete publication revisions, depending upon the extent of change. Service Documents may supplement or replace technical information contained in one publication or an entire series of publications. Such Service Documents represent a change to the published ICA until the individual publications incorporate the latest technical information.

#### 1-2.4.1. Update/Change Distribution

Updates are available via TCMLINK upon notification of FAA document approval. TCM notifies engine owners of technical publication changes free of charge. TCM notifies current TCMLINK service subscribers by mail as publications are updated. Current subscribers receive a complete publication library on CD delivered quarterly. Printed publication subscribers receive printed changes and revisions as they are released.

### **1-2.4.2. Suggestions and Corrections**

Teledyne Continental Motors solicits and encourages user comments regarding suggested changes to this manual. Direct recommended changes or questions to the attention of “Publications” at the TCM address listed under “TCM Contact Information.”

Notify TCM Customer Service immediately, using our toll-free number, if you discover incorrect information which adversely affects safety.

### **1-3. TCM Contact Information**

Teledyne Continental Motors is available to answer technical questions and encourages suggestions regarding products, parts, or service. If customers have an inquiry or require technical assistance, they should contact their local TCM distributor or TCM field representative. To contact TCM, refer to the contact information below:

Teledyne Continental Motors, Inc.  
P. O. Box 90  
Mobile, AL 36601

Toll Free Customer Service Phone Numbers: 888-826-5465

Internet Web Site Address: <http://www.tcmlink.com>





Chapter 2. ENGINE DESCRIPTION

CONTENTS

Chapter 2. Engine Description..... 2-1
2-1. General Engine Description..... 2-3
2-1.1. Engine Model Number Definition ..... 2-5
2-1.2. Cylinder Number Designations ..... 2-5
2-2. Detailed Engine Description..... 2-6
2-2.1. Crankcase ..... 2-6
2-2.2. Engine Drive Train ..... 2-7
2-2.3. Cylinders..... 2-10
2-2.4. Lubrication System..... 2-11
2-2.5. Fuel System ..... 2-15
2-2.6. Starter Assembly..... 2-18
2-2.7. Alternator..... 2-18
2-2.8. Ignition System..... 2-19
2-2.9. Engine Cooling ..... 2-20
2-2.10. Induction System ..... 2-21
2-2.11. Turbocharger and Exhaust..... 2-21
2-3. Engine Specifications and Operating Limits ..... 2-22
2-3.1. TSIO-550-B Specifications and Operating Limits..... 2-23
2-3.2. TSIO-550-C Specifications and Operating Limits..... 2-25
2-3.3. TSIO-550-E Specifications and Operating Limits..... 2-27
2-3.4. TSIO-550-G Specifications and Operating Limits ..... 2-29
2-3.5. TSIO-550 Accessory Drive Ratios ..... 2-31
2-3.6. Oil Specifications ..... 2-31
2-3.7. Performance Data ..... 2-32

LIST OF TABLES

Table 2-1. TSIO-550-B Specifications & Operating Limits..... 2-23
Table 2-2. TSIO-550-C Specifications & Operating Limits..... 2-25
Table 2-3. TSIO-550-E Specifications & Operating Limits ..... 2-27
Table 2-4. TSIO-550-G Specifications & Operating Limits ..... 2-29
Table 2-5. Accessory Drive Ratios, Rotation, Speed, Torque & Moments..... 2-31
Table 2-6. Engine Oil Type Requirements ..... 2-31



**LIST OF FIGURES**

Figure 2-1. TSIO-550 Top and Side Views ..... 2-4  
Figure 2-2. Engine Model Identifier ..... 2-5  
Figure 2-3. Cylinder Number Designation ..... 2-5  
Figure 2-4. Crankcase ..... 2-6  
Figure 2-5. Engine Drive Train..... 2-7  
Figure 2-6. Crankshaft ..... 2-8  
Figure 2-7. Cylinder Assembly ..... 2-10  
Figure 2-8. Lubrication Schematic ..... 2-12  
Figure 2-9. Oil Pump ..... 2-13  
Figure 2-10. Oil Cooler..... 2-14  
Figure 2-11. Fuel System Schematic ..... 2-15  
Figure 2-12. Fuel Pump ..... 2-16  
Figure 2-13. Starting System ..... 2-18  
Figure 2-14. Ignition System Schematic..... 2-19  
Figure 2-15. Engine Cooling Airflow ..... 2-20  
Figure 2-16. Typical Crossflow Induction Airflow ..... 2-21  
Figure 2-17. Turbocharger and Exhaust ..... 2-22  
Figure 2-18. TSIO-550-B Fuel Flow vs. Brake Horsepower..... 2-33  
Figure 2-19. TSIO-550-B Sea Level Performance ..... 2-34  
Figure 2-20. TSIO-550-B Altitude Performance ..... 2-35  
Figure 2-21. TSIO-550-C Fuel Flow vs. Brake Horsepower..... 2-36  
Figure 2-22. TSIO-550-C Sea Level Performance ..... 2-37  
Figure 2-23. TSIO-550-C Altitude Performance ..... 2-38  
Figure 2-24. TSIO-550-E Fuel Flow vs. Brake Horsepower..... 2-39  
Figure 2-25. TSIO-550-E Sea Level Performance ..... 2-40  
Figure 2-26. TSIO-550-E Altitude Performance ..... 2-41  
Figure 2-27. TSIO-550-G Fuel Flow vs. Brake Horsepower ..... 2-42  
Figure 2-28. TSIO-550-G Sea Level Performance ..... 2-43  
Figure 2-29. TSIO-550-G Altitude Performance..... 2-44



## **2-1. General Engine Description**

The TSIO-550-B, C, E, and G engines are six cylinder fuel injected, turbocharged engines with horizontally opposed air cooled cylinders designed for variable-pitch propeller applications. The engine cylinders are a cross flow design with overhead inclined valves. The downdraft cylinder head intake inlets are cast in the top of the cylinder head; downdraft exhaust outlets exit the bottom of the cylinder.

The TSIO-550 Series engines 550 cubic inch displacement is achieved using a cylinder design with a 5.25 inch diameter bore and a 4.25 inch stroke. The TSIO-550-B, C, E and G engine series utilizes the Permold Series crankcase design. The engine dry weight is 442.10 lbs. without accessories. For the total weight of specific engine configurations, refer to the engine Detailed Model Specification.

The engine is provided with four engine mounts designed for a focalized bed mount. A crankcase breather port is located on the oil filler neck on the 2-4-6 side of the crankcase between number 2 and number 4 cylinders. A .374-24 UNF threaded port is located near the bottom side of the cylinder head to accommodate a bayonet thermocouple.

The engine lubrication is provided by a wet sump, high pressure oil system. The engine lubrication system includes the internal engine driven pressure oil pump, engine mounted oil cooler, oil sump, full flow oil filter, oil pressure relief valve, and pressure instrumentation. The oil cooler is mounted on the left crankcase half behind the number 2 cylinder. A vernatherm valve allows oil flow into the engine if an oil restriction occurs in the external oil cooler and during cold starting.

The TSIO-550 Permold Series engines incorporate a downdraft balanced port induction system with an engine mounted throttle body. Engine manifold pressure is controlled by the throttle plate and is measured at the .125 - 27 NPTF port located on the induction manifold near the throttle.

The TSIO-550 Permold Series engines incorporate dual turbochargers and dual aftercoolers. The exhaust bypass for the turbine sections are connected to a single exhaust wastegate that is controlled by a sloped controller.

The TSIO-550 Permold Series engines are equipped with a TCM Continuous Flow Fuel Injection system that meters fuel flow as a function of engine speed, throttle angle, mixture control angle, and turbocharger compressor discharge air pressure. The metered fuel is fed to continuous flow air bled injector nozzles located at each cylinder intake port. Fuel drains are provided at the bottom of each cylinder.

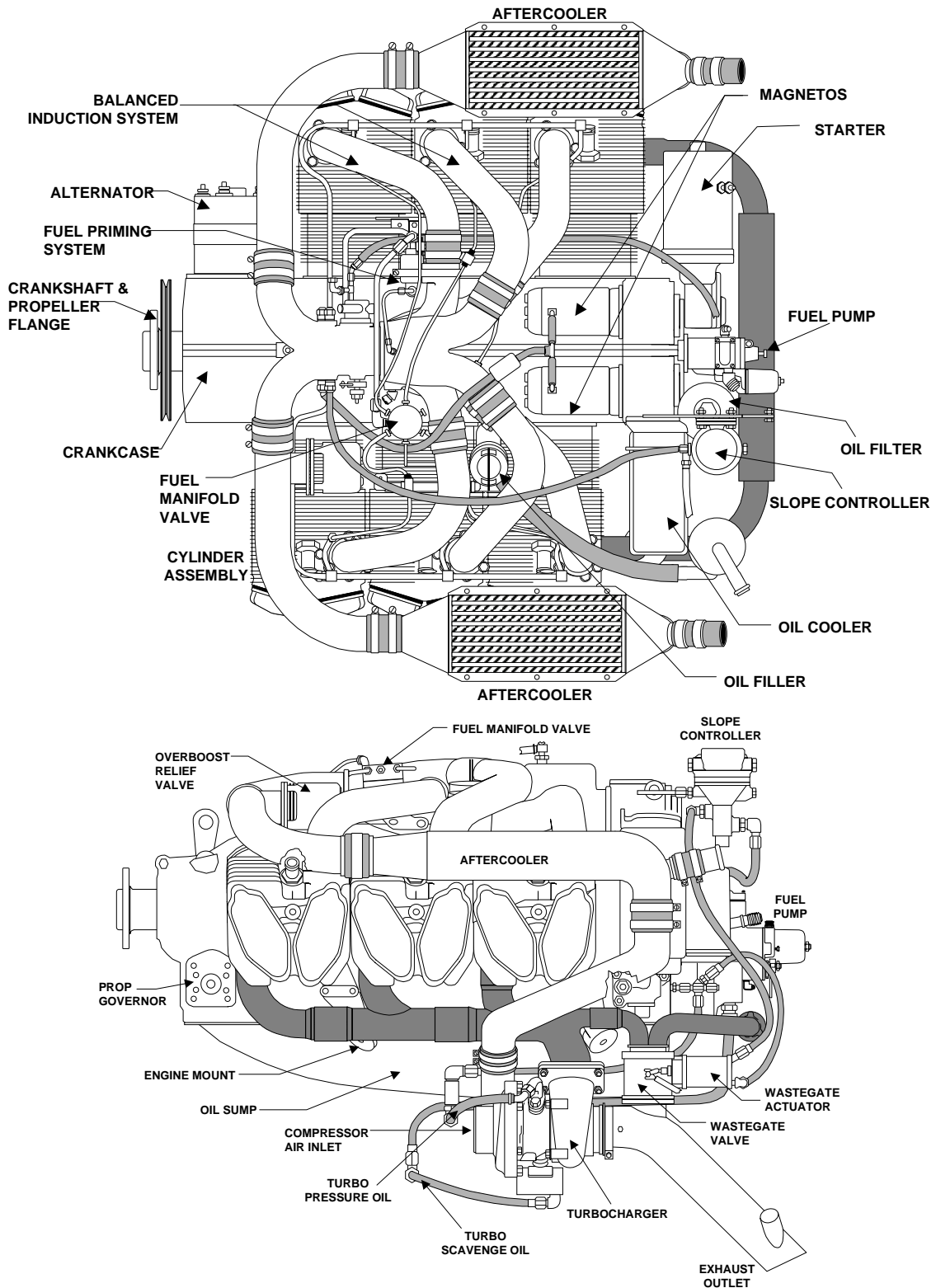

Figure 2-1. TSIO-550 Top and Side Views



### 2-1.1. Engine Model Number Definition

The description of each alphanumeric character in the engine model number is given below for the example engine model number TSIO-550-B1B (Figure 2-2).

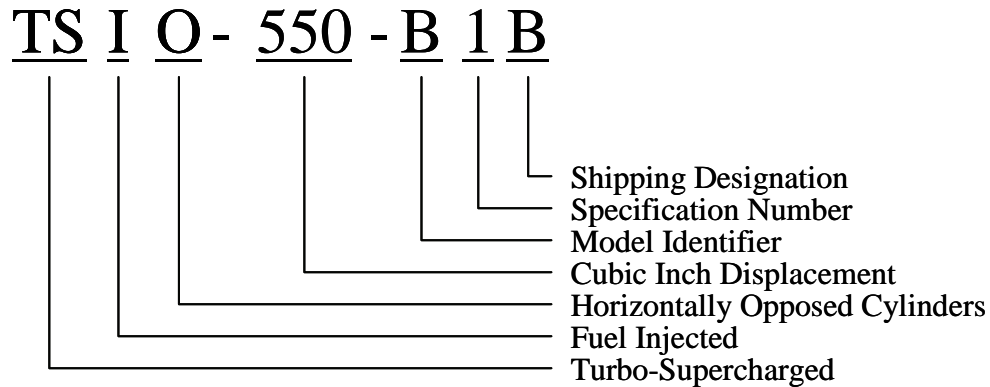

Figure 2-2. Engine Model Identifier

### 2-1.2. Cylinder Number Designations

Refer to Figure 2-3:

- The front of the engine is the end closest to the propeller and the rear of the engine is the accessory end
- Viewed from the rear of the engine, the left-side cylinders are designated by even numbers 2-4-6, with Cylinder 2 being closest to the rear.
- The right side cylinders have odd number sequential designation 1-3-5, with Cylinder 1 being closest to the rear.
- Firing order of the engine is 1-6-3-2-5-4.

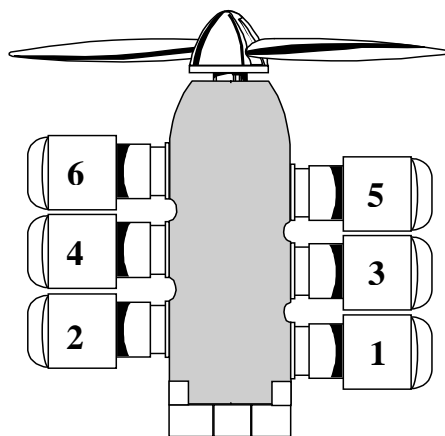

Figure 2-3. Cylinder Number Designation

## 2-2. Detailed Engine Description

### 2-2.1. Crankcase

The crankshaft is composed of two aluminum alloy castings joined along the center vertical plane. The individual castings with studs and inserts will be referred to as left and right crankcases throughout the manual.

Bosses molded in the castings are line bored in the assembled casting to form bearings for the camshaft and saddles for precision main bearing inserts. Guides are bored through lateral bosses for hydraulic tappets and on the left crankcase half for the governor drive shaft gear. A needle bearing bore is located on the right crankcase half at the rear main bearing saddle for the starter adapter and needle bearing.

Cylinder mounting pads on the left crankcase are farther forward than the corresponding pads on the right crankcase to permit each connecting rod to work on a separate crankpin. There are seven studs and two through bolts for attaching cylinder base flanges. The propeller governor mount pad located on the left hand lower front corner of the left crankcase half. An alternator pad is located on the right Permold crankcase forward of the number five cylinder mount pad.

The crankcase interior is ventilated by an integral breather in the oil filler adapter inserted in a machined hole between the number two and four cylinders on the left crankcase half.

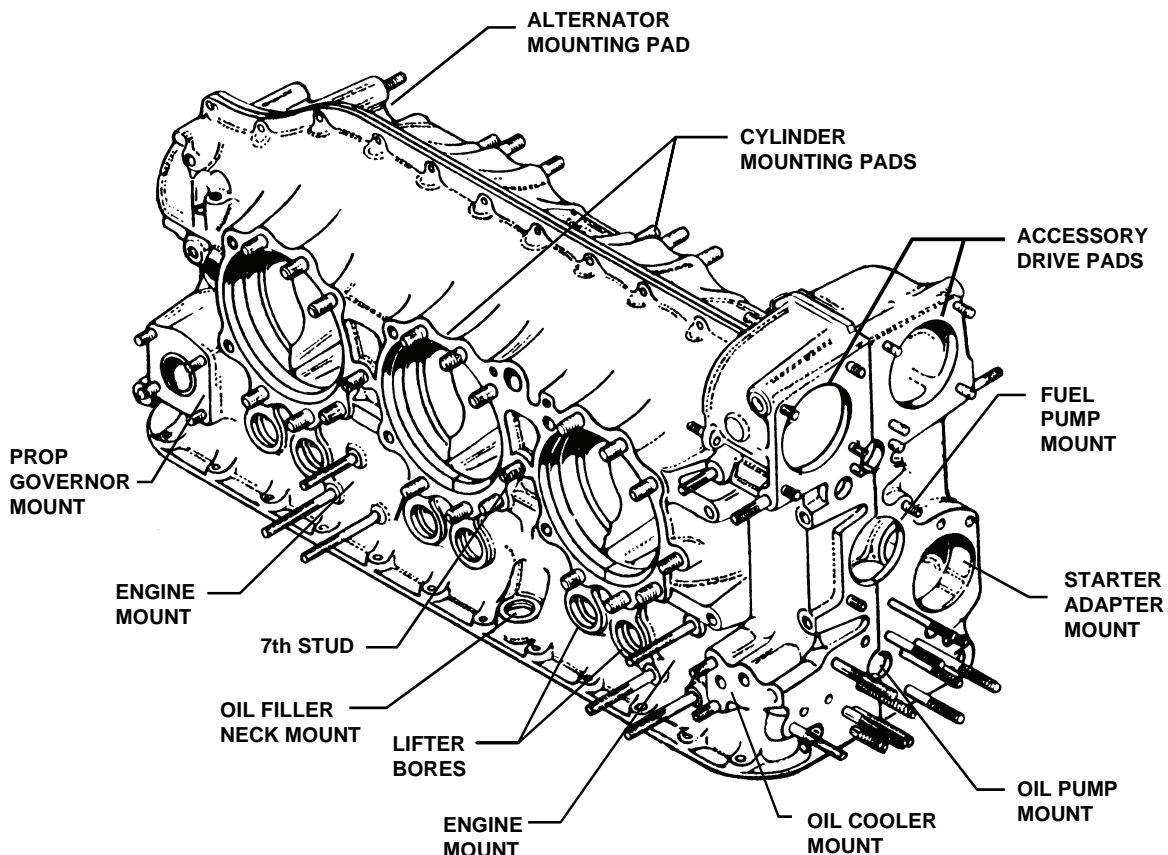

Figure 2-4. Crankcase



### 2-2.2. Engine Drive Train

When starting the engine, torque is transmitted from the starter through the starter adapter components to the crankshaft gear. As the worm gear in the adapter is turned, a spring mounted on the hub is tightened to grip the knurled drum of the shaft gear. After starting, the spring returns to its normal position releasing the shaft gear and disengaging the starter.

Torque is transmitted to the alternator by a face gear mounted on the crankshaft. Torque from the crankshaft is transmitted by the crankshaft gear directly to the idler gear and the camshaft gear. The idler gear rotates in a counter-clockwise direction to drive the magneto drive gears. Optional accessories mounted on the aft side of the accessory case are driven by the internal splines of the magneto drive gears.

The fuel pump coupling is connected directly to the crankshaft gear. The splined end of the oil pump drive gear mates with the internal splines of the camshaft gear and transmits torque to the oil pump driven gear. The governor drive bevel gear is physically attached to the end of the camshaft; it meshes with the governor driven bevel gear to provide power to the propeller governor.

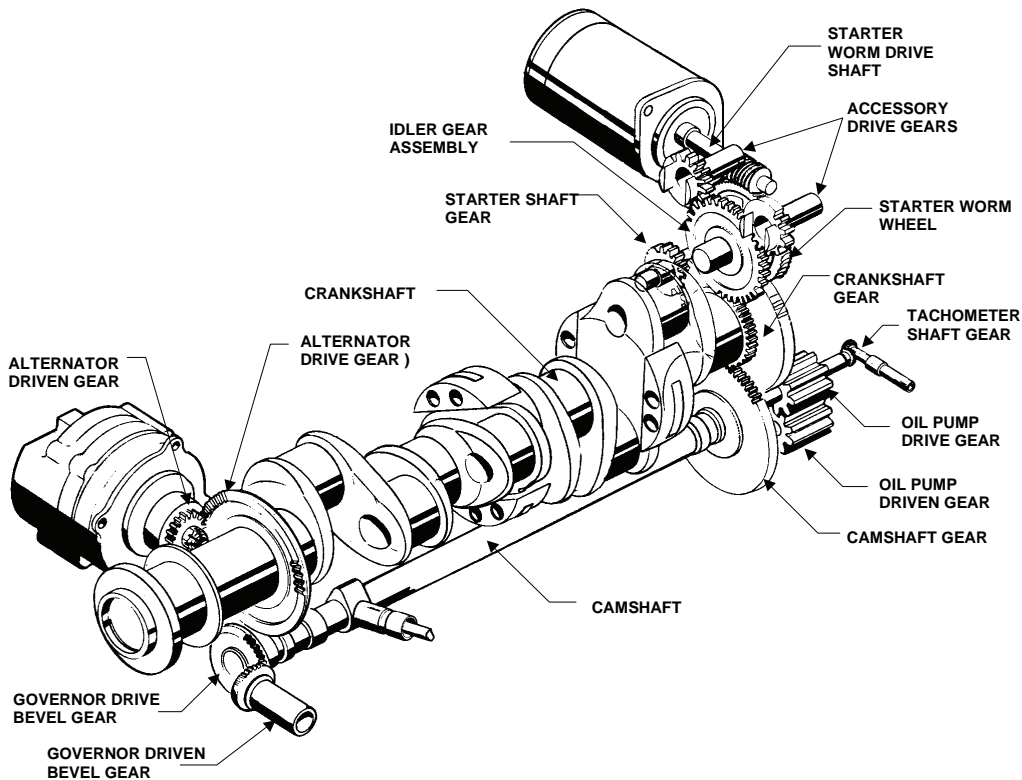

Figure 2-5. Engine Drive Train

### 2-2.2.1. Crankshaft

The crankshaft is precision machined aircraft quality steel having five main journals which rotate on bearings in the crankcase. Six rod journals are the connecting points for the connecting rod assemblies.

Counterweights are supplied in matched pairs with the bushings installed; total weight difference between pairs is not to exceed two grams. Counterweight order number designates the vibration order the counterweight is capable of absorbing. A sixth order counterweight is designed to counteract six vibrations per revolution of the crankshaft. Similarly, if a crankshaft produces five vibrations per revolution, a fifth order counterweight is used to offset the vibration. Two sixth order counterweights are installed in the number two crankshaft cheek hangers. On the two number five crankshaft cheek hangers, one fifth order and one fourth order counterweight is installed.

The crankshaft gear is heated prior to installation to obtain a shrink fit. The gear is positioned on the crankshaft by a dowel pin; it incorporates a square output coupling to direct drive fuel pump. The gear also has a machined timing mark to properly position the crankshaft and camshaft angles.

The alternator drive gear is attached by a flange just behind the number 5 main journal at the front of the crankshaft and secured by four bolts and lockplates. A neoprene oil seal, which is stretched over the crankshaft flange, and a split retainer ring are seated between the crankcase castings in the front crankshaft exit area and is sealed to the crankshaft by a helical spring inside the sea's cavity.

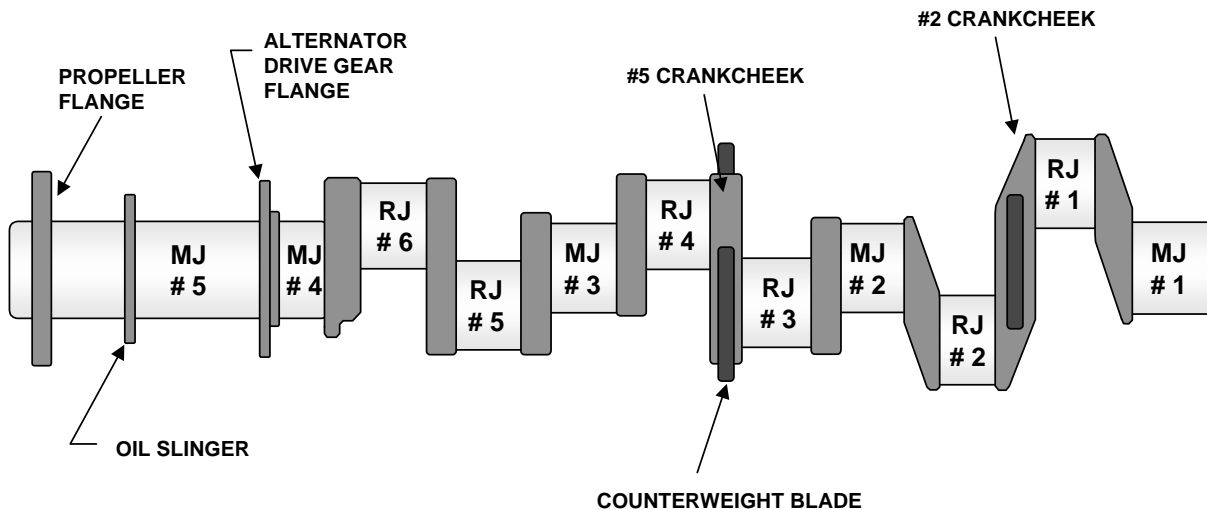

Figure 2-6. Crankshaft

### 2-2.2.2. Connecting Rods

The connecting rods halves are machined from a single forging of aircraft quality steel and cut into two pieces, splitting the center of the larger opening of the connecting rod assembly. The resulting pieces, called the rod and cap are fitted with a two piece bearing and attach to the crankpin or rod journal with special bolts and nuts.





The portion of the rod between the rod and the crankpin and piston pin ends is called the “I” beam. A split steel-backed bronze bushing is pressed into the piston pin end and machined for a precision pin-to-bushing fit. Weight variations between opposing crankshaft positions is limited to ½ ounce (14.175 grams).

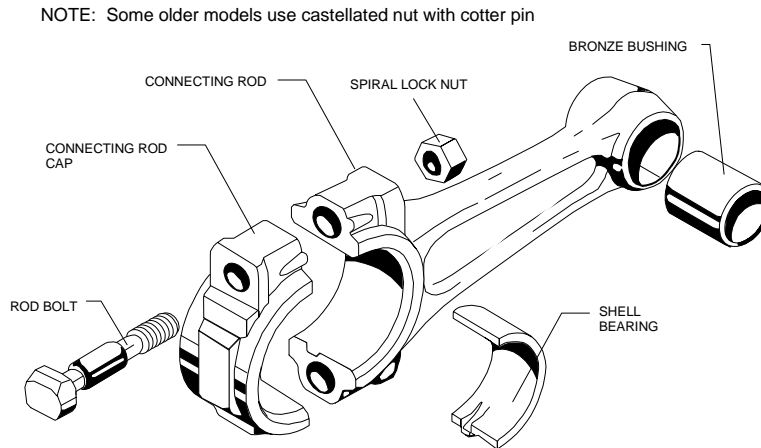

### 2-2.2.3. Camshaft

The camshaft is machined from an aircraft quality steel casting. The forging is machined on four main journals, nine cam lobes and a gear mounted flange at the rear of the camshaft. The main journals ride within the crankcase camshaft bores. The hydraulic tappet movement inward and outward in these bores is caused by the eccentric camshaft lobes. The lobes and journals are ground and hardened. Movement of the tappets opens and closes the intake and exhaust valves within the cylinder head by mechanical linkage of the pushrods and rocker arms. The exact moment of valves opening and closing is synchronized by the crankshaft to camshaft timing. Four unequally spaced bolts retaining the gear to the camshaft ensure proper positioning, locating the gears’ timing mark in relation to the cam lobes. The camshaft gear incorporates a splined drive for the engine oil pump. A front mounted keyed bevel drive gear provides momentum for the prop governor bevel driven gear.

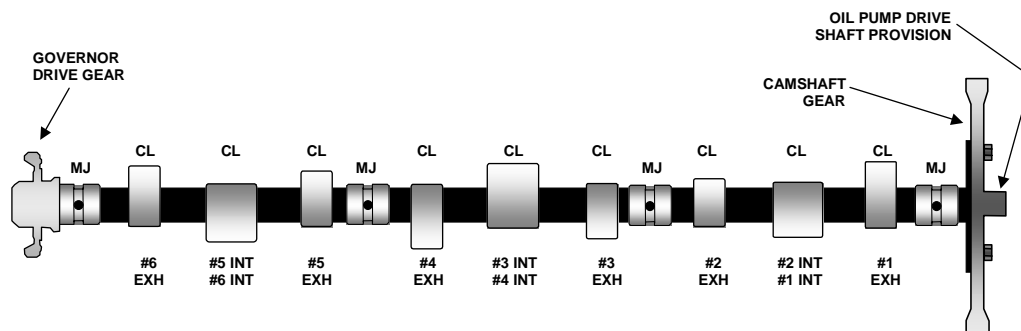

### 2-2.2.4. Idler Gear

The idler gear support pin supports the idler gear. The bushing in the crankcase supports the forward part of the idler gear support pin shaft. The crankshaft drives the idler gear directly. In turn, the idler gear drives the left and right magneto accessory drive gears.



### 2-2.3. Cylinders

The TSIO-550 Permold Series engines have six, horizontally-opposed, air cooled cylinders, three on the left side and three on the right side of the engine. The cylinders, pistons and valve drive train provide the momentum to sustain crankshaft movement. Aviation fuel and air are drawn into a cylinder during the intake stroke, compressed by the piston during the compression stroke and then ignited by a high intensity spark from each spark plug (two per cylinder). As the mixture is ignited, the expanding gases force the piston to move inward toward the crankshaft during the power stroke.

The head and barrel assembly consists of externally finned aluminum alloy head casting and a steel, nitrided cylinder barrel for wear resistance. Helical coil thread inserts are installed in upper and lower spark plugs holes. A rotocoil assembly retains two concentric springs surrounding the exhaust valve and is locked to the stem by tapered, semi-circular keys which engage grooves around the valve stems. An outer retainer holds two concentric springs which surround the intake valve and is locked to the stem by tapered, semi-circular keys which engage grooves on the stem.

TSIO-550 B, C, E and G Permold Series engines use a cross flow cylinder head design. The intake ports are located on top of the cylinder head while the exhaust ports are located below. Separate intake and exhaust valve rocker covers are stamped from zinc-plated sheet steel. This cylinder design is used in conjunction with a Balanced Induction System mounted above the engine.

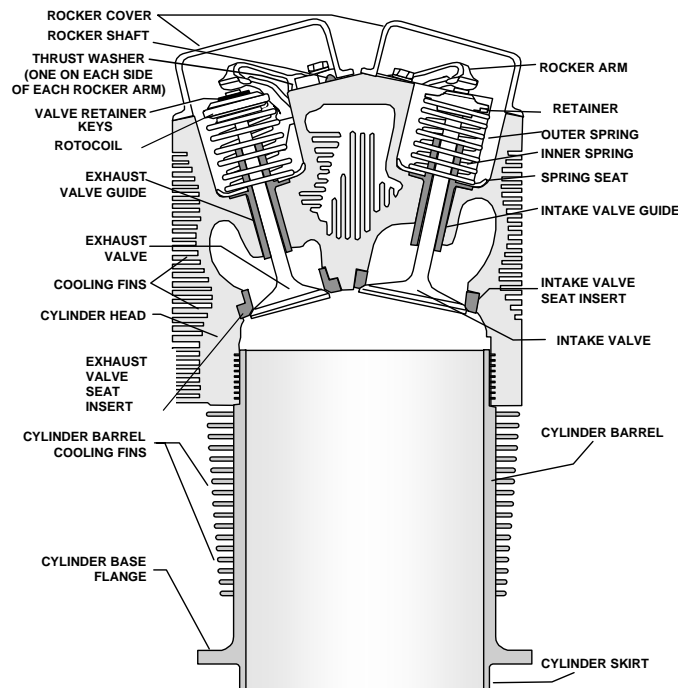
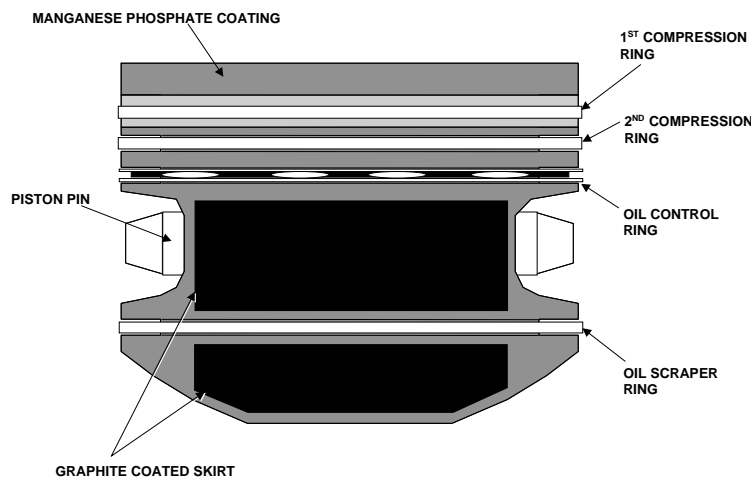

Figure 2-7. Cylinder Assembly



### 2-2.3.2. Pistons

Pistons are aluminum alloy castings with a steel insert cast into the top ring groove. The skirts are solid with cylindrical relief cuts at the bottom. Pistons have three ring grooves above the piston pin hole and one ring groove below. Compression rings are installed in the top and second grooves. The groove below the pin hole contains an oil scraper. A center grooved and slotted oil control ring is installed in the third groove which has six oil drain holes to the interior. Weight differences are limited to ½ ounce between opposing cylinders bays. Piston pins are full floating with permanently pressed-in aluminum end plugs.



### 2-2.3.3. Hydraulic Valve Tappets

The hydraulic lifter performs two functions. First, it provides an interface between the camshaft lobe and the remaining valve train. Hydraulic valve lifters ride on the eccentric cam lobes, opening and closing the intake and exhaust valves mechanically via push rod tubes and rocker arms. This allows conversion of the cam lobe profile into a linear movement for actuation of the intake and exhaust valves. Secondly, the hydraulic mechanism inside the lifter maintains zero clearance between the valve and its actuating components.

The interface between a cam lobe and lifter is intended to wear to some degree as the engine operates. This is similar to the piston ring / cylinder wall interface that must seat together for proper operation and wear over time.

### 2-2.4. Lubrication System

The lubrication system reduces friction between moving parts in the engine. The engine oil supply is contained in the oil sump. The oil is drawn from the sump through the oil suction screen and tube to the intake side of the oil pump. From the outlet side of the pump, oil is directed to the oil pressure relief valve, and on to the full flow, replaceable oil filter. A bypass valve is incorporated in the oil filter. From the oil filter discharge port, oil is directed through a crankcase passage to the oil cooler.

Oil entering the engine is directed to the hollow camshaft which serves as the engine main oil gallery. Oil leaving the camshaft interior at the front of the crankcase is directed to the left main crankcase gallery. From there, oil is directed upward through the

crankcase oil passages to the main thrust bearing, the governor drive gear, and accessory pad. From the governor drive gear, lubricating oil is directed from the left main gallery through the propeller governor to the drilled crankcase passages and oil transfer collar to the crankshaft. Oil then travels through a transfer plug installed in the inside diameter of the crankshaft and is routed to the variable pitch propeller. Hydraulic valve tappets transfer oil from the main oil galleries to the cylinder overhead through the hollow pushrods to a drilled oil passage in the rocker arms. Oil exiting the rocker arms lubricates the valve, rocker shaft arm, stems, springs and rotocoils. The oil then falls to the lower rocker cavity and returns to the crankcase and sump through the pushrod housings.

Oil from the left main crankcase gallery is also directed upward through crankcase oil passages to the crankshaft main bearings and idler gear bushing. Oil is directed upward from the idler gear bushing to both accessory drive bushings. Oil lubricating the crankshaft mains is directed through the upper main bearing oil holes, through crankcase passages to oil squirt nozzles that spray oil onto the underside of the pistons. Oil falls from the pistons through the crankcase cavity back to the oil sump.

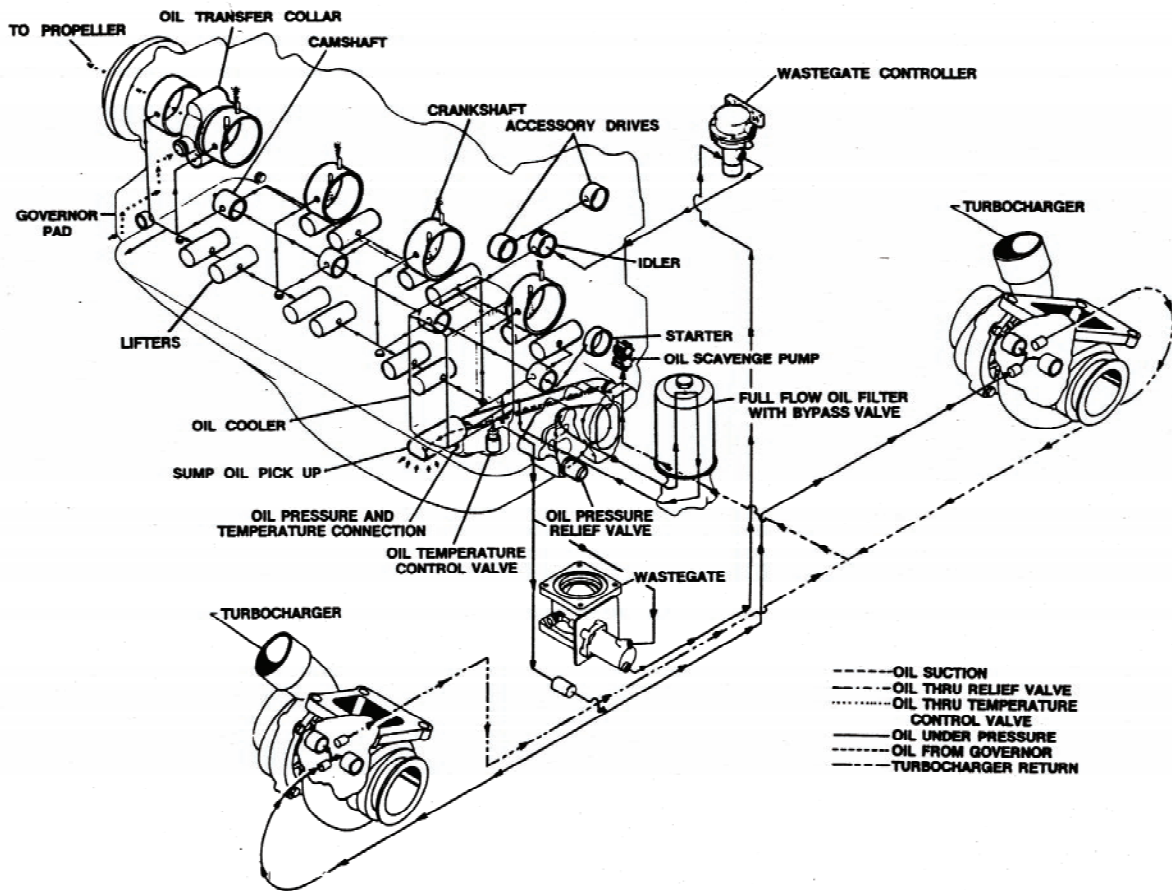

Figure 2-8. Lubrication Schematic



### 2-2.4.2. Oil Pump

The positive displacement oil pump consists of two meshed gears that revolve inside the pump housing cavity.

The camshaft drives the oil pump drive gear. The oil pump drive gear drives the oil pump driven gear. The oil pump driven gear is supported by a shaft pressed into the oil pump housing. The oil pump drive gear shaft is supported by the tach drive housing on one end and the oil pump housing at the opposite end. The oil pump drive gear has a tachometer drive gear attached to its end which drives a tachometer shaft gear inside the tach drive housing for either electrical or mechanical tachometers.

As the engine starts rotating, the oil pump drive gear turns counterclockwise (viewed from rear of engine). The drive gear meshes with the driven gear to turn it clockwise. The rotating gears create a suction that draws oil from the sump through the oil suction tube to the pump gear inlet.

Oil flows from the oil pump to the oil filter housing and filter element. The oil is then directed through the element, down through a passage in the oil pump housing and out to the right crankcase main oil gallery. A by-pass is installed in the oil pump housing to allow an alternate route for oil passage in the event the oil filter element becomes clogged. The adjustable oil pressure relief valve limits oil pressure to a predetermined value. This ensures adequate lubrication to the engine and its accessories at high engine RPM. Oil pressure is adjusted by turning the oil pressure relief valve adjusting screw.

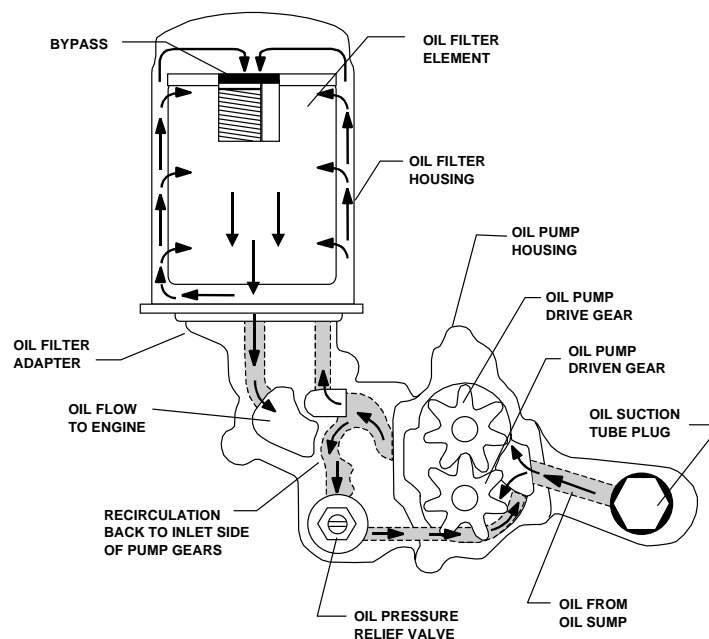

Figure 2-9. Oil Pump

### 2-2.4.3. Oil Sumps

The sump is held to the crankcase sump mount flange with bolts, washers, and lock washers. The oil sump assembly incorporates a tapped drain plug boss and a plug and

crush washer to facilitate draining engine oil. The drain plug boss has provisions for safety wiring the oil drain plug after it has been properly torqued.

The oil suction tube extends from the oil sump to the oil pump inlet boss providing oil pickup and flow path. The opposite end of the pickup tube on all models has a crush washer installed on the end of the suction tube. This tube protrudes through the crankcase and is bolted to the crankcase oil pump inlet.

#### 2-2.4.4. Oil Cooler and Oil Temperature Control Valve

Oil flowing from the oil pump enters the oil cooler inlet where it is directed upward to the cooler core by the cast oil gallery. When the oil is below normal operating temperature the oil temperature control valve (vernatherm) is open allowing oil to flow through the center by-pass portion of the oil cooler.

When oil temperature reaches 180°F the oil temperature control valve expands blocking oil flow. Oil flow is then re-directed through the oil cooler core. As the oil flows through the cooler core, cooling air fins between the core oil passages dissipate excess heat from the oil maintaining normal operational oil temperatures. Oil then flows from the cooler out to the camshaft and crankshaft left main oil gallery.

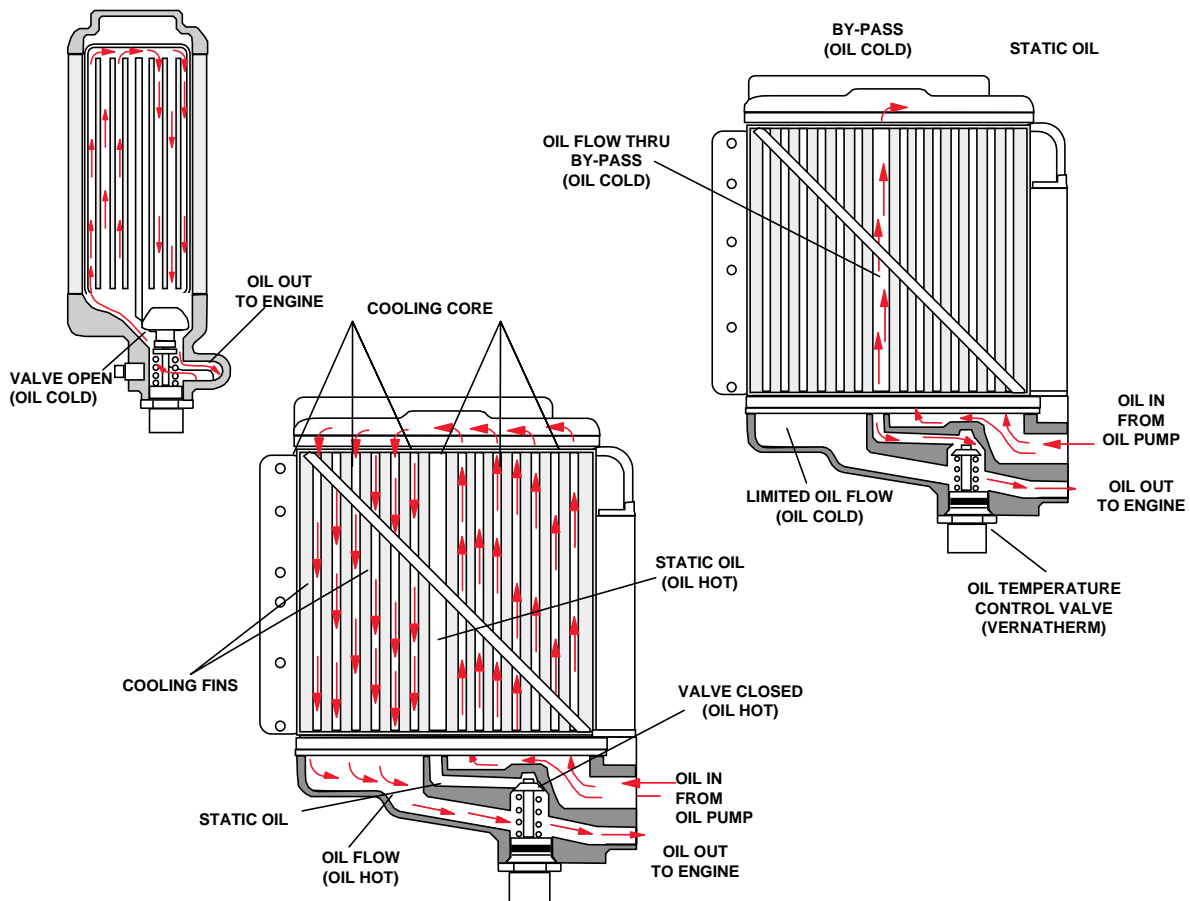

Figure 2-10. Oil Cooler

### 2-2.4.5. Turbocharger Lubrication

The lubrication system provides engine oil to the turbocharger for lubrication. Pressurized oil flows from a tee fitting on the front of the oil pump to both turbine oil reservoirs through hoses. A check valve prevents oil in the lines from leaking back in to the turbocharger reservoirs from the oil cooler when the engine is shut down. A scavenge pump on the front of the starter adapter applies negative pressure (vacuum) to the turbine oil reservoirs to boost return of the engine oil to the crankcase.

Pressurized oil flows from a separate fitting on the oil cooler to the wastegate and on to the wastegate controller which hydraulically controls the wastegate state based on the difference between upper deck and manifold pressure. Oil returns to the crankcase through a fitting in the accessory case.

### 2-2.5. Fuel System

The Fuel Delivery System is composed of an engine-driven fuel pump, a fuel distribution block, an induction system throttle body and fuel injector assemblies. The fuel injection system is a multi-port, continuous flow type which controls fuel flow to match engine requirements. The fuel metering unit/air throttle controls the amount of intake air admitted through the intake manifold and meters the proportionate amount of fuel to the fuel manifold valve.

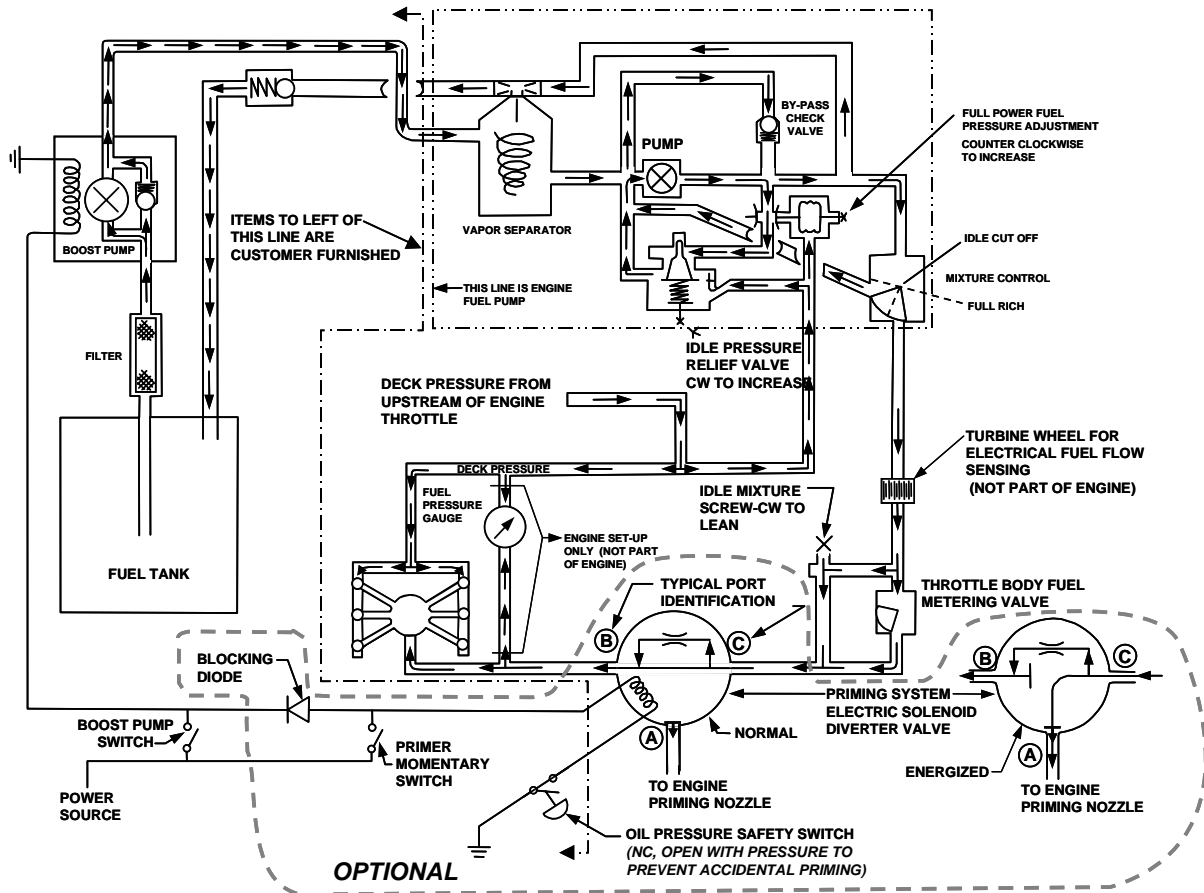

Figure 2-11. Fuel System Schematic

### 2-2.5.2. Fuel Pump

Fuel enters the fuel pump at the top of the vapor separator swirl chamber where it is centrifuged, separating the liquid from any fuel vapors. The liquid fuel is directed to the fuel pump inlet vanes. The fuel pump vanes create the necessary differential pressure required to draw fuel into the pump inlet and expel pressurized fuel from the pump outlet. Fuel vapor is separated in the swirl chamber and is returned to the aircraft's fuel tank. Fuel leaving the fuel outlet is directed through various fittings and fuel lines to the fuel distribution block and fuel injector nozzles.

In a positive displacement, engine-driven pump, changes in engine speed affect pump flow and pressure proportionally. The fuel pump is sized to provide greater capacity than is required by the engine. An integral aneroid valve functions to increase pump output pressure during high manifold pressure operation. This combination of mechanical control circuits ensures proper pump pressure and fuel delivery for all engine operating speeds.

A check valve is provided to allow the aircraft boost pump pressure to bypass the engine driven fuel pump during engine priming and starting. The check valve also permits the use of an aircraft auxiliary fuel boost pump.

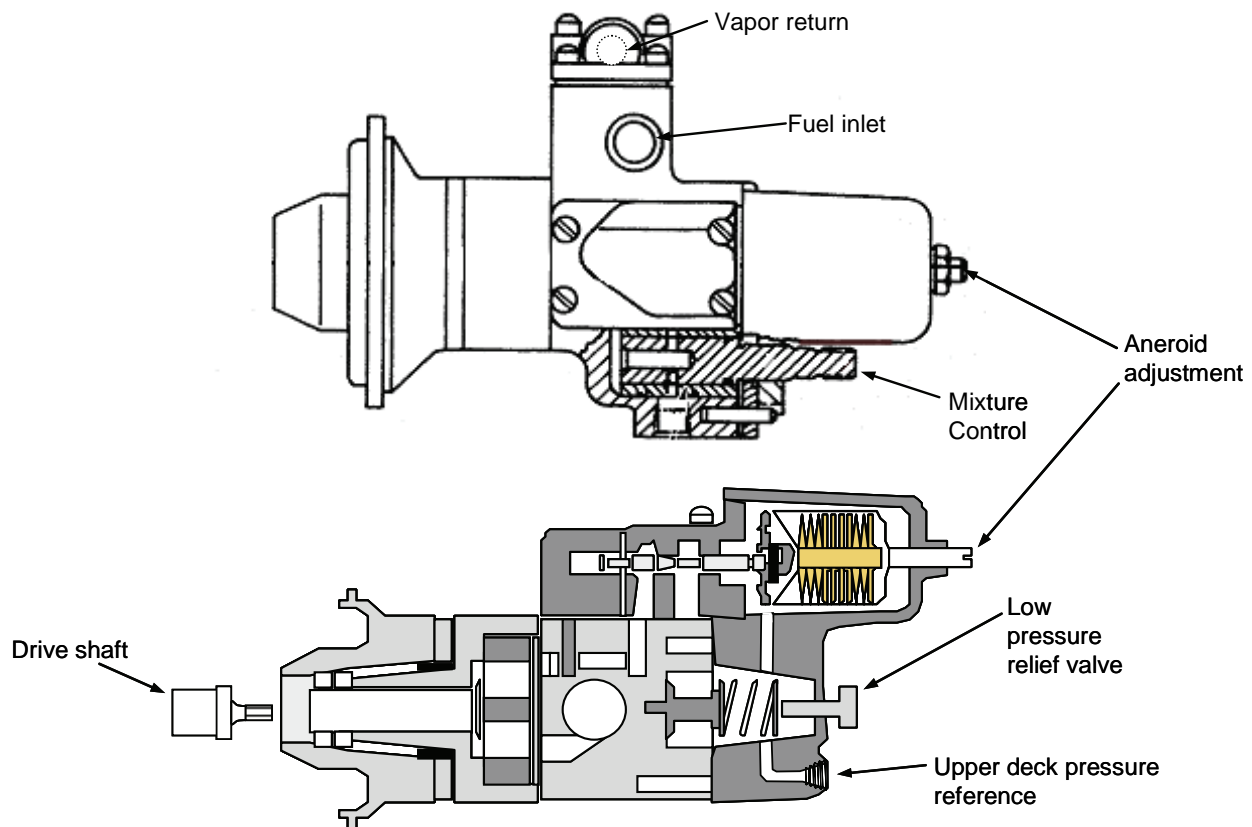

**Figure 2-12. Fuel Pump**





### **2-2.5.3. Fuel Injectors**

The fuel injectors are a constant flow design. The fuel pump delivers fuel to the manifold where the liquid is divided into equal amounts for delivery to the individual cylinder injectors. The fuel injectors are calibrated to work as a set, compensating for variations in distance from the manifold, resulting in each cylinder matching the performance of the other five for consistent, balanced operation. Each injector atomizes the fuel into the intake port of the cylinder. Fuel will enter the cylinder each time the intake valve opens.

## 2-2.6. Starter Assembly

The Starting System consists of an electric starter motor mounted on a right angle starter drive adapter. When the starter motor is electrically energized, the adapter worm shaft and gear engage the starter shaftgear through a spring and clutch assembly by turning the starter worm wheel.

As the shaftgear turns, it rotates the crankshaft gear and crankshaft. When the engine starts, electrical energy is removed from the starter motor. The gripping action of the clutch spring is relieved, disengaging the shaftgear from the worm shaft and electric starter motor. The starter shaftgear extends from the rear of the starter adapter.

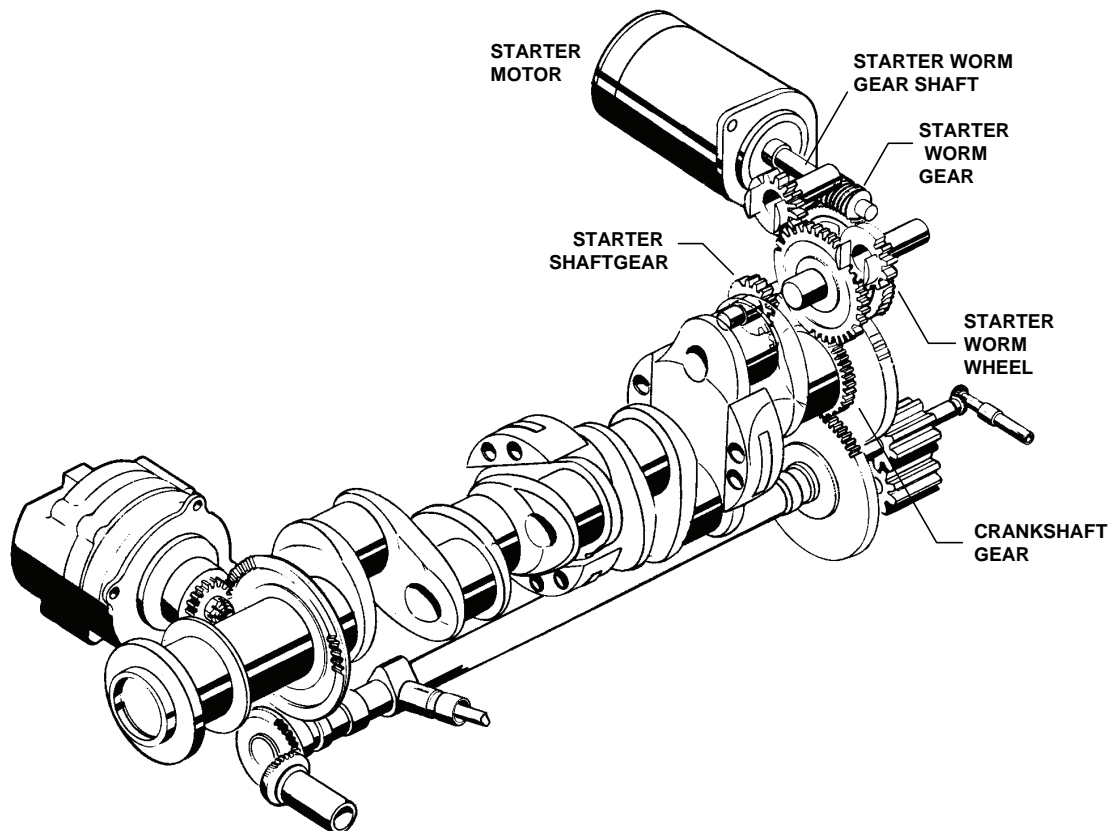

Figure 2-13. Starting System

## 2-2.7. Alternator

A gear-driven alternator is mounted on the right front crankcase half. The alternator generates electrical current for recharging aircraft batteries and powering the electrical system of the aircraft. TCM alternators are available in multiple voltage output options to match aircraft circuit requirements.



### 2-2.8. Ignition System

TSIO-550 Permold Series engines ignition systems use either TCM (Bendix) or Unison (Slick) pressurized magnetos in a dual configuration for redundant ignition to each cylinder. Dual spark plugs are installed in bosses in each cylinder head. Magneto pressurization is provided by engine deck pressure.

Magnetos are installed in magneto and accessory drive adapters on the rear of the engine and driven by the crankshaft. The magnetos employ impulse couplings, which rotate faster than the engine cranking speed, automatically retarding the spark during engine cranking for easier starting.

Magnetos are fitted with a tachometer pickup sensor installed in the flange housing vent.

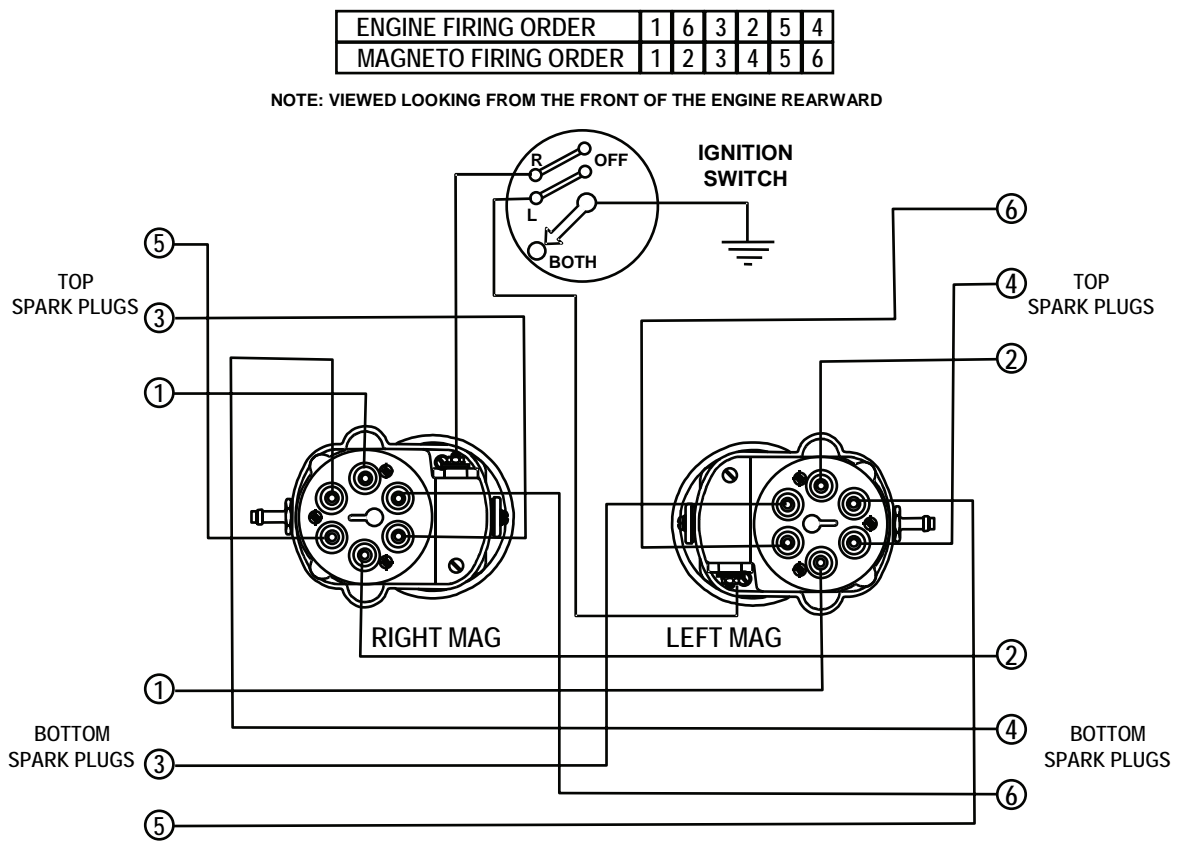

Figure 2-14. Ignition System Schematic

## 2-2.9. Engine Cooling

The engine cylinders are cooled by transferring heat from the cylinder barrel and cylinder head cooling fins to the surrounding airflow. The airframe engine cowl, baffles, and baffle seals direct cooling air (which is ram air-induced by the aircraft's forward speed) evenly around the cylinders. This airflow is regulated by the size of the cooling air inlets and outlets. Increasing or decreasing outlet size with the use of cowl flaps changes airflow and is used as an aid in controlling engine operating temperatures.

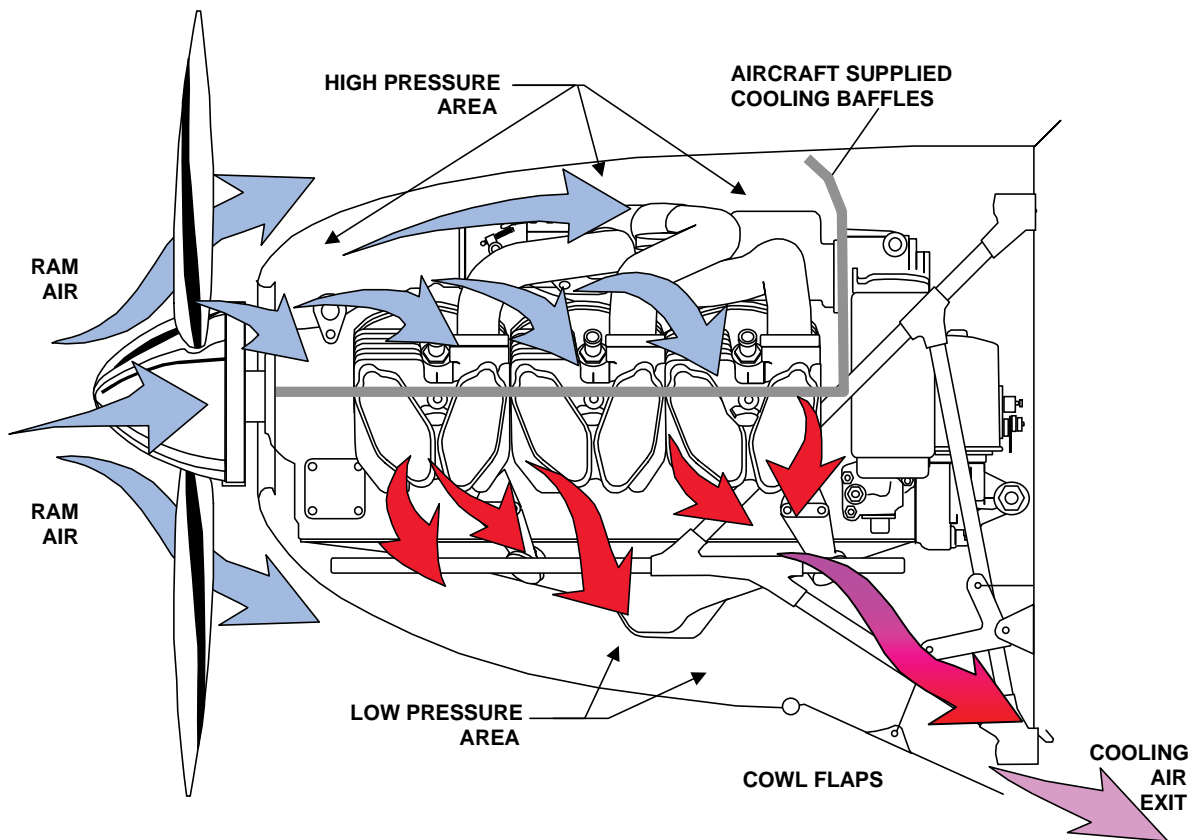

Figure 2-15. Engine Cooling Airflow

## 2-2.10. Induction System

The Induction System carries induction air to individual cylinder intake ports through a cross flow cylinder head design. A downdraft-type Induction System is mounted on the top of the cylinder heads, with a balanced intake manifold mounted above the engine crankcase which carries induction air to the individual cylinder intake distribution ports via cylinder induction tubes.

Air from the balanced induction manifold is carried to the intake ports where it mixes with fuel from the injector nozzles. The fuel/air charge then enters the cylinder as a combustible mixture when the intake valve opens.

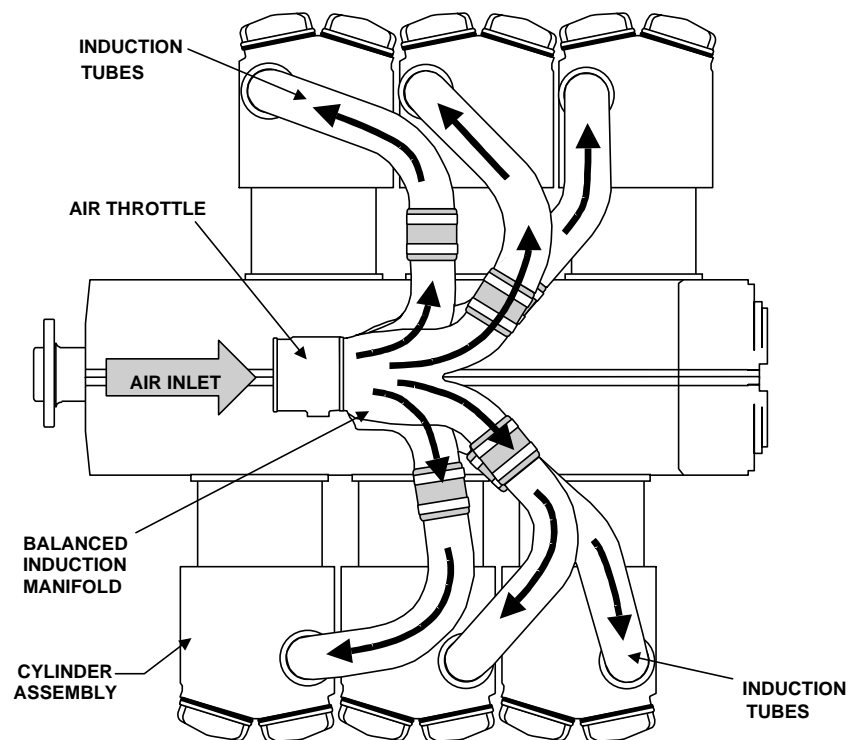

Figure 2-16. Typical Crossflow Induction Airflow

## 2-2.11. Turbocharger and Exhaust

NOTE: TSIO-550-G aftercoolers and exhaust differ dimensionally from the other Permold engines but the function of the turbocharger system is the same as the other engines in the TSIO-550 Permold series.

The turbocharger system contains the following engine components: two turbochargers, aftercooler, hydraulic controlled exhaust by-pass (wastegate), wastegate controller, lubrication plumbing, exhaust collector assembly, and turbocharger tailpipe assembly. Special lines and fittings are also attached to the upper-deck pressure for air reference to the fuel injection system and magneto pressurization.

Exhaust gases exit the cylinder combustion chambers and flow through the exhaust collector to the turbocharger turbine housing inlet. The exhaust gas flow provides turbine

wheel rotation and exits through the turbine housing discharge port and tailpipe assembly. The turbine wheel drives the compressor wheel which is connected by a common shaft.

Engine manifold pressure is maintained within the specified limits by controlling the turbocharger compressor discharge pressure. Compressor discharge pressure (deck pressure) is regulated by controlling the flow of exhaust gas through the turbocharger turbine.

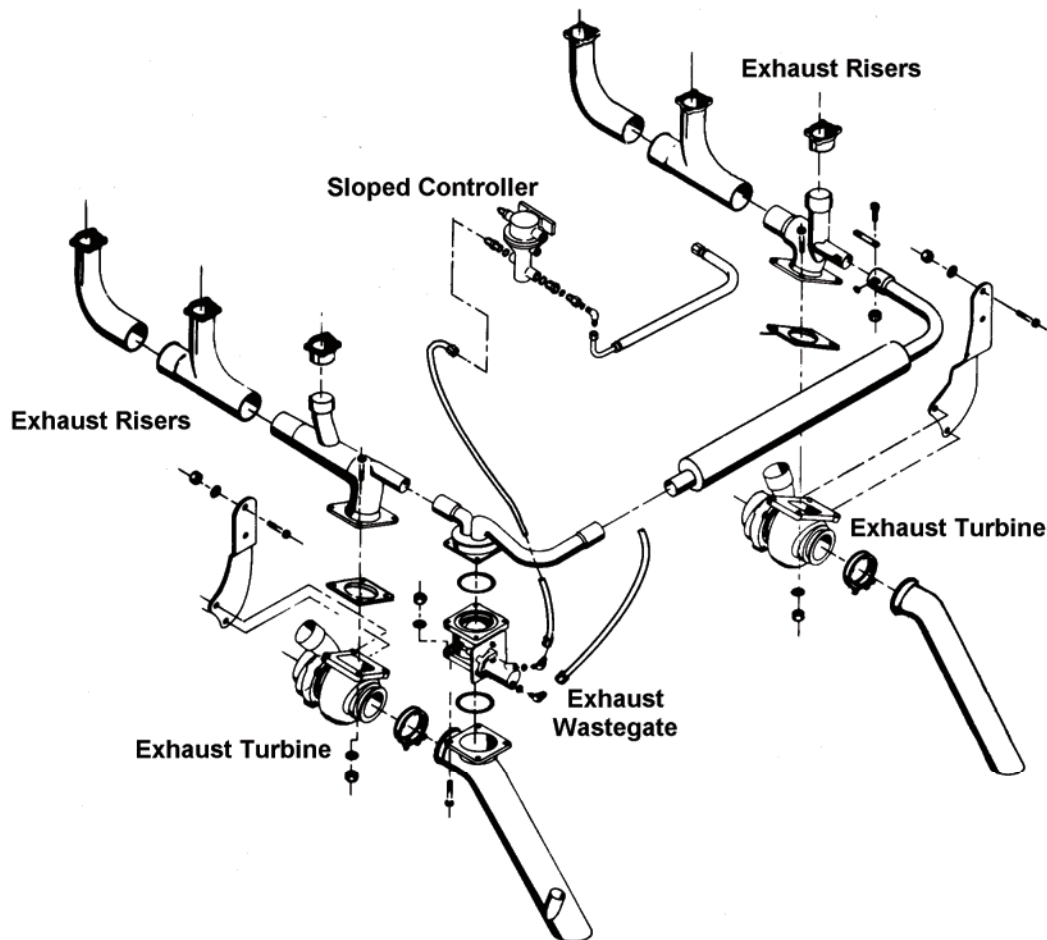

Figure 2-17. Turbocharger and Exhaust

### 2-3. Engine Specifications and Operating Limits

TSIO-550 B, C, E, and G Permold Series engine model specifications and operating limits are presented in separate tables in the following pages:



2-3.1. TSIO-550-B Specifications and Operating Limits

| Table 2-1. TSIO-550-B Specifications & Operating Limits   |  |               |
|---|--|---------------|
| General   |  |               |
| Model   | TSIO-550-B   |               |
| FAA Type Certificate  | E5SO   |               |
| Installation Drawing Number   | 653021   |               |
| Arrangement   | Individual cylinders horizontally opposed  |               |
| Compression Ratio   | 7.5:1  |               |
| Number of Cylinders   | 6  |               |
| Firing Order  | 1-6-3-2-5-4  |               |
| Time Between Overhaul (TBO)   | 1600 accumulated operating hours or 12 years   |               |
| Bore  | 5.25 inches  | 13.335 cm     |
| Stroke  | 4.25 inches  | 10.795 cm     |
| Piston Displacement   | 552 cubic inches   | 9.05 L        |
| Crankshaft Speed & Brake Horsepower   |  |               |
| Rated Maximum Continuous Operation*   | 350 bhp -0%+5% @ 2700 rpm  |               |
| Crankshaft Speed (Maximum rated)  | 2700 rpm   |               |
| Engine Idle Speed, Minimum  | 600 +/- 25 rpm   |               |
| Rated Manifold Pressure   | 38.0 in. Hg Full Throttle (Sea Level)  |               |
| Maximum Recommended Cruise  | 262 bhp @ 2500 rpm   |               |
| * Performance is based on sea level, standard day, zero water vapor pressure conditions at the throttle inlet and exhaust exit with no engine accessory load. Standard day conditions are 29.92 in Hg and 59° F. Horsepower will vary approximately 1% for each 6° F (5.6° C) change in compressor inlet air temperature. Correction must also be made for the effect of exhaust backpressure and accessory drive losses. Contact TCM engineering for correction factors for specific applications. |  |               |
| Fuel System Specifications  |  |               |
| Fuel Control System   | TCM Continuous Flow Fuel Injection   |               |
| Fuel Minimum Grade**  | 100LL Blue or 100 Green  |               |
| Russian Commonwealth of Independent States  | B95/130  |               |
| People's Republic of China  | RH95/130***  |               |
| Fuel System Pressure & Flow   | Refer to Chapter 5, "Engine Operational Check"   |               |
| Boost Fuel Pump Specifications  | Refer to TCM's Detailed Model Specifications   |               |
| ** Engine is certified for operation with 100-LL Blue or 100 Green aviation fuel. If the minimum fuel grade is not available, use the next higher grade available; never use a lower grade fuel.  |  |               |
| *** Engine operation with this fuel is limited to 9840 ft (2999 m) at maximum continuous power and speed and 19680 feet (5998 m) at maximum recommended cruise power and speed.   |  |               |
| Fuel Consumption  |  |               |
| Power Level   | BHP (kW)   | lbs./hr (max) |
| Rated Power, 100%   | 350 (261)  | 255           |
| Cruise, 75%   | 263 (196)  | 157           |
| Cruise, 65%   | 228 (170)  | 125           |
| Cruise, 55%   | 193 (138)  | 108           |
| Ignition  |  |               |
| Spark Plugs to be used  | Refer to TCM's Service Information Letter SIL 03-2A "Currently Active Approved Spark Plug Application" |               |
| Ignition Timing   | 24°BTC±1°  |               |
| Spark Plug Gap  | Spark plug manufacturer's specified gap.   |               |



| Table 2-1. TSIO-550-B Specifications & Operating Limits   |  |             |
|---|--|-------------|
| <b>Cylinder Head Temperature (measured with bayonet thermocouple)</b>                           |  |             |
| Normal Operational Temperature (cruise)   | 380°F  | 193°C       |
| Maximum Allowable Operational Temperature   | 460°F  | 238°C       |
| Minimum Take-off Temperature  | 240°F  | 116°C       |
| *All temperatures are measured with bayonet thermocouples.                                      |  |             |
| <b>Exhaust</b>  |  |             |
| Exhaust System back-pressure, maximum, measured at port, inches Hg (kPa)                        | 2.5 (8.5)                                    |             |
| EGT Thermocouple Probe, min. location distance from port, in (mm)                               | 2.00/2.50 (50.8/63.5)                        |             |
| <b>Oil</b>  |  |             |
| Oil Pressure – Normal Operation @ 100°F to 240°F (38 to 116°C)*                                 | 30 to 60 psig                                |             |
| Maximum Allowable Oil Pressure* (cold oil)  | 100 psig                                     |             |
| Minimum Oil Pressure @ Idle (600 RPM)*  | 10 psig at or below 200°F                    |             |
| Maximum Allowable Oil Temperature*  | 240°F  | 116°C       |
| Minimum Take-off Oil Temperature*   | 100°F  | 38°C        |
| Cruise Flight Operation Oil Temperature   | 160° to 180°F                                | 71° to 82°C |
| Oil Sump Capacity   | 12.0 Quarts                                  |             |
| Useable Oil - 20° Nose Up (12 quart fill)   | 7.5 Quarts                                   |             |
| Useable Oil – 14.5° Nose Down (12 quart fill)   | 6.5 Quarts                                   |             |
| Recommended Oil Grade, SAE – above 40°F   | 50 or Multi Viscosity                        |             |
| Recommended Oil Grade, SAE – below 40°F   | 30 or Multi Viscosity                        |             |
| Oil Grade, TCM Specification  | MHS-24                                       |             |
| CAUTION: Oil must be aviation oil conforming to MHS-24.   |  |             |
| *Oil pressure and temperature are measured at the oil cooler adapter.                           |  |             |
| <b>Brake Specific Oil Consumption (BSOC)</b>  |  |             |
| Maximum BSOC = .006 lb/HP/HR x (%Power/100)   |  |             |
| <b>Engine Physical Specifications</b>   |  |             |
| Weight, dry (minimum runnable engine), lb. (kg) +/- 2.5%  | 447.1 (202.8)                                |             |
| Detailed weights by Specification Number  | Refer to TCM's Detailed Model Specifications |             |
| Overall Dimensions, inches (mm)   |  |             |
| Height  | 32.7   | (830.6)     |
| Width   | 42.2   | (1071.9)    |
| Length  | 40.75  | (1035.0)    |
| Center of Gravity, inches (mm)  |  |             |
| Forward of rear accessory case  | 12.66  | (322)       |
| Below crankshaft centerline   | 1.30   | (33)        |
| Beside crankshaft centerline toward 1-3-5 side  | 0.12   | (3)         |
| Moment of Inertia, standard accessory package, in-lb·sec <sup>2</sup> (mm·kg·sec <sup>2</sup> ) |  |             |
| Roll - Longitudinal Axis, (I <sub>x-x</sub> )   | 83   | (956)       |
| Pitch - Lateral Axis, (I <sub>y-y</sub> )   | 105  | (1210)      |
| Yaw - Vertical Axis, (I <sub>z-z</sub> )  | 172  | (1982)      |





2-3.2. TSIO-550-C Specifications and Operating Limits

| Table 2-2. TSIO-550-C Specifications & Operating Limits   |  |               |
|---|--|---------------|
| <b>Cylinders</b>  |  |               |
| Model   | TSIO-550-C   |               |
| FAA Type Certificate  | E5SO   |               |
| Installation Drawing Number   | 646618   |               |
| Arrangement   | Individual cylinders horizontally opposed  |               |
| Compression Ratio   | 7.5:1  |               |
| Number of Cylinders   | 6  |               |
| Firing Order  | 1-6-3-2-5-4  |               |
| Time Between Overhaul   | 2000 accumulated operating hours or 12 years   |               |
| Bore  | 5.25 inches  | 13.335 cm     |
| Stroke  | 4.25 inches  | 10.795 cm     |
| Piston Displacement   | 552 cubic inches   | 9.05 L        |
| <b>Crankshaft Speed &amp; Brake Horsepower</b>  |  |               |
| Rated Maximum Continuous Operation*   | 310 bhp -0%+5% @ 2600 rpm  |               |
| Crankshaft Speed (Maximum rated)  | 2600 rpm   |               |
| Engine Idle Speed, Minimum  | 600 rpm  |               |
| Rated Manifold Pressure   | 35.5 in. Hg Full Throttle (Sea Level)  |               |
| Maximum Recommended Cruise  | 262 bhp @ 2550 rpm   |               |
| * Performance is based on sea level, standard day, zero water vapor pressure conditions at the throttle inlet and exhaust exit with no engine accessory load. Standard day conditions are 29.92 in Hg and 59° F. Horsepower will vary approximately 1% for each 6° F (5.6° C) change in throttle inlet air temperature. Correction must also be made for the effect of exhaust backpressure and accessory drive losses. Contact TCM engineering for correction factors for specific applications. |  |               |
| <b>Fuel System Specifications</b>   |  |               |
| Fuel Control System   | TCM Continuous Flow Fuel Injection   |               |
| Fuel Minimum Grade**  | 100LL Blue or 100 Green  |               |
| Russian Commonwealth of Independent States  | B95/130  |               |
| People's Republic of China  | RH95/130***  |               |
| Fuel System Pressure & Flow   | Refer to Chapter 5, "Engine Operational Check"   |               |
| Boost Fuel Pump Specifications  | Refer to TCM's Detailed Model Specifications   |               |
| ** Engine is certified for operation with 100-LL Blue or 100 Green aviation fuel. If the minimum fuel grade is not available, use the next higher grade available; never use a lower grade fuel.  |  |               |
| *** Engine operation with this fuel is limited to 9840 ft (2999 m) at maximum continuous power and speed and 19680 feet (5998 m) at maximum recommended cruise power and speed.   |  |               |
| <b>Fuel Consumption</b>   |  |               |
| Power Level   | BHP (kW)   | lbs./hr (max) |
| Rated Power, 100%   | 310 (231)  | 224           |
| Cruise, 85%   | 264 (197)  | 162           |
| Cruise, 75%   | 233 (174)  | 143           |
| Cruise, 65%   | 202 (150)  | 126           |
| <b>IGNITION</b>   |  |               |
| Spark Plugs to be used  | Refer to TCM's Service Information Letter SIL 03-2A "Currently Active Approved Spark Plug Application" |               |
| Ignition Timing   | 24°BTC±1°  |               |
| Spark Plug Gap  | Spark plug manufacturer's specified gap.   |               |



| Table 2-2. TSIO-550-C Specifications & Operating Limits  |  |             |
|--|--|-------------|
| <b>Cylinder Head Temperature (measured with bayonet thermocouple)</b>                              |  |             |
| Normal Operational Temperature (cruise)  | 420°F  | 216°C       |
| Maximum Allowable Operational Temperature  | 460°F  | 238°C       |
| Minimum Take-off Temperature   | 240°F  | 116°C       |
| *All temperatures are measured with bayonet thermocouples.   |  |             |
| <b>Exhaust</b>   |  |             |
| Exhaust System back-pressure, maximum, measured at port, inches Hg (kPa)                           | 2.5 (8.5)                                    |             |
| EGT Thermocouple Probe, min. location distance from port, in (mm)                                  | 2.00/2.50 (50.8/63.5)                        |             |
| <b>Oil</b>   |  |             |
| Oil Pressure – Normal Operation @ 100°F to 240°F (38 to 116°C)*                                    | 30 to 60 psig                                |             |
| Maximum Allowable Oil Pressure* (cold oil)   | 100 psig                                     |             |
| Minimum Oil Pressure @ Idle (600 RPM)*   | 10 psig at or below 200°F                    |             |
| Maximum Allowable Oil Temperature*   | 240°F  | 116°C       |
| Minimum Take-off Oil Temperature*  | 100°F  | 38°C        |
| Cruise Flight Operation Oil Temperature  | 170° to 200°F                                | 77° to 93°C |
| Oil Sump Capacity  | 8.0 Quarts                                   |             |
| Useable Oil - 16° Nose Up (8 quart fill)   | 5.0 Quarts                                   |             |
| Useable Oil – 10° Nose Down (8 quart fill)   | 4.5 Quarts                                   |             |
| Recommended Oil Grade, SAE – above 40°F  | 50 or Multi Viscosity                        |             |
| Recommended Oil Grade, SAE – below 40°F  | 30 or Multi Viscosity                        |             |
| Oil Grade, TCM Specification   | MHS-24                                       |             |
| CAUTION: Oil must be aviation oil conforming to MHS-24.  |  |             |
| *Oil pressure and temperature are measured at the oil cooler adapter.                              |  |             |
| <b>Brake Specific Oil Consumption (BSOC)</b>   |  |             |
| Maximum BSOC = .006 lb/HP/HR x (%Power/100)  |  |             |
| <b>Engine Physical Specifications</b>  |  |             |
| Weight, Dry, lb. (kg) +/- 2.5%   | 447.1 (202.8)                                |             |
| Minimum runnable engine  | Refer to TCM's Detailed Model Specifications |             |
| Detailed weights by Specification Number   |  |             |
| Overall Dimensions, inches (mm)  |  |             |
| Height   | 32.76  | (832)       |
| Width  | 42.20  | (1072)      |
| Length   | 40.26  | (1023)      |
| Center of Gravity, inches (mm)   |  |             |
| Forward of rear accessory case   | 12.66  | (322)       |
| Below crankshaft centerline  | 1.30   | (33)        |
| Beside crankshaft centerline toward 1-3-5 side   | 0.12   | (3)         |
| Moment of Inertia, standard accessory package, in-lb-sec <sup>2</sup><br>(mm·kg·sec <sup>2</sup> ) |  |             |
| Roll - Longitudinal Axis, (I <sub>x-x</sub> )  | 83   | (956)       |
| Pitch - Lateral Axis, (I <sub>y-y</sub> )  | 105  | (1210)      |
| Yaw - Vertical Axis, (I <sub>z-z</sub> )   | 172  | (1982)      |



**2-3.3. TSIO-550-E Specifications and Operating Limits**

| Table 2-3. TSIO-550-E Specifications & Operating Limits   |  |               |
|---|--|---------------|
| Cylinders   |  |               |
| Model   | TSIO-550-E   |               |
| FAA Type Certificate  | E5SO   |               |
| Installation Drawing Number   | 646618   |               |
| Arrangement   | Individual cylinders horizontally opposed  |               |
| Compression Ratio   | 7.5:1  |               |
| Number of Cylinders   | 6  |               |
| Firing Order  | 1-6-3-2-5-4  |               |
| Time Between Overhaul   | 1600 accumulated operating hours or 12 years   |               |
| Bore  | 5.25 inches  | 13.335 cm     |
| Stroke  | 4.25 inches  | 10.795 cm     |
| Piston Displacement   | 552 cubic inches   | 9.05 L        |
| Crankshaft Speed & Brake Horsepower   |  |               |
| Rated Maximum Continuous Operation*   | 350 bhp -0%+5% @ 2700 rpm  |               |
| Crankshaft Speed (Maximum rated)  | 2700 rpm   |               |
| Engine Idle Speed, Minimum  | 600 rpm  |               |
| Rated Manifold Pressure   | 38.5 in. Hg Full Throttle (Sea Level)  |               |
| Maximum Recommended Cruise  | 262 bhp @ 2500 rpm   |               |
| * Performance is based on sea level, standard day, zero water vapor pressure conditions at the throttle inlet and exhaust exit with no engine accessory load. Standard day conditions are 29.92 in Hg and 59° F. Horsepower will vary approximately 1% for each 6° F (5.6° C) change in throttle inlet air temperature. Correction must also be made for the effect of exhaust backpressure and accessory drive losses. Contact TCM engineering for correction factors for specific applications. |  |               |
| Fuel System Specifications  |  |               |
| Fuel Control System   | TCM Continuous Flow Fuel Injection   |               |
| Fuel Minimum Grade**  | 100LL Blue or 100 Green  |               |
| Russian Commonwealth of Independent States  | B95/130  |               |
| People's Republic of China  | RH95/130***  |               |
| Fuel System Pressure & Flow   | Refer to Chapter 5, "Engine Operational Check"   |               |
| Boost Fuel Pump Specifications  | Refer to TCM's Detailed Model Specifications   |               |
| ** Engine is certified for operation with 100-LL Blue or 100 Green aviation fuel. If the minimum fuel grade is not available, use the next higher grade available; never use a lower grade fuel.  |  |               |
| *** Engine operation with this fuel is limited to 9840 ft (2999 m) at maximum continuous power and speed and 19680 feet (5998 m) at maximum recommended cruise power and speed.   |  |               |
| Fuel Consumption  |  |               |
| Power Level   | BHP (kW)   | lbs./hr (max) |
| Rated Power, 100%   | 350 (261)  | 255           |
| Cruise, 75%   | 263 (196)  | 173           |
| Cruise, 65%   | 228 (170)  | 152           |
| Cruise, 55%   | 193 (138)  | 129           |
| Ignition  |  |               |
| Spark Plugs to be used  | Refer to TCM's Service Information Letter SIL 03-2A "Currently Active Approved Spark Plug Application" |               |
| Ignition Timing   | 24°BTC±1°  |               |
| Spark Plug Gap  | Spark plug manufacturer's specified gap.   |               |



**Engine Description**

| Table 2-3. TSIO-550-E Specifications & Operating Limits   |  |             |
|---|--|-------------|
| <b>Cylinder Head Temperature (measured with bayonet thermocouple)</b>                           |  |             |
| Normal Operational Temperature (cruise)   | 420°F  | 216°C       |
| Maximum Allowable Operational Temperature   | 460°F  | 238°C       |
| Minimum Take-off Temperature  | 240°F  | 116°C       |
| *All temperatures are measured with bayonet thermocouples.                                      |  |             |
| <b>Exhaust</b>  |  |             |
| Exhaust System back-pressure, maximum, measured at port, inches Hg (kPa)                        | 2.5 (8.5)                                    |             |
| EGT Thermocouple Probe, min. location distance from port, in (mm)                               | 2.00/2.50 (50.8/63.5)                        |             |
| <b>Oil</b>  |  |             |
| Oil Pressure – Normal Operation @ 100°F to 240°F (38 to 116°C)*                                 | 30 to 60 psig                                |             |
| Maximum Allowable Oil Pressure* (cold oil)  | 100 psig                                     |             |
| Minimum Oil Pressure @ Idle (600 RPM)*  | 10 psig at or below 200°F                    |             |
| Maximum Allowable Oil Temperature*  | 240°F  | 116°C       |
| Minimum Take-off Oil Temperature*   | 100°F  | 38°C        |
| Cruise Flight Operation Oil Temperature   | 160° to 200°F                                | 71° to 93°C |
| Oil Sump Capacity   | 12.0 Quarts                                  |             |
| Useable Oil - 20° Nose Up (12 quart fill)   | 7.5 Quarts                                   |             |
| Useable Oil – 14.5° Nose Down (12 quart fill)   | 6.5 Quarts                                   |             |
| Recommended Oil Grade, SAE – above 40°F   | 50 or Multi Viscosity                        |             |
| Recommended Oil Grade, SAE – below 40°F   | 30 or Multi Viscosity                        |             |
| Oil Grade, TCM Specification  | MHS-24                                       |             |
| CAUTION: Oil must be aviation oil conforming to MHS-24.   |  |             |
| *Oil pressure and temperature are measured at the oil cooler adapter.                           |  |             |
| <b>Brake Specific Oil Consumption (BSOC)</b>  |  |             |
| Maximum BSOC = .006 lb/HP/HR x (%Power/100)   |  |             |
| <b>Engine Physical Specifications</b>   |  |             |
| Weight, Dry, lb. (kg) +/- 2.5%  | 566 (257)                                    |             |
| Minimum runnable engine   | Refer to TCM's Detailed Model Specifications |             |
| Detailed weights by Specification Number  |  |             |
| Overall Dimensions, inches (mm)   |  |             |
| Height  | 32.76  | (832)       |
| Width   | 42.20  | (1072)      |
| Length  | 40.26  | (1023)      |
| Center of Gravity, inches (mm)  |  |             |
| Forward of rear accessory case  | 11.41  | (289.81)    |
| Below crankshaft centerline   | 1.056  | (26.82)     |
| Beside crankshaft centerline toward 1-3-5 side  | 0.365  | (9.27)      |
| Moment of Inertia, standard accessory package, in-lb·sec <sup>2</sup> (mm·kg·sec <sup>2</sup> ) |  |             |
| Roll - Longitudinal Axis, (I <sub>x-x</sub> )   | 134.3  | (946)       |
| Pitch - Lateral Axis, (I <sub>y-y</sub> )   | 138.79                                       | (1206)      |
| Yaw - Vertical Axis, (I <sub>z-z</sub> )  | 218.972                                      | (1976)      |



2-3.4. TSIO-550-G Specifications and Operating Limits

| Table 2-4. TSIO-550-G Specifications & Operating Limits   |  |               |
|---|--|---------------|
| <b>Cylinders</b>  |  |               |
| Model   | TSIO-550-G   |               |
| FAA Type Certificate  | E5SO   |               |
| Installation Drawing Number   | 657154   |               |
| Arrangement   | Individual cylinders horizontally opposed  |               |
| Compression Ratio   | 7.5:1  |               |
| Number of Cylinders   | 6  |               |
| Firing Order  | 1-6-3-2-5-4  |               |
| Time Between Overhaul   | 2000 accumulated operating hours or 12 years   |               |
| Bore  | 5.25 inches  | 13.335 cm     |
| Stroke  | 4.25 inches  | 10.795 cm     |
| Piston Displacement   | 552 cubic inches   | 9.05 L        |
| <b>Crankshaft Speed &amp; Brake Horsepower</b>  |  |               |
| Rated Maximum Continuous Operation*   | 310 bhp -0%+5% @ 2700 rpm @ 34 in. Hg  |               |
| Crankshaft Speed (Maximum rated)  | 2700 rpm   |               |
| Engine Idle Speed, Minimum  | 600 rpm  |               |
| Rated Manifold Pressure   | 34.0 in. Hg Full Throttle (Sea Level)  |               |
| Maximum Recommended Cruise  | 262 bhp @ 2500 rpm @ 30.5 in. Hg   |               |
| * Performance is based on sea level, standard day, zero water vapor pressure conditions at the throttle inlet and exhaust exit with no engine accessory load. Standard day conditions are 29.92 in Hg and 59° F. Horsepower will vary approximately 1% for each 6° F (5.6° C) change in throttle inlet air temperature. Correction must also be made for the effect of exhaust backpressure and accessory drive losses. Contact TCM engineering for correction factors for specific applications. |  |               |
| <b>Fuel System Specifications</b>   |  |               |
| Fuel Control System   | TCM Continuous Flow Fuel Injection   |               |
| Fuel Minimum Grade**  | 100LL Blue or 100 Green  |               |
| Russian Commonwealth of Independent States  | B95/130  |               |
| People's Republic of China  | RH95/130***  |               |
| Fuel System Pressure & Flow   | Refer to Chapter 5, "Engine Operational Check"   |               |
| Boost Fuel Pump Specifications  | Refer to TCM's Detailed Model Specifications   |               |
| ** Engine is certified for operation with 100-LL Blue or 100 Green aviation fuel. If the minimum fuel grade is not available, use the next higher grade available; never use a lower grade fuel.  |  |               |
| *** Engine operation with this fuel is limited to 9840 ft (2999 m) at maximum continuous power and speed and 19680 feet (5998 m) at maximum recommended cruise power and speed.   |  |               |
| <b>Fuel Consumption</b>   |  |               |
| Power Level   | BHP (kW)   | lbs./hr (max) |
| Rated Power, 100%   | 310 (231)  | 210           |
| Max. Cruise, 85%  | 262 (196)  | 155           |
| Cruise, 75%   | 233 (174)  | 127           |
| Cruise, 65%   | 202 (115)  | 102           |
| <b>Ignition</b>   |  |               |
| Spark Plugs to be used  | Refer to TCM's Service Information Letter SIL 03-2A "Currently Active Approved Spark Plug Application" |               |
| Ignition Timing   | 24°BTC±1°  |               |
| Spark Plug Gap  | Spark plug manufacturer's specified gap.   |               |



| Table 2-4. TSIO-550-G Specifications & Operating Limits  |  |             |
|--|--|-------------|
| <b>Cylinder Head Temperature (measured with bayonet thermocouple)</b>                              |  |             |
| Normal Operational Temperature (cruise)  | 420°F  | 216°C       |
| Maximum Allowable Operational Temperature  | 460°F  | 238°C       |
| Minimum Take-off Temperature   | 240°F  | 116°C       |
| *All temperatures are measured with bayonet thermocouples.   |  |             |
| <b>Exhaust</b>   |  |             |
| Exhaust System back-pressure, maximum, measured at port, inches Hg (kPa)                           | 2.5 (8.5)                                    |             |
| EGT Thermocouple Probe, min. location distance from port, in (mm)                                  | 2.00/2.50 (50.8/63.5)                        |             |
| <b>Oil</b>   |  |             |
| Oil Pressure – Normal Operation @ 100°F to 240°F (38 to 116°C)*                                    | 30 to 60 psig                                |             |
| Maximum Allowable Oil Pressure* (cold oil)   | 100 psig                                     |             |
| Minimum Oil Pressure @ Idle (600 RPM)*   | 10 psig at or below 200°F                    |             |
| Maximum Allowable Oil Temperature*   | 240°F  | 116°C       |
| Minimum Take-off Oil Temperature*  | 100°F  | 38°C        |
| Cruise Flight Operation Oil Temperature  | 160° to 200°F                                | 71° to 93°C |
| Oil Sump Capacity  | 8.0 Quarts                                   |             |
| Useable Oil - 16° Nose Up (8 quart fill)   | 5.0 Quarts                                   |             |
| Useable Oil – 10° Nose Down (8 quart fill)   | 4.5 Quarts                                   |             |
| Recommended Oil Grade, SAE – above 40°F  | 50 or Multi Viscosity                        |             |
| Recommended Oil Grade, SAE – below 40°F  | 30 or Multi Viscosity                        |             |
| Oil Grade, TCM Specification   | MHS-24                                       |             |
| CAUTION: Oil must be rated for aviation use, conforming to MHS-24.                                 |  |             |
| *Oil pressure and temperature are measured at the oil cooler adapter.                              |  |             |
| <b>Brake Specific Oil Consumption (BSOC)</b>   |  |             |
| Maximum BSOC = .006 lb/HP/HR x (%Power/100)  |  |             |
| <b>Engine Physical Specifications</b>  |  |             |
| Weight, Dry, lb. (kg) +/- 2.5%   | 554 (251)                                    |             |
| Minimum runnable engine  | Refer to TCM's Detailed Model Specifications |             |
| Detailed weights by Specification Number   |  |             |
| Overall Dimensions, inches (mm)  |  |             |
| Height   | 35.4   | (899.9)     |
| Width  | 35.9   | (912.4)     |
| Length   | 40.3   | (1022)      |
| Center of Gravity, inches (mm)   |  |             |
| Forward of rear accessory case   | 11.41  | (289.8)     |
| Below crankshaft centerline  | 1.056  | (26.8)      |
| Beside crankshaft centerline toward 1-3-5 side   | 0.365  | (9.27)      |
| Moment of Inertia, standard accessory package, in-lb-sec <sup>2</sup><br>(mm·kg·sec <sup>2</sup> ) |  |             |
| Roll - Longitudinal Axis, (I <sub>x-x</sub> )  | 134.3  | (946)       |
| Pitch - Lateral Axis, (I <sub>y-y</sub> )  | 138.79                                       | (1206)      |
| Yaw - Vertical Axis, (I <sub>z-z</sub> )   | 218.9  | (1976)      |



### 2-3.5. TSIO-550 Accessory Drive Ratios

TSIO-550 Permold series engine accessory drive ratios are the same for all models.

| Table 2-5. Accessory Drive Ratios, Rotation, Speed, Torque & Moments |                         |                           |                            |        |                                     |
|--|-------------------------|---------------------------|----------------------------|--------|-------------------------------------|
| Accessory  | Direction of Rotation ① | Drive Ratio to Crankshaft | Maximum Torque, (in.-lbs.) |        | Maximum Overhang Moment, (in.-lbs.) |
|  |                         |                           | Cont.                      | Static |                                     |
| Optional Tachometer  | CCW                     | 0.5:1                     | 7                          | 50     | 25                                  |
| Magneto  | CCW                     | 1.5:1                     | -                          | -      | -                                   |
| Starter Motor  | CCW                     | 48:1                      | 200                        | 400    | 60                                  |
| Alternator (gear-driven)   | CCW                     | 3:1                       | 150                        | 800    | 150                                 |
| Propeller Governor ④   | CW                      | 1:1                       | 29                         | 825    | 50                                  |
| Fuel Pump  | CW                      | 1:1                       | 25                         | 680    | 60                                  |
| Accessory Drives②  | CW                      | 1.5:1                     | 100                        | 800    | 40                                  |
| Optional Accessory Drive ③   | CCW                     | 3:1                       | 100                        | 500    | N/A                                 |
| Oil Cooler   | --                      | --                        | --                         | --     | 55 wet                              |

① CW = Clockwise Rotation CCW = Counterclockwise Rotation. View is facing drive.  
 ② One drive is eligible at 160 in lb continuous torque load providing the other does not exceed 100 in lb continuous torque load. Drive pads are per AND 20000, optionally, per MS3325 modified, and shall be provided with covers.  
 ③ . Belt tension 70 lb. (may be used with appropriate optional equipment kit to drive an airframe provided refrigerant compressor)  
 ④ This drive is a modified AND 20010 and shall be supplied with a cover

#### 2-3.5.1. Accessory Drive Pad

The accessory drive pad is an AND20000 specification that has been modified for speed, torque, and moment. The drive pad is provided with a cover in the event that its use is not required.

### 2-3.6. Oil Specifications

**WARNING**

**Use only the oils specified to service the engine.**

The commercially available ashless dispersant aviation oils listed in “Recommended Ashless Dispersant Aviation Engine Oils” conform to TCM’s oil specifications. A list of qualified lubricants is provided with the Engine Oil Servicing instructions in Chapter 5. Do not use any other commercial quality oil.

| Table 2-6. Engine Oil Type Requirements            |                           |
|--|---------------------------|
| Recommended Grade of Ashless Dispersant Engine Oil | Oil Type                  |
| Above 40°F (4°C), Ambient Air (Sea Level)          | SAE 50 or Multi Viscosity |
| Below 40°F (4°C), Ambient Air (Sea Level)          | SAE 30 or Multi Viscosity |

### 2-3.6.1. Break-in Oil

NOTE: Mineral oil conforming to SAEJ1966 contains a corrosion preventive additive and must not be used for more than 25 hours or six months, whichever occurs first. If oil consumption has not stabilized in this time, drain and replenish the mineral oil and replace the oil filter.

The break-in mineral oil used in these engines must conform to the SAEJ1966 standard:

### 2-3.6.2. Recommended Ashless Dispersant Aviation Engine Oils

Lubricating oil qualified under SAEJ1899 or SAEJ1966 shall be considered qualified under MHS-24. Lubricating oils classified by the North Atlantic Treaty Organization (NATO) Standardization Agreement (STANAG) as interchangeable with oils qualified under J1899 or J1966 and assigned NATO Codes 0-123 and 0-128 shall be considered qualified under MHS-24.

### 2-3.7. Performance Data

Refer to the applicable TCM Detailed Model Specification For complete engine technical specifications, installation requirements, certification data, and engine test stand performance.

#### **WARNING**

**The performance charts included in this manual indicate uninstalled engine performance under controlled conditions and will vary from installed performance. The charts are neither intended nor suitable for installed performance specifications or flight planning. Consult the Airplane Flight Manual or Pilot's Operating Handbook for installed aircraft performance specification.**





### 2-3.7.1. TSIO-550-B Performance Charts

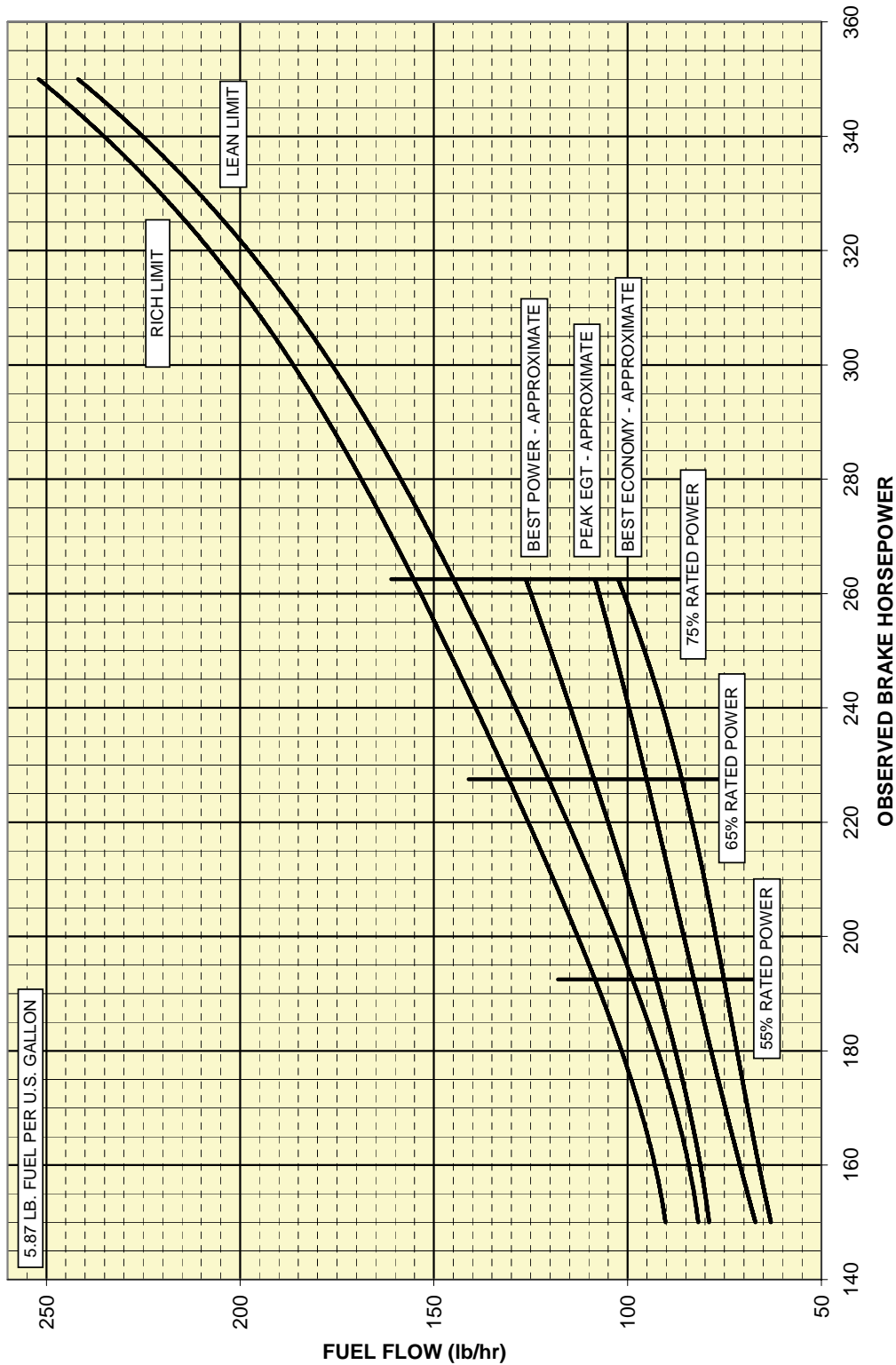

Figure 2-18. TSIO-550-B Fuel Flow vs. Brake Horsepower

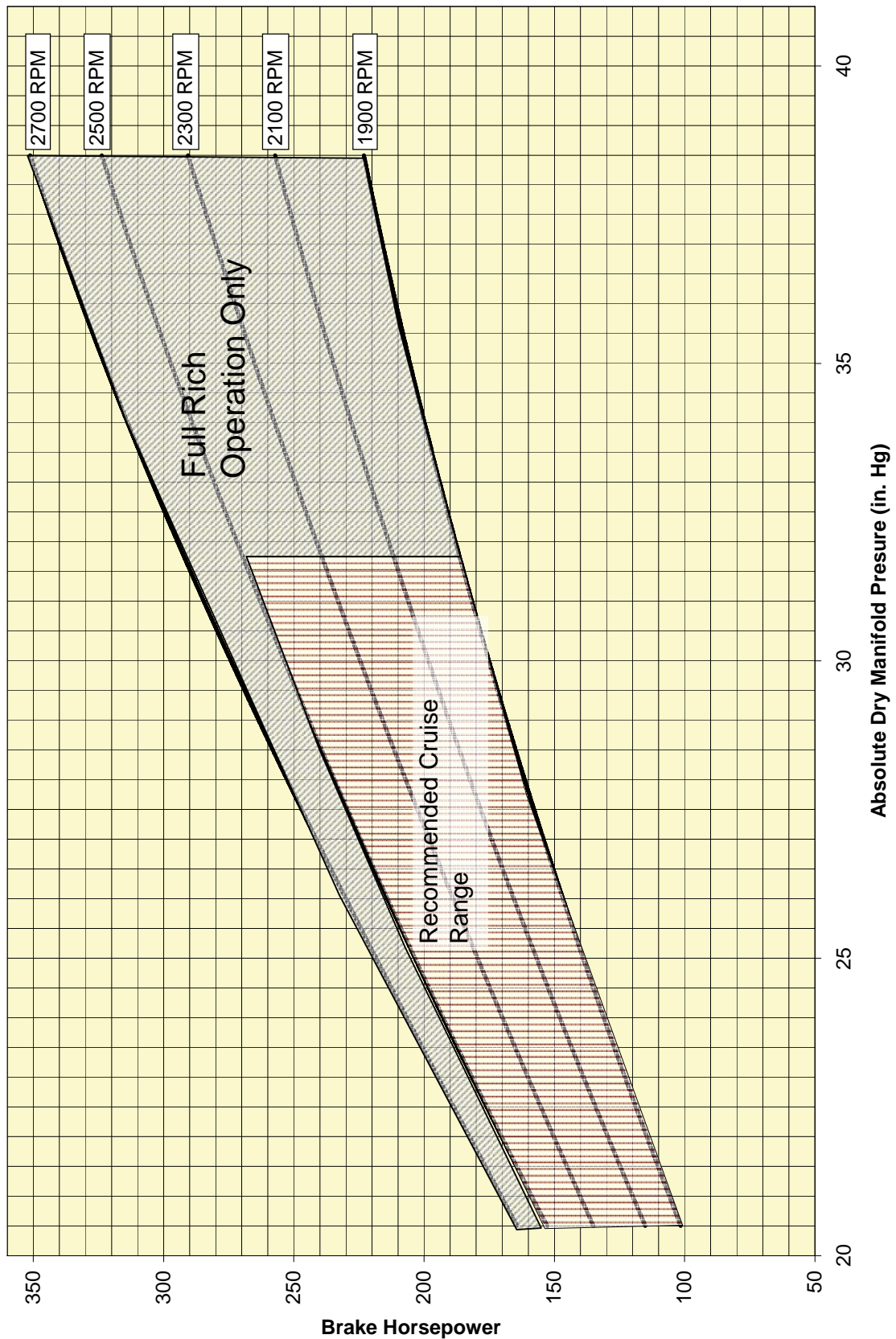

Figure 2-19. TSIO-550-B Sea Level Performance

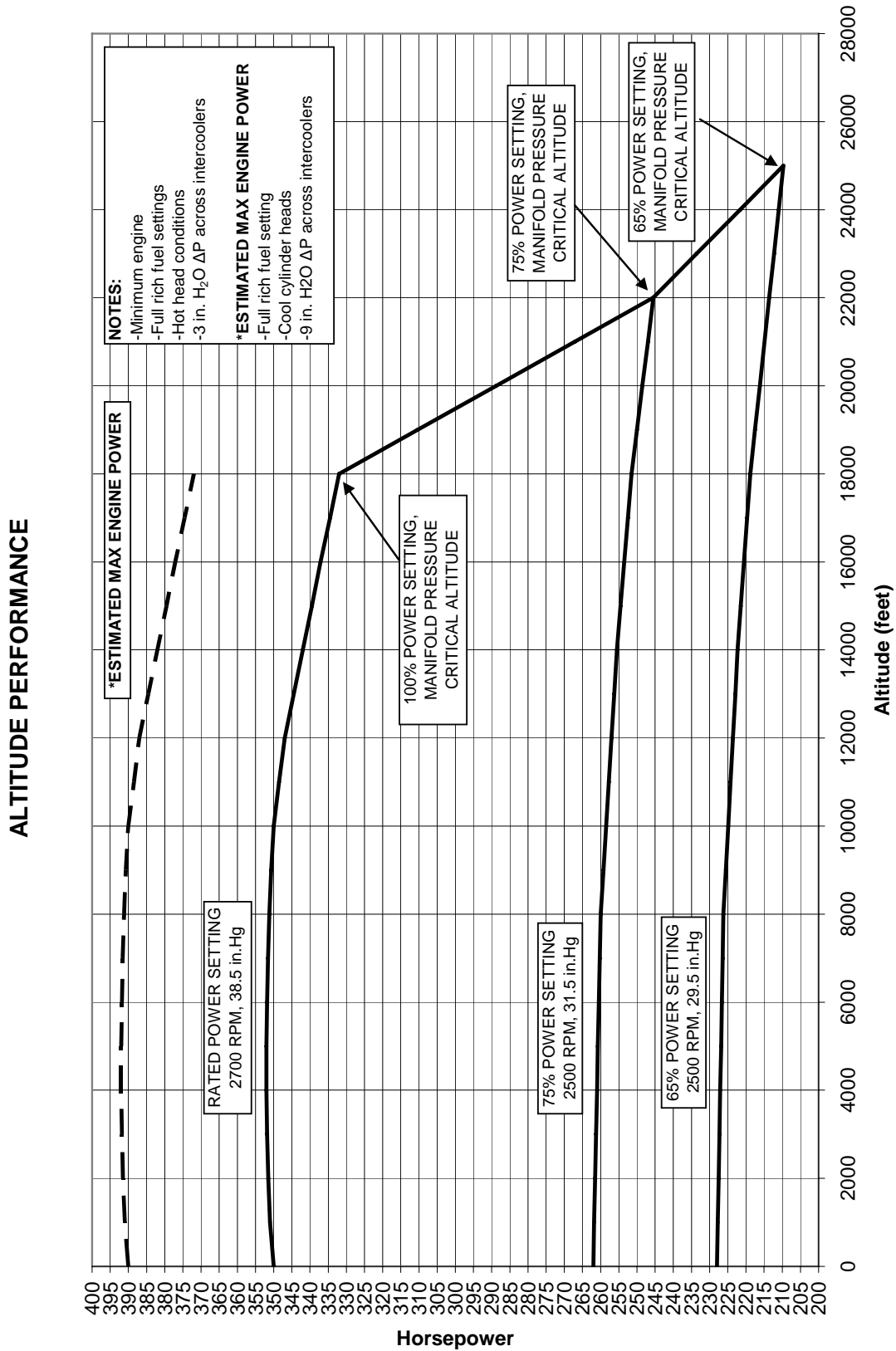

Figure 2-20. TSIO-550-B Altitude Performance



2-3.7.2. TSIO-550-C Performance Charts

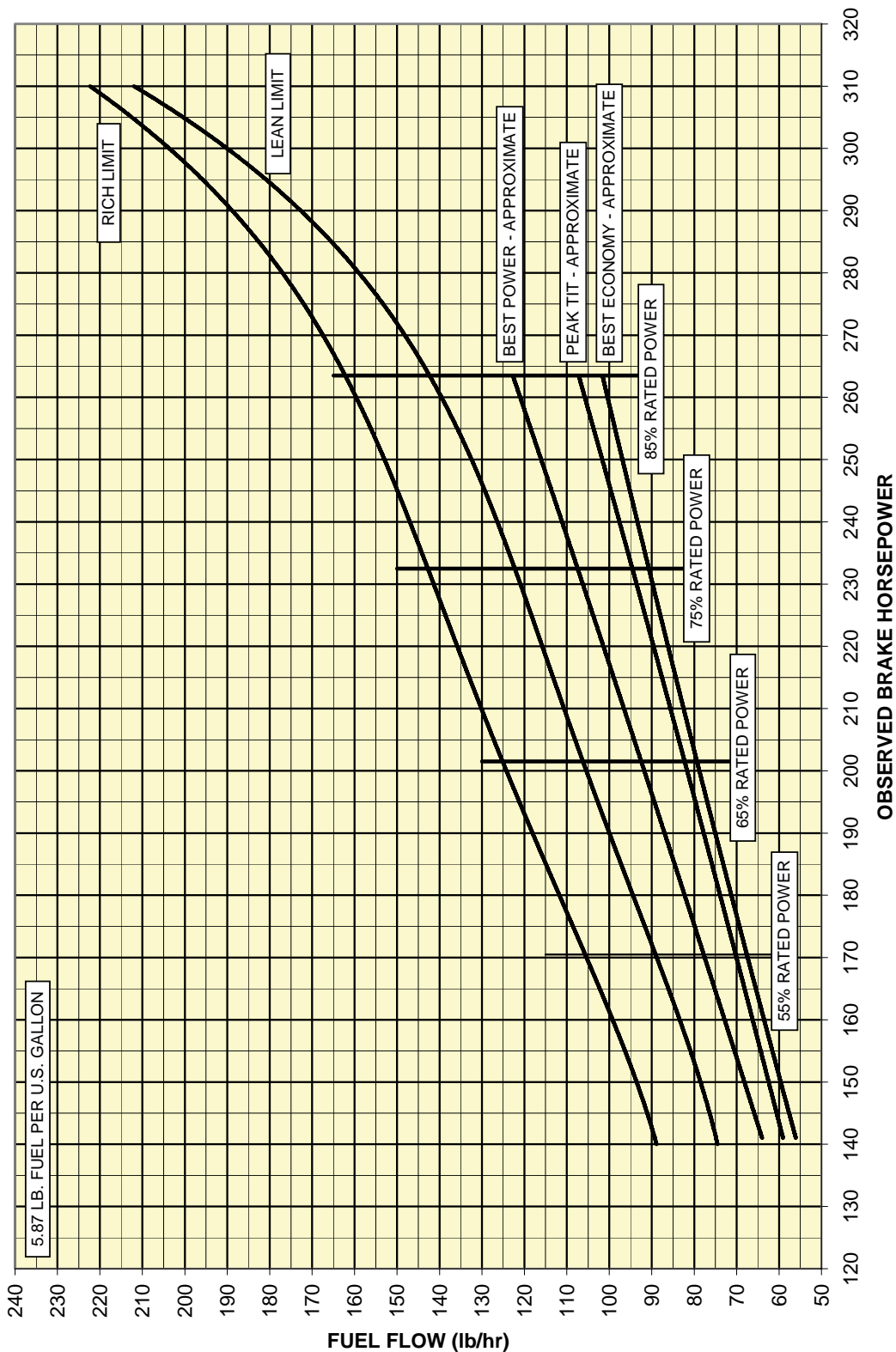

Figure 2-21. TSIO-550-C Fuel Flow vs. Brake Horsepower

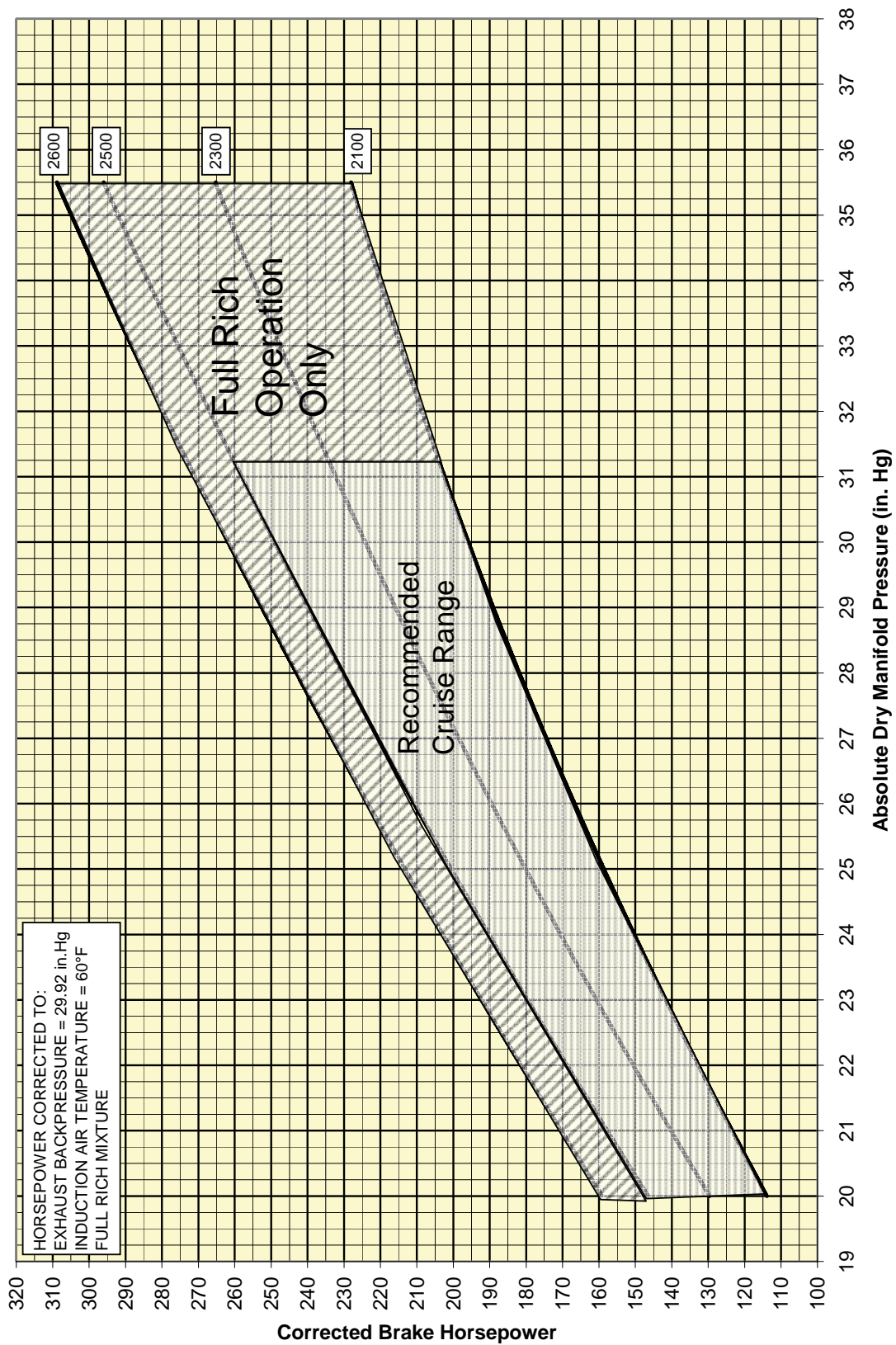

Figure 2-22. TSIO-550-C Seal Level Performance

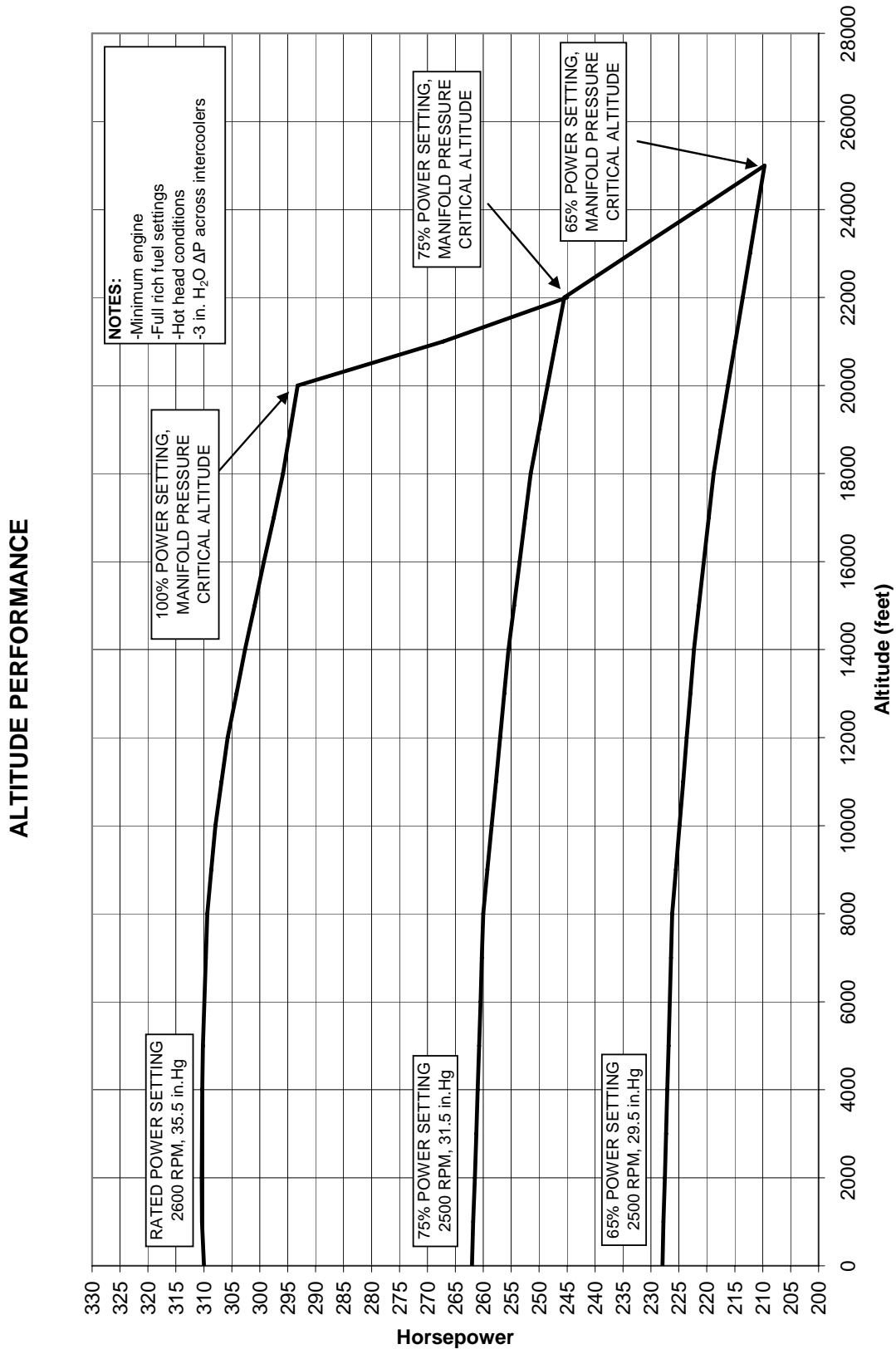

Figure 2-23. TSIO-550-C Altitude Performance



### 2-3.7.3. TSIO-550-E Performance Charts

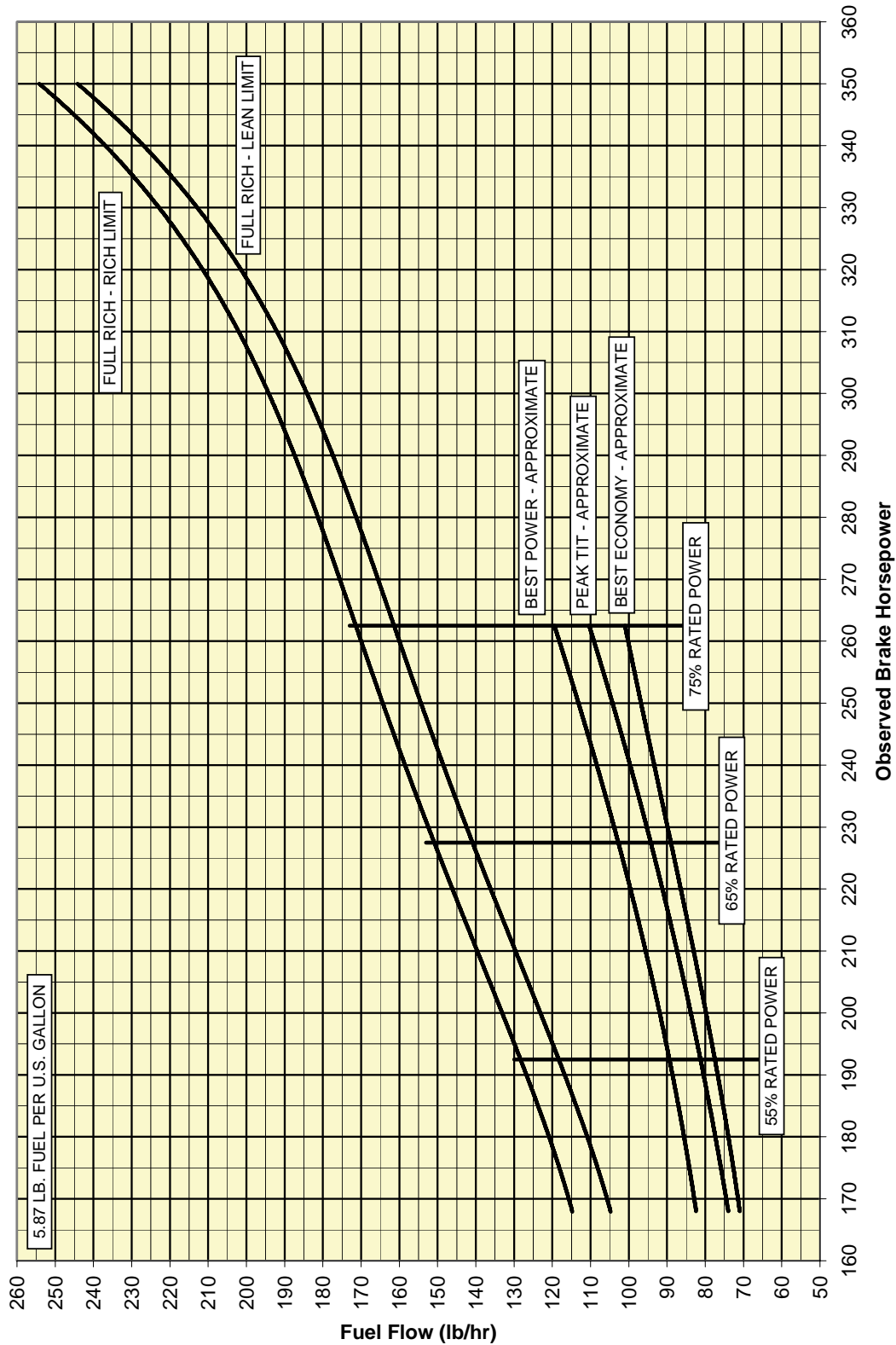

Figure 2-24. TSIO-550-E Fuel Flow vs. Brake Horsepower

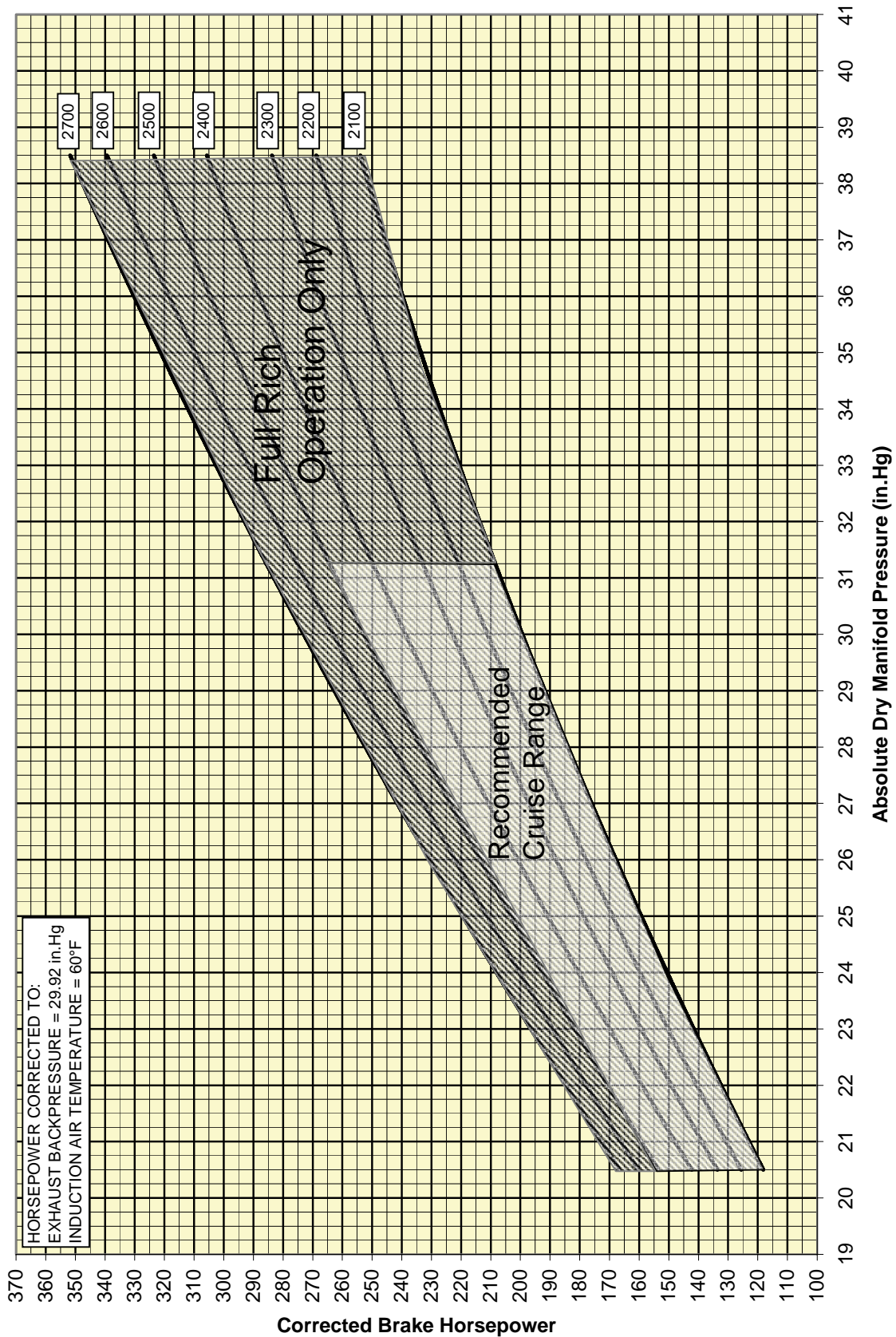

Figure 2-25. TSIO-550-E Sea Level Performance



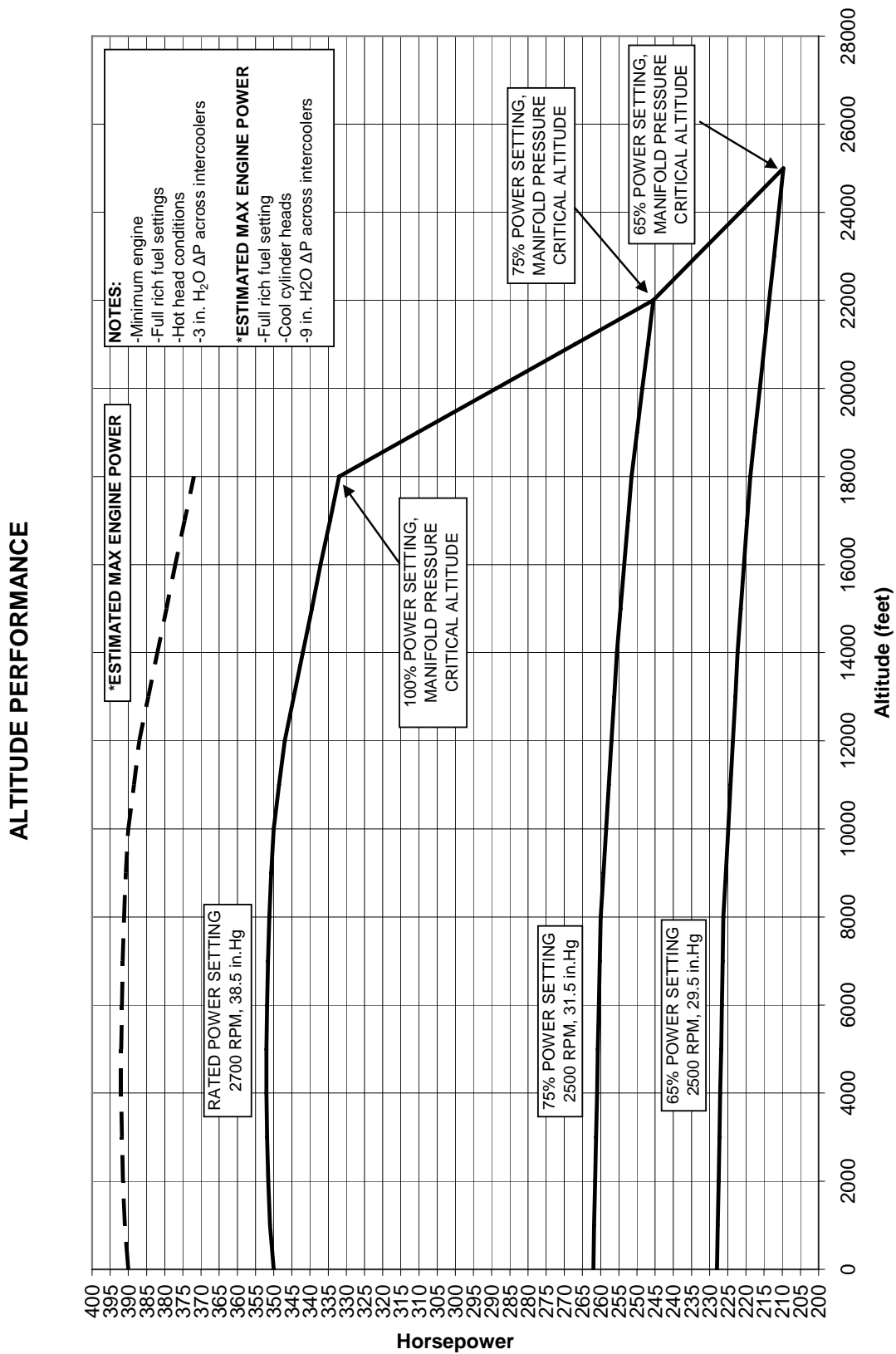

Figure 2-26. TSIO-550-E Altitude Performance



2-3.7.4. TSIO-550-G Performance Charts

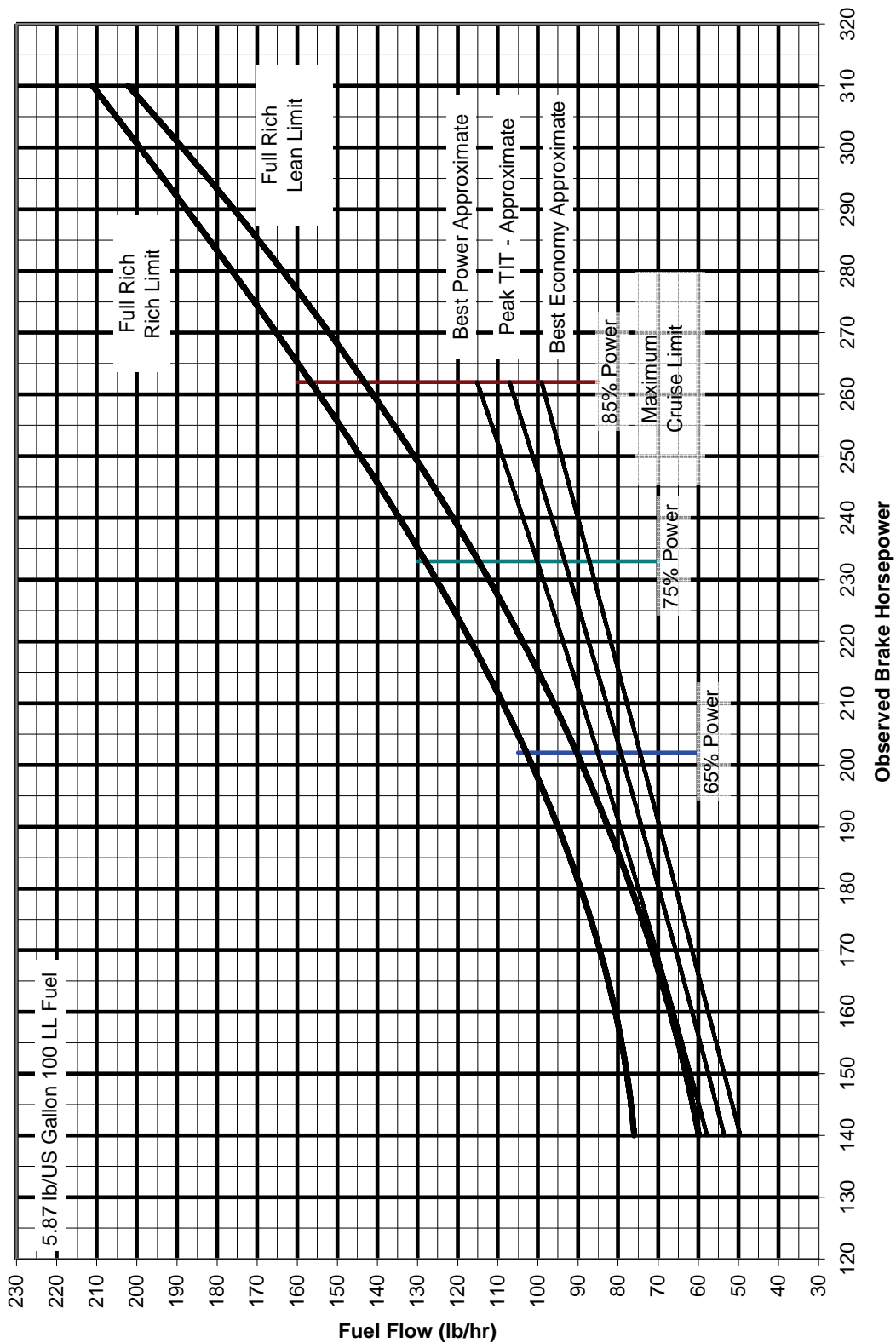

Figure 2-27. TSIO-550-G Fuel Flow vs. Brake Horsepower

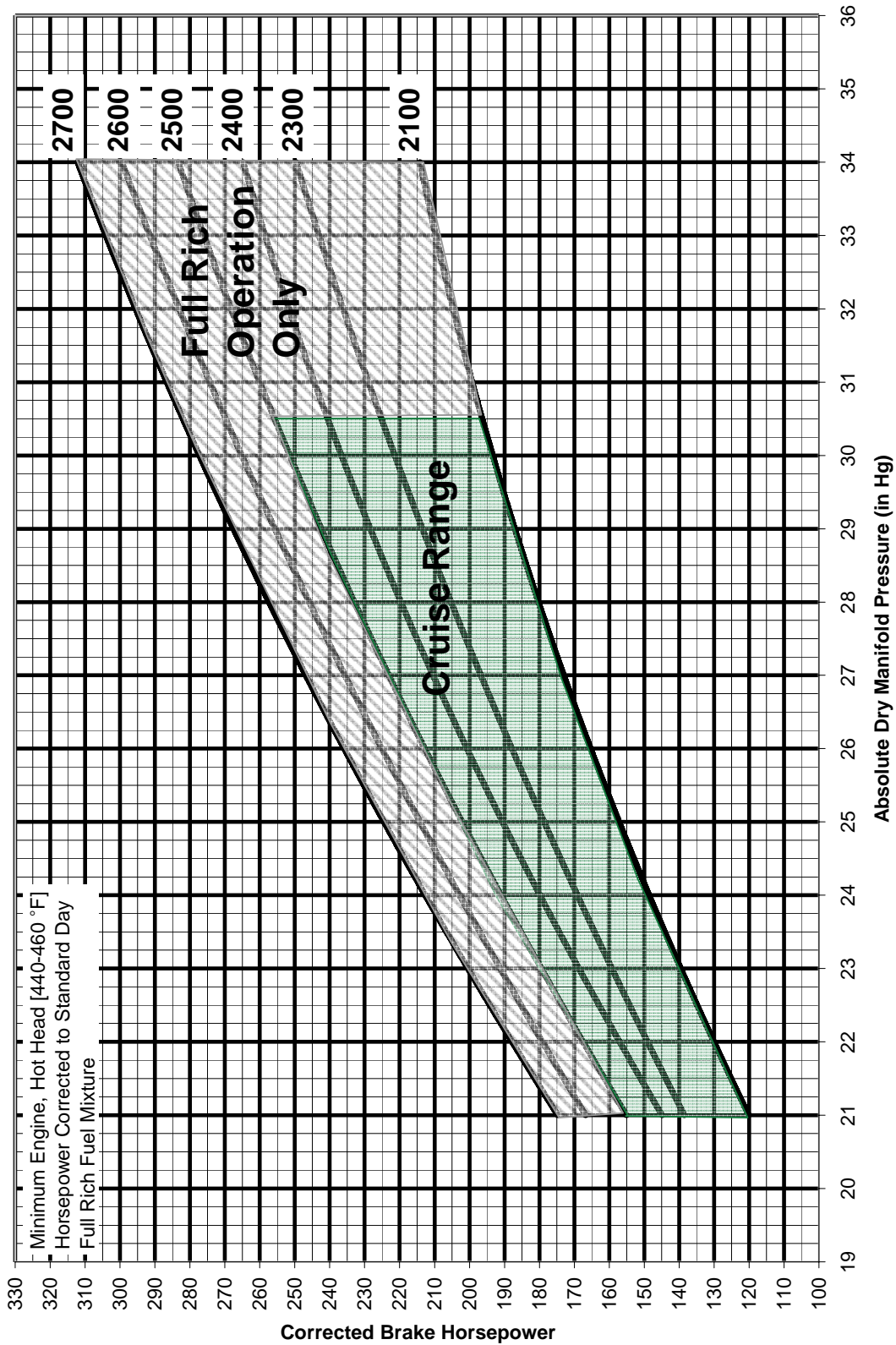

Figure 2-28. TSIO-550-G Sea Level Performance

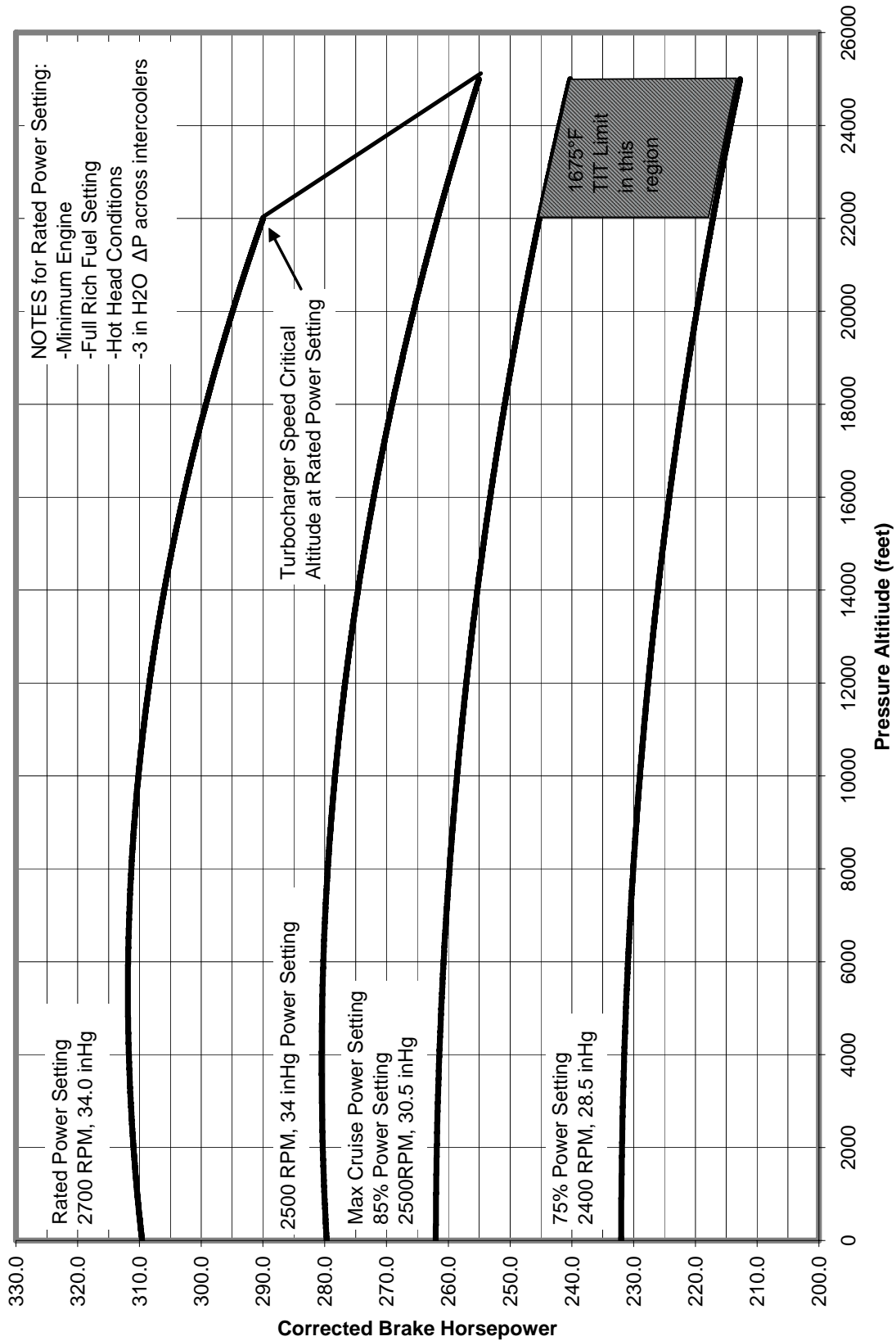

Figure 2-29. TSIO-550-G Altitude Performance



---

## **Chapter 3. AIRWORTHINESS LIMITATIONS**

### **CONTENTS**

|  |            |
|--|------------|
| <b>Chapter 3. Airworthiness Limitations .....</b>              | <b>3-1</b> |
| 3-1. Mandatory Replacement Times.....                          | 3-2        |
| 3-2. Mandatory Inspection Intervals.....                       | 3-2        |
| 3-3. Other Related Procedures .....                            | 3-2        |
| 3-4. Distribution of Changes to Airworthiness Limitations..... | 3-2        |



## **FAA APPROVED**

The Airworthiness Limitations Section is FAA approved and specifies maintenance required under §§ 43.16 and 91.403 of the Federal Aviation Regulations unless an alternative program has been FAA approved. Federal Aviation Regulations §§ 43.16 and 91.403 require owner/operator compliance with all maintenance limitations in this section concerning mandatory replacement times, inspection intervals, and other related procedures that are specific to this engine. Any such limitations listed below are part of the design limits of the engine, which was type certified based upon required owner/operator compliance with the limitations.

### **3-1. Mandatory Replacement Times**

Subject to additional information contained in FAA Airworthiness Directives issued after the date of certification, the engines covered in this manual do not contain any components having mandatory replacement times required by type certification.

### **3-2. Mandatory Inspection Intervals**

Subject to additional information contained in FAA Airworthiness Directives issued after the date of certification, the engines covered in this manual do not require specific intervals of inspection pursuant to type certification.

### **3-3. Other Related Procedures**

Subject to additional information contained in Airworthiness Directives issued after the date of certification, there are no other related procedures required pursuant to the type certification for the engines covered in this manual.

### **3-4. Distribution of Changes to Airworthiness Limitations**

Changes to this Airworthiness Limitations Section constitute changes to the type design of the engines covered in this manual and require FAA approval pursuant to Federal Aviation Regulations. Such changes, which result in new or more restrictive limits, will be published in FAA Airworthiness Directives.

NOTE: The limitations in this section apply only to specific limitations that are part of the engine design. Under Federal Aviation Regulations, numerous other additional limitations are applicable to this engine and its accessories. For example Federal Aviation Regulation Parts 91 and 43, among other parts, define inspection criteria, maintenance requirements, and procedures that are applicable to this engine. It is the responsibility of the owner/operator to maintain the engine in an airworthy condition by complying with all applicable Federal Aviation Regulations and by performing maintenance in accordance with TCM Instructions for Continued Airworthiness.



## Chapter 4. ENGINE INSTALLATION

### CONTENTS

**Chapter 4. Engine Installation..... 4-1**

4-1. Materials Required for Engine Installation ..... 4-3

    4-1.1. Common Tools and Consumable Supplies Required ..... 4-4

    4-1.2. Special Tool and Material Vendors ..... 4-5

4-2. Engine Receipt and Handling ..... 4-6

    4-2.1. Uncrating the Engine ..... 4-6

    4-2.2. Crating an Engine for Shipping ..... 4-6

    4-2.3. Acceptance Inspection ..... 4-6

    4-2.4. Engine Transport ..... 4-7

4-3. Installation Procedures ..... 4-7

    4-3.1. Prepare the Airframe for Engine Installation..... 4-7

    4-3.2. Prepare the Engine for Installation ..... 4-7

    4-3.3. Installation Sequence ..... 4-10

    4-3.4. Installation Inspection..... 4-19

    4-3.5. Preflight and Run-up ..... 4-22

4-4. TSIO-550 Installation Drawings ..... 4-23

    4-4.1. TSIO-550 Common Installation Drawings..... 4-23

    4-4.2. TSIO-550-B Installation Drawings..... 4-25

    4-4.3. TSIO-550-C & E Installation Drawings ..... 4-30

    4-4.4. TSIO-550-G Installation Drawings ..... 4-35

### LIST OF TABLES

Table 4-1. Special Tool List..... 4-3

Table 4-2. Special Tool/Material Vendors and Suppliers..... 4-5



---

**LIST OF FIGURES**

|  |      |
|--|------|
| Figure 4-1. TSIO-550 Exhaust System.....                     | 4-13 |
| Figure 4-2. TSIO-550 Turbochargers .....                     | 4-14 |
| Figure 4-3. Crankcase Ventilation Hose Routing .....         | 4-15 |
| Figure 4-4. Exhaust Port Dimensions .....                    | 4-23 |
| Figure 4-5. Propeller Flange Dimensions .....                | 4-24 |
| Figure 4-6. TSIO-550-B Front View .....                      | 4-25 |
| Figure 4-7. TSIO-550-B Rear View .....                       | 4-26 |
| Figure 4-8. TSIO-550-B Top View .....                        | 4-27 |
| Figure 4-9. TSIO-550-B Left Side View .....                  | 4-28 |
| Figure 4-10. TSIO-550-B Right Side View.....                 | 4-29 |
| Figure 4-11. TSIO-550-C & E Front View.....                  | 4-30 |
| Figure 4-12. TSIO-550-C & E Rear View.....                   | 4-31 |
| Figure 4-13. TSIO-550-C & E Top View.....                    | 4-32 |
| Figure 4-14. TSIO-550-C & E Left Side View.....              | 4-33 |
| Figure 4-15. TSIO-550-C & E Right Side.....                  | 4-34 |
| Figure 4-16. TSIO-550-G Front View.....                      | 4-35 |
| Figure 4-17. TSIO-550-G Rear View .....                      | 4-36 |
| Figure 4-18. TSIO-550-G Top View .....                       | 4-37 |
| Figure 4-19. TSIO-550-G Left Side View.....                  | 4-38 |
| Figure 4-20. TSIO-550-G Right Side View.....                 | 4-39 |
| Figure 4-21. TSIO-550-G Alternator and Throttle Detail ..... | 4-40 |





This chapter provides information necessary to receive, prepare and install a replacement engine of the same type, model, and specification as the one removed from the airframe. Engine Installation Drawings, divided by engine model, are located at the end of the chapter for reference.

### 4-1. Materials Required for Engine Installation

The items in the Special Tool List (Table 4-1) apply to engine installation.

| Table 4-1. Special Tool List  |  |                                |             |
|---|--|--------------------------------|-------------|
| Special Tools*  | Use or Reference   | Suggested Providers*           | Part Number |
| Test Club   | Testing  | Hartzell                       | Hartzell    |
| Porta-Test Model #20 ATM-C  | Fuel Pump Calibration  | Approved Aircraft Accessories  | 20 ATM-C    |
| Calibrated Gauges***  | Fuel Pump Calibration  | ---                            | ---         |
| Generator/Alternator Output Test  | Check generator/alternator output.   | Borroughs**                    | 8091        |
| Alternator Analyzer Voltage Regulator Tester  | Check alternator voltage regulation.   | Eastern Technology Corporation | 647         |
| Alternator/Regulator/Battery Tester   | Check battery and alternator voltage regulation.   | Eastern Technology Corporation | E100        |
| Voltage and Circuit Tester  | Check circuit voltage.   | Eastern Technology Corporation | Model 29    |
| EGT/CHT Tester  | Check Exhaust Gas Temperature/ Cylinder Head Temperature/ Turbine Inlet Temperature Accuracy | Alcor, Inc.                    | ALCAL® 2000 |
| Oil Filter Can Cutter   | Inspect particles in oil filter element.   | Federal Mogul                  | CT-470      |
| * Providers are subject to change and may discontinue manufacturing tools.<br>** Kell-Strom Tool Company has the manufacturing rights for Borroughs and Kent-Moore tools.<br>*** Required if using to check fuel pressure as instructed in the section entitled "Fuel Pressure Operational Check with Calibrated Gauges" in Chapter 5 of this manual. |  |                                |             |



### **4-1.1. Common Tools and Consumable Supplies Required**

In addition to a full complement of mechanic's tools, the following tools and materials are required for engine installation:

1. Hoist
2. Oil conforming to SAEJ 1966 (break-in oil, non-dispersant mineral oil) MIL-C-6529 Type II (Break-in oil – non-dispersant mineral oil).
3. Ashless dispersant oil conforming to SAEJ 1899
4. MIL-P-46002, Grade 1 oil
5. 100-LL Blue or 100 Green aviation fuel
6. Spark plugs and copper gaskets
7. Safety Wire (.032")
8. Cable ties
9. Bladder-type pressure pot (at least 1 gallon capacity)
10. Type 1 flammable fuel container
11. Clean fuel hoses
12. AN union fittings
13. Rubber grommets
14. MS 122 DF Spray (available from Miller-Stephenson)
15. Anti-Seize compound
16. Loctite Hydraulic Sealant
17. Loctite Pipe Sealant



**4-1.2. Special Tool and Material Vendors**

NOTE: Items with TCM part numbers may be purchased from Teledyne Continental Motors, Inc.

| Table 4-2. Special Tool/Material Vendors and Suppliers              |  |  |                               |  |
|---|--|--|-------------------------------|--|
| Supplier  | Address  | Phone  | FAX                           | Web Address* or Email  |
| Alcor, Inc.   | 300 Breesport, San Antonio, TX 78216   | 800-354-7233,<br>210-349-6491                        | 210-308-8536                  | www.alcorav.com<br>Support@alcorinc.com  |
| Approved Aircraft Accessories                                       | PO Box 666, Taylor, MI 48180   | 800-521-1046   | 734-946-5547                  | www.approvedaircraft.net<br><a href="http://approved@provide.net">approved@provide.net</a> |
| Borroughs   | (See Kell-Strom Tools information)   |  |                               |  |
| A. W. Chesterton Company  | 225 Fallon Road, Stoneham, MA 02180-9101 USA   | 800-835-4135,<br>781-438-7000                        | 781-438-8971                  | www.chesterton.com<br>Info@chesterton.com  |
| CRC Industries/ Chemical Products                                   | 885 Louis Drive, Warminster, PA 18974  | 800-272-4620,<br>800-556-5074                        | 800-272-4560,<br>215-674-2196 | www.crcindustries.com<br>webmaster@crcindustries.com                                       |
| Davis Inotek Instruments  | 4701 Mount Hope Drive, Baltimore, MD 21215   | 800-358-5525   | 888-818-3981                  | inotek.com   |
| Dow Corning Corporation   | P.O. Box 997, South Saginaw Road, Midand, MI 48686   | 517-496-6000,<br>Distributor Info:<br>1-800-248-2481 |                               | dowcorning.com   |
| Eastern Technology Corporation                                      | 180 Roberts St., East Hartford CT 06108  | 860-528-9821   |                               | easterntech.com  |
| Electrosystems  | See Kelly Aerospace  |  |                               |  |
| Federal Mogul   | 26555 Northwestern Hwy. Southfield, Michigan 48034   | 248-354-7700   | 248-354-8950                  | www.federal-mogul.com  |
| Kell-Strom Tools Company  | 214 Church Street Wethersfield, CT 06109   | 800-851-6851<br>860-529-6851                         | 860-257-9694                  | www.kell-strom.com   |
| Kelly Aerospace   | Power Systems<br>1400 East South Boulevard<br>Montgomery, AL 36116                                     | 877-359-5355   |                               | www.kellyaerospace.com   |
| Kent-Moore  | See Kell-Strom Tools Information   |  |                               |  |
| Miller-Stephenson Chemical Company                                  | 6348 Oakton St., Morton Grove, IL 60053  | 847-966-2022,<br>Technical Info:<br>800-992-2424     | 847-966-8468                  | www.miller-stephenson.com  |
| Shell Oil Company   | P.O. Box 4320, Houston, TX 77210   | 713-241-4819   | 713-241-6511                  |  |
| Unison Industries (Slick)   | Unison Industries<br>ATTN: Subscription<br>Department<br>7575 Baymeadows Way<br>Jacksonville, FL 32256 | 904-739-4201   | 904-739-4006                  | www.unisonindustries.com/news/service_documents.html                                       |
| *Unless otherwise indicated, type http:// and then the web address. |  |  |                               |  |

## 4-2. Engine Receipt and Handling

When the engine arrives, inspect the crating for damage. If the engine crating appears damaged, contact TCM's Service Department (refer to the "TCM Contact Information" in Chapter 1 of this manual) and the freight shipping company. If the crating appears intact, proceed to the section "Uncrating the Engine".

### 4-2.1. Uncrating the Engine

1. Remove the four lag screws attaching the wooden cover to the base.
2. Lift the wooden cover and remove it.
3. Open the plastic bag wrapped around the engine.
4. Inspect the engine per instructions in the section "Acceptance Inspection" in this chapter.

NOTE: Environmental conditions (humidity), seasonal changes, and engine usage influence susceptibility to corrosion. In areas of high humidity, corrosion can occur within 2 days of uncrating the engine. The owner/operator is responsible for recognizing the risk of corrosion and taking the appropriate precautions.

5. If the engine is to be preserved, follow the instructions in Chapter 6 of this manual.

### 4-2.2. Crating an Engine for Shipping

If an engine needs to be returned to TCM or shipped to another location, crate the engine for shipping as follows:

1. Lower the engine onto the container base.
2. Attach the engine using shock mounts and bolts.
3. Cover the engine with a plastic bag.
4. Install and attach the container cover to the base.

### 4-2.3. Acceptance Inspection

1. Verify the engine serial number and model number on the engine nameplate are the same as specified in the engine logbook and the packing slip.
2. Inspect the engine for any signs of damage or corrosion.
  - a. If the engine exhibits no sign of damage or corrosion, proceed with installation. If the engine is to be installed within 30 days of unpacking, proceed to the section "Engine Preparation" in this chapter.
  - b. If the engine appears damaged or corroded, contact TCM's Service Department (refer to the "TCM Contact Information" in Chapter 1). Do not install a damaged or corroded engine or place it in storage.



#### 4-2.4. Engine Transport

Refer to the Installation Drawings at the end of this chapter for engine lifting eyes locations.

1. Take up slack on the hoist prior to loosening the engine mount bolts; remove the bolts from the shipping shock mounts.

*CAUTION: Do not allow chains to become entangled on the engine or its hardware. Be sure the area is clear when lifting the engine. Do not allow the front, rear, sides or bottom of the engine to strike any obstructions as the extreme weight may damage the engine or its components.*

2. Lift the engine and install it on a transportation stand or dolly.

#### 4-3. Installation Procedures

##### 4-3.1. Prepare the Airframe for Engine Installation

1. The following airframe components must be installed and in working order:
  - a. Aircraft fuel filter.
  - b. Aircraft fuel boost pump.
2. Clean the aircraft fuel strainer and allow at least 1 gallon of fuel to flow through the strainer and fuel supply line.

#### **WARNING**

**Purge the aircraft fuel tanks and lines to remove all contamination prior to installation of the main fuel inlet line to the fuel pump. Failure to purge contamination may cause erratic Fuel Injection System operation.**

**Fuel injectors are sensitive to dirt and particulate contamination. To avoid contamination, do not disconnect fuel line connections between the fuel pump and the fuel injectors.**

3. Replace all aircraft flexible oil and fuel hoses before engine installation.
4. Purge all aircraft fuel tanks and fuel lines to remove contaminants prior to installing any engine fuel line.

##### 4-3.2. Prepare the Engine for Installation

This procedure applies to new, overhauled or stored engines. The objective is to remove packing material and tags, and the preservative fluid from the sump and fuel injection systems prior to installation.



NOTE: If the engine is not installed immediately, preserve it according to instructions in Chapter 6, "Engine Preservation and Storage."

1. Remove the shipping plugs or dehydrator plugs from the spark plug holes.
2. Remove the AN-4060 protectors from the ignition leads.
3. Place a basin under the engine to catch the cylinder preservation oil.

NOTE: A small amount of preservative oil remaining in the cylinder bore is acceptable; it will burn off during the first engine start.

4. Turn the crankshaft through at least two complete revolutions to remove the cylinder preservation oil from the cylinders.
5. Catch the cylinder preservation oil draining out of the lower spark plug holes.

NOTE: If corrosion or abnormal conditions are discovered during borescope, contact the supplier of the engine (for engines purchased from TCM, contact TCM's Service Department ("TCM Contact Information" in Chapter 1)).

6. Inspect the cylinder bores with a borescope for rust and contamination.
7. Remove the oil sump drain plug and drain the remaining cylinder preservation oil from the oil sump. The drain plug location is shown in the Installation Drawings.
8. Reinstall the drain plug with a new crush washer; torque the drain plug per Appendix B and safety wire the drain plug per standard practices.
9. On new, rebuilt, or overhauled engines acquired from TCM, place a catch basin underneath the fuel pump. Remove the shipping cap from the fuel pump inlet fitting. Disconnect the fuel pump outlet hose from the outlet fitting. Allow the preservative fluid to drain from the fuel pump and hose, and then reconnect the outlet hose. Reinstall the shipping cap.
10. Inspect the engine for any discrepancies or damage prior to installing it in the airframe. Do not install a damaged engine.

NOTE: Remove the turbochargers only if necessary to clear the engine compartment during engine installation. Otherwise, proceed to step 12.

11. If engine compartment clearance is required, remove turbochargers:
  - a. Disconnect and plug the hoses from the wastegate actuator and turbochargers. Refer to "Installation Drawings" in this chapter.
  - b. Install caps on the wastegate and turbocharger fittings to prevent contamination from foreign matter/debris.
  - c. Remove the clamp from the left turbocharger tailpipe.
  - d. Remove the tie rod from the right side of the turbo bypass assembly.
  - e. Remove the following as one assembly:
    - 1) Left tailpipe



- 2) Wastegate
- 3) Actuator
- 4) Bypass
- f. Remove the two nuts and bolts from the turbocharger mounting bracket.
- g. Remove the four nuts from the turbocharger mounting flange.
- h. Remove both turbochargers.

**WARNING**

**Oil pressure is applied to the face of the accessory drive pads. If gasket or accessory covers are not properly installed and torqued according to Appendix B oil leakage will occur.**

12. Remove the shipping plate from the propeller governor pad forward of the #6 cylinder.
  - a. Lubricate the governor shaft splines with engine oil.

*CAUTION: Align governor drive gear spline and ensure the governor is fully seated to the crankcase prior to installing the attaching hardware. Forcing the drive gear over the camshaft will require engine disassembly*

- b. Install a new gasket and the propeller governor control with washers, new lock washers, and nuts. Torque the hardware according to airframe manufacturer's specification

NOTE: Optional accessories such as hydraulic pumps, vacuum pumps, etc. may be installed in the accessory drive pads located on the upper rear portion of the crankcase. Remove the accessory drive covers and install new gaskets. Install accessories in accordance with the airframe manufacturer's instructions.

13. In accordance with the airframe manufacturer's instructions, install all airframe manufacturer-required components, including:
  - a. Cooling baffles
  - b. Hoses
  - c. Fittings
  - d. Brackets
  - e. Ground straps
  - f. Hydraulic or vacuum pumps
  - g. Exhaust system
  - h. Other airframe manufacturer required item(s)

14. Install the engine as instructed in the "Engine Installation" section of this chapter.

### 4-3.3. Installation Sequence

1. Refer to the Engine Installation Drawings for engine dimensions and clearances. Install the engine in the order listed below. Repair discrepancies as they are discovered. Detailed repair procedures are presented in TCM's Maintenance and Overhaul Manual (M-18).
  - a. Attach a hoist to the engine lifting eyes located at the top of the crankcase backbone. Refer to the Engine Installation Drawings, in this section for the location of the lifting eyes.
  - b. Take up slack on the hoist prior to loosening the engine mount bolts; then remove the bolts from the shipping shock mounts.
  - c. Maneuver the engine into position and secure the engine on the airframe mount points

#### **WARNING**

**Oil pressure is applied to the face of the accessory drive pads. If gasket or accessory covers are not properly installed and torqued to the settings specified in Appendix B, oil leakage will occur.**

*CAUTION: Do not allow chains to become entangled on the engine or its hardware. Be sure the area is clear when lifting the engine. Do not allow the front, rear, sides, or bottom of the engine to strike any obstructions, as the extreme weight may damage the engine or its components.*

2. Connect the fuel pump according to airframe manufacturer's instructions.
3. If removed to facilitate installation, install the turbocharger components as directed in the section "Turbocharger Component Installation" in this chapter.
4. Connect Starter Wiring
  - a. Use airframe manufacturer's instructions to connect engine wiring harness starter wire to the post on the side of the starter.
  - b. Install washer and nut
  - c. Torque nut according the airframe manufacture specifications.
5. Connect Alternator Wiring Harness
  - a. Use airframe manufacturer/s wiring diagram and instructions to connect the alternator wiring.
  - b. Install a washer and nut on each connection.
  - c. Torque nuts according the airframe manufacture specifications.
6. Service the engine to the specified oil sump capacity according to instruction in "Engine Oil Servicing" in Chapter 5.
7. Turn the Ignition Switch to the OFF position.





**WARNING**

**Do not install the ignition harness “B” nuts on the spark plugs until the P-leads are connected and propeller installation is complete and the ignition system operational checkout is complete. Failure to comply can result in bodily injury when the propeller is rotated during installation.**

8. Install the propeller according to the airframe and propeller manufacturer’s instructions.

*CAUTION: Verify the ignition switch disables the magneto with a timing light before installing the spark plugs and ignition harness.*

9. Connect the magneto P-leads from the ignition switch to the “switch” terminals on each magneto according to the airframe manufacturer’s instructions and check the switch for proper operation.
10. Perform the preoiling procedure as described in the “Engine Preoiling” section of this chapter. If Preoiling Method 2 is selected, install the spark plugs after preoiling.
11. If the magnetos were loosened or rotated during engine installation, adjust them according to the “Magneto to Engine Timing” instructions in Chapter 5.
12. Install remaining aircraft accessories, equipment, or instrumentation according to the aircraft manufacturer’s instructions.
13. Purge the fuel injection system after installation according to the instructions in section 4-3.3.4, “Fuel Injection System Purge.”
14. Perform the steps in section 4-3.4, “Installation Inspection.”
15. Inspect the engine for any debris, discrepancies, or damage. Correct any discrepancies.

**WARNING**

**Do not operate the engine unless all of the following conditions are met and verified: All hardware, spark plugs, gaskets, seals are in place and torqued. (If they are not, oil leaks can occur) The oil sump is properly filled to the specified capacity with oil.**

16. Perform an “Engine Operational Check” according to Chapter 5.

### 4-3.3.1. Turbocharger Component Installation

Install the following turbocharger components if they were removed to facilitate engine installation:

- Both turbochargers
  - Left tailpipe/wastegate actuator/bypass assembly
  - Four nuts on the turbocharger mounting flange
  - Two nuts and bolts on the turbocharger mounting bracket
  - Torque fastening hardware per Appendix B in this manual
1. Install the turbocharger support bracket (29 and 30) (Figure 4-1) with the respective turbocharger (24) mounted on the turbo mount brackets; loosely install the hardware (31, 32 and 33); hardware will be torqued later in this procedure.
  2. Install the gasket (23) between the risers on the turbochargers (24). Hand tighten the fastening bolt (26), washer (27) and lock nut (28). This hardware will be torqued later in this procedure.
  3. Install the fittings (38 and 40), plug (22) and O-rings (39 and 41) on the waste gate (18).
  4. Install the waste gate (18) between the tailpipe (14) and transition (9) sandwiched between two gaskets (17) (one gasket on top of the waste gate and one on tailpipe flange using eight sets of fastening hardware (19, 20 and 21). This hardware will be torqued later in this procedure.
  5. Place a clamp (16) halfway on each turbine exhaust flange.
  6. Slide the transition (7) and the crossover pipe (8) together to form the bypass assembly and onto the rear ports of the exhaust tees (5 and 6).
  7. Push the tailpipe (14) exhaust flange against the left side turbine exhaust flange and place a new clamp (16) in the center, squarely over both flanges. Initially torque the clamp nut to  $\frac{1}{2}$  the final value for V-band clamps specified in Appendix B. Lightly tap the outer edge of the clamp to distribute the load. Align the flanges and do a final torque of the clamp to Appendix B specifications.
  8. Push the tailpipe exhaust flange (15) (or heater (15b) on some TSIO-550-C and E models) against the right side turbine exhaust flange and place a clamp (16) in the center, squarely over both flanges. Initially torque the clamp nut to  $\frac{1}{2}$  the final value for V-band clamps specified in Appendix B. Lightly tap the outer edge of the clamp to distribute the load. Align the flanges and do a final torque of the clamp to Appendix B specifications.
  9. Torque the attaching hardware in the following sequence per Appendix B: 31, 33, 26, 28, 19 and 21.
  10. Secure the bypass assembly (8 and 9) to the exhaust tees (5 and 6) using the tie rod (11), bushing (10), bolt (12) and nut (13). Torque the bolt according to Appendix B.



*CAUTION: the exhaust system requires freedom of movement for proper operation after installation. Ensure the bushing (10) is properly installed in the tie rod to allow expansion and the exhaust system parts have adequate clearance from surrounding objects after installation.*

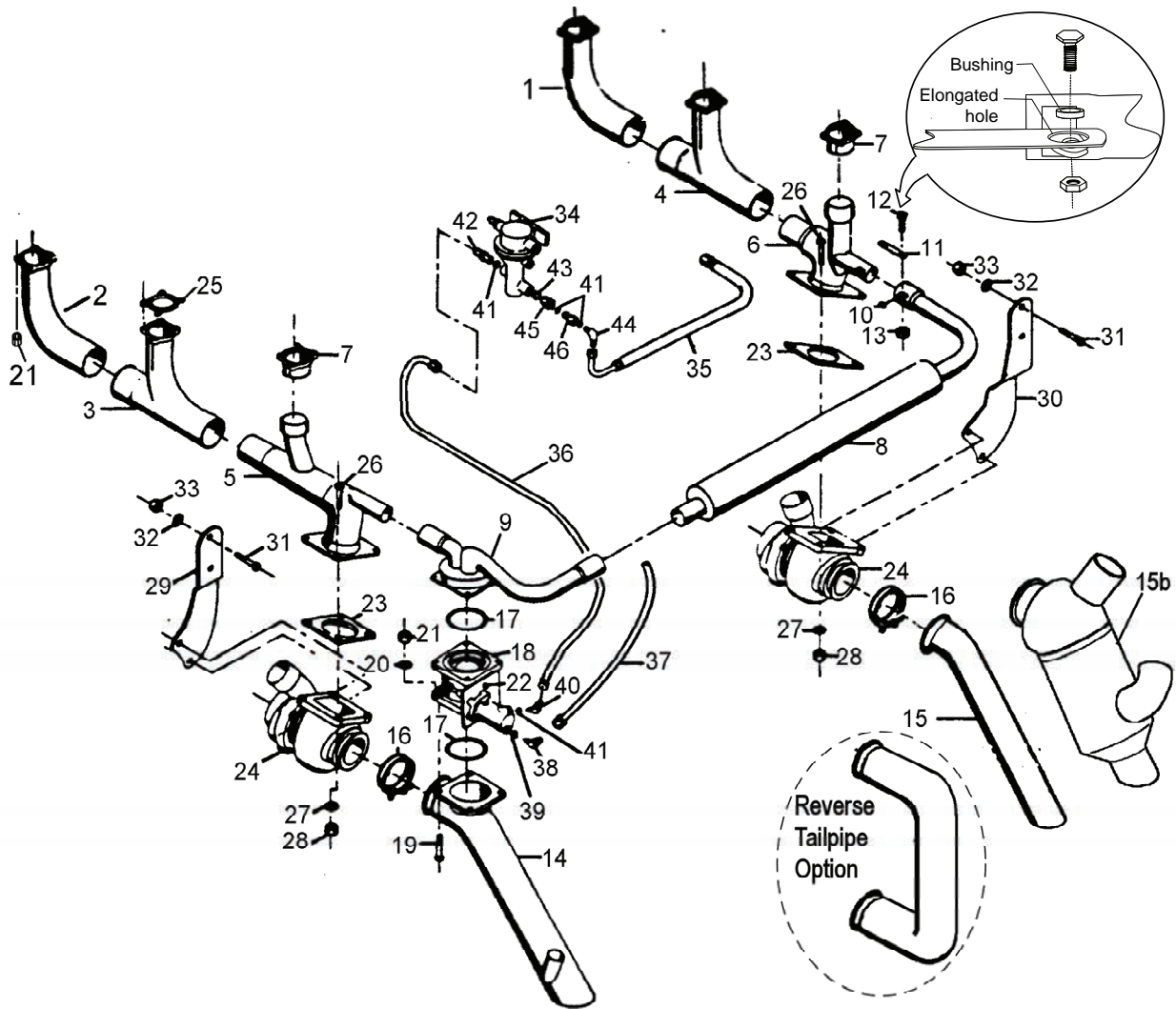

**Figure 4-1. TSIO-550 Exhaust System**

|    |            |     |                         |    |                    |    |                 |
|----|------------|-----|-------------------------|----|--------------------|----|-----------------|
| 1  | Elbow      | 13  | Nut                     | 23 | Gasket             | 35 | Hose            |
| 2  | Elbow      | 14  | Tailpipe                | 24 | Turbocharger Assy. | 36 | Hose            |
| 3  | Tee        | 15  | Tailpipe                | 25 | Gasket             | 37 | Hose            |
| 4  | Tee        | --- | Reverse Tailpipe Option | 26 | Bolt               | 38 | Fitting         |
| 5  | Transition | 15b | Heater                  | 27 | Washer             | 39 | O-ring          |
| 6  | Transition | 16  | V-band Clamp            | 28 | Lock Nut           | 40 | Elbow Fitting   |
| 7  | Riser      | 17  | Gasket                  | 29 | Bracket            | 41 | O-ring          |
| 8  | Crossover  | 18  | Waste Gate              | 30 | Bracket            | 42 | Adapter Fitting |
| 9  | Transition | 19  | Bolt                    | 31 | Screw              | 43 | O-ring          |
| 10 | Bushing    | 20  | Washer                  | 32 | Washer             | 44 | Elbow Fitting   |
| 11 | Tie Rod    | 21  | Lock Nut                | 33 | Lock Nut           | 45 | Reducer         |
| 12 | Bolt       | 22  | Plug                    | 34 | Controller         | 46 | O-ring          |

11. Assemble and attach the hose (15) (Figure 4-2) to the right oil reservoir (9) from the connecting tee (18).
12. Assemble and attach the hose (19) to the left oil reservoir (8) from connecting tee (18).

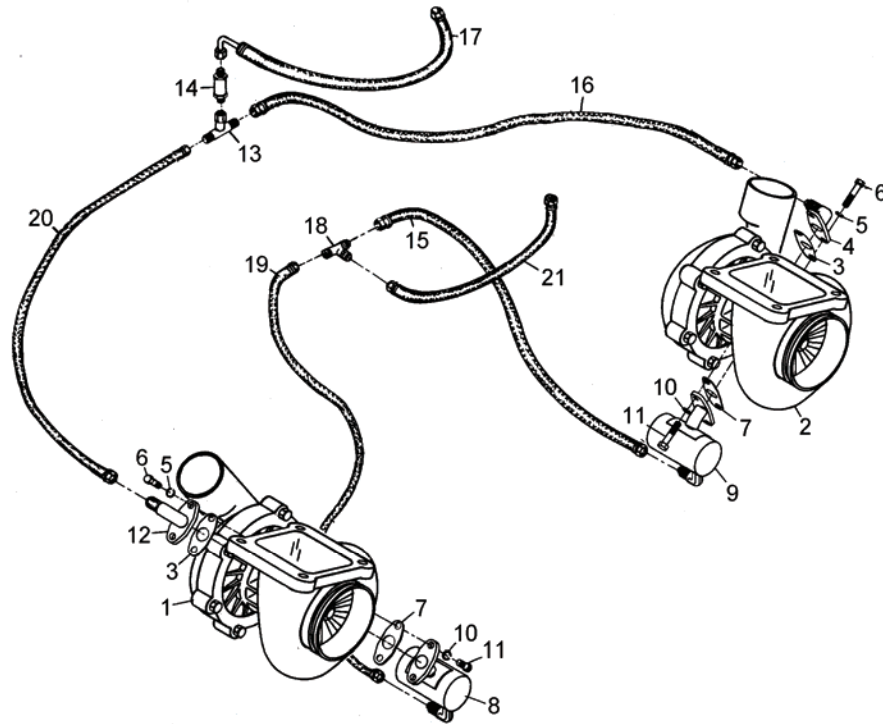

**Figure 4-2. TSIO-550 Turbochargers**

|   |                    |    |                     |    |      |
|---|--------------------|----|---------------------|----|------|
| 1 | Left Turbocharger  | 8  | Right Oil Reservoir | 15 | Hose |
| 2 | Right Turbocharger | 9  | Left Oil Reservoir  | 16 | Hose |
| 3 | Gasket             | 10 | Lock Washer         | 17 | Hose |
| 4 | Adapter            | 11 | Bolt                | 18 | Tee  |
| 5 | Lock Washer        | 12 | Adapter             | 19 | Hose |
| 6 | Bolt               | 13 | Tee                 | 20 | Hose |
| 7 | Gasket             | 14 | Check Valve         | 21 | Hose |

*CAUTION: The tailpipe breather hose must be of suitable material to withstand exhaust temperatures.*

13. Install a hose clamp (80) on the oil separator vent line (81) (Figure 4-3). Connect the hose to the left tailpipe and tighten the clamp. Torque the clamp according to Appendix B.

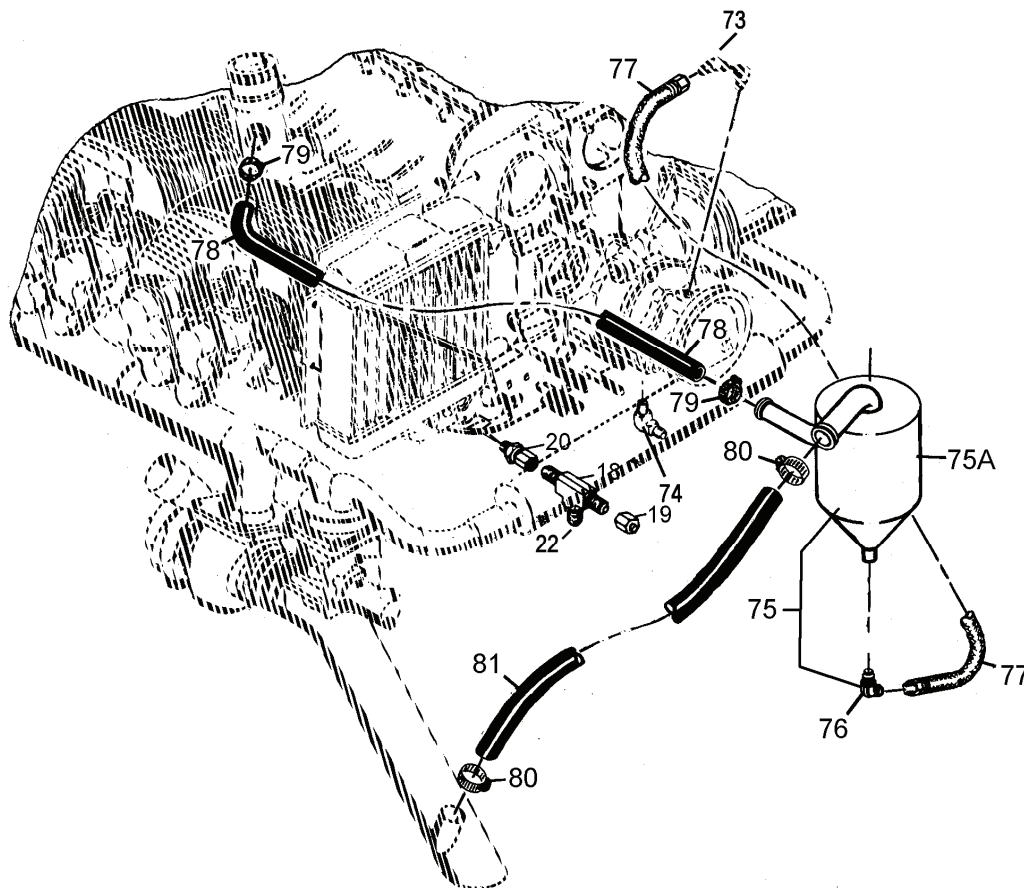

Figure 4-3. Crankcase Ventilation Hose Routing

#### 4-3.3.2. Propeller Installation

Consult the airframe manufacturer's installation instruction for specific propeller installation steps.

### 4-3.3.3. Engine Pre-oiling

Engine preoiling must be accomplished prior to engine start-up after engine installation or overhaul/assembly. There are two pre-oiling methods:

NOTE: If engine cylinders were installed or the engine is new or overhauled, follow Pre-oiling Method 1.

#### 4-3.3.3.1. Pre-oiling Method 1

1. Install and torque the spark plugs and ignition lead wires as instructed in “Spark Plug Installation” and “Ignition Harness Installation” in Chapter 5.
2. Verify the lubrication lines, fittings, hoses, screens, and filters are in place prior to pre-oiling.
3. Obtain a 1-gallon capacity bladder-type pressure pot with an output pressure of 50 psi (not to exceed 60 psi).
4. Connect the pre-oiler supply hose to the engine oil pressure output (fitting).
5. Disconnect the safety wire from the engine oil filter and loosen (do not remove) the oil filter from the oil filter adapter.
6. Open the pre-oiler valve. Watch the seam of the oil filter for evidence of oil flow. Depending upon the oil temperature, it may take as long as 20 minutes to see an indication of oil flow.
7. Close the pre-oiler valve.
8. After oil flow confirmation, torque the oil filter according to Appendix B and safety wire the filter according to the instructions in Appendix C.
9. Disconnect the pre-oiler supply hose and cap; connect the engine oil pressure output to the oil pressure gauge connection (fitting).

#### **WARNING**

**Do not operate this engine unless the oil is serviced to the proper level.**

10. Check the oil level in the sump using the oil gauge rod (dip stick). Refer to “Engine Oil Servicing” in Chapter 5.



#### **4-3.3.3.2. Pre-oiling Method 2**

1. If it has not already been done, service the oil level; refer to the sections “Engine Oil Servicing” in Chapter 5.
2. Turn the engine using the starter. The typical cycle is 30 seconds with the starter on, followed by 3 to 5 minutes to allow the starter to cool.
3. Spin the engine for a maximum total duration not to exceed 80 seconds or until the oil pressure gauge shows oil indication.
4. Install and torque the spark plugs and ignition lead wires as instructed in “Spark Plug Installation” and Ignition Harness Installation” in Chapter 5.
5. Check the oil level in the sump using the oil gauge rod (dip stick). Refer to “Engine Oil Servicing” in Chapter 5.

**WARNING**

**Do not operate this engine unless the oil is serviced to the proper level.**

#### 4-3.3.4. Fuel Injection System Purge

Prior to shipping, the fuel injection system was preserved with MIL-PRF-6081D Grade 1010. The preservative fluid was drained during “Engine Preparation for Installation.” Flushing the system with aircraft fuel will complete the purge, ease engine starting and provide more accurate response during fuel system adjustments.

1. Disconnect the fuel supply line at the inlet to the fuel manifold valve.
2. Connect a length of the appropriate size hose to the disconnected fuel manifold supply hose using an AN union fitting and secure the end of the hose in a properly grounded Type 1 flammable fluid container.

*CAUTION: Ensure the magneto switch is in the OFF position and clear the rotational arc of the propeller before proceeding.*

3. Have an assistant turn the aircraft master switch on.
4. Adjust the mixture control to full rich and the throttle to full open.
5. Place the aircraft boost pump in the on position for approximately one minute to purge the preservative fluid from the fuel system.
6. Turn the aircraft boost pump and master switch to the off position.
7. Close the mixture and throttle.
8. Remove the extra length of hose and union installed in step 2 from the fuel manifold valve supply hose.
9. Connect the fuel manifold valve fuel supply hose to the inlet fitting on the manifold valve and torque the fuel hose “B” nut to the value specified in Appendix B.

*NOTE: Place approved containers at the induction system drain locations to collect fuel as it is drained overboard during the following procedure.*

10. Have an assistant turn the aircraft master switch to the ON position.
11. With the mixture control in FULL RICH and the Throttle ¼ OPEN, turn the aircraft boost pump to the ON position.
12. Visually inspect all fuel injection system lines, hoses and fitting for evidence of fuel leakage.
13. Place the mixture control to IDLE CUT-OFF and CLOSE the THROTTLE.
14. Turn the aircraft fuel boost pump OFF.
15. Turn the aircraft Master Power Switch OFF.
16. Correct any discrepancies noted.
17. Dispose of the fuel/oil mixture in accordance with Federal and State Hazardous Material Regulations.





#### **4-3.4. Installation Inspection**

An Operational Inspection and a normal preflight ground run-up in accordance with the aircraft POH and Airplane Flight Manual (AFM) must be performed before the aircraft is approved by an airframe and powerplant mechanic for a Flight Check. The Flight Check is required to ensure the engine and aircraft meet all of the manufacturer's performance and operational specifications prior to releasing the aircraft for normal service.

Inspect the listed areas before attempting an engine start:

##### **1. Engine Mounts**

- a. Engine mounts are free of cracks, corrosion or damage.
- b. Engine and airframe mounting points are properly aligned and torqued as specified by the aircraft manufacturer.
- c. Sufficient clearance exists between the engine (including any customer furnished items attached to the engine) and the aircraft/engine mount and cowling.
- d. All engine to airframe connections are flexible and correctly supported to prevent vibration transmission, chafing and breakage.

##### **2. Engine Fuel System**

- a. Fuel supply lines, valves, filters and fittings are sufficient size to provide adequate fuel flow for maximum power plus fuel return with running auxiliary fuel pump.
- b. Fuel System has provisions for water and sediment isolation and drainage at its lowest points in normal ground attitude and that the drains are accessible.
- c. Fuel lines and hoses are routed and supported to prevent exposure to excessive temperature.
- d. Fuel lines and hoses are routed with no unnecessary bends, fittings or elevation changes.
- e. Fuel lines and hoses are per TSO or fabricated from fire resistant material.

##### **3. Exhaust System**

- a. Sufficient clearance or heat shielding between exhaust components and spark plugs, plug leads, mount isolators, induction system, engine controls, fuel system and heat sensitive airframe components.
- b. Adequate support for tail pipes, heat exchangers and mufflers.
- c. Flexibility provided for thermal expansion and engine movement.
- d. Tail pipe exit is located away from fuel and oil drains to eliminate ignition.

##### **4. Lubrication System**

- a. Oil cooler baffles are installed to maximize oil cooler efficiency.
- b. Oil temperature and pressure monitoring sensors are installed correctly.
- c. External oil lines to the engine are correctly routed and supported.



- d. Oil separator used on crankcase breather has oil return line free from low trap points or other areas where sludge deposits can stop drainage.
  - e. Crankcase breather is routed overboard, free of the airframe, will not create suction or pressure and is protected from freezing.
  - f. Oil screens and oil filters are accessible for service with minimal oil spillage.
  - g. Oil gauge rod is correctly installed and supported.
5. Air Induction System
- a. Induction air filter is correctly installed.
  - b. Alternate air system door is connected, operates smoothly and seals properly in the closed position.
  - c. Flexible joints in the induction system are properly connected between airframe and engine.
  - d. Induction system drain check valves are properly installed and function correctly.
  - e. Induction system installation will not interfere with access to engine adjustments.
6. Electrical System
- a. Engine is securely grounded to the airframe or directly grounded to the negative battery terminal with the adequate size ground wire.
  - b. Exposed positive connections are protected from accidental shorting with terminal boots or are enclosed in a protective box.
  - c. Magneto switches are independently grounded to the engine with shielded wire.
  - d. Magneto ground leads are routed through separate firewall connectors.
  - e. Electrical wire installations and instrumentation wiring harnesses are bundled neatly and have no unnecessary looping or kinking.
  - f. Engine electrical lead length sufficiently permits engine movement in all extremes without breaking wires.
  - g. Electrical wires are properly located and protected to prevent chafing, exposure to fuel, oil, heat radiation, moisture and all moving parts.
  - h. Wiring between battery, starter contact and starter are of sufficient size and as short as possible to prevent voltage drop.
7. Air Cooling Baffles And Cowling System
- a. Fire proof and gas sealed firewall is intact and has sustained no damage during engine installation.
  - b. Replaced all baffles that are not sufficient to accommodate the relative air movement between the individual cylinders.
  - c. Baffles are not cracked and all fasteners are intact.
  - d. Baffles make proper seals between engine and closed cowling.
  - e. Baffle seals are installed and supported to provide adequate engine movement and maintain seal integrity within the cowl.



- f. Baffles and fasteners will not affect the integrity of the engine.
  - g. Ducts, tubes, or other components do not interfere with the free flow of cooling air in or out of the cowling.
  - h. Temperature probes are properly located to accurately report cylinder head, turbine inlet, and exhaust gas temperatures.
8. Engine Controls
- a. Controls are installed properly and accommodate engine movement without binding or change of adjustment.
  - b. Controls operate smoothly through full range of travel at control and controlled device.
  - c. Side loads on engine or accessory control shafts are not excessive.
  - d. Control function and direction of movement is clearly marked
  - e. Controls are installed to engine levers to minimize the possibility of engine control separation.
  - f. Friction lock for primary engine control is effective without using excessive force.
9. Engine Instrumentation
- a. Engine instrumentation gauges are properly calibrated and function properly.
  - b. Connections between engine and instruments are installed for accessibility and are protected from chafing, heat and damage from engine motion.
10. Accessory Installation
- a. Accessories are installed with proper gasket and properly torqued.
  - b. Accessories are the correct model to operate in the speed range provided by the engine drive or accessory drive.

### 4-3.5. Preflight and Run-up

#### **WARNING**

Although the fuel system was adjusted on the test stand, the fuel system must be checked and adjusted in accordance with the “Engine Operational Check” section of Chapter 5 of this manual and current service documents when the engine is installed in the airframe to ensure proper operation. All discrepancies must be corrected prior to release for flight.

TSIO-550 Permold Series engines are not designed nor approved for continuous negative or zero gravity operation. Engine Mount loads shall not exceed FAR 23 utility category load factors.

*CAUTION: Adhere to the Operating Limits specified in Chapter 2 during engine operation.*

NOTE: New and factory rebuilt engines complete an acceptance test prior to shipment on a test stand. The engine will require an operational test and a flight check to complete engine break-in. After installation, avoid prolonged ground operation at high power.

1. Perform the “Engine Operational Check” located in Chapter 5 of this manual.
2. Perform a “Flight Check” located in Chapter 7.



### 4-4. TSIO-550 Installation Drawings

Installation drawings are provided to assist the airframe manufacturer determine appropriate fittings and fasteners for airframe interconnect and determine fit and limit requirements for engine compartment. Slight variations between the basic TSIO-550 B and subsequent engine models require separate engine installations. Pay particular attention to the model depicted when referencing drawings for engine installation requirements.

#### 4-4.1. TSIO-550 Common Installation Drawings

Exhaust port and propeller dimensions are identical for the TSIO-550 series engines. Specific engine model dimensions follow the common installation drawings.

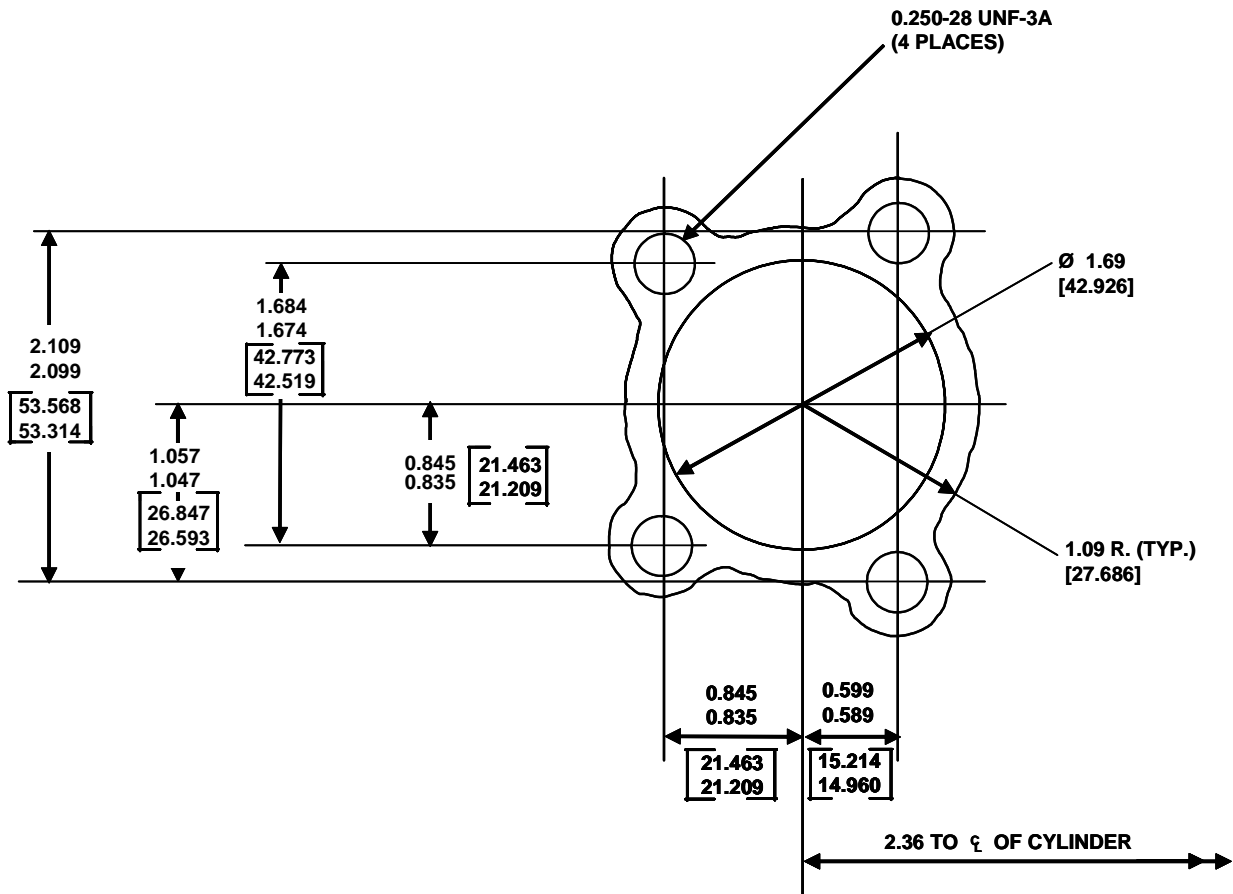

Figure 4-4. Exhaust Port Dimensions

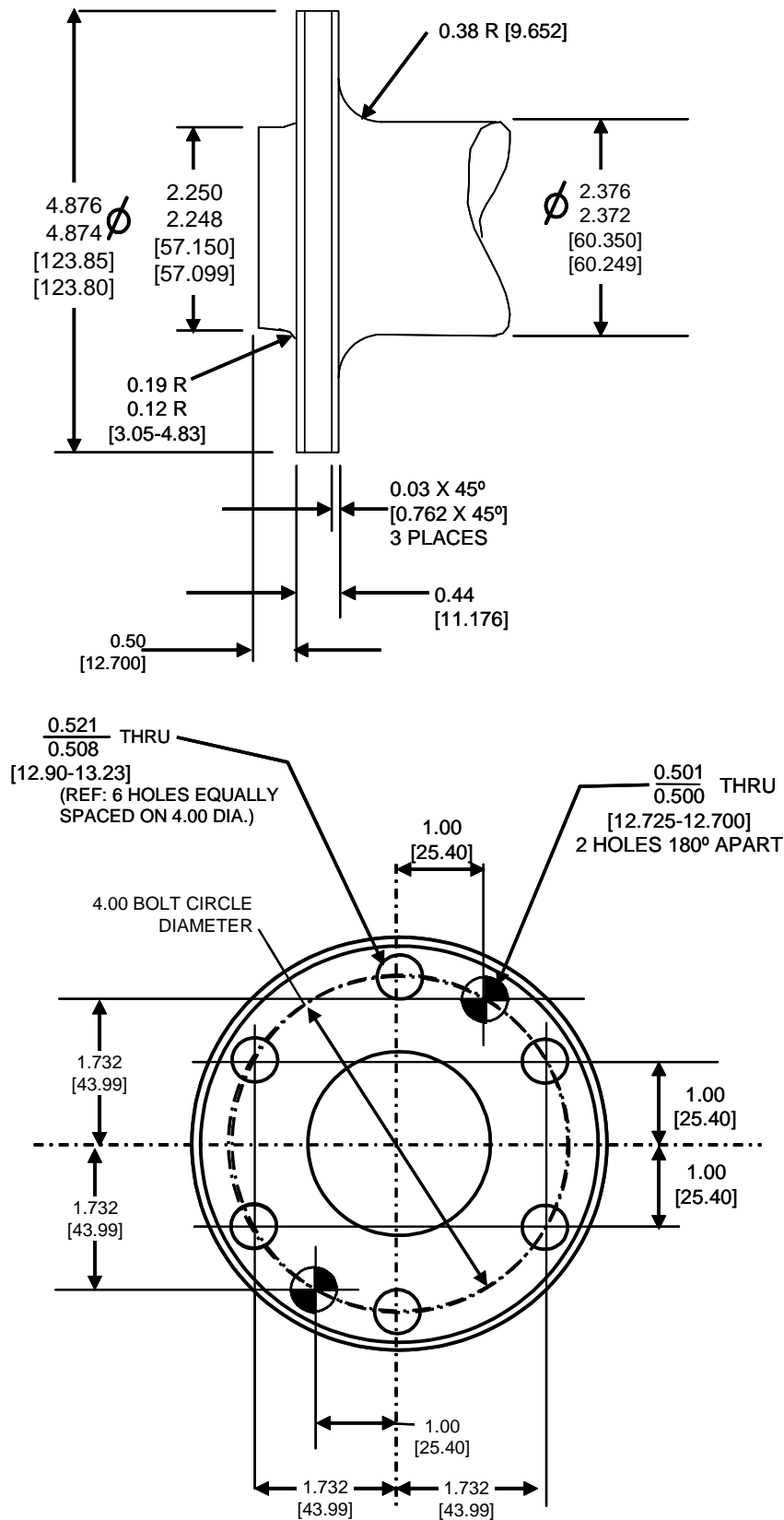

Figure 4-5. Propeller Flange Dimensions



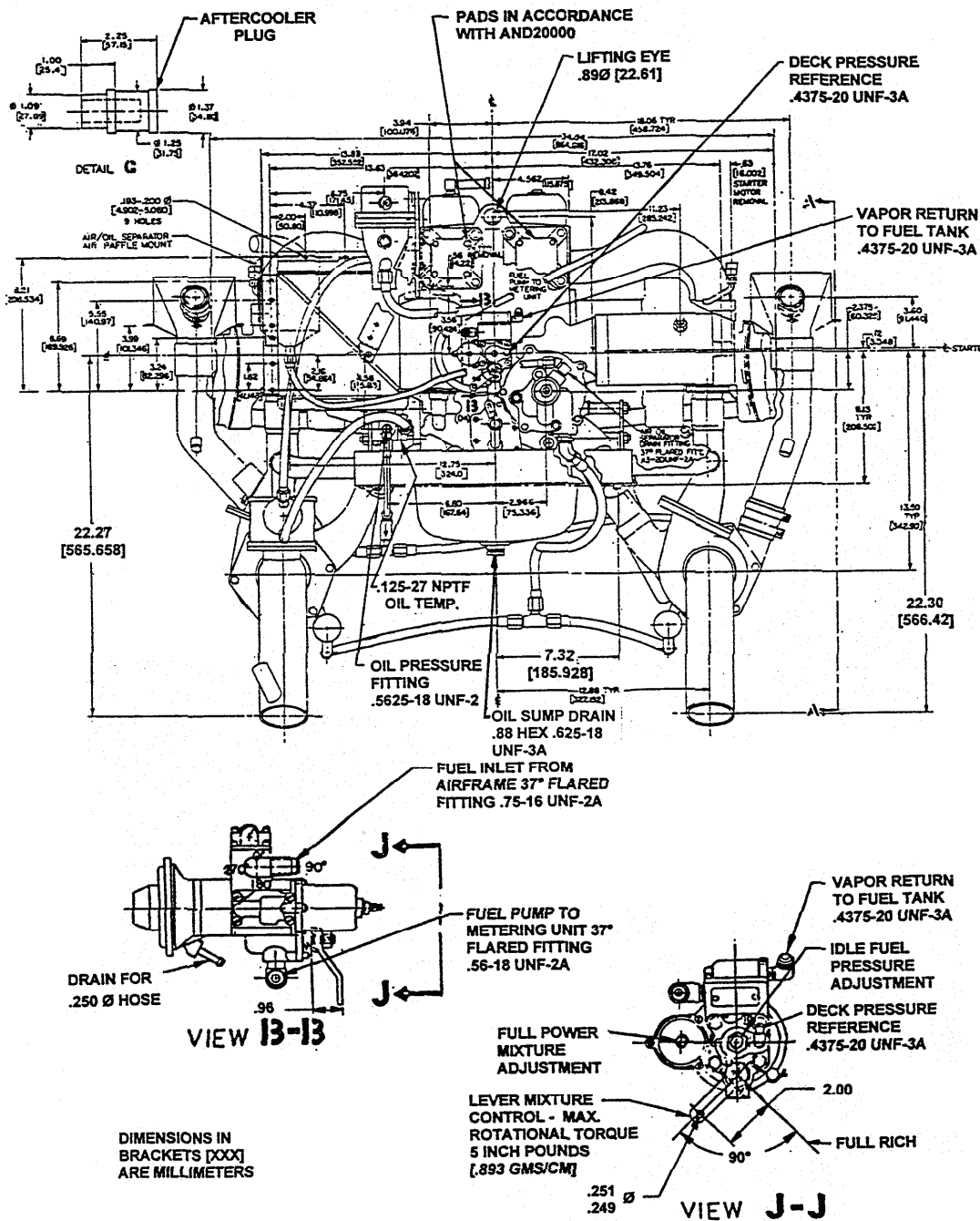

Figure 4-7. TSIO-550-B Rear View



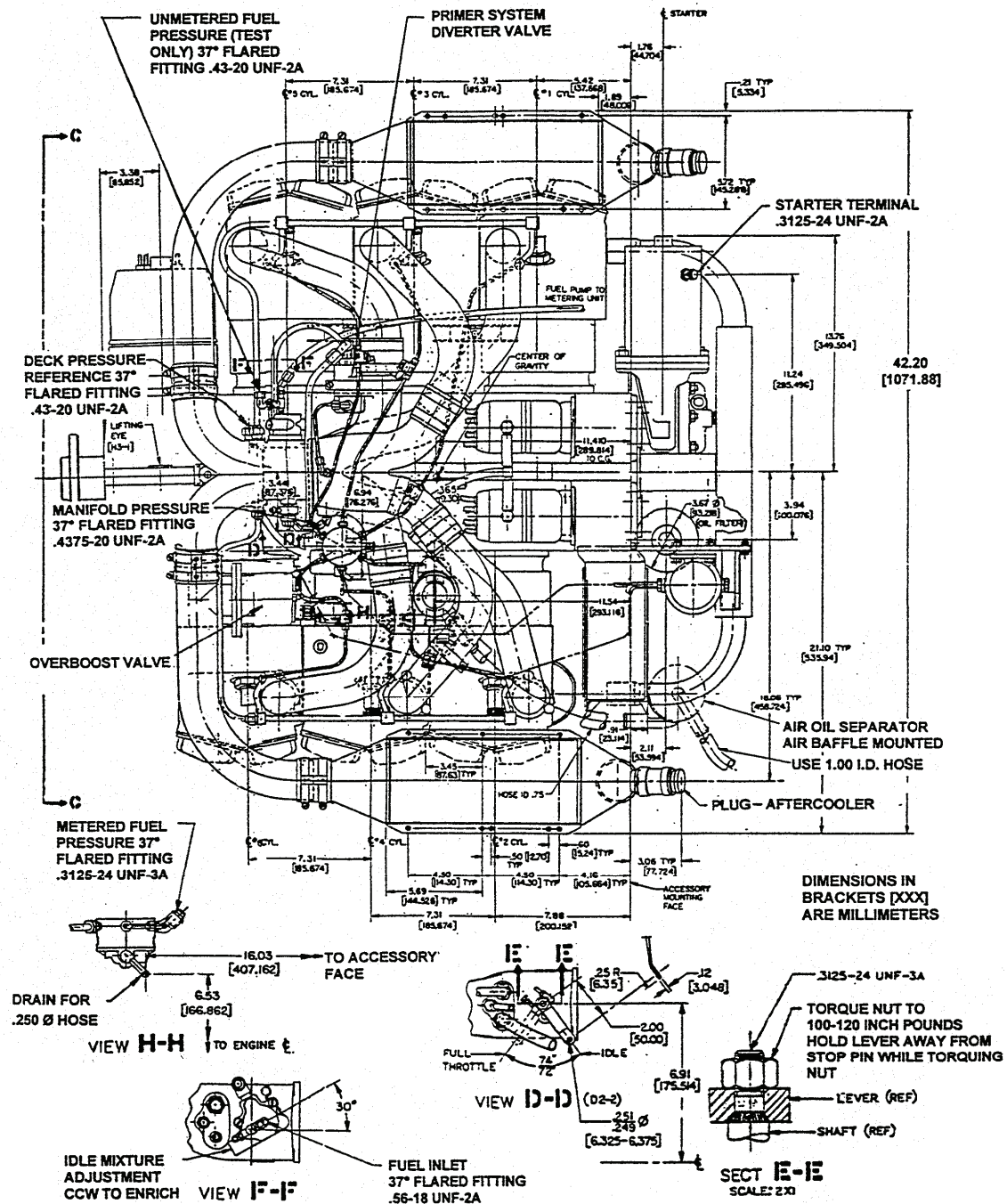

Figure 4-8. TSIO-550-B Top View



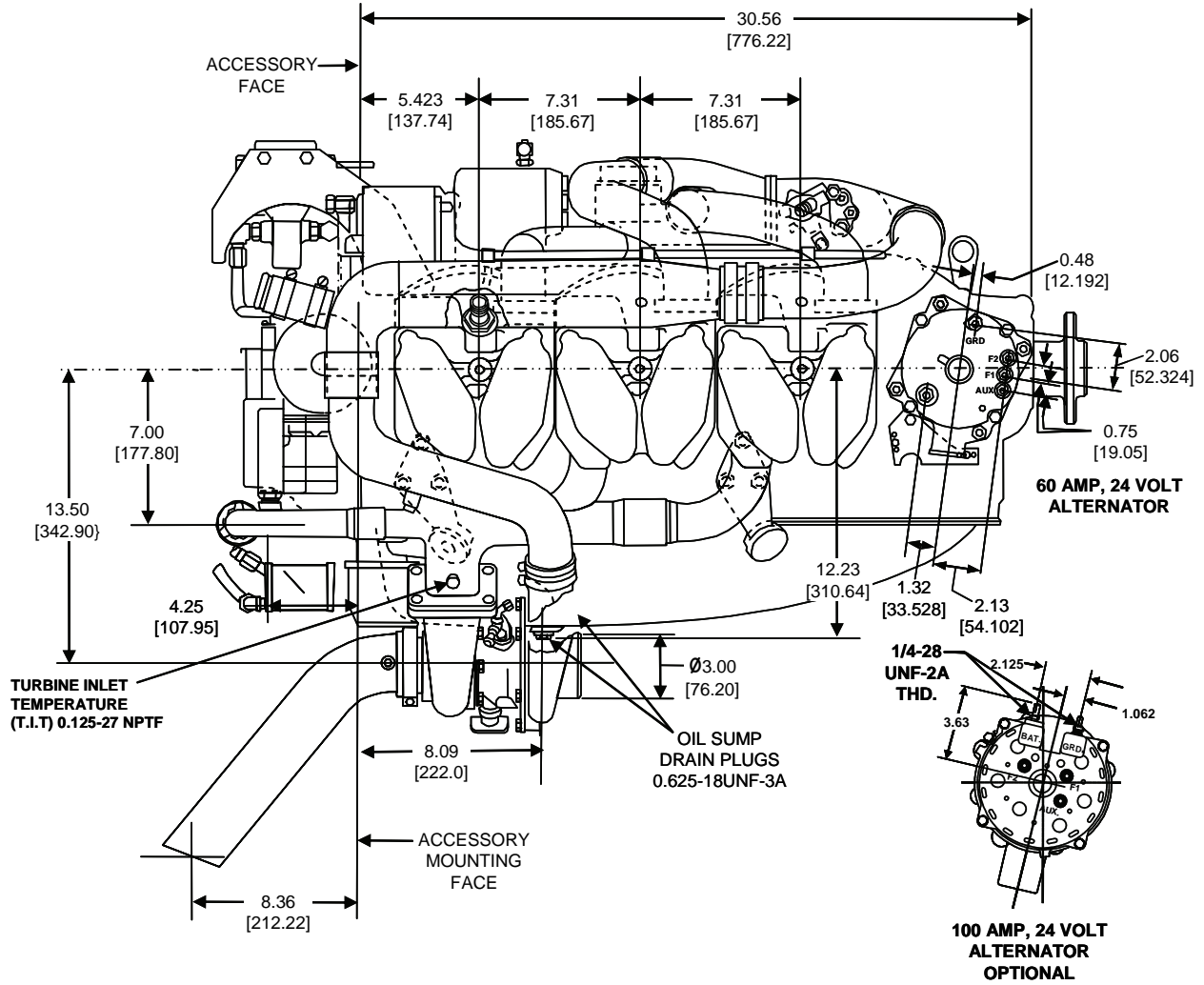

Figure 4-10. TSIO-550-B Right Side View



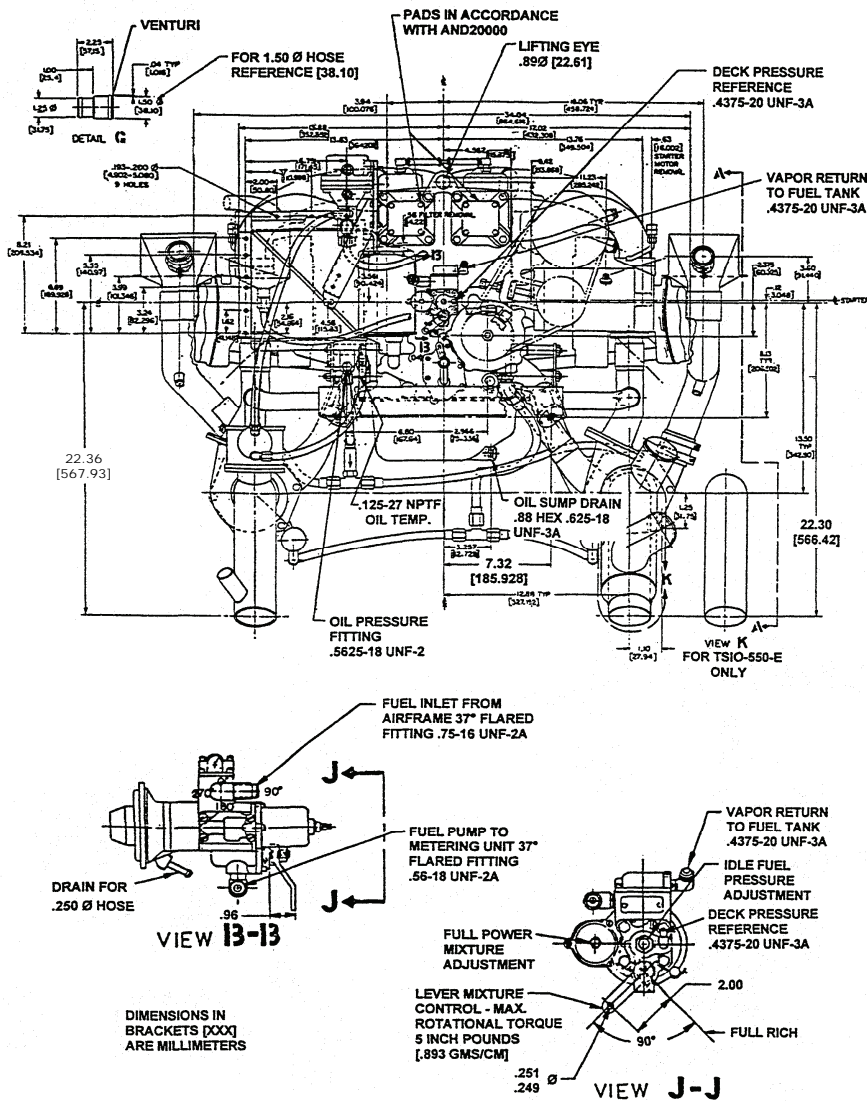

Figure 4-12. TSIO-550-C & E Rear View

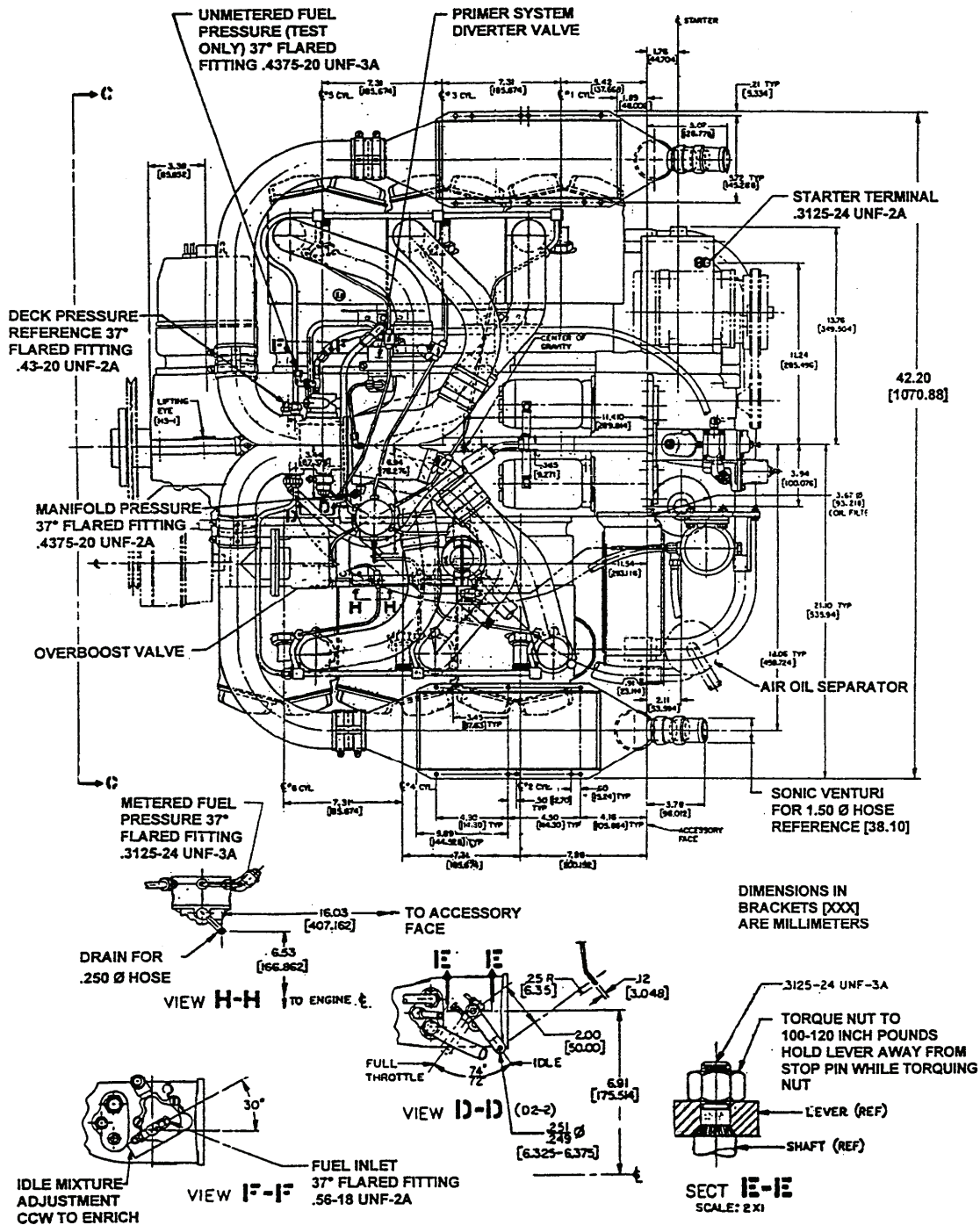

Figure 4-13. TSIO-550-C & E Top View



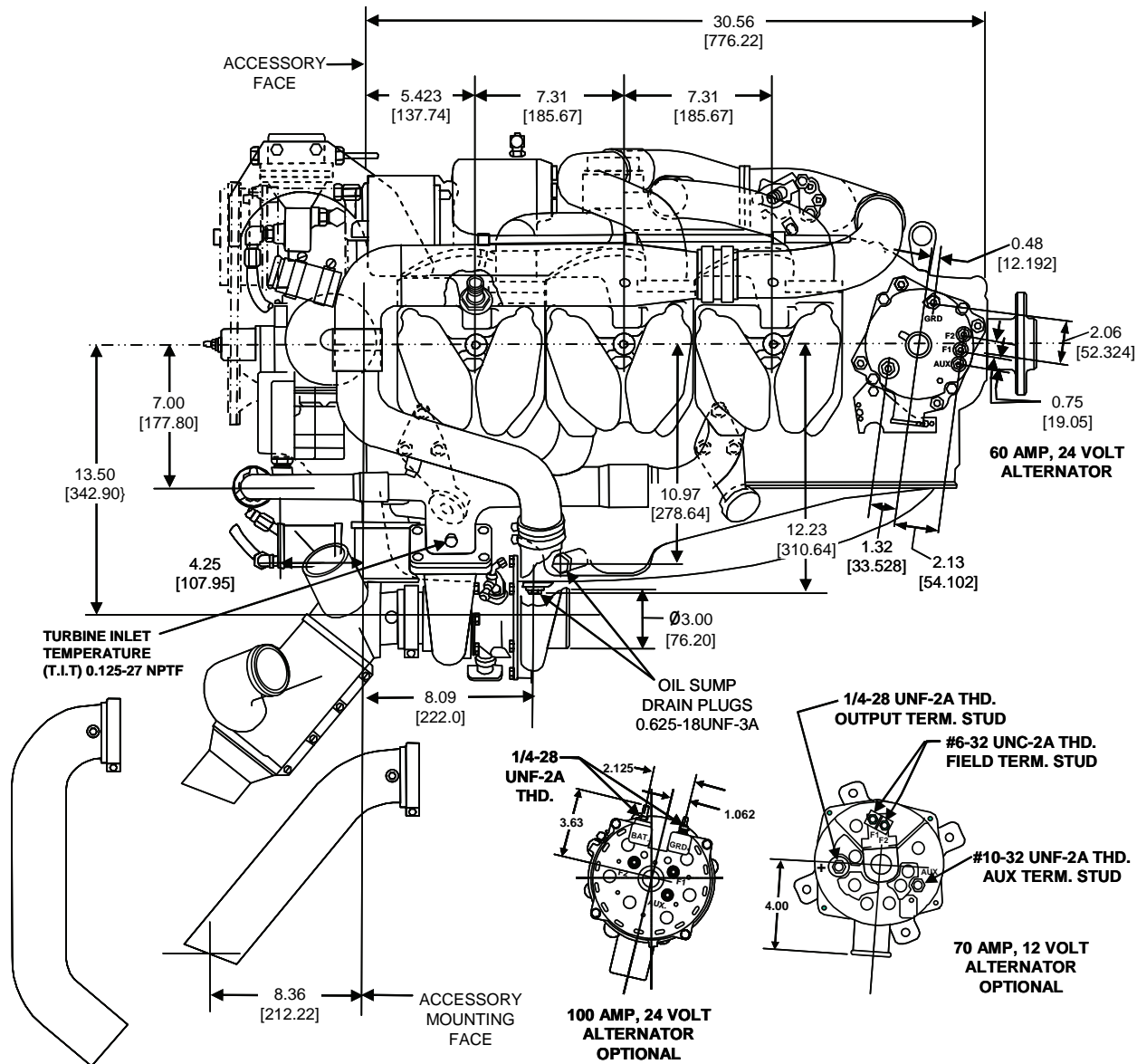

Figure 4-15. TSIO-550-C & E Right Side





### 4-4.4. TSIO-550-G Installation Drawings

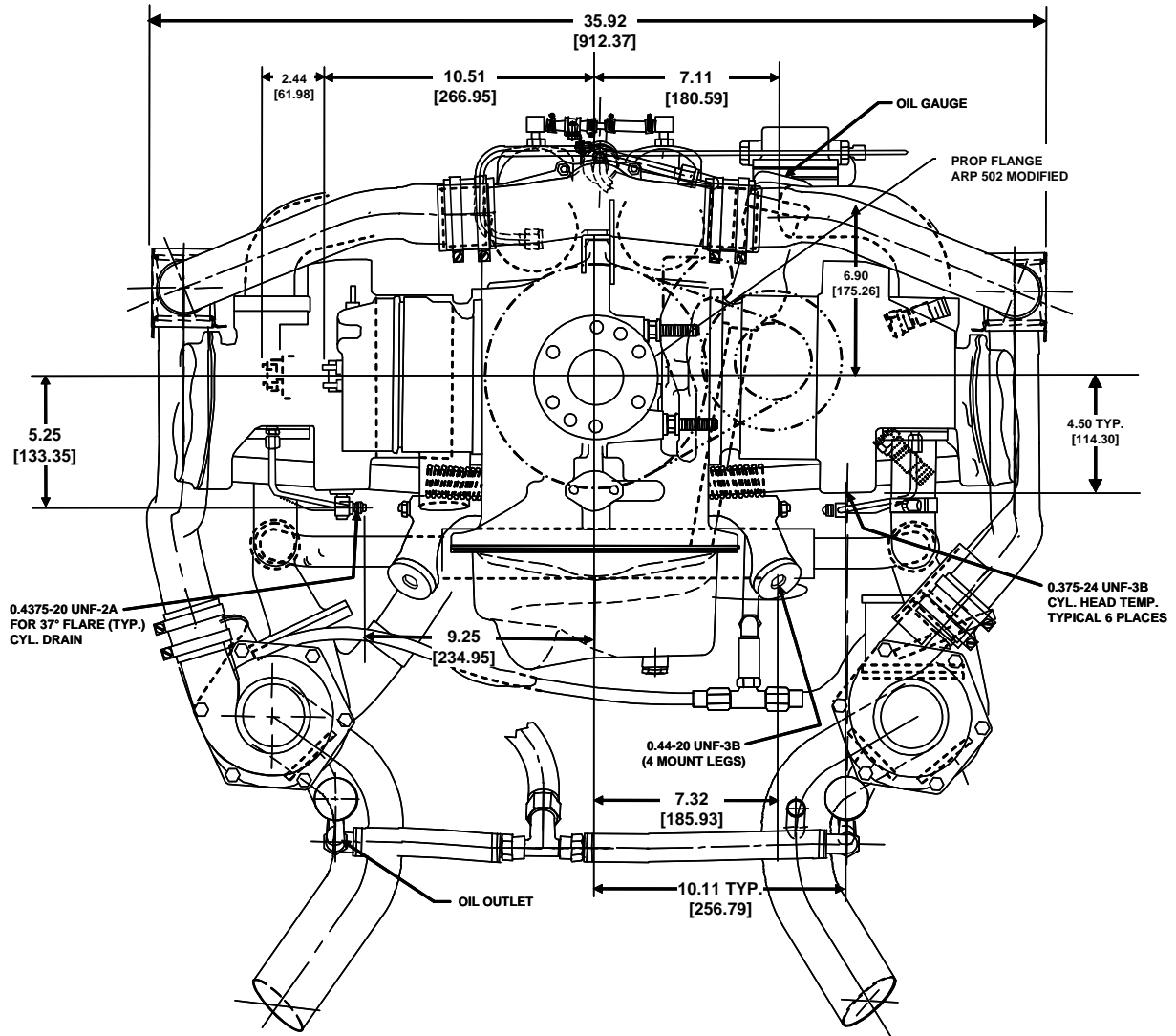

Figure 4-16. TSIO-550-G Front View

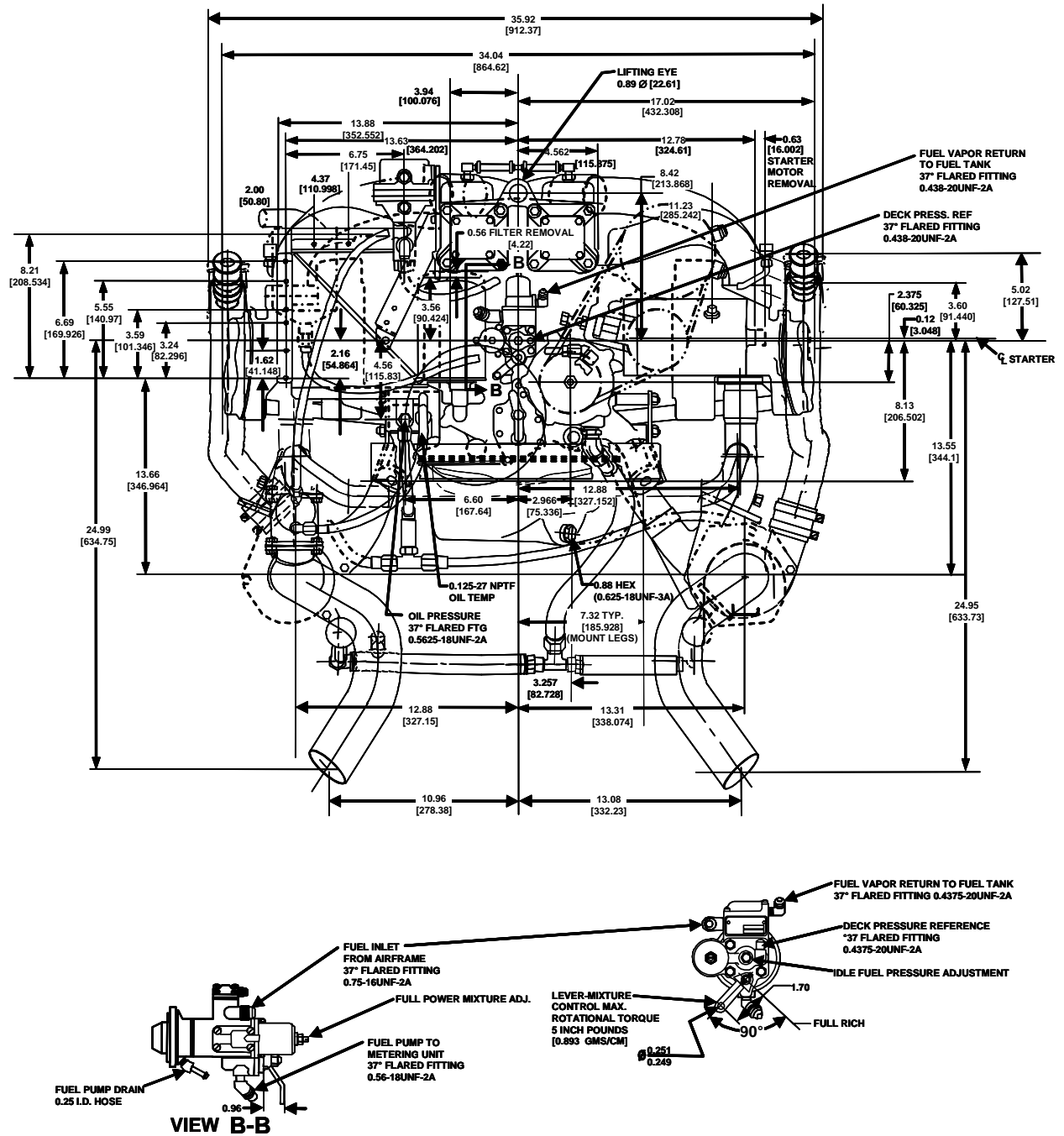

Figure 4-17. TSIO-550-G Rear View

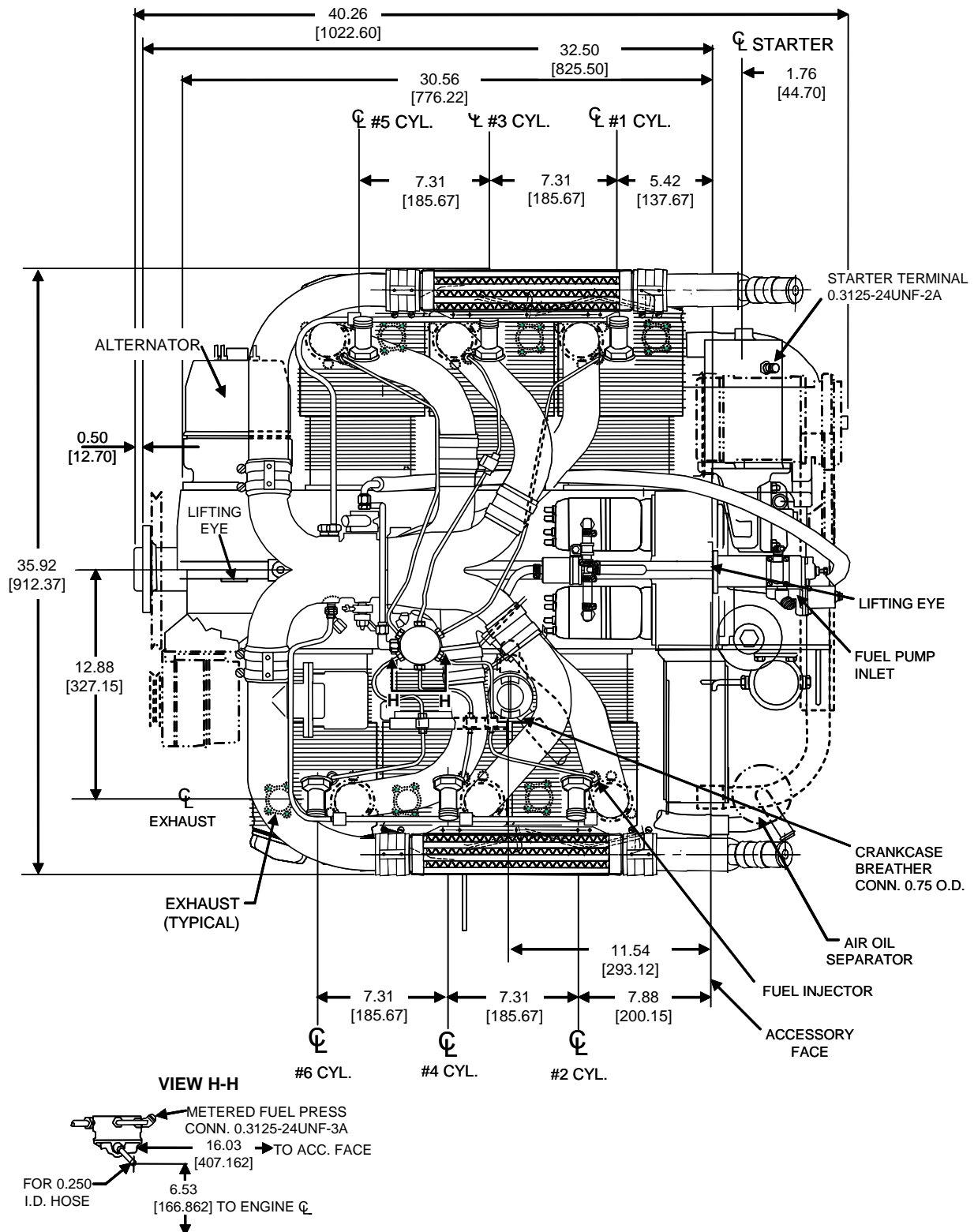

Figure 4-18. TSIO-550-G Top View

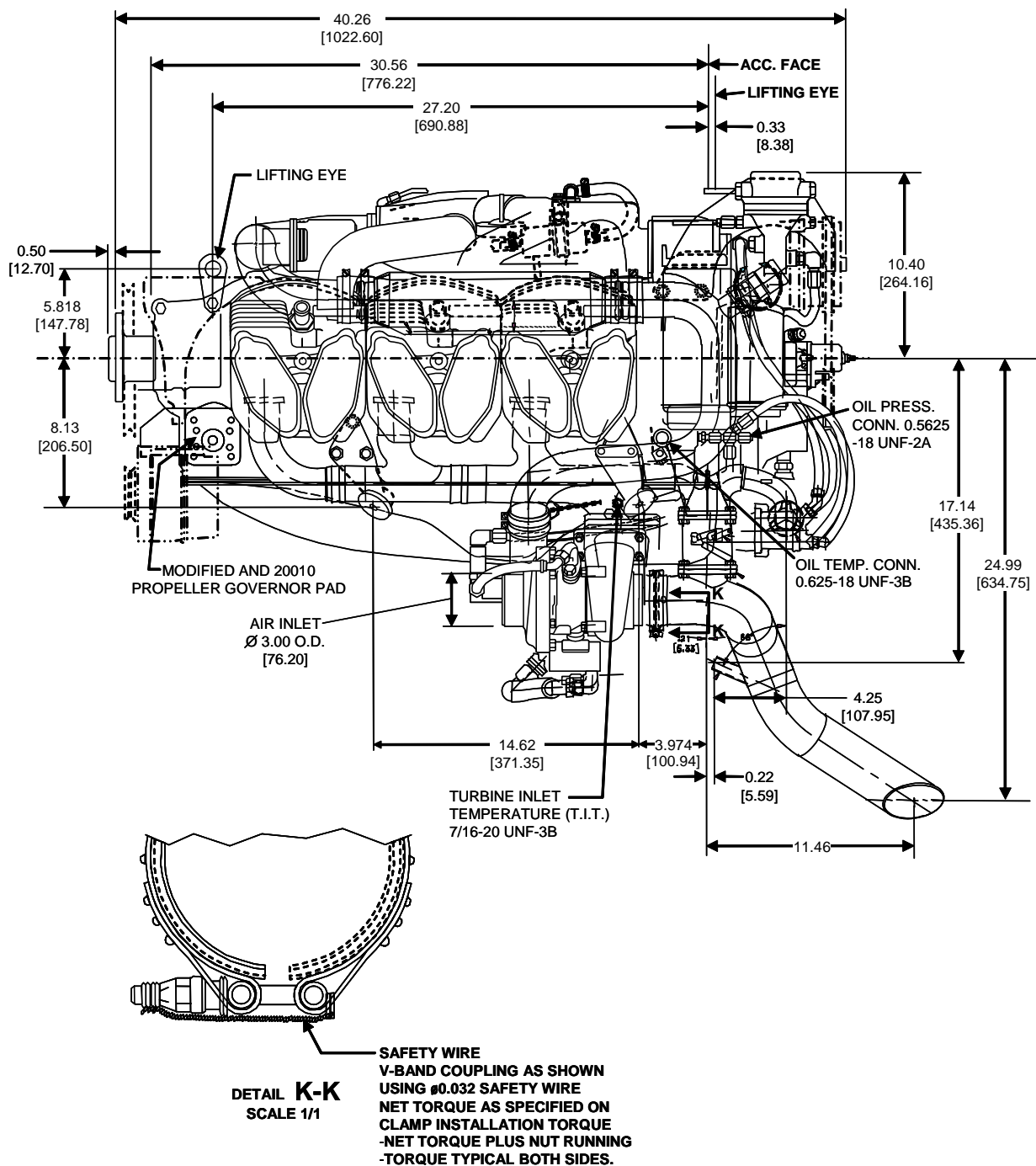

Figure 4-19. TSIO-550-G Left Side View

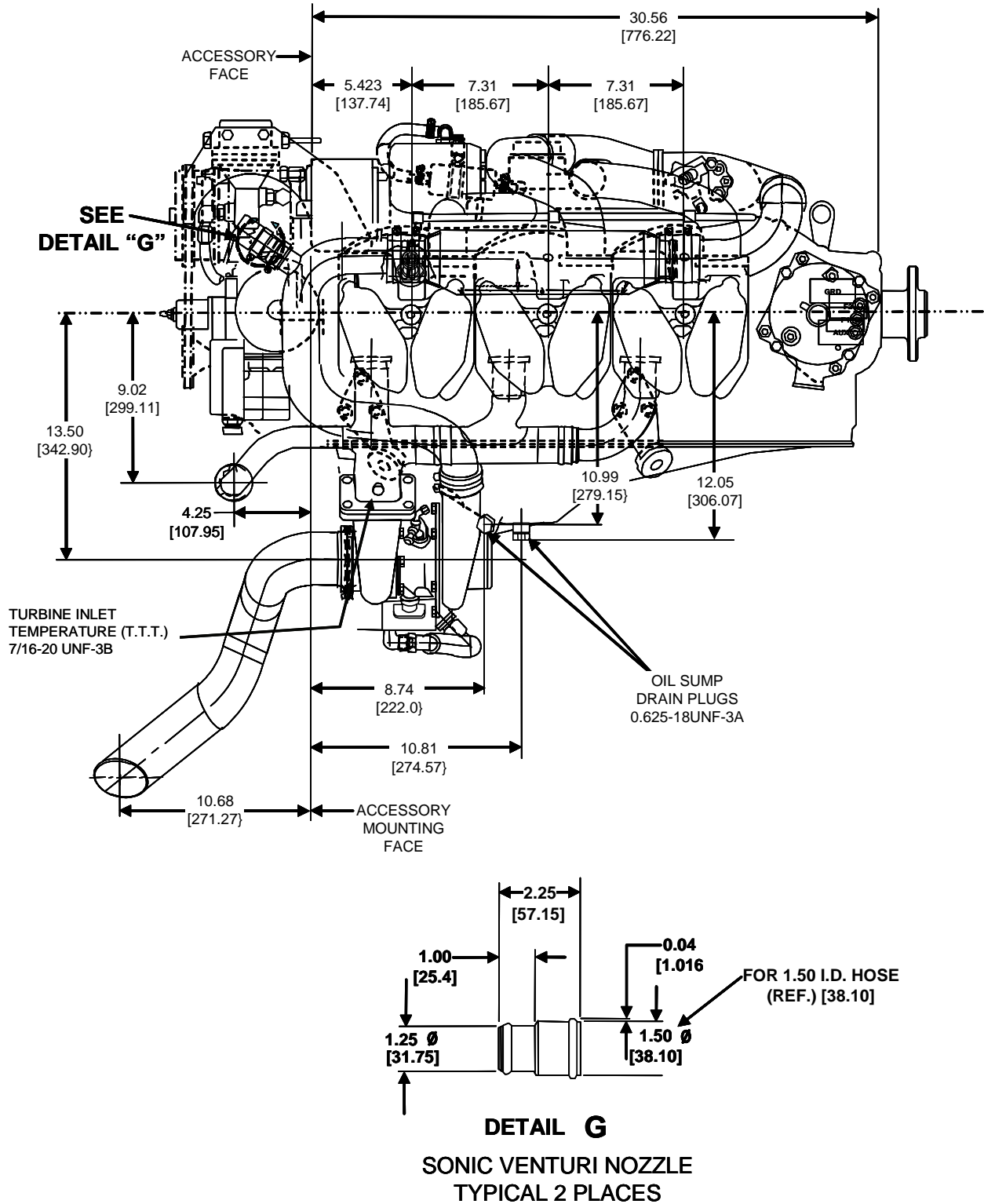

Figure 4-20. TSIO-550-G Right Side View

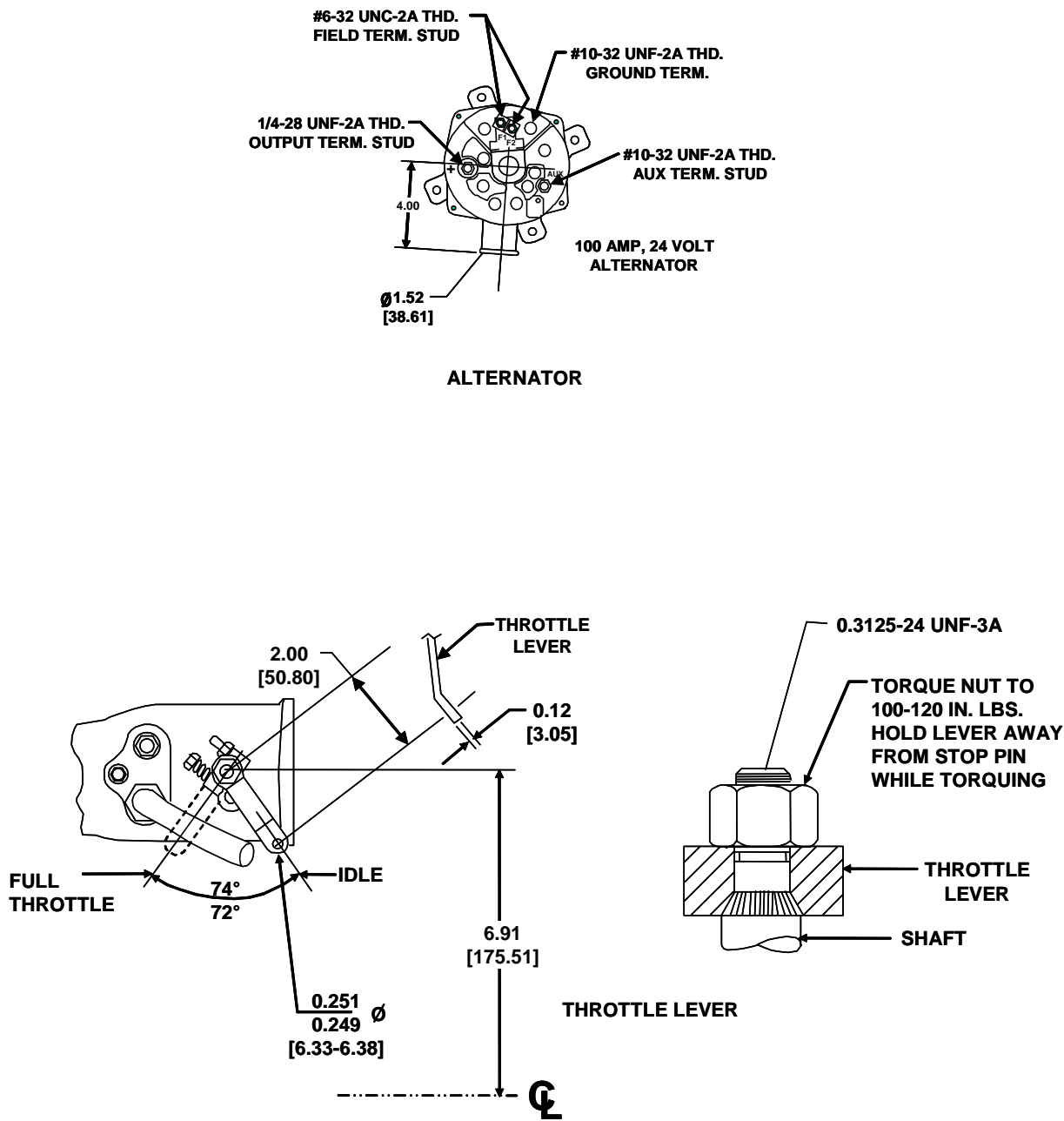

Figure 4-21. TSIO-550-G Alternator and Throttle Detail



Chapter 5. INSPECTION AND SERVICE
CONTENTS

Chapter 5. Inspection and Service..... 5-1
5-1. Scheduled Inspections and Service..... 5-3
5-1.1. Inspections and Service Intervals ..... 5-3
5-1.2. Scope of Inspections ..... 5-5
5-2. Inspection and Service Procedures ..... 5-7
5-2.1. Visual Inspections..... 5-7
5-2.2. Engine Oil Servicing ..... 5-8
5-2.3. Spark Plug Installation..... 5-13
5-2.4. Ignition Harness Installation..... 5-13
5-2.5. Magneto Timing ..... 5-15
5-2.6. Operational Checks..... 5-18
5-3. Unscheduled Maintenance..... 5-37
5-3.1. Propeller Strike ..... 5-37
5-3.2. Hydraulic Lock ..... 5-37
5-3.3. Engine Overspeed..... 5-38
5-3.4. Turbocharger Overboost..... 5-38
5-3.5. Lightning Strike..... 5-39
5-3.6. Contaminated Fuel System..... 5-39
5-3.7. Abnormal Ferrous Material in Oil Analysis ..... 5-39
5-3.8. Excessive or Abnormal Engine Noise ..... 5-39

LIST OF TABLES

Table 5-1. Maintenance Schedule..... 5-4
Table 5-2. Qualified Ashless Dispersant Lubricating Oils (SAE J 1899) ..... 5-9
Table 5-3. Engine Operation Prerequisites ..... 5-18
Table 5-4. TSIO-550 Engine Operating Limits ..... 5-19
Table 5-5. Static Ground Setup Compensation Table ..... 5-20
Table 5-1. Operational Checklist ..... 5-35



---

**LIST OF FIGURES**

Figure 5-1. TSIO-550 Oil Servicing Points ..... 5-11  
Figure 5-2. Ignition Lead Wire Lubrication ..... 5-14  
Figure 5-3. Ignition Lead Wire Connections on Magneto ..... 5-15  
Figure 5-4. Installed Timing Disk and TDC Locator ..... 5-16  
Figure 5-5. Number 1 cylinder positioned at top of intake stroke ..... 5-16  
Figure 5-6. Cylinder Number 1 Compression Stroke ..... 5-17  
Figure 5-7. Model 20 ATM-C Porta-Test ..... 5-25  
Figure 5-8. Porta-Test Connections ..... 5-25  
Figure 5-9. Fuel Injection System Gauge Hookup ..... 5-27  
Figure 5-10. Throttle Body Adjustments ..... 5-28  
Figure 5-11. Adjustment Screw on the Oil Pressure Relief Valve ..... 5-29  
Figure 5-12. Fuel Pump Adjustments ..... 5-30





This Chapter has three sections. The first section explains the frequency and scope of the inspections and maintenance required for TSIO-550 Permold series engines airworthiness. The second section contains limited service instructions and the last section describes events that trigger unscheduled inspections or maintenance.

## **5-1. Scheduled Inspections and Service**

The Inspection Program described in this chapter applies only to the Teledyne Continental Motors, Inc. (TCM) engines covered in this manual. The inspections must be performed on the engine as directed. Perform aircraft inspections as directed by the aircraft manufacturer. Periodic Inspections follow a schedule and may be accomplished using an Inspection Checklist. Refer to the detailed instructions in the TCM Maintenance and Overhaul Manual (M-18) for all the scheduled inspections identified in this section.

### **5-1.1. Inspections and Service Intervals**

Unless another FAA-approved Inspection Program is established, the Required Engine Inspection Schedule in Table 5-1 shows the inspections required by the manufacturer for engines covered in this manual. The time based inspections described in this chapter apply to the engine and not to the aircraft. Refer to the Airframe Manufacturer's manual for airframe inspection requirements. The inspections are progressive; commencing from the date the engine is placed in service. The inspection intervals are tracked by Engine Log entries and designated by hours of operation or calendar time, whichever occurs first.

#### **WARNING**

**Before performing any inspection or maintenance, ensure the Ignition Switch is turned OFF and disconnect engine power. Even with the Ignition Switch OFF, a loose or broken wire (if the power is not off) could enable the engine to start and the propeller to rotate. Never stand or place equipment within the arc of the propeller.**

NOTE: Correct any discrepancies discovered during inspections prior to releasing the engine for flight.



| Table 5-1. Maintenance Schedule  |  |
|--|--|
| Maintenance Item   | Interval   |
| <b>Time Based Inspections</b>  |  |
| Belt Tension Inspection (Optional Air Conditioner Compressor and belt-driven alternator)   | 5 hours after belt installation or adjustment  |
| 25-hour Initial Operation Inspection   | After operating a new or rebuilt/overhauled engine for the first 25 hours of initial service (engine-break-in)<br>If oil consumption has not stabilized, repeat this inspection after the next 25 hours of operation |
| 50-hour Engine Inspection  | 25 hours after the 25-hour Initial Operation Inspection<br>Then, after every 50 hours of operation   |
| 100-hour (Annual) Engine Inspection  | After every 100 hours of operation since placing the engine into service OR annually (whichever comes first)   |
| 500-hour Engine Inspection   | After every 500 hours of operation since placing the engine into service   |
| <b>Required Maintenance on Engines in Storage</b><br>(Refer to Chapter 6 for engine preservation and storage instructions.)  |  |
| Temporary Storage  | Engine not operated for 30 – 90 days   |
| Indefinite Storage   | Engine not operated for 90 days or more  |
| <b>Recommended Engine Oil Change Intervals</b>   |  |
| Scheduled:   |  |
| <ul style="list-style-type: none"> <li>• With integral oil screen</li> <li>• With full flow oil filter</li> </ul>  | <ul style="list-style-type: none"> <li>• 25 hours</li> <li>• 50 hours</li> </ul>   |
| Unscheduled: <ul style="list-style-type: none"> <li>• Prior to temporary storage</li> <li>• Prior to indefinite engine</li> <li>• Placing an engine in service after storage</li> <li>• Preparing a new or rebuilt engine for installation</li> <li>• Returning an overhauled or stored engine to service</li> <li>• After top overhaul of one or more engine cylinders</li> </ul> | <ul style="list-style-type: none"> <li>• 25 hours after engine is placed in service</li> </ul>   |
| <b>Recommended Engine Oil Filter or Screen Service</b>   |  |
| <ul style="list-style-type: none"> <li>• Integral oil screen</li> </ul>  | <ul style="list-style-type: none"> <li>• Inspect, clean and reinstall every 25 hours</li> </ul>  |
| <ul style="list-style-type: none"> <li>• Large (5.80 in) or small full flow filter</li> </ul>  | <ul style="list-style-type: none"> <li>• 50 hours (during oil change)</li> </ul>   |
| <b>Time Between Overhaul Intervals (TBO)</b>   |  |
| <ul style="list-style-type: none"> <li>• TSIO-550-B and -E models</li> </ul>   | <ul style="list-style-type: none"> <li>• 1600 hours or 12 years (whichever occurs first)</li> </ul>  |
| <ul style="list-style-type: none"> <li>• TSIO-550-C and -G models</li> </ul>   | <ul style="list-style-type: none"> <li>• 2000 hours or 12 years (whichever occurs first)</li> </ul>  |



## **5-1.2. Scope of Inspections**

### **5-1.2.1. Belt Tension Inspection**

If the engine is configured with an optional air conditioner and/or belt driven alternator and the drive belt is adjusted, the belt tension must be checked again after five hours of operation. Refer to Chapter 9 in the Maintenance and Overhaul Manual (M-18) for belt tension check and adjustment procedures.

### **5-1.2.2. 25-Hour Initial Operation Inspection**

A 25-hour Initial Operation Inspection is required under any of the following circumstances:

- After operating a new, repaired, or rebuilt/overhauled engine for the first 25 hours of initial service (engine-break-in) or 6 months after the engine was placed in service (whichever comes first).
- If one or more new engine cylinders and/or pistons or piston rings have been installed.
- After every 25 hours of operation until oil consumption has stabilized.

Inspection Items:

- Engine Operational Check
- Oil Change
- Visual Inspection
- 50 hour Inspection
- Oil Consumption Test
- System Drain Inspection
- Engine Operational Check

### **5-1.2.3. 50-Hour Engine Inspection**

The 50-hour Inspection circumstances:

- 25 hours after the 25-hour Initial Operation Inspection
- After every 50 hours of operation

Inspection Items:

- Engine Operational Check
- Oil Change
- Visual Inspection
- Induction Air Filter
- Oil Analysis
- Magneto Drop Check
- System Drain
- Engine Operational Check

#### **5-1.2.4. 100-Hour or Annual Engine Inspection**

An annual or 100-hour inspection is required, depending on utilization. Perform the inspection at whichever interval occurs first but do not exceed either interval.

The fuel injector nozzles must be cleaned at the first 100-hour inspection after installation of a new, rebuilt or overhauled engine. Thereafter, clean nozzles every 300 hours or annually.

Inspection Items:

- All 50-Hour Inspection Items plus
- Crankcase
- Cylinders, including
  - Cylinder-to-Crankcase Mounting Deck
  - Cylinder Differential Pressure Test
  - Borescope
  - Cylinder Power Stroke Area
- Flexible vibration dampeners
- Baffles
- Engine Controls
- Fuel Injection System
- Turbocharger and Exhaust System
- Ignition System
- Engine Gauges
- EGT/TIT accuracy
- Fuel and Throttle Control
- Engine Mounts
- Accessory wear
- Cowlings

#### **5-1.2.5. 500-Hour Engine Inspection**

After every 500 hours of elapsed operation, perform the following:

Inspection Items:

- All 100 Hour Inspection Items plus
- Alternator
- Magneto
- Induction Air Filter Replacement
- Engine Mounted Accessories
- Engine Controls



## **5-2. Inspection and Service Procedures**

### **5-2.1. Visual Inspections**

Begin any engine service or operation interval with a visual inspection using the following instructions:

1. Check that the nacelle is clean and free of fuel, oil leaks, dirt, and debris.
2. Inspect all fuel and lubrication lines for signs of chafing.
3. Inspect the aftercooler, oil cooler, and oil filter.
4. Check the following on the engine for cracks, dents, pitting and damage:
  - a. External cylinder barrel
  - b. Cylinder barrel fins
  - c. Areas between and adjacent to the cylinder barrel fins
  - d. External surface of the cylinder head, including areas around:
    - 1) Cylinder head fins
    - 2) Top and bottom spark plug bosses
    - 3) Fuel nozzle boss
    - 4) Crankcase external surfaces
    - 5) Accessories
    - 6) Support structure adjacent to accessories

NOTE: If the engine cylinder does not meet visual inspection criteria, perform a “Cylinder Inspection” according to the instructions in the Maintenance and Overhaul Manual (M-18).

5. Check the security of engine wiring harnesses, including the spark plug leads. Inspect ignition leads for chafing, deterioration and proper routing.
6. Replace any stressed or broken wire ties.
7. Check magnetos for external damage, cracks and security in mount. Ensure the cable outlet plate is securely fastened to the magneto and the ignition wires are properly connected.
8. Inspect external drive belts for nicks, cracks and visible wear; replace belts with nicks, cracks, or visible wear. Check the belt tension and adjust, as required (See Chapter 9 of the Maintenance and Overhaul Manual (M-18)).



9. Check electrical connectors for signs of corrosion or contamination. If corrosion or contamination is discovered on connectors, disconnect the connectors and inspect internal connector pins for corrosion or contamination.

NOTE: Inspect items 3-13 for obvious signs of physical damage, wear or deterioration, loose or missing hardware, leaks or foreign material (liquid or solid) that may hinder normal operation. Note and correct any discrepancies.

10. Inspect the Fuel Injection System integrity.
11. Inspect the Induction System integrity:
  - a. air box
  - b. ducts
  - c. seals
  - d. gaskets
12. Inspect the Lubrication System integrity.
13. Inspect the Turbocharger and Exhaust System integrity.
14. Repair any observable damage or discrepancy before the aircraft is returned to service.

### 5-2.2. Engine Oil Servicing

During normal operation, the engine lubrication system provides either pressure or splash oil to areas of the engine subject to frictional loading. A certain amount of oil consumption is normal if the plane is flown on a regular basis. However, if excessive oil consumption is noted (i.e. more than 1/2 quart (1/2 liter) per 1 hour of operation) or there is an abrupt change in the rate of oil consumption, determine the cause and correct it before further flight.

#### **WARNING**

**Do not fly the aircraft if oil consumption is abnormal or is suspect; investigate for oil leakage. If no oil leakage is noted, perform a “Cylinder Inspection” in Chapter 7, of the Maintenance and Overhaul Manual (M-18).**

Lubricating oils qualified for use in Teledyne Continental Motors engines are required to meet SAE (Society of Automotive Engineers) specifications:

SAE specification J 1899 (formerly MIL-L-22851D) is the approval for aircraft piston engine ashless-dispersant oil.

SAE specification J 1966 (formerly MIL-L-6082E) is the approval for aircraft piston engine non-dispersant mineral oil.

NOTE: MIL-L-6082E dated 1 November 1995 and MIL-L-22851D dated 1 November 1995 is hereby cancelled. Refer to SAE specification SAE J 1966 and SAE J 1899.



Teledyne Continental Motors listing of accepted SAE J 1899 oils by manufacturer and brand name is for the convenience of our customers. Always refer to the oil container label to verify the oil meets the appropriate SAE specification.

QPL-J 1899: Qualified Products List is available from:

SAE Headquarters  
400 Commonwealth Drive  
Warrendale, PA 15096-001

The Naval Air Systems Command is required to maintain QPL-J-1899 and QPL-J-1966.

Naval Air Systems Command  
Air 4.4.5  
Jefferson Davis Highway  
Arlington, VA. 22243-5120

When listing vendor product names, TCM makes no affirmation of the vendors' statements or claims. Listings are arranged alphabetically and provided solely for customer convenience. If the aviation oil you use or wish to use is not listed, contact the Naval Air Systems Command.

| Table 5-2. Qualified Ashless Dispersant Lubricating Oils (SAE J 1899) |   |
|---|---|
| SUPPLIER  | BRAND   |
| BP Oil Corporation  | BP Aero Oil   |
| Castrol   | Castrol Aero AD Oil                                       |
| Castrol Limited (Australia)   | Castrol Aero AD Oil                                       |
| Chevron USA   | Chevron Aero Oil  |
| Continental Oil   | Conoco Aero S   |
| Delta Petroleum Company   | Delta Avoil Oil   |
| Exxon Company, USA  | Exxon Elite   |
| Exxon Company, USA  | Exxon Aviation Oil EE                                     |
| Gulf Oil Company  | Gulfpride Aviation AD                                     |
| Mobil Oil Company   | Mobile Aero Oil   |
| NYCO SA   | Turbonycoil 3570  |
| Pennzoil Company  | Pennzoil Aircraft Engine Oil                              |
| Phillips Petroleum Company  | Phillips 66 Aviation Oil,<br>Type A 100 AD, 120 AD        |
| Phillips Petroleum Company  | X/C Aviation Multiviscosity Oil<br>SAE 20W-50, SAE 25W-60 |
| Quaker State Oil & Refining Co.                                       | Quaker State AD Aviation Oil                              |
| Red Ram Limited (Canada)  | Red Ram X/C Aviation Oil 20W-50                           |
| Shell - Australia   | Aeroshell (R) W   |
| Shell Canada Limited  | Aeroshell Oil W, 15W – 50 Anti-wear Formulation           |
| Shell USA   | Aeroshell Oil W, 15W – 50 Anti-wear Formulation           |
| Shell USA   | Aeroshell Oil W100 Plus, W80 Plus                         |
| Sinclair Oil Company  | Sinclair Avoil  |
| Texaco Inc.   | Texaco Aircraft Engine Oil-Premium AD                     |
| Total France  | Total Aero DM 15W - 50                                    |
| Union Oil Company of California                                       | Union Aircraft Engine Oil HD                              |

### 5-2.2.2. Check and Replenish Engine Oil

#### WARNING

**Check the oil level prior to flight; maintain the engine oil at the specified level. Operating an engine with no oil or below the designed capacity will cause engine malfunction or failure.**

1. Withdraw the oil gauge rod (dipstick).
2. Wipe the rod clean with a clean, lint-free cloth.
3. Insert the oil gauge rod into the oil sump and withdraw the rod again.
4. Verify the oil level touches but does not pass the fill line on the rod. If more oil is required, add a sufficient quantity of approved aviation engine oil to reach the oil gauge fill line.

NOTE: Oil sump capacities differ for the various TSIO-550 Series engines.

| Oil Type                                | When to Use  |
|---|--|
| SAEJ1966<br>(Nondispersant mineral oil) | Engine break-in<br>After installing a new, rebuilt, or overhauled engine for initial 25 hour operation |
| SAEJ1899<br>(Ashless dispersant oil)    | Routine oil change after engine break-in   |

#### WARNING

**Petroleum based aviation engine oil is flammable. Follow all fire hazard precautions. Store the oil in a well-ventilated area away from any heat or ignition source.**

**When adding oil, completely remove the protective seal on the oil container to prevent the seal from falling into the oil fill port. Prevent any debris from falling into the oil fill port.**

**If any oil is spilled on the engine and nacelle during filling, clean up the oil spills on the engine and nacelle. Follow precautions in wiping up oil spills.**

### 5-2.2.3. Oil Change

*CAUTION: Dispose of oil waste in accordance with environmental standards.*

Perform an oil change within 30 minutes of engine shutdown (to obtain a useful oil sample). Oil changes are recommended at the intervals in Table 5-1, in section 5-1.1, "Inspection and Service Intervals," earlier in this section.





NOTE: TCM recommends more frequent oil changes for extreme weather conditions.

1. Remove the oil sump drain plug (Figure 5-1) and drain the oil into a safety-approved catch basin. After approximately 1/3 of the oil drains from the sump, use clean tubes, funnels, and a sample (30 to 60 ml) vial to collect 1-2 ounces of the used oil. If a magnetic drain plug is used, check for signs of ferrous material (e.g., steel, iron).

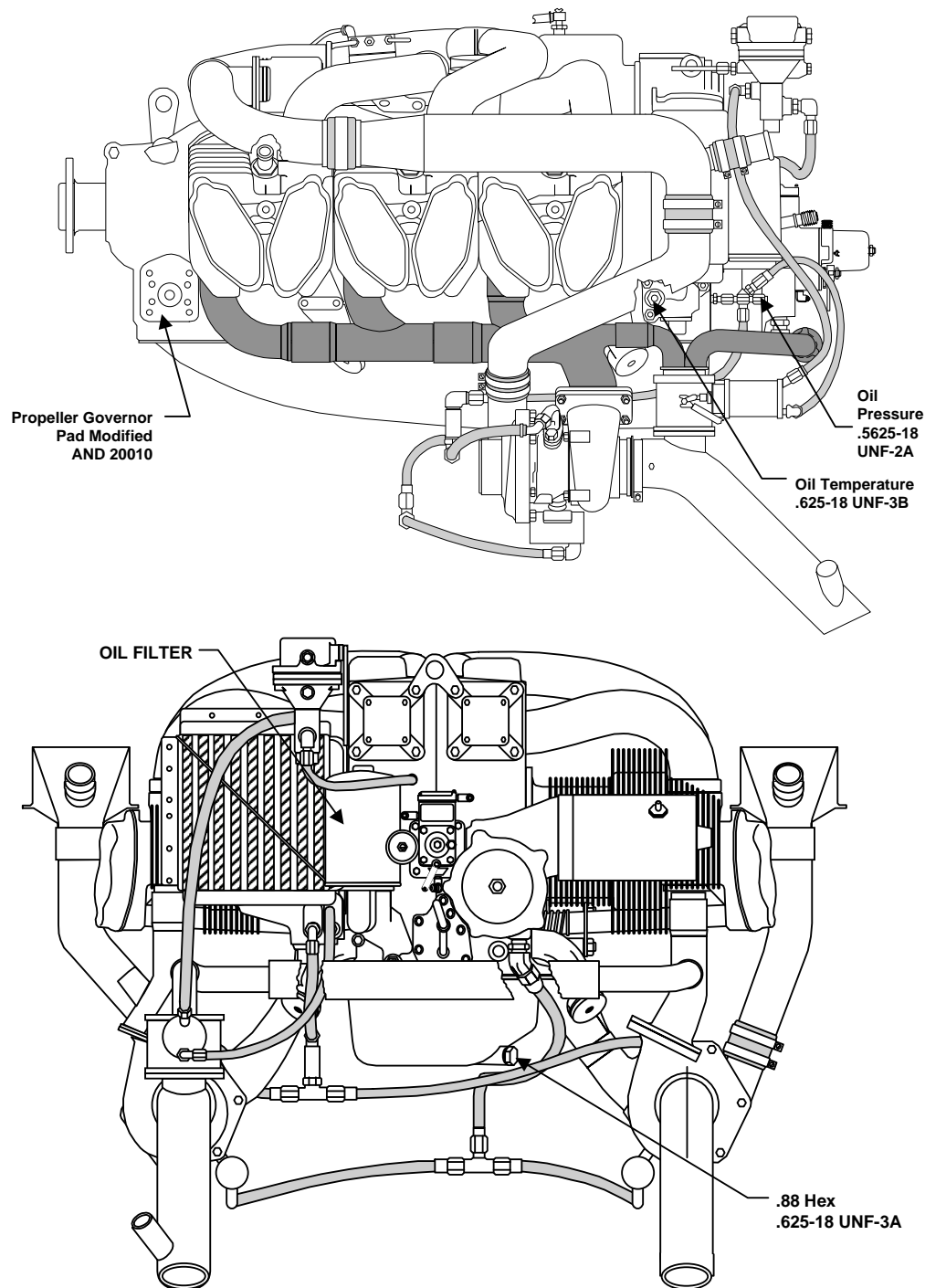

**Figure 5-1. TSIO-550 Oil Servicing Points**



NOTE: TCM recommends customers submit a sample of the drained oil from the first, second, and third oil changes on new, rebuilt, or overhauled engines for spectrographic oil analysis to establish a wear trend baseline. TCM also recommends continued oil sample analysis during each 50-hour Engine Maintenance Inspection, or if engine trouble is suspected.

2. Reinstall the drain plug with a new crush gasket; torque per Appendix B. Safety wire the plug according to Appendix C instructions.
3. Remove the oil filter (Figure 5-1). Cut the oil filter open with the Oil Filter Can Cutter (CT-470). Inspect the oil filter for metal debris trapped within the filter to assess the engine condition. Use a magnet to check for steel particulate. New, rebuilt, or overhauled engines typically exhibit more wear material on the first and second oil filter change, which is normal. Wear material quantity should lessen during subsequent oil changes. If the same quantity of wear material is noted on subsequent oil changes, determine the characteristics of the wear material (see “Spectrographic Oil Analysis” in the Maintenance and Overhaul Manual (M-18)) and troubleshoot the engine as directed in Chapter 8 of the Maintenance and Overhaul Manual (M-18).
4. Apply a thin coating of Dow Corning DC-4 compound to the filter gasket mating surface. Install the new oil filter; torque the filter per Appendix B and safety wire it per Appendix C.
5. Add new oil and check the oil level (see “Check and Replenish Engine Oil”).
6. Check for oil leaks (see “Check for Oil Leaks.”)

#### 5-2.2.4. Check for Oil Leaks

### WARNING

**Keep the engine compartment, nacelle, and fuselage adjacent to the nacelle clean to enable detection of any oil leaks before preparing for flight.**

1. Check the engine nacelle, engine compartment, and adjacent area for oil leaks.
2. If leaks are found, determine the source and correct the cause of the leak(s).
3. Check the oil level and add oil as described in the section “Check and Replenish Engine Oil” in this chapter to the specified capacity for the engine model.
4. Check the oil level after adding oil to verify the sump is filled to the proper level. For oil sump capacity, refer to “Engine Specifications and Operating Limits” in Chapter 2, Engine Description, of this manual. Note oil sump capacities vary between TSIO-550 Series engine models.



### 5-2.3. Spark Plug Installation

1. Set the spark plug gap using manufacturer's data for the appropriate part number.
2. Install a new copper gasket on all 12 spark plugs.

*CAUTION: Failure to install a new spark plug gasket any time a spark plug is installed may result in incomplete sealing of the combustion chamber, loss of spark plug heat transfer, spark plug overheating, possible re-ignition/detonation, and internal engine damage.*

3. Sparingly apply Champion spark plug lubricant to all except the first spark plug threads.
4. Thread the spark plug by hand into the engine cylinder head within one to two threads of the gasket. If the spark plug does not turn smoothly, clean the cylinder or spark plug threads.
5. Torque the spark plug according to Appendix B specifications using a currently calibrated torque wrench and six-point deep well socket.

### 5-2.4. Ignition Harness Installation

#### **WARNING**

**Do not connect the high voltage harness to the spark plugs until propeller installation is complete. Failure to comply can result in bodily injury when the propeller is rotated during installation.**

NOTE: The high tension cable outlet plates are keyed to attach to either magneto in only one position. The number 1 position is marked on the magneto cover and aligns with the firing position for cylinder number 1.

1. Inspect the spark plug leads for chafing, heat damage, wear, and cracking. Replace damaged cables. Inspect the cable outlet plate for cracks.
2. Clean and spray the magneto and cable outlet plate mating surfaces with MS 122/DF spray before installing the harness on the magneto.
3. Install the ignition harness and cable outlet plate on the magneto; tighten the cable outlet plate screws alternately to seat the cable outlet plate properly on magneto. Torque the screws according to Appendix B.
4. Install the ignition harness, observing the following precautions:
  - a. Support leads with the necessary clamps and cable ties to prevent whipping or chafing action.
  - b. Route leads as far away as possible from the exhaust manifold to ensure they are not exposed to temperatures in excess of 400°F.



- c. To prevent sticking of sleeves and to minimize twisting of ferrule, coat insulating sleeves (see Figure 5-2) with MS 122/DF spray.
- d. Apply a light coat of Shell Alvania No. 2 lubricant to the contact point between the nut seat and ferrule on each ignition lead.
- e. Leads are labeled with cylinder numbers. Route the high tension leads to the spark plug matching the number on the harness lead.

*CAUTION: The maximum allowable distance between unsupported wiring harness segments is eight (8) inches. Install clamps to secure wiring harnesses and provide strain relief.*

5. Clamp the harness leads, as required, in the clamps provided.
6. Wipe the spark plug lead connector clean using a lint-free cloth moistened with MEK, acetone, wood alcohol, or naphtha.
7. Verify the inside of the spark plug barrel is clean and dry.

*CAUTION: Hold ferrules while torquing or loosening spark plug coupling nuts to protect against twisting conduit or cable.*

8. Insert the spring-end of the lead into the spark plug barrel. While holding the lead wire B-nut, firmly push the rubber insulator into the spark plug.

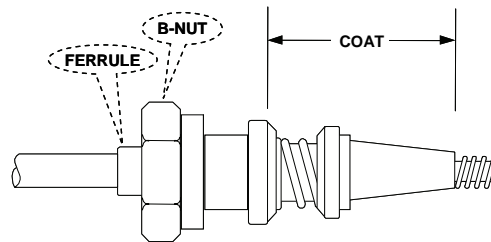

**Figure 5-2. Ignition Lead Wire Lubrication**

9. Push the ferrule against the spark plug and begin turning the B-nut clockwise. Continue rotating the B-nut until it seats and is finger-tight. While holding the spark plug lead ferrule stationary, tighten the B-nut an additional 1/8 turn with the correct size open end wrench. Torque the B-nut per Appendix B in this manual.

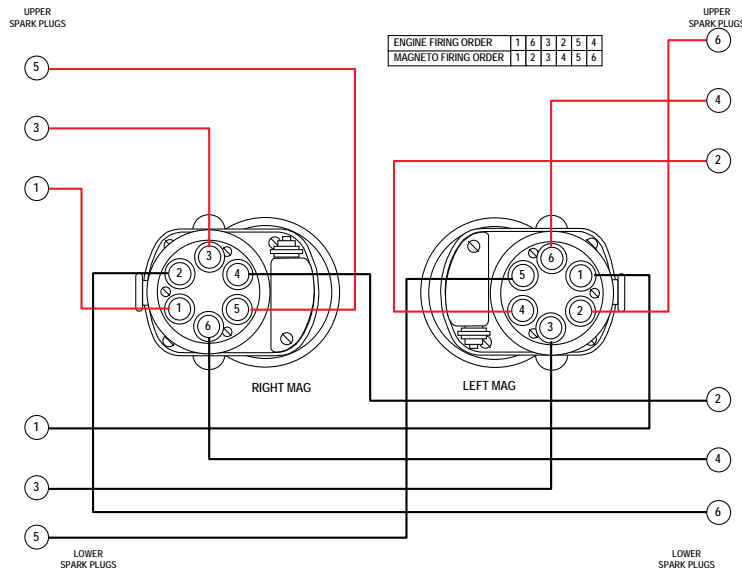

Figure 5-3. Ignition Lead Wire Connections on Magneto

### 5-2.5. Magneto Timing

#### Equipment Required

- Eastern Electronics Model E25 Timing Indicator (or equivalent)
- Top Dead Center Locator
- Eastern Electronics Model E50 timing light (or equivalent)

NOTE: Refer to the engine timing specification in Chapter 2, Engine Description.

#### 5-2.5.1. Crankshaft Top Dead Center Alignment

#### WARNING

Place the ignition switch in the OFF position; disconnect the aircraft battery; disconnect the ignition leads from the spark plugs. Attach a “Hot Magneto-Do Not Turn” sign to the propeller.

*CAUTION: The importance of establishing and maintaining correct magneto timing cannot be overemphasized. Incorrect timing, in addition to a rough running engine, can lead to detonation, pre-ignition and possible internal engine damage or failure.*

NOTE: Some starter drive adapters incorporate an over-riding spring clutch design that restricts engine rotation in the opposite direction of normal rotation. If the engine does not freely turn in the opposite direction of normal rotation, the starter motor must be removed in order to complete magneto to engine timing.

1. Remove top spark plugs from the engine. Rotate the crankshaft to the start of the compression stroke on the number 1 cylinder. Install the top dead center (TDC) locator (see Figure 5-4) in the number one cylinder spark plug hole.
2. Install the timing disk indicator on the crankshaft flange, propeller spinner or propeller hub.
3. Turn propeller slowly in the direction of normal rotation until the piston lightly touches the top dead center locator.
4. Rotate the timing disc until the 0° mark aligns with the pointer.

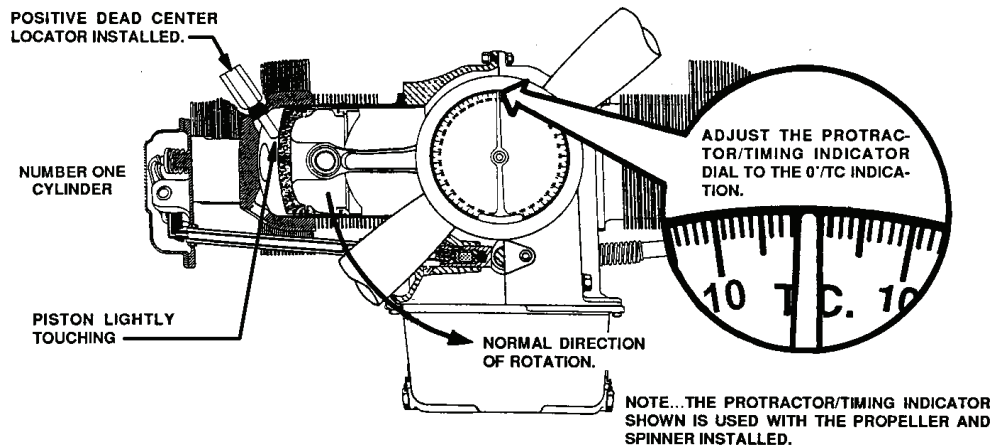

**Figure 5-4. Installed Timing Disk and TDC Locator**

5. Slowly rotate the crankshaft in the opposite direction of normal rotation (Figure 5-5) until the piston lightly touches the top dead center locator. Observe the marking on the disk under the pointer.

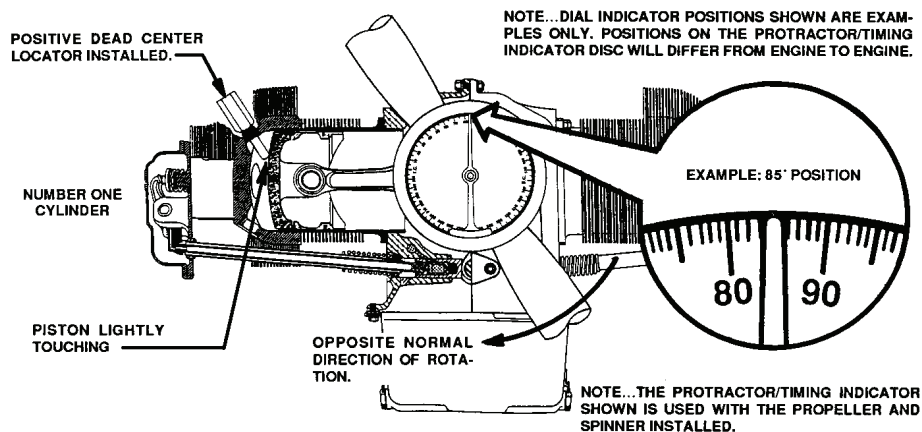
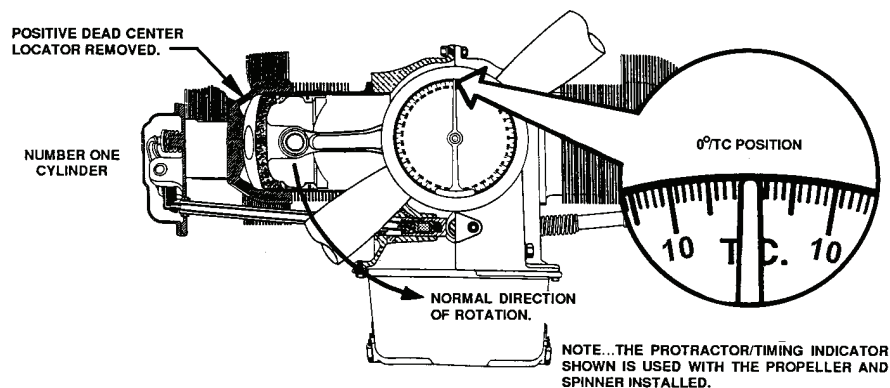

**Figure 5-5. Number 1 cylinder positioned at top of intake stroke**

6. Move the disk exactly one half of the number of degrees observed in step 5.
7. The crankshaft is now positioned at Top Dead Center (TDC) and prepared for magneto removal, installation or magneto to engine timing.

### 5-2.5.2. Magneto to Engine Timing

1. Complete the steps in section 5-2.5.1 “Crankshaft Top Dead Center Alignment.”
2. Remove the Top Dead Center locator from the number 1 cylinder (Figure 5-6). Find the number 1 cylinder compression stroke by placing a finger over the spark plug hole as the crankshaft is rotated. Continue rotating the crankshaft on the compression stroke until the 0° mark is aligned with the pointer. On magnetos equipped with impulse couplings, continue turning the crankshaft in the normal direction of rotation until each impulse coupling trips. Couplings may trip a few degrees on either side of TDC. If one or both couplings trip after TDC, turn the propeller back to a few degrees before TDC and approach the TDC position from the normal direction of rotation.



**Figure 5-6. Cylinder Number 1 Compression Stroke**

3. Turn the propeller counterclockwise past the specified magneto timing setting to remove gear backlash. Move the propeller in the direction of normal rotation until the pointer aligns with the desired timing setting.

NOTE: Be familiar with the test equipment operation prior to use. Some timing lights indicate proper ignition timing by illuminating a lamp; other models illuminate the lamp until the magneto cam lobe opens the circuit to turn the lamp off. Some timing indicators use an audible signal to indicate timing status.

4. Disconnect the ground switch leads from the magnetos. Connect a timing light right lead to the right magneto ground terminal and the left lead to the left magneto ground terminal. Connect the timing light ground lead to a suitable ground on the engine such as an unpainted bolt or stud.
5. With the crankshaft in the correct timing position, turn the propeller a few degrees counterclockwise before the point of ignition to clear valve backlash. Turn the propeller in the direction of rotation toward ignition and observe the timing light as the needle approaches the point of ignition. As the pointer aligns with the correct ignition timing, both lights should indicate proper timing.
6. If the timing lamp fails to illuminate, loosen the nuts securing the magneto to the mounting flange and attempt to rotate the magneto to the left or right in the mount until the lamp illuminates. If magneto timing adjustment is not possible, remove the suspect magneto and repair it in accordance with magneto manufacturer's service instructions.

### 5-2.6. Operational Checks

**WARNING**

**Flight is prohibited until the engine successfully completes the operational check and a flight check. If abnormal engine operation is observed or leaks occur, do not take-off. Determine the cause of the problem and take corrective action.**

Operational checks must be performed after any of the following:

- Engine Installation
- Maintenance or Troubleshooting
- Overhaul
- Return from storage
- During Scheduled Inspections

Perform the tasks listed in Table 5-3 on newly installed, repaired, or overhauled engines before releasing the engine for normal flight.

**WARNING**

**The tasks listed in Table 5-3 must be completed on newly installed, routinely inspected, repaired, or overhauled engines before the aircraft is released for normal service. DO NOT FLY THE AIRCRAFT UNTIL ALL OF FLIGHT PREREQUISITES HAVE BEEN MET.**

| Table 5-3. Engine Operation Prerequisites   |                                  |                                  |
|---|----------------------------------|----------------------------------|
| Sequence  | Requirement                      | Section References               |
| 1   | Prepare the Engine for Operation | Maintenance Preflight Inspection |
| 2   | Check Engine Operation           | Engine Operational Check         |
| 3   | Complete Operational Checklist   | Operational Checklist            |
| 5   | Complete Flight Check            | "Flight Check", Chapter 7        |
| *Also in accordance with the Airplane Flight Manual/Pilot's Operating Handbook (AFM/POH). |                                  |                                  |





Table 5-4. TSIO-550 Engine Operating Limits

| Specification   | Limit  |                             |                             |                             |
|---|--|-----------------------------|-----------------------------|-----------------------------|
|   | B  | C                           | E                           | G                           |
| Full Throttle Speed ±25 RPM   | 2700   | 2600                        | 2700                        | 2700                        |
| Idle Speed RPM ± 25 RPM   | 600  | 600                         | 600                         | 600                         |
| Rated Manifold Air Pressure (full throttle@ sea level) ± 0.2 in. Hg   | 38.0   | 35.5                        | 38.5                        | 34.0                        |
| Engine Intake Air Temperature   | Ambient  | Ambient                     | Ambient                     | Ambient                     |
| Engine Intake Air Pressure  | Ambient  | Ambient                     | Ambient                     | Ambient                     |
| Fuel Grade (Octane)   | 100-LL Blue or 100 Green   | 100-LL Blue or 100 Green    | 100-LL Blue or 100 Green    | 100-LL Blue or 100 Green    |
| Unmetered Fuel Pump Pressure (Idle) (psi)   | 7.0-9.0  | 7.0-9.0                     | 7.0-9.0                     | 7.0-9.0                     |
| Metered Nozzle Pressure (psi)   | 15.3-16.9  | 12.7-13.9                   | 15.3-16.9                   | 12.4-13.6                   |
| Unmetered Fuel Pump Pressure (Full Power) (Reference) (psi)   | 32-36  | 26-29                       | 32-36                       | 20.5-23.5                   |
| Full Throttle Fuel Flow (lbs/Hr)  | 245-255  | 212-224                     | 245-255                     | 200-210                     |
| Oil Temperature (Minimum)   | 100°F (38°)  | 100°F (38°)                 | 100°F (38°)                 | 100°F (38°)                 |
| Oil Temperature (Maximum)   | 240°F (116°C)  | 240°F (116°C)               | 240°F (116°C)               | 240°F (116°C)               |
| Oil Pressure (Cold) (Maximum)   | 100 psig   | 100 psig                    | 100 psig                    | 100 psig                    |
| Oil Pressure (Minimum)  | 10 psig  | 10 psig                     | 10 psig                     | 10 psig                     |
| Oil Sump Capacity (quarts)  | 12   | 8                           | 12                          | 8                           |
| Crankcase Pressure <sup>①</sup> (Max.)  | 4.0 Inches H <sub>2</sub> O  | 4.0 Inches H <sub>2</sub> O | 4.0 Inches H <sub>2</sub> O | 4.0 Inches H <sub>2</sub> O |
| Magneto Drop/Spread   | 150/50   | 150/50                      | 150/50                      | 150/50                      |
| Cylinder Head Temperature with Bayonet Thermocouple (Limit)   | 460°F Max. (238°C Max.)  | 460°F Max. (238°C Max.)     | 460°F Max. (238°C Max.)     | 460°F Max. (238°C Max.)     |
| Oil Consumption   | 0.006 x (rated power of engine) x (%power at which measured/100) x (hours duration) = amt. of oil consumed<br>1 quart of oil = 1.875 lbs<br>(Refer to the "Oil Consumption Test" in Chapter 18 in the Maintenance and Overhaul Manual(M-18)) |                             |                             |                             |
| ① A sudden increase in crankcase pressure during which the liquid in the manometer fluctuates rapidly typically indicates sticking piston rings. However, before removing cylinders, investigate the breather and manometer. Refer to "Excessive Crankcase Pressure" in Chapter 8, Troubleshooting in the Maintenance and Overhaul Manual (M-18) for details. |  |                             |                             |                             |





### **Required Test Equipment**

- Portable Tachometer
- Model 20 ATM-C Porta Test Unit  
OR
- Calibrated pressure gauges

NOTE: Pressure gauges must be accurate within +/- 1% and calibrated annually.

- A calibrated 0-60 psi gauge graduated in 1 psi increments (unmetered pressure).
- A calibrated differential pressure gauge, 0-30 psid maximum, graduated in .2 psi increments (metered differential pressure and fuel flow gauge verification).
- Two P/N MS51523-B4 swivel tees used to insert gauges inline with fuel lines for metered and unmetered pressure references.
- Hoses of sufficient length to allow personnel and equipment to perform the test at a safe distance from the propeller arc and blast area.

Setup instructions differ for the fuel system, depending on the test equipment being used. If a Porta-Test Unit will be used for the operational check, follow the instruction in section 5-2.6.1.1. If using calibrated gauges for the operational check, begin with section 5-2.6.1.2. When the test equipment is set up properly, proceed with the Operational Check Procedure in 5-2.6.2.

### 5-2.6.1. Maintenance Preflight Inspection

Prior to starting the engine, a complete preflight inspection of the engine, propeller, nacelle, and aircraft must be accomplished. Perform the inspection prior to the first flight following engine installation, inspection, troubleshooting, maintenance, or overhaul work to determine if the aircraft and engine are in an airworthy condition. Do not allow a malfunctioning engine to return to flight.

#### **WARNING**

**Operation of a malfunctioning engine can result in additional damage to the engine, possible bodily injury, or death.**

1. Turn the Master Power Switch, Fuel Control Valve, and the Magneto Switch to the OFF position.
2. Remove engine cowling in accordance with airframe manufacturer's instructions.
3. Check the throttle, propeller, and alternate air supply controls for freedom of movement and for full range of travel.

#### **WARNING**

**Ensure the propeller arc is clear of personnel and obstructions before starting the engine.**

4. Drain the aircraft fuel sumps according to the airframe manufacturer's instructions.
5. Remove, clean, inspect, and reinstall the aircraft fuel screens according to the airframe manufacturer's instructions.
6. Inspect the aircraft vapor return system for proper operation in accordance with airframe manufacturer's instructions.
7. Purge the aircraft fuel system.
  - a. Disconnect the fuel supply hose from the engine driven fuel pump and terminate the fuel supply hose in a large, clean container suitable for waste fuel.
  - b. Operate the aircraft fuel boost pump to allow a minimum of one gallon of fuel to flow into the container. Inspect the fuel for contaminants; locate and correct the source of contaminated fuel, if detected.
  - c. Reconnect the fuel supply line and torque according to Appendix B.

#### **WARNING**

**Use of inaccurate gauges will result in incorrect fuel system adjustment, probable accelerated engine wear and possible engine damage.**

8. Verify the fuel system components are properly configured (part numbers conform to type design and parts are installed properly).



9. Ensure the fuel manifold valve vent and fuel pump drain lines are properly installed, open and free of obstructions.
10. Inspect the engine control rod ends for wear, proper installation and security in accordance with airframe manufacturer's instructions.
11. Lubricate engine control rod ends and fuel system moving parts.

**WARNING**

**The engine is certified for operation with 100-LL Blue or 100 Green aviation fuel. If the minimum grade required is not available, use the next higher grade. If the aircraft is inadvertently serviced with the wrong grade of fuel, drain the fuel system completely and service the fuel tanks in accordance with the aircraft manufacturer's instructions. Perform a "Contaminated Fuel System Inspection" (see section 5-3.6).**

12. Service the aircraft fuel system according to the airframe manufacturer's instructions.
13. Check the engine oil level. Service the oil sump as required with the oil grade specified in "Engine Oil Servicing" in this section.
14. Verify the engine crankcase breather is secure with no breather air flow restrictions.
15. If the engine is newly installed or being returned to service after long-term storage, pre-oil the engine. Refer to "Engine Pre-oiling" in Chapter 4.
16. Verify the induction air filter is clean and securely in place. Replace the air filter with a clean one if it is dirty; tighten the filter if it is loose.
17. Visually inspect the engine, propeller hub area, and nacelle for evidence of fuel and engine oil leaks. Correct any discrepancies.
18. Visually inspect the engine and nacelle for debris, loose, missing or broken lines, hoses, fittings, clamps and connections. Inspect for restrictions to cooling airflow; remove any debris.
19. Verify all baffles and baffle seals are installed, correctly positioned, and serviceable.
20. If the engine has been exposed to temperatures below 20°F (-7°C) for more than 2 hours, preheat the engine according to "Engine Preheating Procedures" section in Chapter 7, "Engine Operation". If the engine has been exposed to an ambient temperature between 20 to 40°F (-7 to 4°C), refer to section "Cold Weather Starting without Preheating" in Chapter 7, "Engine Operation."

### 5-2.6.1.1. Porta-Test Unit Connections

1. Loosen the unmetered fuel supply hose from either the fuel pump outlet fitting or the fuel control inlet fitting, depending on access to connections.
2. Connect one MS51523-B4 swivel tee to the fuel connection loosened in step 1.

NOTE: Some installations may require a number of fittings to adapt the metered and unmetered test equipment to the fuel injection system.

3. Connect the unmetered fuel supply hose to the straight end of the tee connector.
4. Connect the Porta-Test Unmetered Pressure hose to the tee connector.
5. Remove the cap from the metered fuel port fitting on the fuel manifold valve.
6. Disconnect an upper deck pressure fitting at the throttle body or intake manifold. Install an MS51523-B4 swivel tee inline with the upper deck pressure fittings.
7. Connect the Porta Test Unit metered pressure test hose to the metered pressure fuel port on the fuel manifold valve fitting.
8. Connect the Porta Test Manifold Pressure and Upper Deck Pressure hose to the engine according the Porta Test instructions.
9. Torque all connections according to Appendix B specifications.
10. Position the throttle control to the FULL OPEN position and the mixture control to FULL RICH. Operate the aircraft boost pump in accordance with the aircraft manufacturer's instructions. Bleed the air from the test unit and hoses according to the Porta-Test unit instructions.

#### **WARNING**

**Drain all fuel from the induction system prior to attempting engine start. Failure to comply may result in hydraulic lock and subsequent engine failure.**

11. Install the engine cowling or cooling shroud during ground operation.
12. Proceed to Section 5-2.6.2.

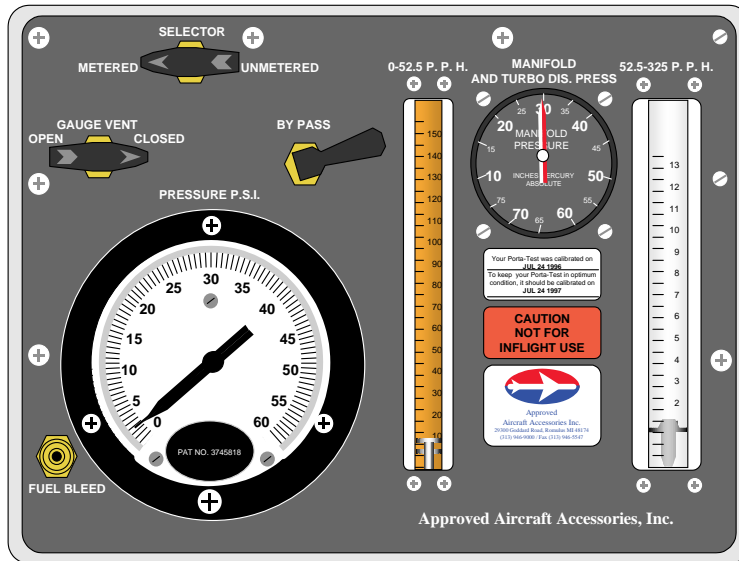

Figure 5-7. Model 20 ATM-C Porta-Test

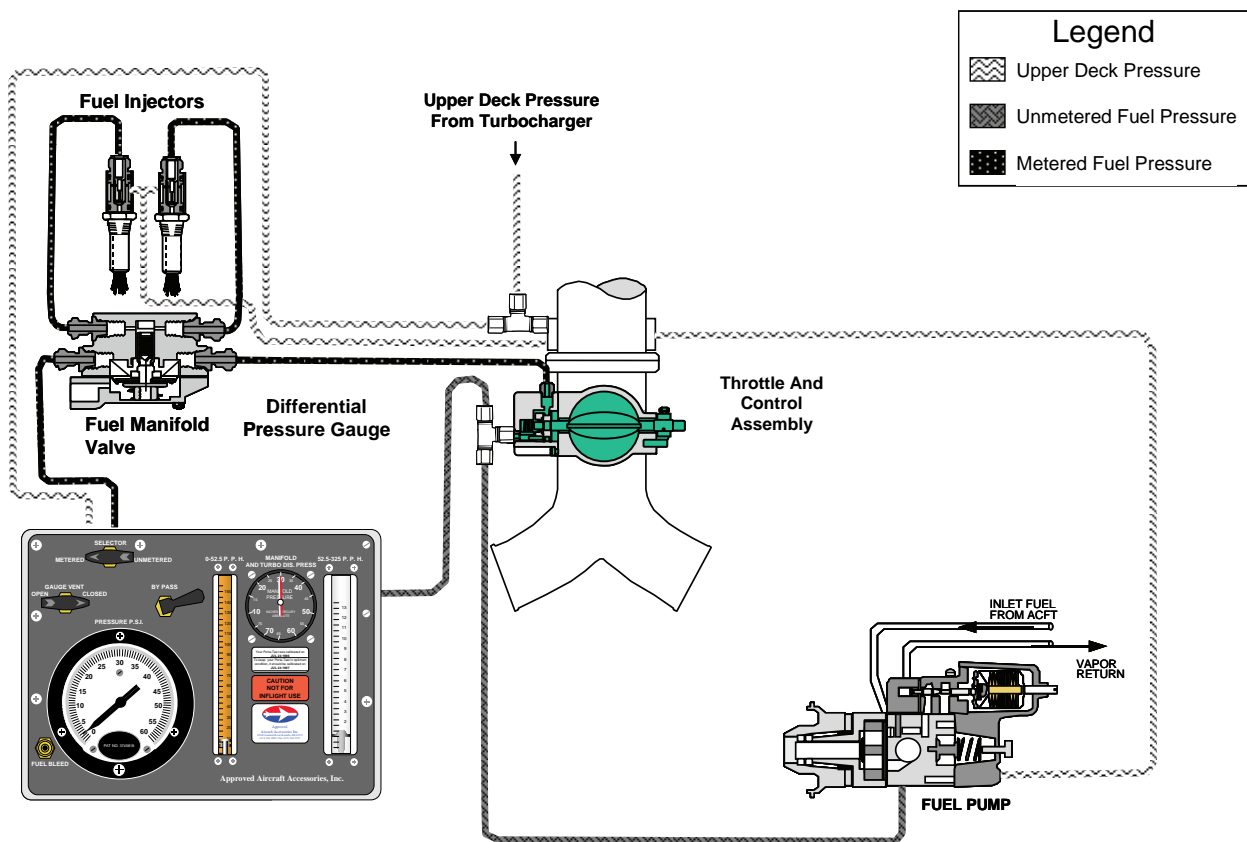

Figure 5-8. Porta-Test Connections

### 5-2.6.1.2. Calibrated Gauge Connections

1. Loosen the unmetered fuel supply hose from either the fuel pump outlet fitting or the fuel control inlet fitting, depending on access to connections.
2. Connect the MS51523-B4 swivel tee to the fuel connection loosened in step 1.

NOTE: Some installations may require a number of fittings to adapt the metered and unmetered test equipment to the fuel injection system.

3. Connect the unmetered fuel supply hose to the straight end of the tee connector.
4. Connect the 0-60 psi unmetered gauge to the tee connector with a hose.
5. Remove the cap from the metered fuel port fitting on the fuel manifold valve.
6. Disconnect an upper deck pressure fitting at the throttle body or intake manifold. Install an MS51523-B4 swivel tee inline with the upper deck pressure fittings.
7. Connect two equal lengths of hose to the 0-30 psid differential pressure gauge.
  - a. Connect the pressure hose from the differential pressure gauge to the metered pressure fuel port on the fuel manifold valve fitting.
  - b. Connect the “suction” side hose to the tee installed in the upper deck pressure pressure line installed in step 6.
8. Torque all connections according to Appendix B.
9. Position the throttle control to the FULL OPEN position and the mixture control to FULL RICH. Operate the aircraft boost pump in accordance with the aircraft manufacturer’s instructions.

NOTE: Gauges must remain at the same height or above the fuel injection system components under test for the duration of the operational check. Indicated fuel pressure at the gauge will increase if the gauges are below the fuel injection system, causing erroneous indications.

10. Loosen the test connections at each gauge to bleed the lines of air. Hold the gauge at, or slightly above, the height of fuel system components to allow the fuel to force the air out of the lines. Operate the boost pump only long enough to purge the air from the fuel system. Torque all loosened fittings in according to Appendix B.

#### **WARNING**

**Drain all fuel from the induction system prior to attempting engine start. Failure to comply may result in hydraulic lock and subsequent engine failure.**

11. Install the engine cowling or cooling shroud during ground operation.
12. Proceed to Section 5-2.6.2.



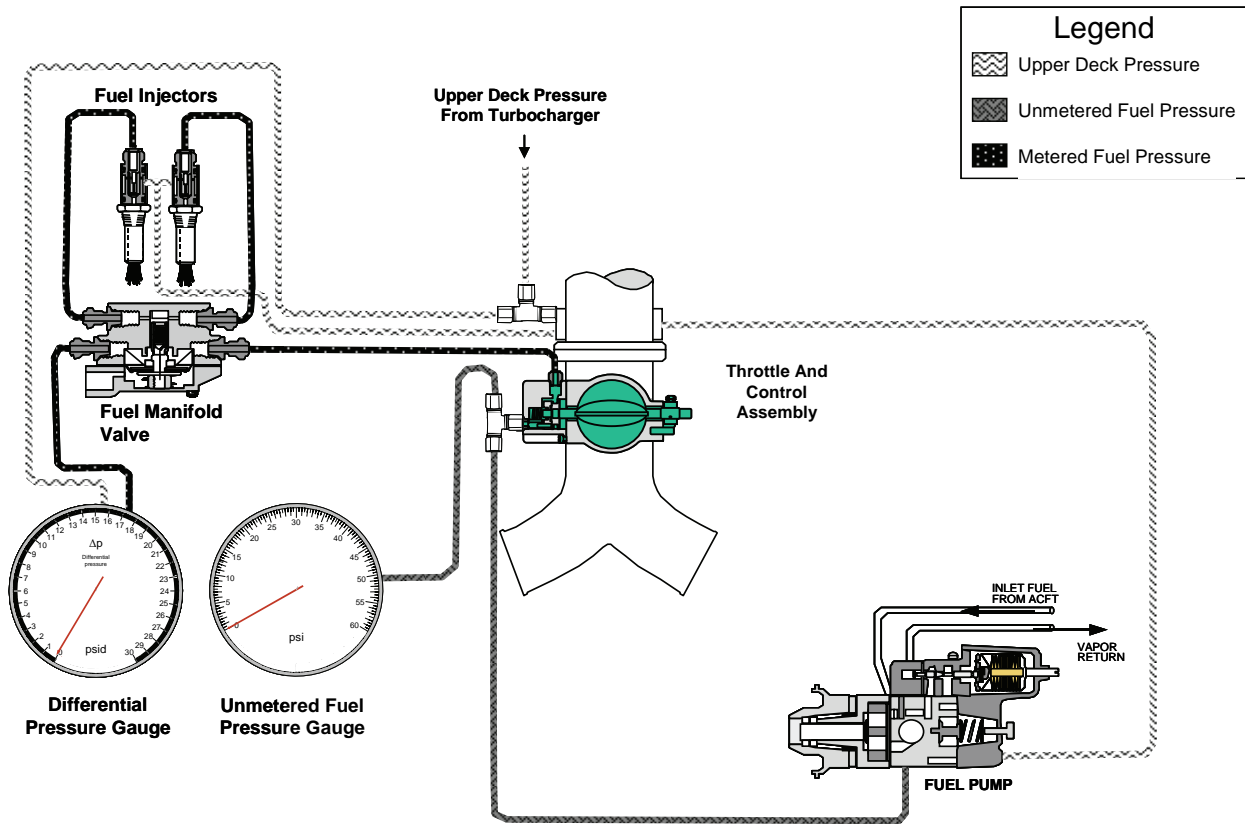

Figure 5-9. Fuel Injection System Gauge Hookup

### 5-2.6.2. Engine Operational Check

#### WARNING

Ensure the propeller arc is clear of personnel and obstructions before starting the engine.

Make all adjustments with the engine stopped and the Ignition Switch in the OFF position.

The following procedures apply to TCM fuel injected engines in their original type design. For modified engine designs, refer to the Supplemental Type Certificate holder instructions.

NOTE: A small puff of smoke emitted from the engine immediately upon engine start-up on a new or rebuilt engine, or an engine returned from storage, is normal. The smoke is the result of the remaining preservation from the cylinders, induction system, and/or fuel nozzles/lines burning in the combustion chamber; the smoke should quickly dissipate. If the smoke persists, shut down the engine (see “Engine Shutdown” in Chapter 7).

NOTE: Fuel system adjustments are interactive. Once begun, perform the entire procedure for proper fuel injection system operation.

1. Verify the accuracy of the tachometer, manifold pressure gauge and fuel flow gauges prior to making any adjustments; replace faulty gauges.
2. Locate the IDLE speed stop screw (Figure 5-10) on the throttle body and turn it counter-clockwise two complete turns. During the operational check, IDLE RPM will be controlled manually using the cockpit throttle control.

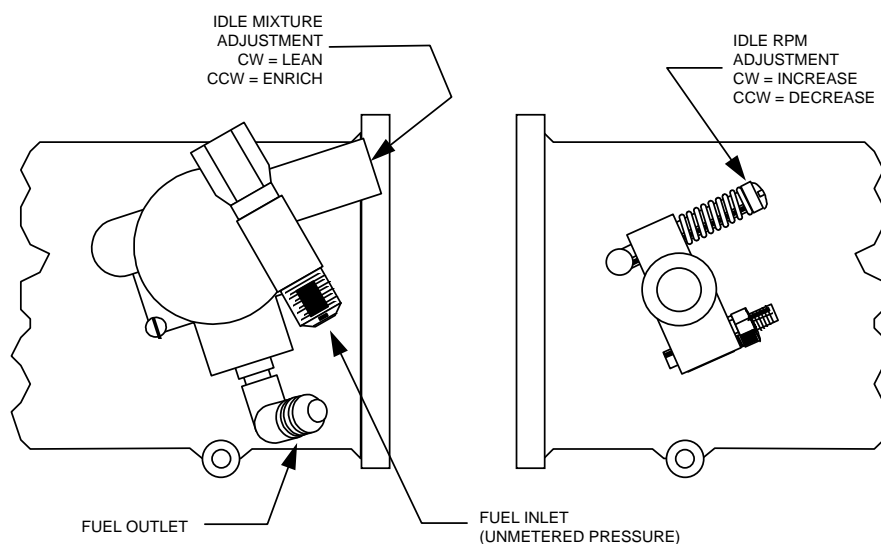

**Figure 5-10. Throttle Body Adjustments**



- 3. Fuel Selector Valve.....ON
- 4. Mixture Control .....FULL RICH
- 5. Boost Pump.....ON
- 6. Start the engine according to the “Engine Start” instructions in Chapter 7.
- 7. Throttle.....750 RPM (One minute)

*CAUTION: Operating the engine without oil pressure will result in engine malfunction or stoppage.*

RESULT: Allow the engine to run at 750 RPM for one minute. Gradually increase engine speed to 1000 RPM. Record the engine oil pressure. If no oil pressure is noted, shut down the engine and investigate the cause. If necessary, adjust the oil pressure:

NOTE: Allow the engine oil to reach normal operating temperature (100°F) before proceeding to the next step.

**WARNING**

**Make all adjustments with the engine stopped and the Ignition Switch in the OFF position.**

- a. Loosen the lock nut securing the oil pressure adjustment screw at the base of the oil pump.
- b. Adjust oil pressure to maintain 30-60 psi at full power RPM. To *increase* oil pressure, turn the oil pressure adjusting screw *clockwise* (CW) (Figure 5-11). To *decrease* oil pressure, turn the oil pressure adjusting screw *counterclockwise* (CCW).
- c. Torque the lock nut to Appendix B specifications and safety wire according to Appendix C.

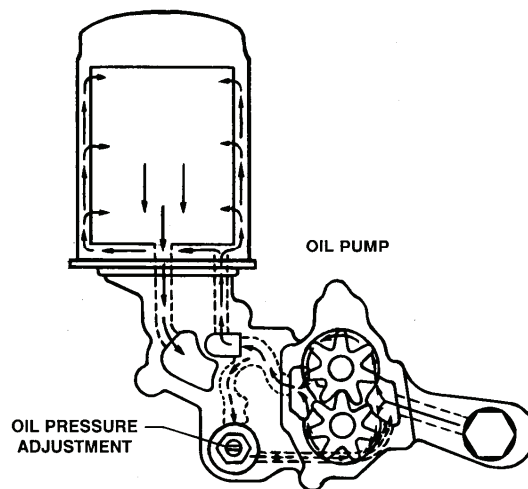

**Figure 5-11. Adjustment Screw on the Oil Pressure Relief Valve**

8. Operate the engine at 750 RPM (idle speed) for 1 minute, gradually increasing the speed to 1000 RPM in 3 minutes.
9. Boost Pump.....OFF
10. Mixture Control .....FULL RICH
11. Throttle.....600 ± 25 RPM
12. Unmetered fuel pressure gauge.....Check

RESULT: Check the unmetered fuel pressure on the test equipment. Adjust the unmetered fuel pressure to the setting specified in Table 5-4:

**WARNING**

**Make all adjustments with the engine stopped and the Ignition Switch in the OFF position.**

- a. Loosen the lock nut on the Low Pressure Relief Valve Assembly located at the rear of the fuel pump (see Figure 5-12).
- b. Adjust relief valve clockwise (CW) to increase unmetered fuel pump pressure, or counter-clockwise (CCW) to decrease unmetered fuel pump pressure.
- c. Operate the engine at 1500-1800 RPM for 15 seconds after each adjustment, then retard the throttle to 600 RPM to obtain accurate fuel pump pressure readings.
- d. Repeat steps a-c until the unmetered fuel pump pressure reading is between 7.00 - 9.00 psig for the idle fuel pump pressure requirement.

NOTE: Set IDLE RPM unmetered pump pressure to the minimum limit for slight fuel enrichment during part throttle operations.

- e. Torque lock nut according to Appendix B specification. Check reading again as in step c to ensure tightening the lock nut did not affect relief valve setting.

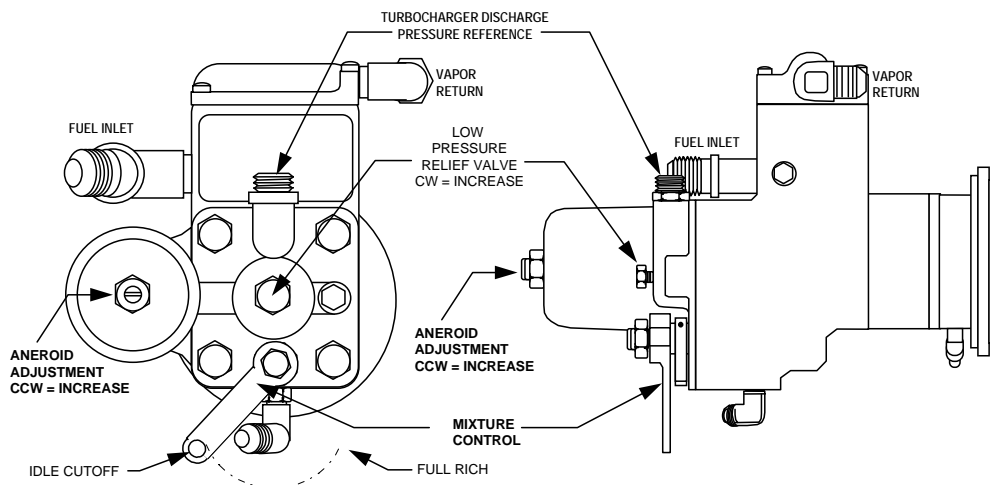

**Figure 5-12. Fuel Pump Adjustments**



13. Throttle.....1500-1800 RPM

RESULT: Maintain engine speed until CHT is 250°F to 350°F and engine oil temperature is 160°F to 180°F.

14. Throttle.....600 ± 25 RPM

15. Mixture Control .....Retard slowly  
toward IDLE/CUTOFF

RESULT: The engine speed should increase 25 to 50 rpm before beginning to drop toward zero. If the engine speed increase is less that 25 rpm, the mixture is too lean. If the engine speed increases more that 50 rpm, the mixture is too rich. Adjust the mixture as required:

**WARNING**

**Make all adjustments with the engine stopped and the Ignition Switch in the OFF position.**

- a. Turn the idle mixture adjustment clockwise (see Figure 5-10) (CW) to lean the mixture setting and counter clockwise (CCW) to enrich the mixture setting. Restart the engine and check as required to ensure the idle mixture is adjusted within the limits specified. Each time an adjustment is made, clear the engine by running it up to approximately 1500 - 1800 rpm before making another mixture check.

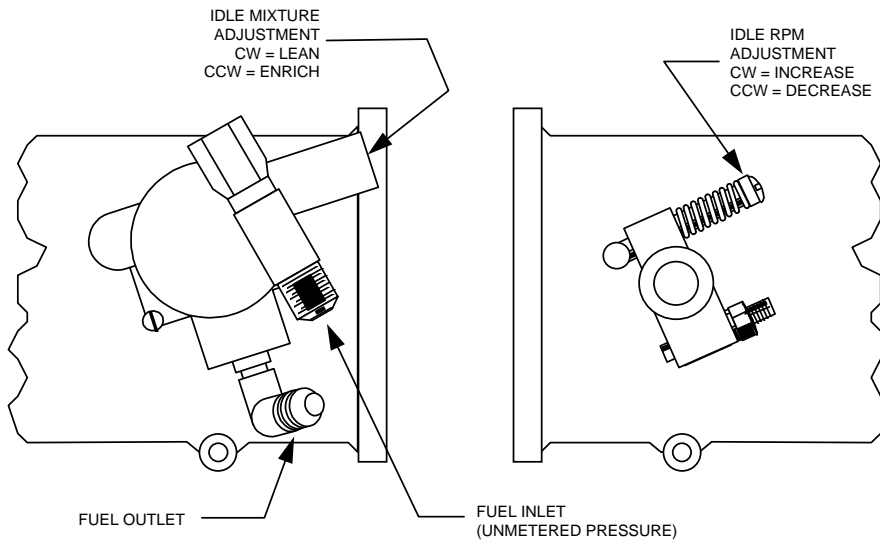

**Figure 5-10 repeated for reference**

16. Mixture Control .....FULL RICH

17. Propeller Governor.....WIDE OPEN

18. Throttle.....WIDE OPEN

RESULT: Check the engine RPM with a portable tachometer. Record the engine speed on the checklist. If the engine does not reach the rated propeller RPM, calculate the corrected meter pressure (Table 5-5).

19. Metered Pressure Gauge .....Check

RESULT: Verify the manifold pressure is within the limit specified in Table 5-4. If adjustments are necessary, refer to “Sloped Controller Adjustment” in Chapter 9 of the Maintenance and Overhaul Manual (M-18). The full power metered fuel pressure should equal the value in Table 5-4, with Table 5-5 correction factor, if applicable.

**WARNING**

**Make all adjustments with the engine stopped and the Ignition Switch in the OFF position.**

20. Loosen the lock nut (Figure 5-12) on the aneroid housing.
21. Turn aneroid adjustment screw clockwise (CW) to decrease full power metered fuel pump pressure; turn the screw counter-clockwise (CCW) to increase full power metered fuel pump pressure.

*CAUTION: Over-torquing the lock nut on the aneroid housing will damage the aneroid housing threads.*

22. After final adjustment, torque the lock the nut according to Appendix B specifications. Do not exceed lock nut torque limits.
23. Recheck the IDLE RPM unmetered fuel pressure and fuel/air mixture. If values are not within specified limits, repeat the adjustment procedures until all settings are within specified limits.

24. Throttle.....IDLE/CUTOFF

25. Adjust the idle speed screw, located on the aft side of the throttle lever (Figure 5-10), until contact is made with the throttle arm stop. Turn the idle speed screw in one of the following directions until the IDLE RPM
- a. Clockwise (CW) to increase idling speed.
  - b. Counter-clockwise (CCW) to decrease idling speed.

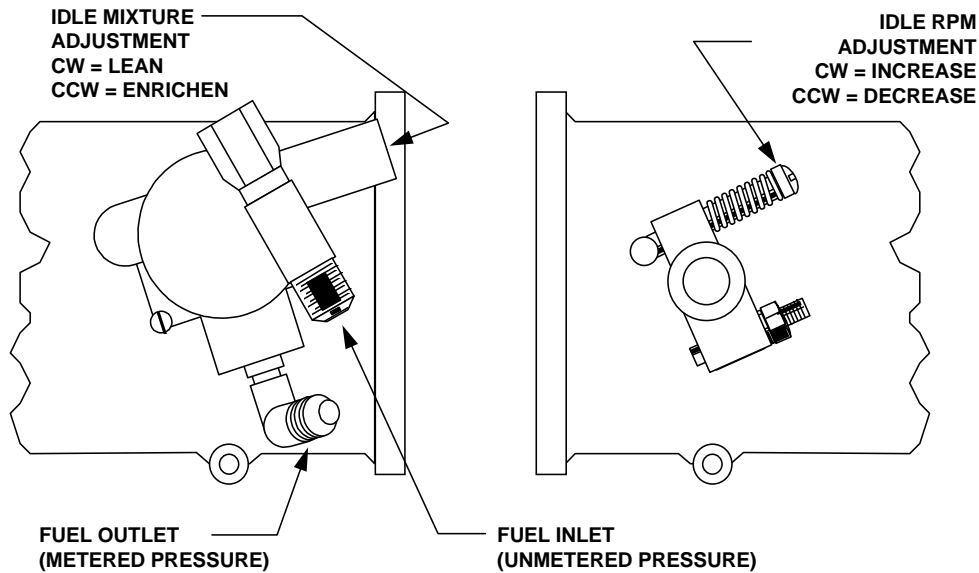

Figure 5-10 repeated for reference

26. Perform a normal engine shutdown according to the “Engine Shutdown” instructions in Chapter 7.
27. Remove installed test equipment
  - a. Disconnect the metered fuel pressure hose from the aircraft fittings.
  - b. Disconnect the unmetered fuel pressure hose from between the fuel pump and the fuel control assembly.
  - c. Disconnect the upper deck pressure reference hose installed at the throttle body.
  - d. Remove any fittings added to adapt the plumbing to the test equipment.
28. Reconnect and torque the fuel system hoses according to Appendix B.
  - a. Connect the unmetered pressure hose between the fuel pump and the fuel control assembly.
  - b. Install the protective cap (or airframe-installed fitting to cockpit metered pressure gauge) on the fuel manifold valve (metered pressure) fitting.
  - c. Connect the upper deck pressure fitting to the throttle body.
29. Boost Pump.....ON  
RESULT: Check for fuel leaks, particularly around the fittings and hoses connected in step 28 and correct any discrepancies before releasing the engine for flight:
30. Boost Pump.....OFF
31. Check for oil leaks around the engine nacelle, oil hoses and fittings
32. If a compressor drive belt is installed, after approximately 5 hours of operation, check the tension on the compressor drive belt. Adjust the drive belt as required per instructions in the “Drive Belt Installation and Tension Adjustment” section of “Maintenance and Adjustments” in Chapter 9.



### **5-2.6.3. Operational Checklist**

Make a copy of the Operational Checklist to record operational test results.

NOTE: Operating limits and model specifications for this engine are located in Chapter 2, Engine Description of this manual.







*This Page Intentionally Left Blank*



## 5-3. Unscheduled Maintenance

### 5-3.1. Propeller Strike

A propeller strike is any incident (whether or not the engine is operating) which either requires repair to a propeller blade (other than minor dressing of the blade) or where the propeller makes contact with any object that results in the loss of engine RPM.

Propeller strikes against the ground or any object can cause engine and component damage even though the propeller still may continue to rotate. This damage can result in catastrophic engine failure.

#### **WARNING**

**Do not attempt to dress a propeller blade without consulting the propeller manufacturer's instructions. Stresses imposed on the propeller are more concentrated in areas that are nicked and cut that then act as stress risers. Stress risers can weaken the blade and may eventually cause the blade to fail. If a propeller blade is lost, the resulting imbalance can cause separation of the entire engine from the airframe causing the center of gravity to extend beyond specified limits rendering the aircraft uncontrollable.**

In cases where a small foreign object such as a small stone, strikes the propeller during operation, inspect and repair the propeller in accordance with the propeller manufacturer's instructions. Any time foreign object damage requires removal of the propeller for repair(s) other than minor dressing of the blades, adhere to the procedure in the section "Propeller Strike Inspection" in the TCM Maintenance and Overhaul Manual (M-18).

Recommended remedial action for a propeller strike includes a complete engine teardown and inspection of all rotating engine components, replacement of all counterweight pins, bushings, end plates, and snap rings and reassembly.

### 5-3.2. Hydraulic Lock

#### **WARNING**

**If hydraulic lock is encountered, cease engine operation until a hydraulic lock inspection is performed.**

Hydraulic lock is a condition where fluid accumulates in the Induction System or the cylinder assembly. The liquid restricts the piston from traveling during the compression stroke. Damage to the engine occurs when the other cylinders fire which forces the piston in the fluid filled cylinder through the compression stroke. Damage to an engine from hydraulic lock can be extensive due to the high stresses generated. A hydraulic lock inspection includes engine cylinder disassembly, connecting rod inspection and correction of any discrepancies discovered.

### 5-3.3. Engine Overspeed

Operating an engine beyond its capacity can damage the engine and result in subsequent engine failure. TSIO-550 overspeed conditions have three levels of severity defined in the table below:

| Category | Engine Speed    |
|----------|-----------------|
| CAT I    | Up to 3000 RPM  |
| CAT II   | 3000 – 3300 RPM |
| CAT III  | Over 3300 RPM   |

NOTE: The rated RPM limit for aircraft equipped with digital RPM measuring equipment may be established to include a +2% variance for normal operations. Any operation beyond the rated RPM limit plus the 2% variation must follow the inspection criteria.

#### 5-3.3.1. Category I Overspeed Inspection

If engine overspeed continues uncorrected for less than ten seconds, no action is required. If the overspeed continues for longer than 10 seconds, land the plane. Drain the oil, remove the filter and inspect for debris. Remove the rocker covers and inspect the valve train for damage. Inspect the accessory drives for excessive backlash. Change the oil and repeat the inspection after five hours of flight.

#### 5-3.3.2. Category II Overspeed Inspection

Complete all Category I requirements. Remove all cylinder assemblies, including pistons and rods. Remove and inspect all counterweights. Replace all connecting rod nuts and bolts. Inspect remaining components using service limit tolerances and assemble according to instructions in the Maintenance and Overhaul Manual (M-18).

#### 5-3.3.3. Category III

Remove the engine and clearly identify the reason for removal as, “Removed for excessive overspeed.” Perform a complete engine overhaul, replacing the connecting rods, connecting rod bolts and nuts and all valve train components.

### 5-3.4. Turbocharger Overboost

Erratic throttle movement, especially during takeoff and landing may cause the turbocharger to exceed engine manifold pressure limits, a condition referred to as “overboost”. For overboost below 3 in. Hg., slower throttle movement will prevent future occurrences.

1. Turbocharger overboost events between 3 and 6 in. Hg. are an indication of a hardware malfunction or improper control calibration. Troubleshoot and correct the problem before further flight.
2. Turbocharger overboost beyond 6 in Hg. is an indication of a serious malfunction. Engine damage is likely and must be assessed. Contact TCM for instructions.



### **5-3.5. Lightning Strike**

A High Voltage Damage Assessment includes complete engine disassembly and inspection of the engine for arcing and heat damage to the crankshaft rod journals, main journals, counterweights, camshaft lobes, bearings, gear teeth, and all other hardened surfaces. Magnaflux and degauss the steel parts of the engine during the inspection.

### **5-3.6. Contaminated Fuel System**

The engines described in this manual are certified for operation with 100-LL Blue or 100 Green aviation fuels. If a lower octane or incorrect grade of aviation fuel or jet fuel is used, do not fly the aircraft. Drain the fuel system completely. Service the fuel tanks in accordance with the aircraft manufacturer's instructions. Disassemble, clean, and inspect the engine in accordance with instructions in TCM's Maintenance and Overhaul Manual (M-18) for this engine. Inspect and purge the aircraft fuel tanks and fuel lines of all contamination to prevent malfunction of the Fuel Injection System and damage to its components.

### **5-3.7. Abnormal Ferrous Material in Oil Analysis**

See "Excessive or Abnormal Engine Noise."

### **5-3.8. Excessive or Abnormal Engine Noise**

If abnormal noise is coming from the engine valve gear or if abnormal amounts of iron and/or steel are detected by oil analysis, oil filter element or screen examination, oil suction screen examination, or magnetic drain plug examination, TCM recommends a lifter and camshaft lobe inspection. This is not a scheduled inspection and only required if audible noise from the valve gear.



*This Page Intentionally Left Blank*



---

## **Chapter 6. ENGINE PRESERVATION AND STORAGE**

### **CONTENTS**

|  |            |
|--|------------|
| <b>Chapter 6. Engine Preservation and Storage.....</b>   | <b>6-1</b> |
| 6-1. Preserving and Storing the Engine .....             | 6-2        |
| 6-1.1. New or Unused Engine Storage.....                 | 6-2        |
| 6-1.2. Temporary Storage .....                           | 6-2        |
| 6-1.3. Indefinite Storage .....                          | 6-4        |
| 6-1.4. Returning an Engine to Service after Storage..... | 6-6        |
| 6-2. Engine Preservation Checklist.....                  | 6-6        |

### **LIST OF TABLES**

|   |     |
|---|-----|
| Table 6-1. Engine Preservation Checklist..... | 6-7 |
|---|-----|

## 6-1. Preserving and Storing the Engine

Typically an engine that has been uncrated and is not installed and/or operated within 30 days after uncrating should be placed in storage. There are separate instructions for temporary (from 30 days up to 90 days) and indefinite (90 days or more) storage.

### 6-1.1. New or Unused Engine Storage

1. Determine the projected length of storage and refer to the respective section for preservation and storage instructions.
  - a. If the engine storage period is *less* than 90 days, follow the instructions in “Temporary Storage.”
  - b. If the engine will be stored for *more* than 90 days, follow the instructions in “Indefinite Storage.”
2. After preservation, cover the engine with a plastic bag.
3. Install and attach the container cover to the base (if not already done).

### 6-1.2. Temporary Storage

TCM defines temporary storage as a period of 30 to 90 days when the engine will not be used. If the storage period is likely to exceed 90 days, prepare the engine for long term storage according to instructions in “Indefinite Storage.”

#### **WARNING**

**Perform this procedure in an area free of sparks, flames or any form of ignition that will support combustion.**

1. Perform an oil change according to “Engine Oil Servicing” instructions in Chapter 5, “Inspection and Service” of this manual. Service the engine to the proper sump capacity with oil conforming to MIL-C-6529 Type II (Break-in oil – SAEJ 1966 non-dispersant mineral oil).

#### **WARNING**

**If preheaters are used to warm the engine, do not leave preheaters on for longer than 24 hours to prevent corrosion.**

2. Perform a ground run-up.
3. Perform a preflight inspection. Correct any discrepancies.
4. Fly the aircraft for 1 hour at normal operating temperatures.
5. Allow the engine to cool after flight.





**WARNING**

**Before moving the propeller:**

- **Disconnect all spark plug leads.**
- **Verify the magneto switches are connected to the magnetos, in the OFF position, and “P” leads are grounded.**
- **Position the throttle to the CLOSED position.**
- **Set the mixture control to “IDLE/CUTOFF.”**
- **Set the brakes and block the aircraft wheels. Install aircraft tie-downs.**
- **Do not stand or place equipment within the arc of the propeller**

6. Disconnect and remove all spark plug leads.
7. Remove the top six spark plugs.
8. Cover the ignition lead ends with AN-4060 protectors.
9. With the piston at the bottom dead center position, use a common garden sprayer with clean reservoir and nozzle to spray atomized cylinder preservation oil that meets MIL-P-46002, Grade 1 through the upper spark plug hole of each engine cylinder, with the pistons at bottom dead center. Rotate the crankshaft as opposite cylinders are sprayed.
10. Stop the crankshaft at a position where no pistons are at top dead center.
11. Spray each cylinder again; thoroughly coat all interior cylinder surfaces by moving the nozzle from top to bottom of the cylinder while spraying. When all cylinders walls are thoroughly coated, ensure no piston is positioned at top dead center.
12. Install the top spark plugs. Do not install the spark plug leads.
13. Seal all engine openings exposed to the atmosphere using suitable plugs and covers. Attach a “REMOVE BEFORE FLIGHT” streamer to each location.
14. Attach a tag in a prominent location on the engine, preferably the propeller (or storage container if uninstalled) with the following information:

*DO NOT TURN PROPELLER – ENGINE PRESERVED  
(Preservation date)*

15. Indicate the status of new or rebuilt engines which have not been placed in service on the preservation tag.

NOTE: If the engine is not returned to service within 90 days of initial short term preservation, it must be preserved in accordance with “Indefinite Storage” procedures.

### 6-1.3. Indefinite Storage

**WARNING**

**Perform this procedure in an area free of sparks, flames or other ignition sources.**

1. Perform an oil change according to “Engine Oil Servicing” instructions in Chapter 5, “Inspection and Service” of this manual. Service the engine to the proper sump capacity with oil conforming to MIL-C-6529 Type II (Break-in oil – SAEJ 1966 non-dispersant mineral oil).

**WARNING**

**If preheaters are being used to warm up a cold engine, do not leave preheaters on for more than 24 hours prior to flight to prevent corrosion.**

2. Perform a ground run-up.
3. Perform a pre-flight inspection. Correct any discrepancies.
4. Fly the aircraft for 1 hour at normal operating temperatures.
5. After flight, allow the engine to cool.
6. Disconnect and remove all spark plug leads.
7. Remove all spark plugs.
8. Cover the ignition lead ends with AN-4060 protectors.
9. Install protective plugs (P/N 22671) in the bottom spark plug holes.

**WARNING**

**Before moving the propeller:**

- **Disconnect all spark plug leads.**
  - **Verify the magneto switches are connected to the magnetos, in the OFF position, and “P” leads are grounded.**
  - **Position the throttle to the CLOSED position.**
  - **Set the mixture control to “IDLE/CUTOFF.”**
  - **Set the brakes and block the aircraft wheels. Install aircraft tie-downs.**
  - **Do not stand or place equipment within the arc of the propeller**
10. With the piston at bottom dead center position, use a common garden sprayer with clean reservoir and nozzle to spray atomized cylinder preservation oil that meets MIL-P-46002, Grade 1 through the upper spark plug hole of each engine cylinder, with the pistons at bottom dead center. Rotate the crankshaft as opposite cylinders are sprayed.



11. Spray each cylinder again; thoroughly coat all interior cylinder surfaces by moving the nozzle from top to bottom of the cylinder while spraying. When all cylinder walls are thoroughly coated, ensure no piston is positioned at top dead center.
12. Install dehydrator plugs MS27215-1 or MS27215-2 in each of the top spark plug holes. Make sure that each plug is dark blue in color when installed.
13. Attach a “REMOVE BEFORE FLIGHT” streamer tag to each bag of desiccant and place the tagged desiccant bag in the exhaust pipes. Seal the exhaust pipe openings.
14. Seal all other exposed engine openings using suitable plugs and covers.
15. Affix a readily visible tag on each propeller with the following information:

*DO NOT TURN PROPELLER – ENGINE PRESERVED  
(Preservation Date)*
16. Indicate the status of new or rebuilt engines which have not been placed in service on the preservation tag.
17. Make a copy of the “Engine Preservation Checklist” at the end of this chapter. Enter the serial number, storage date and next inspection due date. Attach the form to the engine.
18. For indefinite storage, visually inspect the dehydrator plugs at 15-day intervals. Change the plugs at the first indication of a color change. (If any plug is not dark blue, replace with a new plug). If over half of the dehydrator plugs change color, replace all desiccant material on the engine.
19. Spray the cylinders walls with preservative oil at 90-day intervals.



### 6-1.4. Returning an Engine to Service after Storage

1. Remove seals and desiccant bags.
2. Remove cylinder dehydrators and plugs from upper and lower spark plug holes.
3. Perform an oil change according to “Engine Oil Servicing” instructions in Chapter 5, “Inspection and Service” of this manual. Service the engine to the proper sump capacity with oil conforming to MIL-C-6529 Type II (Break-in oil – SAEJ 1966 non-dispersant mineral oil).

#### **WARNING**

##### **Before moving the propeller:**

- **Disconnect all spark plug leads.**
  - **Verify the magneto switches are connected to the magnetos, in the OFF position, and “P” leads are grounded.**
  - **Position the throttle to the CLOSED position.**
  - **Set the mixture control to “IDLE/CUTOFF.”**
  - **Set the brakes and block the aircraft wheels. Install aircraft tie-downs.**
  - **Do not stand or place equipment within the arc of the propeller**
4. Rotate propeller several revolutions by hand to remove preservative oil.
  5. Service and install spark plugs and leads in accordance with Chapter 5, “Spark Plug Installation” and “Ignition Harness Installation.”
  6. Clean and service engine and aircraft in accordance with airframe manufacturer’s instructions. Perform a visual inspection and correct any discrepancies noted.
  7. Perform a normal engine start in accordance with the Airplane Flight Manual or Pilot’s Operating Handbook.
  8. Conduct an “Engine Operational Check” in accordance with Chapter 5, “Inspection and Service.” Correct any discrepancies
  9. Perform a “Flight Check” in accordance with Chapter 7 and correct any discrepancies before releasing the aircraft for normal service.
  10. Change engine oil and filter after first 25 hours of operation.

### 6-2. Engine Preservation Checklist

Make a copy of the checklist and complete this checklist for each engine placed in long-term storage. Starting from the first day of storage, fill in the actual calendar date in the “Inspection Due Date” column in this checklist. This checklist covers a 90-day storage cycle. Complete a new checklist for each 90-day cycle of storage and attach to the previous checklist as a record to help track inspections.



| Table 6-1. Engine Preservation Checklist   |  |                                |                 |              |
|--|--|--------------------------------|-----------------|--------------|
| Serial Number(s) of Engine in Storage:   |  | Date Engine placed in Storage: |                 |              |
| Inspection Item  | STATUS   | Inspection Due Date            | Completion Date | Performed By |
| Engine preserved and stored IAW "Indefinite Storage" procedure.  | <input type="checkbox"/> YES   | ---                            |                 |              |
| 15 day inspection *  | <input type="checkbox"/> PASSED<br><input type="checkbox"/> CORRECTED    |                                |                 |              |
| 30 day inspection *  | <input type="checkbox"/> PASSED<br><input type="checkbox"/> CORRECTED    |                                |                 |              |
| 45 day inspection *  | <input type="checkbox"/> PASSED<br><input type="checkbox"/> CORRECTED    |                                |                 |              |
| 60 day inspection *  | <input type="checkbox"/> PASSED<br><input type="checkbox"/> CORRECTED    |                                |                 |              |
| 75 day inspection *  | <input type="checkbox"/> PASSED<br><input type="checkbox"/> CORRECTED    |                                |                 |              |
| 90 day inspection *  | <input type="checkbox"/> PASSED<br><input type="checkbox"/> CORRECTED    |                                |                 |              |
| 90 day cylinder treatment **   | <input type="checkbox"/> PASSED<br><input type="checkbox"/> CORRECTED    |                                |                 |              |
| Engine(s) removed from storage   | <input type="checkbox"/> YES<br><input type="checkbox"/> TRANSFER RECORD | ---                            |                 |              |
| <p>* Check condition of dehydrator plug for discoloration. Contents should be dark blue in color. If plugs are discolored, remove and replace with new plugs. If more than half the dehydrator plugs on the engine require replacement, remove and replace the desiccant bags in the exhaust pipes with fresh desiccant bags and reseal the exhaust pipe.</p> <p>** Treat each cylinder bore with MIL-P-46002, Grade 1. With the piston at the bottom dead center position, use a clean garden sprayer to spray atomized cylinder preservation oil that meets MIL-P-46002, Grade 1 (at room temperature) through the upper spark plug hole of each engine cylinder. Thoroughly cover all interior cylinder surfaces by moving the nozzle from top to bottom. Rotate the crankshaft as opposite cylinders are sprayed. Leave no piston positioned at top dead center.</p> |  |                                |                 |              |
| Inspector Notes:   |  |                                |                 |              |



*This Page Intentionally Left Blank*



# Chapter 7. ENGINE OPERATION

## CONTENTS

**Chapter 7. Engine Operation..... 7-1**

7-1. Introduction ..... 7-2

7-2. Flight Prerequisites ..... 7-2

    7-2.1. Oil Change Interval ..... 7-3

    7-2.2. Engine Fuel Requirements..... 7-3

    7-2.3. Flight Check and Break-In..... 7-3

7-3. Normal Operation ..... 7-6

    7-3.1. Pre-operational Requirements ..... 7-6

    7-3.2. Engine Start ..... 7-7

    7-3.3. Ground Warm-up..... 7-9

    7-3.4. Taxi Preparation ..... 7-9

    7-3.5. Power Control..... 7-11

    7-3.6. Take-Off/Climb ..... 7-12

    7-3.7. Cruise Climb..... 7-12

    7-3.8. Cruise..... 7-13

    7-3.9. Descent ..... 7-15

    7-3.10. Landing..... 7-15

    7-3.11. Engine Shutdown..... 7-16

7-4. Emergency Operation ..... 7-18

    7-4.1. Engine Fire during Start..... 7-18

    7-4.2. Engine Roughness ..... 7-18

    7-4.3. Turbocharger Failure ..... 7-19

    7-4.4. High Cylinder Head Temperature..... 7-20

    7-4.5. High Oil Temperature..... 7-20

    7-4.6. Low Oil Pressure ..... 7-21

    7-4.7. In-Flight Restart..... 7-21

    7-4.8. Engine Fire In-Flight ..... 7-21

7-5. Engine Operation in Abnormal Environments ..... 7-22

    7-5.1. Engine Operation in Extreme Cold..... 7-22

    7-5.2. Engine Preheating..... 7-23

    7-5.3. Engine Operation in Hot Weather ..... 7-29

    7-5.4. Ground Operation at a High Density Altitude ..... 7-31

7-6. Troubleshooting..... 7-32

    7-6.1. General ..... 7-32

    7-6.2. Lubrication System..... 7-34

    7-6.3. Ignition Harness and Spark Plug Diagnostics..... 7-36

## LIST OF TABLES

Table 7-1. TSIO-550 Engine Operating Limits ..... 7-5

## 7-1. Introduction

This chapter contains the following TSIO-550 Permold engine operating instructions:

- Flight Prerequisites
- Normal Operation
- Emergency Operation
- Operation in Abnormal Environments
- Troubleshooting

This chapter applies to TCM TSIO-550 operation with variable pitch propellers and supplements information in the Airplane Flight Manual (AFM) or Pilot's Operating Handbook (POH) provided by the airframe manufacturer or supplemental type certificate holder as required by the Federal Aviation Regulations (FAR) for aircraft operating procedures.

*CAUTION: This section pertains to engine operations under various operating conditions. Normal operations are presented first, followed by emergency and abnormal operating conditions. The pilot must read and thoroughly understand sections 7-4 and 7-5 prior to the occurrence of such conditions. Whenever abnormal conditions arise, timely response is critical.*

## 7-2. Flight Prerequisites

If the engine is newly installed and/or has been repaired/overhauled, perform the tasks listed in the Engine Operational Check section of Chapter 5 prior to releasing the engine for normal operation.

### **WARNING**

**The Operational Checks listed in Chapter 5, Inspections and Service must be completed on an engine that has been installed, inspected, repaired, or overhauled before the aircraft is authorized for flight.**

**DO NOT FLY THE AIRCRAFT UNTIL ALL FLIGHT PREREQUISITES HAVE BEEN MET.**

NOTE: Environmental conditions (humidity), seasonal changes, and engine usage influence susceptibility to corrosion. Engines that are flown occasionally (less than one time per week) are more vulnerable to corrosion under these conditions. The best method of reducing the risk of corrosion is to fly the aircraft weekly for at least one hour. The owner/operator is ultimately responsible for recognizing corrosion and taking appropriate corrective action.

After completing all of the tasks in Chapter 5 of this manual, perform a flight check, as instructed in the "Flight Check" section in this chapter.





### 7-2.1. Oil Change Interval

NOTE: After the first 25 hours of operation, perform an oil change according to the instructions in the “Engine Oil Servicing” section of Chapter 5, in this manual.

The oil change interval is specified in Chapter 5, section 5-1.1.

### 7-2.2. Engine Fuel Requirements

#### **WARNING**

**The engine is certified for operation with 100-LL Blue or 100 Green aviation fuels. If the minimum grade required is not available, use the next higher grade. Never use a lower grade fuel. The user of lower octane rated fuel will result in damage to, or destruction of, an engine the first time high power is applied.**

If the aircraft is inadvertently serviced with the wrong grade of aviation fuel or jet fuel is used, the fuel system must be completely drained and the fuel tanks serviced in accordance with the aircraft manufacturer’s recommendations. After the fuel system is decontaminated, the engine must be inspected in accordance with “Contaminated Fuel System” inspections in Chapter 7 of TCM’s Maintenance and Overhaul Manual (M-18) for this engine.

### 7-2.3. Flight Check and Break-In

An Operational Inspection and a normal preflight ground run-up in accordance with the Airplane Flight Manual or Pilot’s Operating Handbook (AFM/POH) must be completed before the A&P mechanic can approve the airplane for a Flight Check. A Flight Check is required after engine installation, inspection, repairs, or adjustments. Follow these parameters for the first 25 hours of operation to complete the recommended break-in for TCM engines.

New and rebuilt engines shipped by TCM are calibrated in a test cell prior to shipment. However, the flight check ensures the engine meets all operational parameters after installation and prior to release for normal service. Refer to “Engine Specifications and Operating Limits” in Chapter 2 specific limits for your engine model.

*CAUTION: High power ground operation resulting in cylinder and oil temperatures exceeding normal operating limits can be detrimental to cylinders, pistons, valves, and rings.*

1. Start the engine as instructed in the “Engine Start” section of this chapter.
2. Conduct a normal, take-off as directed in the “Taxi Preparation,” “Ground Warm-up,” and “Take-off” sections of this chapter.



3. Monitor the following engine operating indicators:
  - a. Engine RPM
  - b. Fuel flow
  - c. Oil pressure
  - d. Oil temperature
  - e. Cylinder Head Temperature
  - f. Turbine Inlet Temperature/Exhaust Gas Temperature
4. Reduce the engine speed to climb power in accordance with the airframe manufacturer's AFM/POH. Maintain a shallow climb attitude to achieve optimum airspeed and cooling airflow.
5. At cruise altitude:
  - a. Maintain level flight cruise at 75% power with best power or richer mixture for the first hour of operation.

NOTE: Best power mixture setting is 100°F-150°F rich of peak exhaust gas temperature. Adjust engine controls or aircraft attitude to maintain engine instrumentation within specification.

- b. During the second hour of flight, alternate power settings between 65% and 75% power with appropriate best power mixture settings.

**WARNING**

**Avoid long descents at high RPMs or low manifold pressure to prevent the engine from excessive cooling. If power must be reduced for long periods, adjust the propeller to minimum governing RPM and set the manifold pressure no lower than necessary to obtain desired performance.**

**If the outside air is extremely cold, it may be desirable to add drag to maintain engine power without gaining excess airspeed. Do not permit the cylinder temperature to drop below 300°F (149°C).**

6. Descend at low cruise power settings. Avoid long descents or descents with cruise power RPM and manifold pressure below 18 inches Hg. If necessary reduce engine RPM to the bottom of the specified operating range to maintain sufficient manifold pressure. Carefully monitor engine instrumentation to maintain levels above the minimum specified cylinder head temperature and oil temperature.

**WARNING**

**All abnormal conditions must be corrected prior to releasing the aircraft for normal operation.**

7. Correct any discrepancies prior to releasing the aircraft for service.



7-2.3.1.1. Flight Check Limits

Observe the following limits during the engine operation.

| Specification  | Limit  |                             |                             |                             |
|--|--|-----------------------------|-----------------------------|-----------------------------|
|  | B  | C                           | E                           | G                           |
| Full Throttle Speed ±25 RPM  | 2700   | 2600                        | 2700                        | 2700                        |
| Idle Speed RPM ± 25 RPM  | 600  | 600                         | 600                         | 600                         |
| Rated Manifold Air Pressure (full throttle@ sea level) ± 0.2 in. Hg  | 38.0   | 35.5                        | 38.5                        | 34.0                        |
| Engine Intake Air Temperature  | Ambient  | Ambient                     | Ambient                     | Ambient                     |
| Engine Intake Air Pressure   | Ambient  | Ambient                     | Ambient                     | Ambient                     |
| Fuel Grade (Octane)  | 100-LL Blue or 100 Green   | 100-LL Blue or 100 Green    | 100-LL Blue or 100 Green    | 100-LL Blue or 100 Green    |
| Unmetered Fuel Pump Pressure (Idle) (psi)  | 7.0-9.0  | 7.0-9.0                     | 7.0-9.0                     | 7.0-9.0                     |
| Metered Nozzle Pressure (psi)  | 15.3-16.9  | 12.7-13.9                   | 15.3-16.9                   | 12.4-13.6                   |
| Unmetered Fuel Pump Pressure (Full Power) (Reference) (psi)  | 32-36  | 26-29                       | 32-36                       | 20.5-23.5                   |
| Full Throttle Fuel Flow (lbs/Hr)   | 245-255  | 212-224                     | 245-255                     | 200-210                     |
| Oil Temperature (Minimum)  | 100°F (38°)  | 100°F (38°)                 | 100°F (38°)                 | 100°F (38°)                 |
| Oil Temperature (Maximum)  | 240°F (116°C)  | 240°F (116°C)               | 240°F (116°C)               | 240°F (116°C)               |
| Oil Pressure (Cold) (Maximum)  | 100 psig   | 100 psig                    | 100 psig                    | 100 psig                    |
| Oil Pressure (Minimum)   | 10 psig  | 10 psig                     | 10 psig                     | 10 psig                     |
| Oil Sump Capacity (quarts)   | 12   | 8                           | 12                          | 8                           |
| Crankcase Pressure <sup>①</sup> (Max.)   | 4.0 Inches H <sub>2</sub> O  | 4.0 Inches H <sub>2</sub> O | 4.0 Inches H <sub>2</sub> O | 4.0 Inches H <sub>2</sub> O |
| Magneto Drop/Spread  | 150/50   | 150/50                      | 150/50                      | 150/50                      |
| Cylinder Head Temperature with Bayonet Thermocouple (Limit)  | 460°F Max. (238°C Max.)  | 460°F Max. (238°C Max.)     | 460°F Max. (238°C Max.)     | 460°F Max. (238°C Max.)     |
| Oil Consumption  | $0.006 \times (\text{rated power of engine}) \times (\% \text{power at which measured}/100) \times (\text{hours duration}) = \text{amt. of oil consumed}$<br>1 quart of oil = 1.875 lbs<br>(Refer to the "Oil Consumption Test" in Chapter 18 of the Maintenance and Overhaul Manual (M-18)) |                             |                             |                             |
| <sup>①</sup> A sudden increase in crankcase pressure during which the liquid in the manometer fluctuates rapidly typically indicates sticking piston rings. However, before removing cylinders, investigate the breather and manometer. Refer to "Excessive Crankcase Pressure" in Chapter 8 of the Maintenance and Overhaul Manual (M-18), Troubleshooting for details. |  |                             |                             |                             |

### 7-3. Normal Operation

Information in this section supplements instructions for normal operation found in the aircraft POH. Adhere to the aircraft POH operating procedures.

#### **WARNING**

**Before flying the aircraft, be sure that all tasks listed in the section “Prerequisites for Flight” in this chapter have been completed in addition to those required by the aircraft POH and aircraft manufacturer’s instructions.**

**Operation of a malfunctioning engine can result in additional damage to the engine, bodily injury or death.**

Supplemental instructions for normal operation in this section are:

- Pre-operational Requirements
- Engine Start
- Taxi Preparation
- Engine Run-up Before Take-off
- Take-off
- Climbing/Ascent
- Cruising
- Descent
- Landing/Approach
- Engine Shutdown

#### 7-3.1. Pre-operational Requirements

1. Check the oil level, and verify quantity is with specified limits.
2. Verify oil fill cap and dipstick are secure.
3. Drain all fuel sumps and strainers in accordance with airframe manufacturer’s recommendations.
4. Check the fuel system per Pilot’s Operating Handbook (POH) and verify compliance with the section “Engine Fuel Requirements” in this chapter.
5. Check propeller and propeller hub for cracks, oil leaks, and security.
6. Check engine nacelle for signs of damage, leaks, and debris.



### 7-3.2. Engine Start

Refer to the aircraft POH for detailed engine starting procedures. Complete the “Pre-operational Requirements” in this chapter every time the engine is started. Prior to starting the engine, be sure that you are familiar with the quantity and location of the system fuel drains on the engine.

#### **WARNING**

**Do not attempt to start an engine that has been over-primed or that has become flooded. Starting an engine with a flooded intake system can result in hydraulic lock and subsequent engine malfunction or failure. Allow all fuel to drain from the intake manifold and/or cylinder prior to attempting engine starting.**

When starting the engine, ensure the battery is completely charged, especially in sub-freezing temperatures.

*CAUTION: Attempting to start your engine with a partially discharged aircraft battery may result in damage to the starter relay or possible engine kick-back resulting in a broken starter adapter clutch spring.*

Verify the tasks listed in section “Flight Prerequisites” in this chapter have been completed in addition to those required by the aircraft POH, aircraft manufacturer, or Supplemental Type Certificate (STC) holder. Note the following:

- If the engine is being started in extreme cold, it may need to be preheated. Refer to “Engine Operation in Extreme Cold” and “Engine Preheating Procedures” in this chapter.
- If the engine is started in hot weather, refer to the section “Engine Operation in Hot Weather” in this chapter for starting tips.
- If the engine is being started at high altitude, refer to the section “Ground Operation at High Density Altitude.”

#### **WARNING**

**Ensure the propeller arc is clear of personnel and obstructions before starting the engine.**

*CAUTION: If the engine is hot, engage starter first, then turn on the auxiliary fuel pump as instructed by the airframe manufacturer.*

*Release the starter as soon as the engine fires. Never engage the starter while the propeller is turning. If the starter has been engaged for 30 seconds and the engine has not started, release the starter switch and allow the starter motor to cool for three to five minutes before another starting attempt.*



*Engine operation without oil pressure will result in engine malfunction and probable failure.*

NOTE: Check oil pressure frequently. Oil pressure indication must be noted within 30 seconds in normal weather. If no pressure is observed, stop the engine and investigate the cause.

**7-3.2.1. Cold Start**

Follow the Airplane Flight Manual or Pilot’s Operating Handbook. Use the same procedure as for a normal start. After the engine begins running, it may be necessary to operate the primer (boost pump) intermittently to prevent the engine from stalling.

**7-3.2.2. Flooded Engine**

If starting attempts are prolonged, verify fuel is running out of the system drains. Do not attempt further starting until all fuel has drained out of the engine.

Hydraulic lock may be a cause of engine starting problems. Hydraulic lock is a condition where fluid accumulates in the Induction System or the cylinder assembly.

**WARNING**

**Do not operate the engine if hydraulic lock is suspected. Engine damage may occur. Perform a “Hydraulic Lock” inspection according to instructions in Chapter 7, Maintenance Inspections of TCM’s Maintenance and Overhaul Manual (M-18). If no fuel drainage is observed, discontinue starting attempts until the cause is determined. Inspect the fuel system drains for obstructions.**

**7-3.2.3. Hot Start**

Use the steps below to supplement the Airplane Flight Manual or Pilot’s Operating Handbook normal starting instructions:

NOTE: For several minutes after stopping a hot engine, heat soaked fuel injection components, (especially the fuel pump) may cause fuel vaporization resulting in restarting difficulties. To reduce difficulty, perform the following steps:

1. Fuel Selector Valve .....ON
2. Throttle.....CLOSED
3. Mixture Control: .....IDLE CUT OFF
4. Boost Pump.....ON (3-5 seconds)
5. Boost Pump.....OFF
6. Allow fuel to drain from intake prior to engine start; follow AFM/POH starting instructions.



### 7-3.3. Ground Warm-up

*CAUTION: DO NOT operate the engine at run-up speed unless the oil temperature is at least 100°F and the oil pressure is within the 30-60 psi range. Operating the engine above idle before reaching minimum oil temperature may cause a loss of oil pressure and engine damage.*

1. Maneuver aircraft nose into wind
2. Throttle.....IDLE
3. Propeller RPM .....FULL INCREASE

*CAUTION: Avoid prolonged idle at low RPM to prevent spark plug fouling.*

4. Mixture.....FULL RICH
5. Throttle.....900-1000 RPM

### 7-3.4. Taxi Preparation

Before taxi/run-up, refer to the Airplane Flight Manual or POH for detailed taxi preparation procedures applicable to your aircraft. Check the following items:

*CAUTION: DO NOT operate the engine at run-up speed unless the oil temperature is at least 100°F and the oil pressure is within the 30-60 psi range. Operating the engine above idle before reaching minimum oil temperature may cause a loss of oil pressure and engine damage.*

NOTE: For taxi operation during high ambient temperature or from fields at higher altitudes, the mixture control may require leaning for smooth engine operation. A FULL RICH mixture must be used for takeoff.

1. Maintain engine RPM between 900 and 1000 for at least one minute or until oil temperature exceeds 100°F (38°C)
2. Advance throttle slowly until tachometer indicates an engine speed of approximately 1200 RPM. Allow additional warm-up time at this speed depending on temperature. This time may be used for taxiing to takeoff position.
3. Cowling Flaps .....FULL OPEN (if equipped)
4. Mixture Control .....FULL RICH
5. Propeller Control.....MAXIMUM RPM (except for propeller governor testing)
6. Limit ground operation to time necessary to conduct warm-up and pre-flight inspection



- 7. Increase Engine RPM to 1700 (long enough to perform following checks)
  - a. Check Magnetos
    - 1) Magneto Switch .....R
    - 2) Check RPM
    - 3) Magneto Switch .....BOTH
    - 4) Check RPM
    - 5) Magneto Switch .....L
    - 6) Check RPM
  - b. The difference between magnetos individual operation should not exceed 50 RPM. Maximum drop for either magneto is 150 RPM. Observe engine smoothness during magneto switching.

**WARNING**

**Absence of RPM drop during the magneto check may be an indication of a faulty ignition circuit resulting in a condition known as “Hot Magneto.” Should the propeller be turned by hand, the engine may inadvertently start and cause personal injury or death. This condition must be corrected prior to continued aircraft operation.**

*CAUTION: Do not underestimate the importance of the pre-takeoff magneto check. When operating on single ignition, some RPM drop should be noted. Normal indications are up to 150 RPM drop and slight engine roughness as each magneto is switched off. RPM drop in excess of 150 RPM may indicate a faulty magneto or fouled spark plugs.*

- c. Minor spark plug fowling can be cleared as follows:
  - 1) Magneto Switch .....BOTH
  - 2) Throttle.....2200 RPM
  - 3) Mixture Control .....lean mixture control until RPM peaks for ten seconds. Return mixture to full rich position.

*CAUTION: Avoid prolonged single magneto operation to preclude spark plug fouling*





8. Propeller Operational Checkout

- a. Throttle.....1700 RPM
- b. Propeller Governor.....Low RPM position

Engine speed should decrease to minimum governing speed or as specified by airframe manufacturer.

- c. Propeller Governor.....High Speed Position

- 1) Observe Tachometer .....RPM drop should be 400-500 RPM
- 2) Repeats steps 8.a.- c. two to three times to cycle warm engine oil through propeller hub.

*CAUTION: Avoid prolonged low RPM, high manifold pressure operation.*

- d. If equipped,

- 1) Propeller Governor.....Feather
- 2) Observe Tachometer .....RPM drops below minimum governing RPM
- 3) Propeller Governor.....Full Increase

*CAUTION: Do not operate the engine at speeds in excess of 2000 RPM longer than necessary to complete operational tests above. Proper engine cooling depends upon forward motion of aircraft. Discontinue testing if temperature or pressure limits are approached.*

9. Instrument Checkout

Refer to Airplane Flight Manual or Pilot’s Operating Handbook for required testing

**7-3.5. Power Control**

When increasing power, enrich mixture to the full rich setting, advance RPM; then advance the throttle, in that order. When decreasing power, reduce manifold pressure with the throttle first, then adjust RPM, then adjust the mixture, in that order.



### 7-3.6. Take-Off/Climb

Supplement the Airplane Flight Manual or the POH take-off procedures with these engine settings:

1. Mixture.....FULL RICH
2. Cowl Flaps .....per POH
3. Boost pump .....per POH
4. Throttle.....Advance for rated takeoff power
5. Monitor Engine Gauges not to exceed operating limits
  - a. Manifold Pressure
  - b. Tachometer
  - c. Fuel Flow
  - d. Cylinder Head Temperature
  - e. Oil Pressure

*CAUTION: Cylinder head and oil temperatures must never be allowed to exceed limits. Near maximum temperatures should occur only when operating under adverse conditions such as high power settings, low airspeed, extreme ambient temperatures, etc. Steps should be taken to reduce such temperatures as soon as possible. If excessive temperatures are noted and cannot be explained, or if abnormal cowl flap and/or mixture settings are required to maintain temperatures, inspect to determine cause. Possible causes are broken or missing baffles, inoperative cowl flaps, sticking oil temperature control unit, or restricted fuel nozzle jets (lean fuel mixture). Faulty instruments or thermocouples may cause erroneously high (or low) indications. Refer to troubleshooting section of this manual or the maintenance and overhaul manual for troubleshooting procedures.*

### 7-3.7. Cruise Climb

For climbing or ascent procedures at full power, supplement the Airplane Flight Manual or POH with these settings.

**WARNING**

**At power settings above Maximum Cruise Power, do not use the EGT gauge as an aid to mixture adjustment. Attempts to determine “peak” EGT at high power will result in burned valves, detonation and engine failure. NO leaning is permitted above Maximum Cruise Power.**

1. Throttle.....Max. Cruise horsepower



2. Mixture Control .....FULL RICH
3. Cowl Flaps .....Set to maintain CHT/Oil Temperature
4. Immediately after takeoff, monitor engine gauges not to exceed operating limits
  - a. Manifold Pressure
  - b. Tachometer
  - c. Fuel Flow
  - d. Cylinder Head Temperature
  - e. Oil Pressure

NOTE: Maintain mixture and throttle settings until climb is complete. Upon completion of climb, reduce power settings.

NOTE: During normal climb operations above 18,000 feet, proper turbocharger operation requires minimum engine speed of 2000 RPM and manifold pressure of not less than 15 in. Hg. If lower manifold pressure operation is necessary, lean the fuel mixture to prevent an excessive rich mixture to avoid engine stoppage. If the engine experiences power loss while operating at less than 2000 RPM or 15 in. Hg. manifold pressure, see section 7-4.3.

### **7-3.8. Cruise**

Supplement the Airplane Flight Manual or POH instructions with these steps:

1. Set manifold pressure and RPM for desired cruise power settings.
2. Monitor Engine Instruments – Allow engine temperatures to stabilize (approximately 5 minutes after cruise settings).

*CAUTION: When increasing power, enrich mixture, advance RPM and adjust throttle in that order. When reducing power, retard throttle, adjust RPM and mixture, in that order.*

3. Adjust mixture to lean cruise condition using one of the cruise control adjustment methods, 7-3.8.1. Cruise Control by Performance Curve or 7-3.8.2. Cruise Control by EGT.

NOTE: During high ambient temperatures, fuel flow fluctuations, caused by vapors, may occur early in the early flight. Operating the boost pump according to the aircraft manufacturer’s recommendations will reduce the vapor in the fuel lines.

### 7-3.8.1. Cruise Control by Performance Curve

1. Adjust mixture control to lean fuel flow for cruise setting according to applicable Fuel Flow vs. Brake Horsepower performance curve (see AFM or POH).

NOTE: Minor mixture adjustments may be necessary after changing RPM.

### 7-3.8.2. Cruise Control by Exhaust Gas Temperature (EGT)

*CAUTION: Observe CHT and TIT limits (Section 2). Do not attempt to adjust mixture according to EGT above maximum cruise power setting. Engine power will change with ambient conditions. Atmospheric changes will require manifold pressure and fuel flow adjustments. Gauge fuel flow must fall between minimum and maximum values on the performance curve*

*For operation of TSIO-550G engine models above 22,000 feet, do not lean beyond 1675 °F. Refer to AFM/POH for best power settings at or below maximum cruise power setting, see model-specific altitude performance charts. Peak TIT will occur below 1675 °F at power settings below 75%.*

1. Adjust RPM and manifold pressure for desired cruise setting; No leaning is permitted above maximum cruise power setting.
2. Best Power

*CAUTION: Peak TIT and Peak EGT occur at approximately the same point, observe TIT limits during leaning operations.*

- a. Slowly move mixture control toward “lean” while observing EGT indicator. Note the position on the instrument when the needle “peaks” (further leaning reduces EGT).
  - b. At allowable cruise settings, advance mixture control toward “rich” until EGT is 100-150°F richer than peak. This will provide a best power fuel mixture at cruise.
3. Best Economy

*CAUTION: Peak TIT and Peak EGT occur at approximately the same point, observe TIT limits during leaning operations.*

- a. Slowly move mixture control toward “lean” while observing EGT indicator. Note the position on the instrument when the needle “peaks” (further leaning reduces EGT).
- b. Continue to lean mixture until EGT is 50-75°F lean of peak for best economy cruise mixture. Notable engine power change may occur during leaning, avoid engine instability due to lean misfire, indicated by engine roughness.



7-3.9. Descent

1. For descent procedures, the following steps supplement the Airplane Flight Manual or POH.
2. Descend at cruise power settings with mixture positioned for smooth engine performance.

*CAUTION: Avoid rapid descents at high RPM and idle manifold pressure.*

3. Monitor CHT and Oil temperature .....Maintain above minimum limits

NOTE: Avoid long descents at low manifold pressure. The engine can cool excessively and fail to accelerate satisfactorily when power is reapplied. If power must be reduced for long periods, adjust propeller governor for minimum RPM and set manifold pressure no lower than necessary to obtain desired performance. If outside air is extremely cold, it may be necessary to increase drag in order to maintain engine power without gaining airspeed. Do not permit cylinder temperature to drop below 300°F for periods longer than 5 minutes.

4. Manifold Pressure .....Above 18.5 in. Hg.
5. Engine Gauges .....Normal Range

7-3.10. Landing

For landing and approach procedures, refer to the Airplane Flight Manual/POH. In anticipation of a go around and subsequent need for higher power, set:

*CAUTION: Avoid rapid throttle movement to prevent manifold pressure overboost. Smooth throttle movements allow the turbochargers to keep pace with engine operating conditions.*

1. Mixture.....FULL RICH
2. Propeller.....Maximum RPM

NOTE: Advance mixture slowly toward “Full Rich.” Avoid engine roughness by leaving the mixture control leaner than Full Rich until the throttle raises manifold pressure above 15in. Hg.

3. Operate boost pump as according to the AFM/POH to maintain fuel pressure within specified limits.

**7-3.11. Engine Shutdown**

1. Supplement the AFM/POH engine shutdown procedures with the following:
2. Boost Pump.....OFF
3. Increase Engine RPM to 1700 (long enough to perform following checks)
  - a. Check Magnetos
    - 1) Magneto Switch .....R
    - 2) Check RPM
    - 3) Magneto Switch .....BOTH
    - 4) Check RPM
    - 5) Magneto Switch .....L
    - 6) Check RPM
  - b. The difference between magnetos individual operation should not exceed 50 RPM. Maximum drop for either magneto is 150 RPM. Observe engine smoothness during magneto switching.

**WARNING**

**Absence of RPM drop during the magneto check may be an indication of a faulty ignition circuit resulting in a condition known as “Hot Magneto.” Should the propeller be turned by hand, the engine may inadvertently start and cause personal injury or death. This condition must be corrected prior to continued aircraft operation.**

*CAUTION: Do not underestimate the importance of the pre-takeoff magneto check. When operating on single ignition, some RPM drop should be noted. Normal indications are up to 150 RPM drop and slight engine roughness as each magneto is switched off. RPM drop in excess of 150 RPM may indicate a faulty magneto or fouled spark plugs.*

- c. Minor spark plug fowling can be cleared as follows:
  - 1) Magneto Switch .....BOTH
  - 2) Throttle.....2200 RPM
  - 3) Mixture Control .....lean mixture control until RPM peaks for ten seconds. Return mixture to full rich position.

*CAUTION: Avoid prolonged single magneto operation to preclude spark plug fouling*



4. RPM .....Reduce to 900 RPM for five minutes.

NOTE: If RPM is raised above 1200 RPM during cool down period, reset timer to complete five minute cool-down.

5. Idle at 900 RPM for five minutes to cool turbochargers
6. Mixture.....IDLE CUTOFF  
Wait for propeller rotation to stop
7. Magneto Switch .....OFF

**WARNING**

**Do not turn the propeller while the Magneto Switch is the BOTH, LEFT or RIGHT positions. Do not turn the propeller on a hot engine even if the Magneto Switch is in the OFF position. The engine could kick back as a result of auto-ignition caused by a small amount of fuel remaining in the cylinders. Auto-ignition could restart the engine and cause serious bodily injury or death.**

## 7-4. Emergency Operation

Information in this section supplements instructions for emergency operations found in the aircraft POH. Perform the following engine-specific steps in addition to the POH requirements when responding to emergency conditions.

If a malfunction should occur in-flight, certain remedial actions may eliminate or reduce the severity of the condition. Some malfunctions which might occur are listed in this chapter. Recommended corrective action is also included. However, no single procedure will be applicable in every situation.

Thorough aircraft and engine familiarity are invaluable assets in assessing a given situation and responding accordingly.

### **WARNING**

**Control of the aircraft must be maintained at all times. Do not stall the airplane attempting to extend the gliding distance.**

The following terms are used throughout these emergency operation procedures:

|                            |  |
|----------------------------|--|
| Land as Soon as Practical: | Land at the nearest airport suitable for the aircraft.   |
| Land as Soon as Possible:  | Land at the best available landing area within gliding distance of the aircraft, following the airframe manufacturer's procedures in the Airplane Flight Manual (AFM). |

### 7-4.1. Engine Fire during Start

1. Follow AFM/POH recommendations

### **WARNING**

**Maintain aircraft control at all times. Do not stall the airplane attempting to extend the gliding distance.**

### 7-4.2. Engine Roughness

1. Follow AFM/POH Recommendations

### **WARNING**

**If roughness is severe or the cause cannot be determined, engine failure may be imminent. Follow the AFM/POH emergency procedures**





### 7-4.3. Turbocharger Failure

A failed turbocharger results in the inability of a turbocharged engine to develop manifold pressure above ambient pressure, reverting to a “normally aspirated” engine. Continued operation is possible, but at reduced horsepower. If turbocharger failure occurs before takeoff, do not attempt to fly. If failure occurs in flight:

**WARNING**

**If the turbocharger failure is caused by burned through exhaust, a serious fire hazard exists. Follow the AFM/POH engine failure instructions. If turbocharger failure occurs before flight, DO NOT attempt flight. If failure occurs in flight, land as soon as practical.**

1. Engine continues running after turbocharger failure:
  - a. Adjust mixture for appropriate Manifold Air Pressure and RPM.
  - b. Land as soon as practical.

NOTE: At altitudes above 18,000 feet and over-rich mixture may result if the turbocharger fails, causing the engine to stop firing.

2. Turbocharger failure causes over-rich mixture and engine stops firing:
  - a. Mixture Control .....IDLE CUTOFF
  - b. Throttle.....Desired cruise manifold pressure
  - c. Propeller Control.....Normal Cruise RPM
  - d. Mixture.....Advance slowly
  - e. When the proper mixture is reached, the engine will start. Continue to adjust the mixture control until the correct fuel flow for the manifold pressure and RPM is reached.

NOTE: An interruption in fuel flow or manifold pressure will result in turbocharger “rundown.” At high altitude, restoring fuel flow alone will not restart the engine. If momentary power loss is followed by surging RPM, fuel flow and manifold air pressure, the turbocharger operation may be restored by following section 7-4.3., step 3.



3. Momentary turbocharger failure caused by loss of fuel flow or manifold pressure:
  - a. Mixture Control .....IDLE CUTOFF
  - b. Fuel Selector .....Position to allow use of boost pump
  - c. Boost Pump.....ON
  - d. Throttle.....Normal Cruise Position
  - e. Propeller Control.....Adjust for normal cruise RPM
  - f. Mixture.....Advance slowly
  - g. NOTE: A surge of power will accompany engine restart. Adjust mixture control after manifold pressure return to normal.
  - h. Boost Pump.....Set according to AFM/POH
  - i. Mixture Control .....Adjust to desired setting
  - j. If engine fails to restart, descend below 18,000 feet and repeat.

**7-4.4. High Cylinder Head Temperature**

Supplement AFM/POH with these steps:

1. Cowl Flaps .....OPEN
2. Mixture.....Full Rich
3. Airspeed .....Increase

If temperature cannot be maintained within limits, reduce power, land as soon as possible and have the malfunction evaluated prior to further flight.

**7-4.5. High Oil Temperature**

NOTE: Prolonged high oil temperature indications are usually accompanied by a reduction in oil pressure. If oil pressure remains normal, a high temperature indication may be caused by a faulty gauge or thermocouple. If oil temperature drops as temperature increases, proceed as follows:

1. Cowl Flaps .....OPEN
2. Airspeed .....Increase
3. Power .....Reduce if steps 1 and 2  
do not lower temperature
4. LAND AS SOON AS PRACTICAL

*CAUTION: If these steps do not restore oil pressure to normal, an engine failure or severe damage is imminent. Follow the AFM/POH emergency instructions. LAND AS SOON AS POSSIBLE.*



### 7-4.6. Low Oil Pressure

**WARNING**

If oil pressure drops below 30 psi, an engine failure is imminent. Follow AFM/POH emergency procedures.

If the oil pressure drops suddenly from a normal indication of 30-60 psi, monitor temperature closely, land as soon as possible and have the engine inspected prior to further flight.

### 7-4.7. In-Flight Restart

1. Follow AFM/POH

*CAUTION: Do not shutdown an engine for practice or training purposes. Whenever engine failure is simulated, do so by reducing power.*

*CAUTION: A few minutes to exposure to temperatures and airspeed at flight altitudes can have the same effect on an inoperative engine as hours of cold-soak in sub-arctic conditions. If the engine must be restarted, consider descending to warmer air. Closely monitor for excessive oil pressure as the propeller is unfeathered. Allow the engine to warm at minimum RPM before continued flight operations.*

### 7-4.8. Engine Fire In-Flight

1. Fuel Selector .....OFF
2. Mixture.....IDLE CUTOFF
3. Throttle.....CLOSED
4. Propeller Control
  - a. Feathering Type .....FEATHER
  - b. Non-Feathering Type .....FULL DECREASE RPM
5. Magneto Switch .....OFF
6. Execute AFM/POH EMERGENCY/FORCED LANDING PROCEDURES and LAND AS SOON AS POSSIBLE

## 7-5. Engine Operation in Abnormal Environments

The anticipated types of abnormal environments are:

- Extreme cold weather
- Extreme hot weather
- High density altitude ground operation

### 7-5.1. Engine Operation in Extreme Cold

Engine starting during extreme cold weather is generally more difficult. Cold soaking causes the oil to become thicker (more viscous), making it difficult for the starter to crank the engine which results in slow cranking speeds and an abnormal drain on the battery capacity. At low temperatures, aviation gasoline does not vaporize readily, further complicating the starting procedure.

#### **WARNING**

**Over priming can cause a flooded intake resulting in a "hydraulic lock" event and subsequent engine malfunction or failure. If you over prime, or flood your engine, make certain that all fuel has drained from the intake manifold and/or cylinder prior to attempting engine starting.**

*CAUTION: Always use an external power source when attempting to start aircraft engine in cold weather.*

False starting (failure to continue running after starting) often results in condensation on spark plug electrodes. This moisture can freeze and must be eliminated either by preheating the engine or removing and cleaning the spark plugs.

Engine preheating and an auxiliary power unit (APU) are required to facilitate engine starting during cold weather and when the engine has been exposed to temperatures below 20°F (-7°C) for more than 2 hours. Refer to the "Engine Preheating Procedures" in this chapter and the aircraft POH or Airplane Flight Manual for specific instructions. At ambient temperature between 20 to 40°F (-7 to 4°C), refer to "Cold Weather Starting Without Preheating" in this chapter.

#### **WARNING**

**Failure to properly preheat a cold-soaked engine may result in oil congealing within the engine, oil hoses, and oil cooler with subsequent loss of oil flow, possible internal damage to the engine, and subsequent engine failure.**

#### **WARNING**

**Superficial application of preheat to a cold soaked engine can cause damage to the engine. An inadequate application of preheat may warm the engine enough to permit starting but will not decongeal oil in the sump, lines, cooler, filter, etc.**



**Congeaed oil in these areas require considerable preheat. The engine may start and appear to run satisfactorily, but can be damaged from lack of lubrication due to the congealed oil blocking proper oil flow through the engine. The amount of damage will vary and may not become evident for many hours. However, the engine may be severely damaged and may fail shortly after application of high power.**

Prior to operation and/or storage in cold weather, ensure the engine is serviced with the correct viscosity oil for the ambient temperature.

In the event of temporary cold weather operation, store the aircraft in a heated hangar between flights. Service the oil sump as required with the specified oil grade as specified in “Engine Oil Servicing” in Chapter 5 of this manual.

*CAUTION: Attempting to start an engine with a partially discharged aircraft battery may result in damage to the starter relay or possible engine kick-back resulting in a broken starter adapter clutch spring.*

## 7-5.2. Engine Preheating

*CAUTION: Proper engine preheating procedures require thorough application of preheat to all parts of the engine. Hot air must be applied directly to the oil sump and external oil lines as well as the cylinders, air intake, and oil cooler. Because excessively hot air can damage non-metallic components such as seals, hoses, and drive belts, do not attempt to hasten the preheat process.*

The preferred method of preheating is to place the aircraft in a heated hangar for a minimum of 4 hours prior to flight. Optional preheating methods are:

- A high volume combustion heater with ducts directed to the engine oil sump, cylinders, and oil cooler. Refer to the section “Engine Preheat with a Combustion Heater” in this chapter.

**OR**

- An engine-mounted preheating system. Refer to “Engine Preheat with an Engine-Mounted Preheater” in this chapter.

### 7-5.2.1. Engine Preheat with a Combustion Heater

If a heated hangar is not available and the aircraft and engine have been exposed to temperatures below 20°F (-7°C) for two hours or more, without an engine mounted preheating system, use the following method:

1. Select a high-volume hot air heater.

**NOTE:** Small electric heaters inserted in the cowling opening do not appreciably warm the oil and may result in superficial preheating.

2. Preheat all engine parts. Apply preheated air directly to these listed parts for at least 30 minutes:
  - a. Oil sump
  - b. Oil filter
  - c. External oil lines
  - d. Oil cooler
  - e. Coolant radiator (if equipped)
  - f. Cylinder assemblies
  - g. Air intake
3. Periodically feel the top of the engine for warmth. Apply heat directly to the induction tubes and cylinders will promote vaporization and ease starting. Alternately heat the sump and engine cylinders until engine start.
4. Start the engine immediately after completion of the preheating process. Since the engine will be warm, use the normal start procedure per instructions in the section “Engine Start” in this chapter.

*CAUTION: If oil pressure is not indicated within 30 seconds, shut down the engine and determine the cause. Operating the engine without oil pressure may result in engine malfunction or stoppage.*

*CAUTION: Do not close the cowl flaps in an attempt to hasten engine warm-up.*

5. Operate the engine at 1000 RPM until some oil temperature is indicated.
  - a. Monitor the oil pressure closely. If necessary, retard the throttle to maintain oil pressure below 100 psi. If oil pressure is less than 30 psi, or cannot be maintained below 100 psi, shut the engine down and repeat the preheat process. Do not close the cowl flaps to facilitate engine warm-up.
  - b. Monitor the oil temperature until it reaches at least 100°F (38°C).

*CAUTION: Do not operate the engine at speeds above 1700 RPM unless the oil temperature is at least 100°F (38°C) and the oil pressure is between 30 to 60 psi.*



6. Run the engine up to 1700 RPM; in 100 RPM increments to prevent oil pressure from exceeding 100 psi.

**WARNING**

**Operating the engine above 1700 RPM before reaching the minimum oil temperature may result in engine malfunction, engine failure, injury or death.**

7. At 1700 RPM, adjust the propeller control to FULL DECREASE RPM until minimum governing RPM is observed; return the control to FULL INCREASE RPM. Repeat this procedure three or four times to circulate warm oil into the propeller dome.
8. If the aircraft manufacturer recommends checking the propeller feathering system, move the control to the FEATHER position. Do not allow the RPM to drop more than 300 RPM below minimum governing speed.

*CAUTION: Continually monitor oil pressure during run up.*

9. When oil temperature has reached 100°F (38°C) and oil pressure does not exceed 60 psi at 2500 RPM, the engine has been warmed sufficiently to accept full rated power.

### 7-5.2.2. Engine Preheat with an Engine-Mounted Preheater

**WARNING**

**Do not leave an engine-mounted pre-heater system on for more than 24 hours prior to flight. Continuous operation of engine-mounted preheater systems may result in aggressive internal engine corrosion.**

If a heated hangar is not available and the aircraft and engine have been exposed to temperatures below 20°F (-7°C) for 2 hours or more and has an engine-mounted preheating system the following procedure may be used.

Engine mounted preheating systems should include individual cylinder head heater thermocouples, oil sump heater pad and crankcase heater pad. The use of a nacelle blanket will increase the effectiveness of engine preheating.

1. Follow the preheating system's manufacturer's installation and operation instructions.
2. Begin preheating of the engine at least 5 hours prior to expected departure. Do not operate an engine preheating system continuously for more than 24 hours.

NOTE: The use of an approved thermal blanket or cover will help reduce the effects of wind and cold air circulation when the aircraft is not stored in a hangar. The preheating system manufacturer should have thermal blankets available.

3. Start the engine immediately after completion of the preheating process. Use the normal start procedure in the "Engine Start" section of this chapter.



*CAUTION: If oil pressure is not indicated within 30 seconds, shut down the engine and determine the cause. Operating the engine without oil pressure may result in engine malfunction or stoppage.*

*Do not close the cowl flaps in an attempt to hasten engine warm-up.*

4. Operate the engine at 1000 RPM until some oil temperature is indicated.
  - a. Monitor the oil pressure closely. If necessary, retard the throttle to maintain oil pressure below 100 psi. If oil pressure is less than 30 psi, or cannot be maintained below 100 psi, shut the engine down and repeat the preheat process. Do not close the cowl flaps to facilitate engine warm-up.
  - b. Monitor the oil temperature until it reaches at least 100°F (38°C).

*CAUTION: Do not operate the engine at speeds above 1700 RPM unless the oil temperature is at least 100°F (38°C) and the oil pressure is between 30 to 60 psi.*

5. Run the engine up to 1700 RPM; approach this RPM in increments to prevent oil pressure from exceeding 100 psi.

**WARNING**

**Operating the engine above 1700 RPM before reaching the minimum oil temperature may result in engine malfunction, engine failure, injury or death.**

6. At 1700 RPM, adjust the propeller control to FULL DECREASE RPM until minimum governing RPM is observed; return the control to FULL INCREASE RPM. Repeat this procedure three or four times to circulate warm oil into the propeller dome.
7. If the aircraft manufacturer recommends checking the propeller feathering system, move the control to the FEATHER position but do not allow the RPM to drop more than 300 RPM below minimum governing speed.

*CAUTION: Continually monitor oil pressure during run up.*

8. When oil temperature has reached 100°F (38°C) and oil pressure does not exceed 60 psi at 2500 RPM, the engine has been warmed sufficiently to accept full rated power.





### 7-5.2.3. Cold Weather Starting Without Preheating

At ambient temperature between 20 to 40°F (-7 to 4°C), the following procedure is recommended:

*CAUTION: Attempting to start your engine with a partially discharged aircraft battery may result in damage to the starter relay or possible engine kickback, resulting in a broken starter adapter clutch spring.*

1. Use an external power source or ensure the aircraft battery is fully charged.
2. Use the normal start procedure in the “Engine Start” section of this chapter and the aircraft AFM/POH. Do not over prime the engine.

#### **WARNING**

**Overpriming can cause a flooded intake resulting in a "hydraulic lock" event and subsequent engine malfunction or failure. If you over prime, or flood your engine, make certain that all fuel has drained from the intake manifold and/or cylinder prior to attempting engine starting.**

*CAUTION: If oil pressure is not indicated within 30 seconds, shut down the engine and determine the cause. Operating the engine without oil pressure may result in engine malfunction or stoppage.*

*Do not close the cowl flaps in an attempt to hasten engine warm-up.*

3. Operate the engine at 1000 RPM until some oil temperature is indicated.
4. Monitor the oil pressure closely. If necessary, retard the throttle to maintain oil pressure below 100 psi. If oil pressure is less than 30 psi, or cannot be maintained below 100 psi, shut the engine down and follow the preheat instructions to prevent engine damage. Do not close the cowl flaps to facilitate engine warm-up.
5. Check the oil temperature; it should be at least 100°F (38°C).

*CAUTION: In the next step, do not operate the engine at speeds above 1700 RPM unless the oil temperature is at least 100°F (38°C) and the oil pressure is between 30 to 60 psig.*

6. Run the engine up to 1700 RPM; approach this RPM in increments to prevent oil pressure from exceeding 100 psi.

#### **WARNING**

**Operating the engine above 1700 RPM before reaching the minimum oil temperature may result in engine malfunction, engine failure, injury or death.**



7. At 1700 RPM, adjust the propeller control to FULL DECREASE RPM until minimum governing RPM is observed; return the control to FULL INCREASE RPM. Repeat this procedure three or four times to circulate warm oil into the propeller dome.
8. If the aircraft manufacturer recommends checking the propeller feathering system, move the control to the FEATHER position but do not allow the RPM to drop more than 300 RPM below minimum governing speed.

*CAUTION: Continually monitor oil pressure during run up.*

9. When oil temperature has reached 100°F (38°C) and oil pressure does not exceed 60 psi at 2500 RPM, the engine has been warmed sufficiently to accept full rated power.



### 7-5.3. Engine Operation in Hot Weather

“Hot weather” is defined as ambient temperature in excess of 90°F (32°C).

After an engine is shutdown, the temperature of various components will begin to stabilize. The hotter parts such as cylinders and oil will cool, while other parts will begin to heat up due to lack of air flow or heat convection from those engine parts that are cooling. At some point following engine shutdown, the entire unit will stabilize near the ambient temperature. This time period will be determined by temperature and wind conditions and may take several hours.

Heat soaking occurs between 30 minutes to one hour following shutdown. During this time, the fuel system will warm causing the fuel in the pump and fuel lines to “boil” or vaporize. During subsequent starting attempts, the fuel pump will initially be pumping a combination of fuel and fuel vapor. At the same time, the injection nozzle lines will be filled with varying amounts of fuel and vapor. Until the entire fuel system becomes filled with liquid fuel, difficult starting and unstable engine operation can be expected.

Three hot weather operation situations requiring special instructions are:

- Starting a hot engine (Section 7-3.2.3)
- Ground operation under high ambient temperature conditions (Section 7-5.3.3)
- Take-off and initial climb out under high ambient conditions (Section 7-5.3.4)

Prior to operating the engine in hot weather, ensure the engine is serviced with the correct viscosity oil specified in “Oil Specifications” in Chapter 2, Engine Specifications and Operating Limits. In the event of temporary cold weather exposure, store the aircraft in a hangar between flights. Service the oil sump as required with the specified oil grade as specified in the section “Engine Oil Servicing” in Chapter 5.

#### **Operating Tips**

- Inspect the air filter frequently for contamination; be prepared to clean or replace it, if necessary.
- If the aircraft is flown in dusty conditions, TCM recommends more frequent oil changes.
- Use dust covers over openings in the cowling for additional protection.



**7-5.3.1. Cooling an Engine in Hot Weather**

- Reduce ground operation to a minimum to keep engine temperatures down.
- Open cowl flaps fully while taxiing.
- Park the aircraft so as to face into the wind to take advantage of the cooling effect.

**7-5.3.2. Engine Restart in Hot Weather**

Restarting attempts will be the most difficult from 30 minutes to 1 hour after shutdown. Following that interval, fuel vapor will decrease and present less of a restart problem.

**7-5.3.3. Ground Operation in Hot Weather**

- Monitor oil and cylinder temperatures closely during taxiing and engine run up.
- Operate with cowl flaps full open.
- Do not operate the engine at high RPM except for necessary operational checks.
- If take-off is not to be made immediately following engine run-up, face the aircraft into the wind with the engine idling at 900-1000 RPM.

1. Fuel selector .....ON
2. Throttle.....CLOSED
3. Mixture Control .....IDLE/CUTOFF
4. Boost pumps .....ON (3-5 seconds)
5. Boost pumps .....OFF

**WARNING**

**Allow all fuel to drain from the intake system prior to starting the engine.**

Refer to the Airplane Flight Manual or Pilot’s Operating Handbook (AFM) for normal engine starting procedures.

**7-5.3.4. Take-off and Initial Climb Out in Hot Weather**

1. Mixture control .....FULL RICH

NOTE: Under extreme conditions, it may be necessary to manually lean the mixture to sustain engine operation at low RPM.

2. Do not operate the engine at maximum power longer than necessary to establish the climb configuration recommended by the aircraft manufacturer.
3. Monitor temperatures closely.
4. Maintain sufficient airspeed and attitude to provide engine cooling.
5. Cowl flaps .....FULLY OPEN (if equipped)



#### **7-5.4. Ground Operation at a High Density Altitude**

*CAUTION: Reduced engine power will result from higher density altitude associated with high temperature.*

Idle fuel mixture may be rich during high density altitude conditions. Lean the fuel mixture to sustain operation at low RPM. When practical, operate the engine at higher idle speed.

NOTE: A FULL RICH mixture is required during takeoff.

If higher than desired temperatures are experienced during the climb phase, establish a lower angle of attack or higher climb speed, consistent with safe operating practices to provide increased engine cooling.



### 7-6. Troubleshooting

#### 7-6.1. General

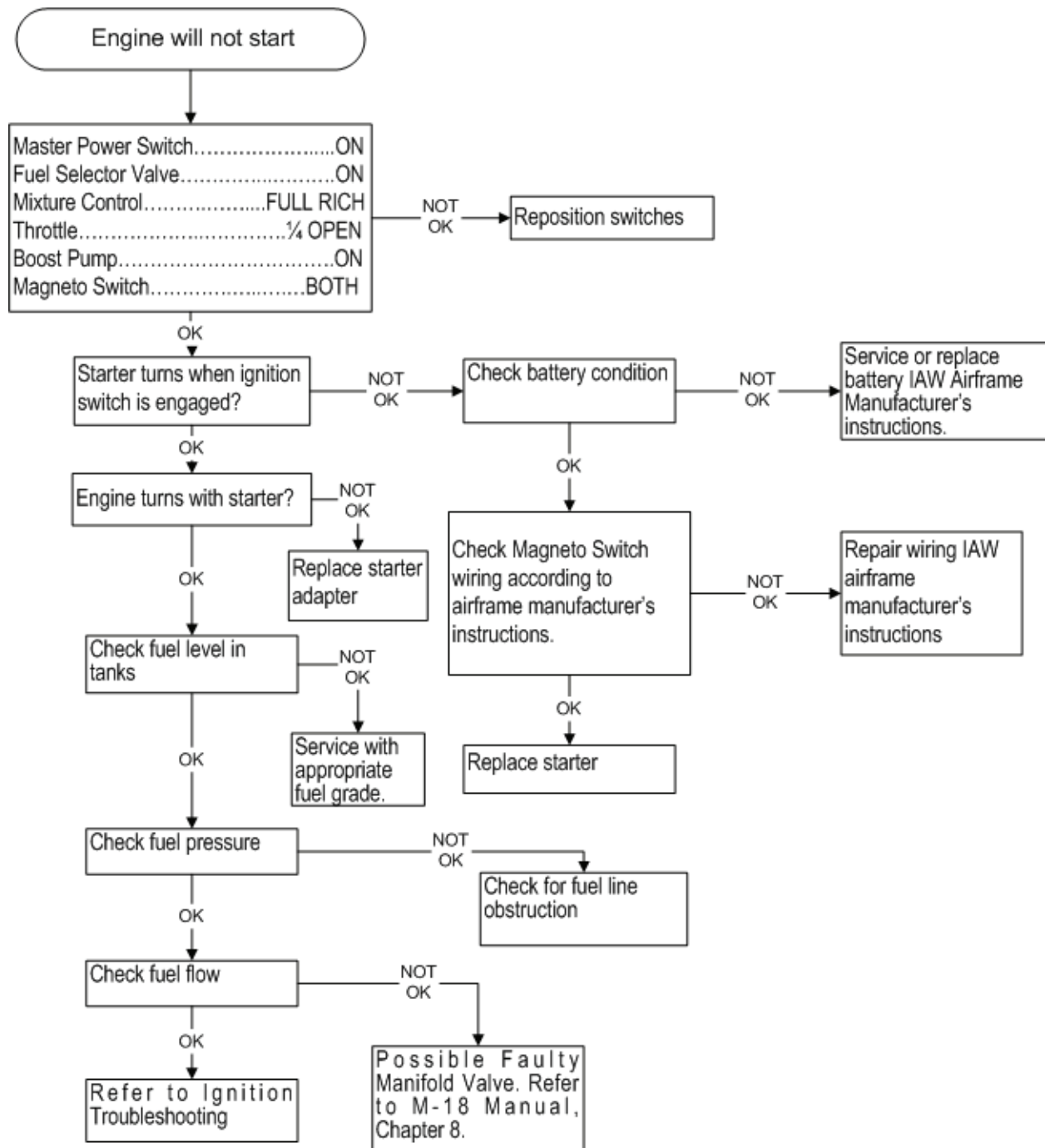

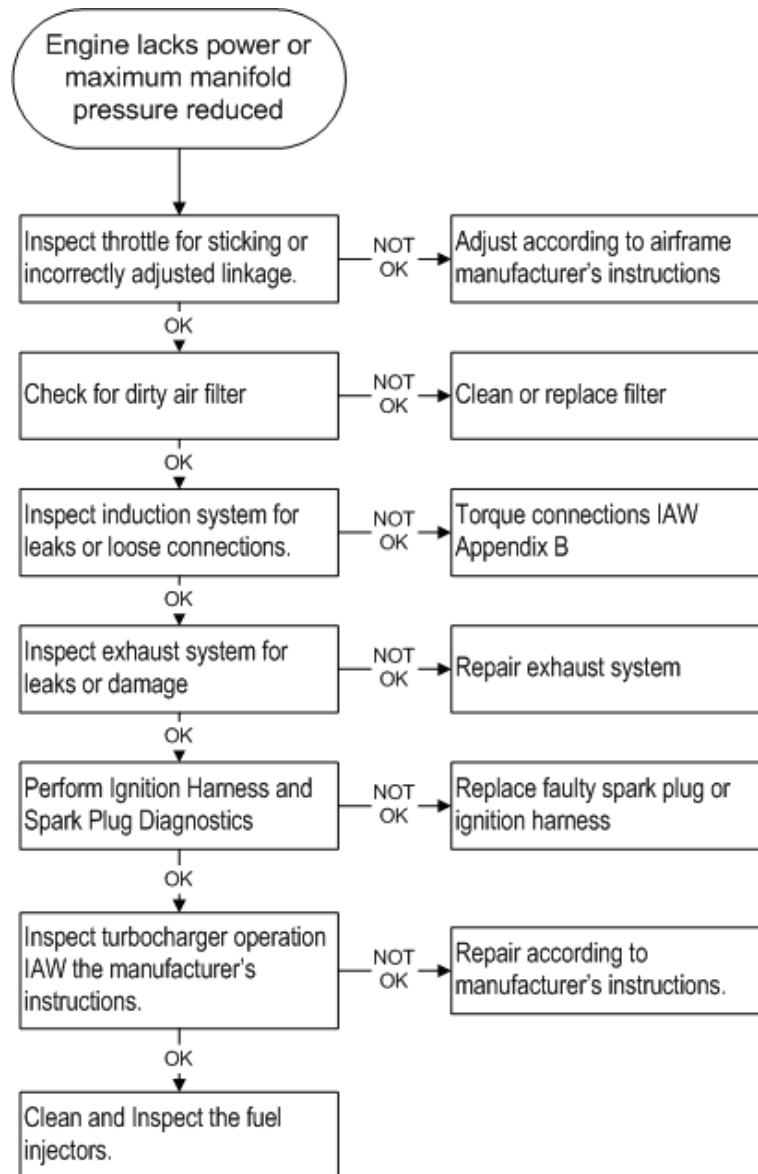
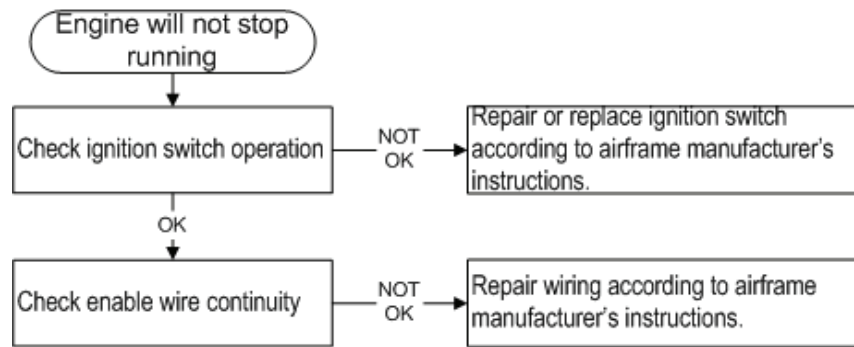



### 7-6.2. Lubrication System

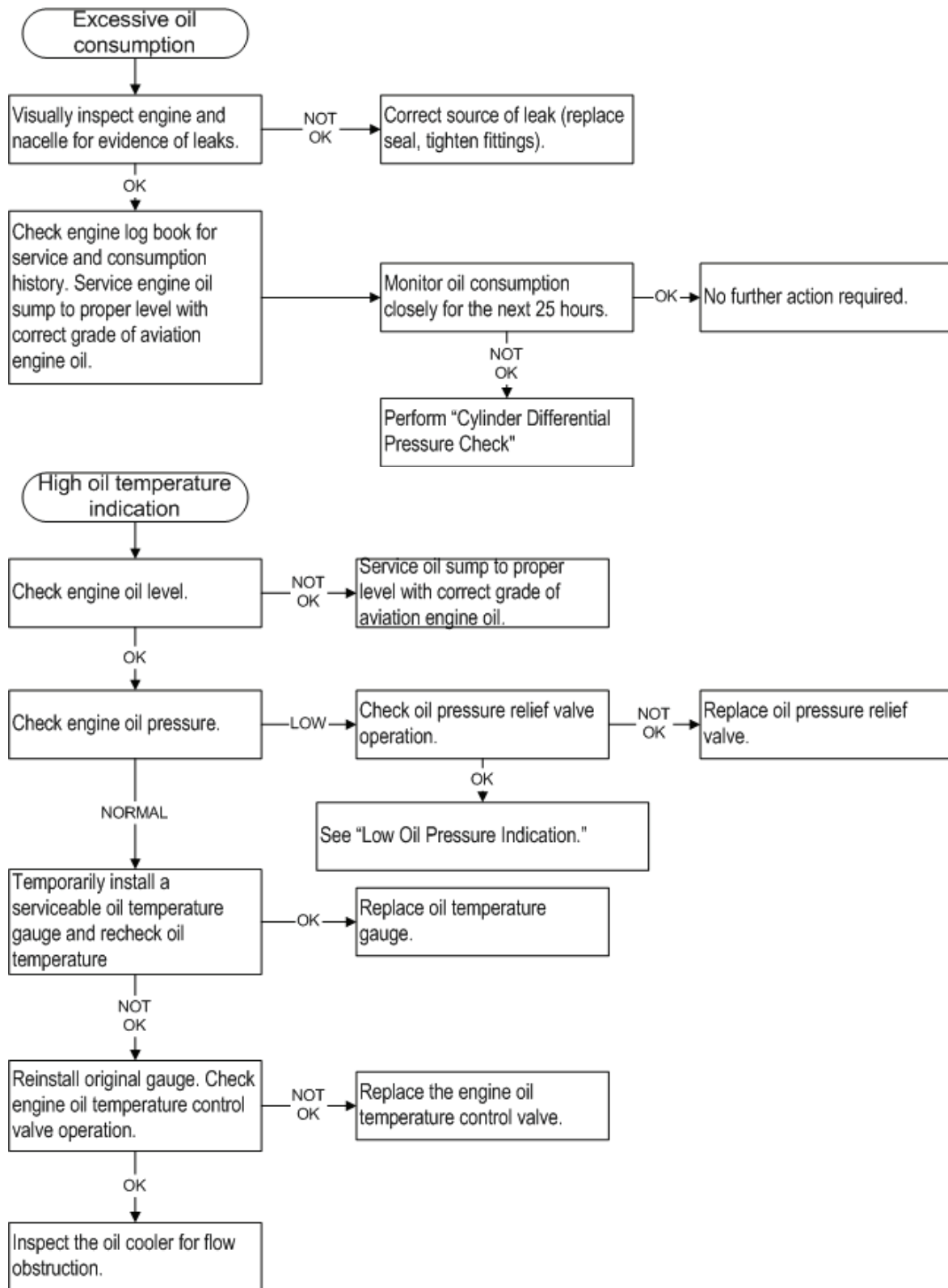



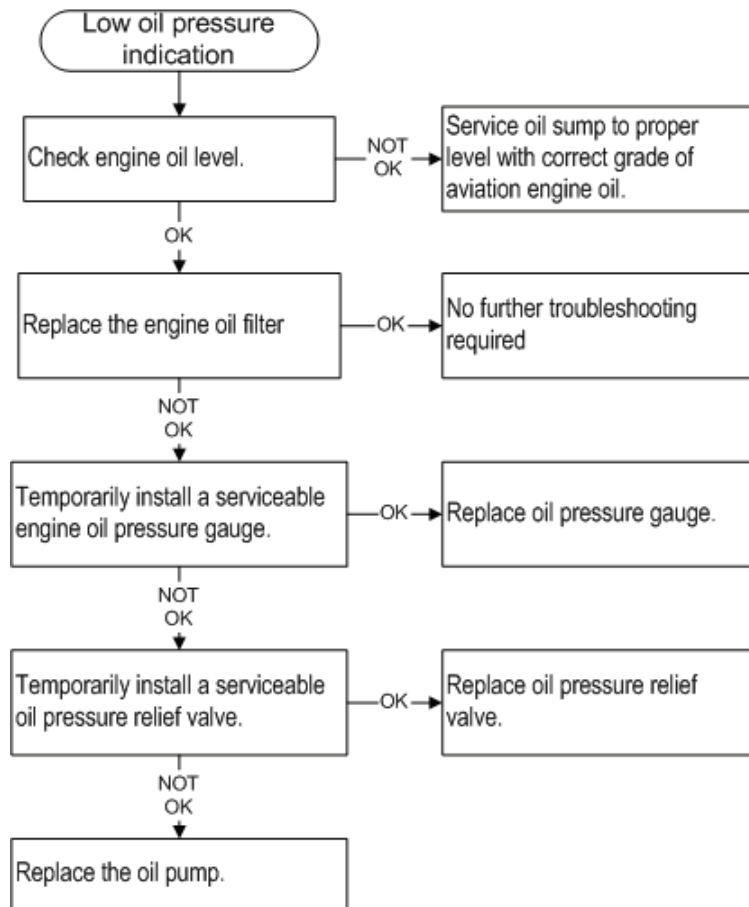



### 7-6.3. Ignition Harness and Spark Plug Diagnostics

